

**CARSON CITY CONSOLIDATED MUNICIPALITY  
NOTICE OF MEETING OF THE  
BOARD OF SUPERVISORS AND BOARD OF HEALTH**

**Day:** Thursday  
**Date:** March 2, 2023  
**Time:** Beginning at 8:30 am  
**Location:** Community Center, Robert ‘Bob’ Crowell Board Room  
851 East William Street  
Carson City, Nevada

**AGENDA**

**NOTICE TO THE PUBLIC:**

Members of the public who wish to view the meeting may watch the livestream of the Board of Supervisors meeting at [www.carson.org/granicus](http://www.carson.org/granicus) and by clicking on “In progress” next to the meeting date, or by tuning in to cable channel 191. Livestream of the meeting is provided solely as a courtesy and convenience to the public. Carson City does not give any assurance or guarantee that the livestream or cable channel access will be reliable. Although all reasonable efforts will be made to provide livestream, unanticipated technical difficulties beyond the control of City staff may delay, interrupt, or render unavailable continuous livestream capability.

The public may provide public comment in advance of a meeting by written submission to the following email address: [publiccomment@carson.org](mailto:publiccomment@carson.org). For inclusion or reference in the minutes of the meeting, your public comment must include your full name and be submitted via email by not later than 3:00 p.m. the day before the meeting. Public comment during a meeting is limited to three minutes for each speaker.

- 1. Call to Order - Board of Supervisors**
  
- 2. Roll Call**
  
- 3. Invocation - Pastor Gavin Jarvis, Living Stones Church**
  
- 4. Pledge of Allegiance**
  
- 5. Public Comment:\*\***

The public is invited at this time to comment on and discuss any topic that is relevant to, or within the authority of this public body.

**6. For Possible Action: Approval of Minutes -**

6.A February 2, 2023

[02-02-2023 Minutes \(BOS\).pdf](#)

**Consent Agenda**

-----  
-----  
All matters listed under the consent agenda are considered routine and may be acted upon by the Board of Supervisors with one action and without an extensive hearing. Any member of the Board may request that an item be taken from the consent agenda, discussed and acted upon separately during this meeting. The Mayor, or the Mayor Pro-Tem, retains discretion in deciding whether or not an item will be pulled off the consent agenda.  
-----  
-----

**7. Finance**

7.A For Possible Action: Discussion and possible action regarding the report on the condition of each fund in the treasury and the statements of receipts and expenditures through February 17, 2023, per NRS 251.030 and NRS 354.290. (Sheri Russell-Benabou, srussell@carson.org)

Staff Summary: NRS 251.030 requires the Chief Financial Officer (for the purpose of the statute acting as the County Auditor) to report to the Board of Supervisors, at each regular meeting thereof, the condition of each fund in the treasury. NRS 354.290 requires the County Auditor to report to the Board of Supervisors a statement of revenues and expenditures based on the accounts and funds as were used in the budget. A more detailed accounting is available on the City’s website – [www.carson.org](http://www.carson.org).

[BOS Cash Report 02-17-2023.pdf](#)

**8. Purchasing and Contracts**

8.A For Possible Action: Discussion and possible action regarding a proposed increase in purchase authority in the amount of \$5,386.82 to PO 23200198, beyond the previously approved amount of \$127,529, resulting in a new not to exceed amount of \$132,915.82 to purchase a Toro Groundskeeper 5900 for the Carson City Parks, Recreation and Open Space Department (“Parks Department”) from Turfstar Western, utilizing a cooperative purchasing agreement through Omnia Partners Public Sector (“OMNIA”). (Carol Akers, Cakers@carson.org and David Navarro, DNavarro@carson.org)

Staff Summary: The increase in purchase authority is being requested due to additional fees for setup and delivery not included in the original quote.

[Turf Star Updated Quote with Delivery & Set up.pdf](#)

[staff report #12B 08-18-22.pdf](#)

[Turf Star Original Quote.pdf](#)

8.B For Possible Action: Discussion and possible action regarding a proposed increase in purchase authority in the amount of \$7,061.62, beyond the previously approved amount of \$80,226.48, resulting in a new not to exceed amount of \$87,288.10, to purchase various kitchen appliances for the Carson City Sheriff's Office Jail ("Jail") utilizing joinder contract (#R180202) between Region 4 Education Service Center, Houston, Texas and National Restaurant Supply. (Carol Akers, cakers@carson.org and Sheriff Ken Furlong, kfurlong@carson.org)

Staff Summary: The increase in purchase authority is being requested as the result of changing the Jail convection steamer from a gas to electric appliance.

[National Restaurant Supply\\_UPDATED\\_Quote.pdf](#)

[13A.pdf](#)

[National Restataurant Supply\\_Original Quote.pdf](#)

8.C For Possible Action: Discussion and possible action regarding Contract No. 23300294 with Mission Critical Partners to provide consulting services for replacing the Tiburon Computer Aided Dispatch System, Records Management System and Jail Management System ("CAD/RMS/JMS") for a not to exceed amount of \$165,191, to be funded by the 911 Surcharge Fund. (Carol Akers, cakers@carson.org and Undersheriff Jerome Tushbant, jtushbant@carson.org)

Staff Summary: Carson City has used Mission Critical Partners for several CAD projects. With funding approved by the 911 Surcharge Advisory Committee, this consultant may provide services including product selection, procurement, cutover and interoperability for the new CAD/RMS/JMS system.

[23300294 DRAFT Contract.pdf](#)

8.D For Possible Action: Discussion and possible action regarding a determination that ACCO Engineered Systems, Inc. ("ACCO") is the lowest responsive and responsible bidder pursuant to Nevada Revised Statutes ("NRS") Chapter 338, and whether to award Contract No. 23300231 for the Juvenile Courts Multi-Zone HVAC Unit Replacement Project ("Project") to ACCO for a total amount not to exceed \$317,753.70. (Carol Akers, cakers@carson.org and Randall Rice, rrice@carson.org)

Staff Summary: The Project consists of replacing one multi-zone HVAC unit located on the southern section of the roof of the Juvenile Courts building. The not to exceed amount of \$317,753.70 comprises the base bid amount of \$288,867, plus a 10% contingency of \$28,886.70. The engineer's base bid estimate was \$290,000. The Project was approved as part of the Fiscal Year ("FY") 2023 Capital Improvement Plan ("CIP").

[23300231 Bid Tabulation\\_ROA.pdf](#)

**(End of Consent Agenda)**

**Ordinances, Resolutions, and Other Items**

**9. Item(s) pulled from the Consent Agenda will be heard at this time.**

**10. Juvenile**

10.A For Possible Action: Discussion and possible action regarding the proposed acceptance of Partnership Carson City's ("PCC") Comprehensive Opioid, Simulant, and Substance Abuse Program ("COSSAP") subgrant funds in the amount of \$90,000, effective January 1, 2023 through August 14, 2023, to be used for an additional full time employee ("FTE") and related expenses, such as training and travel, for a Juvenile Outreach Specialist, and the proposed acceptance of two additional subgrants if they are awarded, each for the same amount per year and for the same purpose through August 14, 2025, for a total award of \$270,000. (Ali Banister, [abanister@carson.org](mailto:abanister@carson.org))

Staff Summary: PCC has received a COSSAP Grant and has offered to supply \$90,000 per year of their grant funds to reimburse Carson City for three years to fund a Juvenile Outreach Specialist FTE and related expenses to assist the Carson City Juvenile Detention/Probation Department of the First Judicial District Court ("Juvenile Services") to bring a more cohesive solution to assist the community with services for at-risk juveniles. While PCC has stated that it will provide this grant to Juvenile Services for three years, only the first year is before the Board of Supervisors ("Board") for immediate approval because PCC receives a COSSAP grant one year at a time. However, this agenda item also requests advance authorization for acceptance of the grant funds for the next two years if they are awarded.

[PCC Whole Grant Award Ltr.pdf](#)

[COSSAP NOSA unsigned.pdf](#)

[PCC Award Ltr.pdf](#)

[PCC COSSAP Terms and Conditions.pdf](#)

**11. District Attorney**

11.A For Possible Action: Discussion and possible action regarding a proposed settlement of claims by the State of Nevada and its political subdivisions, including Carson City, against Walmart Inc. concerning opioid-related claims and the execution of a proposed "Subdivision Participation Form" to be included in the written settlement agreement which will result in Carson City receiving approximately \$328,343.01 in accordance with the terms of the settlement agreement and the One



Nevada Agreement previously agreed upon among the State of Nevada and participating political subdivisions. (Jason D. Woodbury, [jwoodbury@carson.org](mailto:jwoodbury@carson.org))

Staff Summary: The State of Nevada and the law firm of Eglet Adams have negotiated terms of a proposed settlement with Walmart to resolve opioid-related claims by the State of Nevada and its political subdivisions which are parties to the One Nevada Agreement. Under the terms of the proposed settlement agreement, Carson City would agree to release and forever discharge its "Released Claims," as defined in the settlement agreement, in exchange for Walmart's payment of \$32,231,037.17 to the State of Nevada to be allocated among the State and participating political subdivisions in accordance with the terms of the One Nevada Agreement. Carson City's net allocation of the Walmart settlement funds is presently estimated to be \$328,343.01. Staff recommends approval of the proposed settlement.

[Walmart Settlement Agreement \(2022.12.02\)\\_FINAL.pdf](#)

[Walmart Settlement Participation Form - Exhibit K.pdf](#)

[Opioid Allocation Disbursement - Walmart \(estimated\).pdf](#)

## 12. Parks and Recreation

12.A For Possible Action: Discussion and possible action regarding the proposed acceptance of the Southern Nevada Public Lands Management Act ("SNPLMA") Round 18 grants and cooperative agreements from the U.S. Department of Interior - Bureau of Land Management, in the amount of \$1,883,875 with a \$50,000 cash match from Q18 - Quality of Life funds for the Buzzy's Ranch Water Rights and Wetland Enhancement Project and \$2,403,250 for the Carson River Trails Phase III - Prison Hill West Project, both effective November 17, 2022 through November 16, 2027. (Lyndsey Boyer, [lboyer@carson.org](mailto:lboyer@carson.org); Gregg Berggren, [gberggren@carson.org](mailto:gberggren@carson.org))

Staff Summary: Nominations for the Buzzy's Ranch Water Rights and Wetland Enhancement Project and Carson River Trails Phase III - Prison Hill West Project were both approved by the Secretary of Interior. The City recently received Notices of Award and Cooperative Agreements for both projects.

The award for the Carson River Trails Phase III - Prison Hill West Project does not include a cash match but the Parks, Recreation & Open Space Department would commit \$17,500 in staff time towards the project.

[L23AC00020-00 Notice of Award.pdf](#)

[L23AC00007 MOD 1 NOTICE OF AWARD.pdf](#)

## 13. Public Works

13.A For Possible Action: Discussion and possible action to adopt, on second reading, Bill No. 103, a proposed ordinance revising rates and fees for use of the Carson City sanitary landfill. (Darren Schulz, [dschulz@carson.org](mailto:dschulz@carson.org), Rick Cooley, [rcooley@carson.org](mailto:rcooley@carson.org))

Staff Summary: The proposed ordinance, if enacted, would increase the rates and fees charged for use of the Carson City sanitary landfill ("Landfill"), subject to certain exceptions.

[Draft Ord re Landfill Rates \(Second Read\) final.pdf](#)

[Draft Ord re Landfill Rates \(Second Read\) edits.pdf](#)

## 14. Community Development - Planning

14.A For Possible Action: Discussion and possible action regarding a request from Carson City ("Applicant") to introduce, on first reading, a proposed ordinance amending the zoning map to change the zoning from Limited Industrial ("LI") and Single-Family 1 Acre ("SF1A") to Single-Family 6,000 ("SF6") for Assessor's Parcel Number ("APN") 010-061-87; from SF1A to SF6 for the southern, approximately 4.5 acres of APN 010-061-84 addressed at 1601 Fairview Drive; and from LI to SF6 for the northern, approximately 9.7 acres of APN 010-061-76 addressed at 1700 Colorado Street. (Heather Ferris, hferris@carson.org)

Staff Summary: Through the annual review of the master plan and zoning map, the Board of Supervisors ("Board") and staff have identified the subject parcels as appropriate for consideration of mapping corrections. The proposed zoning map amendment will create consistency with the underlying master plan for the subject parcels. The parcels are located south of Fairview Drive, north of Colorado Street, and east of S. Saliman Road. Pursuant to Nevada Revised Statutes ("NRS") Chapter 237, a business impact statement is not required to be prepared with this ordinance.

[ZA-2023-0008 Ord.- DRAFT clean.doc](#)

[PC Staff Report with Supporting Material.pdf](#)

[DRAFT 01-25-2023 Minutes \(PC\) \(excerpt\).pdf](#)

14.B For Possible Action: Discussion and possible action regarding a request from Will Adler on behalf of Green Thumb Industries Inc. ("Applicant") to introduce, on first reading, a proposed ordinance providing location requirements for medical marijuana dispensaries and marijuana retail stores in the retail commercial ("RC") use district. (Hope Sullivan, hsullivan@carson.org)

Staff Summary: The Applicant is proposing to amend Carson City Municipal Code ("CCMC") 18.03.130 to allow marijuana retail stores and medical marijuana dispensaries in the RC use district within Township 15N, Range 20E, Sections 5, 6 and 8 which is generally the area along North Carson Street, north of Winnie Lane, west of Hot Springs Road and south of Arrowhead Drive and Medical Parkway. The Planning Commission has recommended approval of the proposed amendment to the zoning code, with a prohibition against medical marijuana dispensaries or marijuana retail stores north of Arrowhead Drive and Medical Parkway. Pursuant to Nevada Revised Statutes ("NRS") Chapter 237, a business impact statement is not required to be prepared with this ordinance.

[Ordinance 1st readng Marijuana locations ter clean.docx](#)

## 15. City Manager

15.A For Possible Action: Discussion and possible action regarding coordination of legislative activity on pending state legislation before the Nevada Legislature and whether to adopt an official policy position or direct staff to advocate for or against any such legislation, including the submittal of proposed amendatory language. (Stephen Wood, [swood@carson.org](mailto:swood@carson.org) and Nancy Paulson, [npaulson@carson.org](mailto:npaulson@carson.org))

Staff Summary: The Nevada Legislature is currently in its 82nd Regular Session. This item is for the Board of Supervisors to coordinate legislative efforts on pending state legislation that may have an impact on Carson City, including the adoption of official policy positions, if any, and direction to staff to advocate for or against any such legislation. Due to unpredictable timing constraints inherent in the legislative process, the City will maintain a list of legislation that the City has identified in advance and which may be discussed and acted on by the Board during this agenda item. A copy of the list will be posted not less than three days before the date of each Board of Supervisors meeting during which this agenda item appears and may be obtained at the following Internet website: <https://www.carson.org/legislature>.

## 16. Board of Supervisors

Non-Action Items:

City Manager Update

Status review of projects

Internal communications and administrative matters

Correspondence to the Board of Supervisors

Status reports and comments from the members of the Board

Staff comments and status report

### **Closed Non-Meeting to Confer with Management Representatives and Counsel:**

Following a recess or adjournment, the Carson City Board of Supervisors may gather to meet with its management representatives or to receive information from an attorney employed or retained by the City regarding potential and/or existing litigation involving matters over which the public body has supervision, control, jurisdiction or advisory power and to deliberate toward decisions on the matters.

## 17. Public Comment:\*\*

The public is invited at this time to comment on any matter that is not specifically included on the agenda as an action item. No action may be taken on a matter raised under this item of the agenda.

## 18. For Possible Action: To Adjourn as the Board of Supervisors

## Board of Health

**19. Call to Order - Board of Health**

**20. Roll Call**

**21. Public Comment:\*\***

The public is invited at this time to comment on any matter that is not specifically included on the agenda as an action item. No action may be taken on a matter raised under this item of the agenda.

**22. For Possible Action: Approval of Minutes -**

22.A December 15, 2022

[12-15-2022 Minutes \(BOH\).pdf](#)

**23. Health and Human Services**

23.A For Possible Action: Discussion and possible action regarding the proposed acceptance of a report from the Carson City Health Officer. (Nicki Aaker; NAaker@carson.org)

Staff Summary: This item is to provide an update on: (1) the Health Officer's activities; (2) clinical oversight and policy input; (3) training and education; and (4) general information for the Carson City Board of Health. Direction is requested from the Board of Health regarding the Health Officer's report concerning activities the Health Officer is engaged in both internally and externally for the Carson City Department of Health and Human Services.

[Health Officer's Report - Activities V2.pdf](#)

[Health Officer's Report.pdf](#)

23.B For Possible Action: Discussion and possible action regarding a proposed acceptance of the report of the Carson City Department of Health and Human Services ("CCHHS") Director, Nicki Aaker. (Nicki Aaker, naaker@carson.org)

Staff Summary: The CCHHS Director's report will concern: (1) an update on Title X funding; (2) an overview of CCHHS workforce challenges; (3) an update on relevant bills proposed during the 2023 Nevada legislative session; (4) an introduction of the Community Management Information System to be used for Carson City's Street Outreach program; and (4) requests for assistance for: (a) Title X funding, (b) workforce challenges, (c) continued support for Assembly Bill No. 118, (d) continued support for Carson City's Housing Plan, and (e) the Community Health Improvement Fund.

[CCHHS – Director's Report Presentation.pdf](#)

[Director's Report V3\\_NP edits.pdf](#)

23.C For Possible Action: Discussion and possible action regarding the third Community Health Needs Assessment (“CHNA”) of the Carson City Department of Health and Human Services (“CCHHS”) and a process by which to convene a stakeholder group to review the CHNA data and findings for the purpose of creating a Community Health Improvement Plan (“CHIP”). (Jeanne Freeman, [jmfreeman@carson.org](mailto:jmfreeman@carson.org))

Staff Summary: CCHHS is required to complete a CHNA, a CHIP and a Strategic Plan on a regular schedule as part of its Public Health reaccreditation process. CCHHS formed a team with other community partners who are also required to complete or participate in the CHNA. Once the CHNA is complete, the next step is to bring this collaborative group together, further expanding the diversity of the group, and complete the CHIP.

[Presentation Community Health Needs Assessment BOH 3.3.2023\\_V2.pdf](#)

[Quad County Regional 2022 CHNA Executive Summary Final.pdf](#)

[Quad County Regional 2022 CHNA Final Report.pdf](#)

#### **24. Public Comment:\*\***

The public is invited at this time to comment on and discuss any topic that is relevant to, or within the authority of this public body.

#### **25. For Possible Action: To Adjourn**

---

\*\*PUBLIC COMMENT LIMITATIONS - The Mayor and Supervisors meet at various times as different public bodies: the Carson City Board of Supervisors, the Carson City Liquor and Entertainment Board, the Carson City Redevelopment Authority, and the Carson City Board of Health. Each, as called to order, will provide at least two public comment periods in compliance with the minimum requirements of the Open Meeting Law prior to adjournment. No action may be taken on a matter raised under public comment unless the item has been specifically included on the agenda as an item upon which action may be taken. Public comment will be limited to three minutes per speaker to facilitate the efficient conduct of a meeting and to provide reasonable opportunity for comment from all members of the public who wish to speak. Testimony from a person who is directly involved with an item, such as City staff, an applicant or a party to an administrative hearing or appeal, is not considered public comment and is not subject to the three-minute time limitation.

Agenda Management Notice - Items on the agenda may be taken out of order; the public body may combine two or more agenda items for consideration; and the public body may remove an item from the agenda or delay discussion relating to an item on the agenda at any time.

Titles of agenda items are intended to identify specific matters. If you desire detailed information concerning any subject matter itemized within this agenda, you are encouraged to call the responsible agency or the City Manager’s Office. You are encouraged to attend this meeting and participate by commenting on any agenda item.

Notice to persons with disabilities: Members of the public who are disabled and require special assistance or accommodations at the meeting are requested to notify the City Manager's Office in writing at 201 North Carson Street, Carson City, NV, 89701, or by calling (775) 887-2100 at least 24 hours in advance.

To request a copy of the supporting materials for this meeting contact Rachael Evanson [revanson@carson.org](mailto:revanson@carson.org) or call (775) 887-2100.

This agenda and backup information are available on the City's website at [www.carson.org/agendas](http://www.carson.org/agendas) and at the City Manager's Office - City Hall, 201 N. Carson Street, Ste 2, Carson City, Nevada (775) 887-2100.

This notice has been posted at the following locations:

City Hall 201 North Carson Street

[www.carson.org/agendas](http://www.carson.org/agendas)

<http://notice.nv.gov>

**CARSON CITY BOARD OF SUPERVISORS AND REDEVELOPMENT AUTHORITY**

**Minutes of the February 2, 2023 Meeting**

**Page 1**

**DRAFT**

A regular meeting of the Carson City Board of Supervisors and Redevelopment Authority was scheduled for 8:30 a.m. on Thursday, February 2, 2023, in the Community Center Robert “Bob” Crowell Boardroom, 851 East William Street, Carson City, Nevada.

**PRESENT:**

Mayor Lori Bagwell  
Supervisor Stacey Giomi, Ward 1  
Supervisor Maurice White, Ward 2  
Supervisor Curtis Horton, Ward 3  
Supervisor Lisa Schuette, Ward 4

**STAFF:**

Nancy Paulson, City Manager  
Scott Hoen, Clerk-Recorder  
Dan Yu, Assistant District Attorney  
Stephanie Hicks, Deputy City Manager  
Tamar Warren, Senior Deputy Clerk

**NOTE:** A recording of these proceedings, the Board’s agenda materials, and any written comments or documentation provided to the Clerk, during the meeting, are part of the public record. These materials are available for review, in the Clerk’s Office, during regular business hours. All meeting minutes are available for review at: <https://www.carson.org/minutes>.

**1 - 4. CALL TO ORDER, ROLL CALL, INVOCATION, AND PLEDGE OF ALLEGIANCE**

(8:30:13) – Mayor Bagwell called the meeting to order at 8:30 a.m. Mr. Hoen called roll and noted the presence of a quorum. Peggy Locke, Assisting Minister at Hillside Foursquare Church, provided the invocation. At Mayor Bagwell’s request, Mr. Hoen led the Pledge of Allegiance.

**5. PUBLIC COMMENT**

(8:32:25) – Mayor Bagwell entertained public comments. Deni French read into the record a written statement urging the Board to practice the Plain Writing Act of 2010 which requires federal agencies to write “clear government communication that the public can understand and use.” He also urged a change to the City’s Master Plan to require an elevator for all public buildings over two stories high. Mr. French requested that the Consent Agenda read “public is offered opportunity to request a change from the Consent Agenda at the first statement offered for the community comment.” He was also concerned about the Carson Pines Apartments and wanted to see “safety issues come first.”

(8:36:23) – Joan Buchannan inquired about agenda item 23.A and highlighted the required business impact statement for businesses for landfill rate increases. She wished to understand whether such a statement was done for residences. Ms. Buchannan also inquired whether Carson City residents would receive a discount and whether any agreements existed with any cities besides Minden.

**CARSON CITY BOARD OF SUPERVISORS AND REDEVELOPMENT AUTHORITY**

**Minutes of the February 2, 2023 Meeting**

**Page 2**

**DRAFT**

**6. FOR POSSIBLE ACTION: APPROVAL OF MINUTES – JANUARY 5, 2023.**

(8:37:35) – Mayor Bagwell introduced the item and entertained comments, corrections, or a motion.

(8:37:40) – Supervisor Giomi moved to approve the minutes of the January 5, 2023 Board of Supervisors meeting as presented. The motion was seconded by Supervisor White and carried 5-0-0.

**CONSENT AGENDA**

(8:38:08) – Mayor Bagwell introduced the item and inquired whether the Board or the public wished to pull items from the Consent Agenda; however, none were forthcoming. She also entertained a motion.

(8:38:17) – Supervisor Giomi moved to approve the Consent Agenda consisting of items 7.A and 8.A as presented. Supervisor White seconded the motion.

<b>RESULT:</b>	<b>APPROVED (5-0-0)</b>
<b>MOVER:</b>	Supervisor Giomi
<b>SECONDER:</b>	Supervisor White
<b>AYES:</b>	Supervisors Giomi, Horton, Schuette, White, and Mayor Bagwell
<b>NAYS:</b>	None
<b>ABSTENTIONS:</b>	None
<b>ABSENT:</b>	None

**7. FINANCE**

**7.A FOR POSSIBLE ACTION: DISCUSSION AND POSSIBLE ACTION REGARDING THE REPORT ON THE CONDITION OF EACH FUND IN THE TREASURY AND THE STATEMENTS OF RECEIPTS AND EXPENDITURES THROUGH JANUARY 20, 2023, PER NRS 251.030 AND NRS 354.290.**

**8. PURCHASING AND CONTRACTS**

**8.A FOR POSSIBLE ACTION: DISCUSSION AND POSSIBLE ACTION REGARDING AUTHORIZATION TO PURCHASE (1) TWO GENETEC INC. MODEL SV-4020EX-R26-520T-20-216 ARCHIVERS (“ARCHIVERS”) THROUGH POWERCOMM SOLUTIONS, INC. (“POWERCOMM”) FOR A NOT TO EXCEED AMOUNT OF \$119,973, AND (2) ONE YEAR OF 24/7 SUPPORT SERVICES FROM GENETEC INC., THROUGH POWERCOMM FOR A NOT TO EXCEED AMOUNT OF \$5,915.**

**END OF CONSENT AGENDA**

**ORDINANCES, RESOLUTIONS, AND OTHER ITEMS**

**9. ITEM(S) PULLED FROM THE CONSENT AGENDA WILL BE HEARD AT THIS TIME**



**CARSON CITY BOARD OF SUPERVISORS AND REDEVELOPMENT AUTHORITY**

**Minutes of the February 2, 2023 Meeting**

**Page 3**

**DRAFT**

No items were pulled from the Consent Agenda.

**10. CITY MANAGER**

**10.A FOR POSSIBLE ACTION: DISCUSSION AND POSSIBLE ACTION REGARDING THE APPOINTMENT OF TWO MEMBERS TO THE HISTORIC RESOURCES COMMISSION ("HRC"), EACH FOR A FOUR-YEAR TERM THAT EXPIRES IN JANUARY 2027.**

(8:38:36) – Mayor Bagwell introduced the item and explained that under the City’s Policies and Procedures for Boards and Committees, the City Manager had waived the requirement that the applicants to the Historic Resources Commission be interviewed in person or electronically by the Board. She explained that the only new candidate to fill the Historic District property owner and resident position was Joan Wright who met all the requirements. She noted that the Commission attracted a small pool of candidates due to the restrictions and deferred the decision to the Board. Supervisor White noted that late material had been received from Ms. Wright reaffirming her willingness to serve. Mayor Bagwell explained that no public comments would be taken on appointments and entertained a motion.

**(8:40:28) – Supervisor White moved to reappoint Lou Ann Speulda-Drews and to appoint Joan Wright, each for a full term that expires in January 2027. Supervisor Schuette seconded the motion.**

<b>RESULT:</b>	<b>APPROVED (5-0-0)</b>
<b>MOVER:</b>	Supervisor White
<b>SECONDER:</b>	Supervisor Schuette
<b>AYES:</b>	Supervisors Giomi, Horton, Schuette, White, and Mayor Bagwell
<b>NAYS:</b>	None
<b>ABSTENTIONS:</b>	None
<b>ABSENT:</b>	None

**10.B FOR POSSIBLE ACTION: DISCUSSION AND POSSIBLE ACTION REGARDING THE APPOINTMENT OF ONE MEMBER TO THE 9-1-1 SURCHARGE ADVISORY COMMITTEE (“COMMITTEE”), AS THE REPRESENTATIVE OF A LOCAL EXCHANGE CARRIER FOR A PARTIAL TERM EXPIRING IN DECEMBER 2023.**

(8:40:54) – Mayor Bagwell introduced the item noting that this position was also very specific and difficult to fill. She then entertained a motion.

**(8:41:22) – Supervisor Giomi moved to appoint Charles "Andy" Polisso as the representative for a local exchange carrier for a term expiring in December 2023. Supervisor White seconded the motion.**

<b>RESULT:</b>	<b>APPROVED (5-0-0)</b>
<b>MOVER:</b>	Supervisor Giomi
<b>SECONDER:</b>	Supervisor White
<b>AYES:</b>	Supervisors Giomi, Horton, Schuette, White, and Mayor Bagwell
<b>NAYS:</b>	None
<b>ABSTENTIONS:</b>	None
<b>ABSENT:</b>	None

**CARSON CITY BOARD OF SUPERVISORS AND REDEVELOPMENT AUTHORITY**

**Minutes of the February 2, 2023 Meeting**

**Page 4**

**DRAFT**

**11. Recess as the Board of Supervisors**

(8:41:41) – Mayor Bagwell recessed the Board of Supervisors meeting.

**REDEVELOPMENT AUTHORITY**

**12. CALL TO ORDER - REDEVELOPMENT AUTHORITY**

(8:41:47) – Chairperson Bagwell called the Redevelopment Authority Meeting to order.

**13. ROLL CALL**

(8:41:56) – Mr. Hoen called roll and noted the presence of a quorum.

**14. PUBLIC COMMENT**

(8:42:08) – Chairperson Bagwell entertained public comments; however, none were forthcoming.

**15. FOR POSSIBLE ACTION: APPROVAL OF MINUTES – JANUARY 5, 2023**

(8:42:17) – Chairperson Bagwell entertained comments of corrections and when none were forthcoming, a motion.

**(8:42:22) – Vice Chair Giomi moved to approve the minutes of the January 5, 2023 Redevelopment Authority meeting. The motion was seconded by Member White and carried 5-0-0.**

**16. CITY MANAGER**

**16.A FOR POSSIBLE ACTION: DISCUSSION AND POSSIBLE ACTION REGARDING THE APPOINTMENT OF THREE MEMBERS TO THE REDEVELOPMENT AUTHORITY CITIZENS COMMITTEE ("RACC"), ONE FOR THE POSITION OF BUSINESS OPERATOR OR PROPERTY OWNER FROM REDEVELOPMENT AREA 2 FOR A FULL TERM THAT WILL EXPIRE IN JANUARY 2026, AND TWO FOR THE POSITIONS OF CITIZEN-AT-LARGE WITH EACH TO FILL PARTIAL TERMS ENDING IN JANUARY 2025.**

(8:43:04) – Chairperson Bagwell introduced the item. Both Chairperson Bagwell and Member White read into the record prepared disclosure statements, advised of no disqualifying conflict of interest, and stated that they would participate in discussion and action. Chairperson Bagwell noted that only one candidate, Lee Kennedy, had applied for the Business Operator or Property Owner position from Redevelopment Area 2 and entertained discussion or a motion.

**(8:46:30) – Member Schuette moved to appoint Lee Kennedy to the Redevelopment Area 2 position for a full term expiring in January 2026. Member Horton seconded the motion.**

**CARSON CITY BOARD OF SUPERVISORS AND REDEVELOPMENT AUTHORITY**

**Minutes of the February 2, 2023 Meeting**

**Page 5**

**DRAFT**

<b>RESULT:</b>	<b>APPROVED (5-0-0)</b>
<b>MOVER:</b>	Member Schuette
<b>SECONDER:</b>	Member Horton
<b>AYES:</b>	Members Horton, Schuette, White, Vice Chair Giomi, and Chair Bagwell
<b>NAYS:</b>	None
<b>ABSTENTIONS:</b>	None
<b>ABSENT:</b>	None

(8:47:09) – Chairperson Bagwell noted that the Citizen-at-Large applicant interviews would be conducted in the following order: 1) Margaret Green-Wilson; 2) Richard Nagel; 3) Ashley Ackerman. David Lambin was not present for the interview.

These interviews may be viewed on the City’s website at:

[https://carsoncity.granicus.com/player/clip/2177?view\\_id=2&redirect=true&h=3641c5a043c8542623125fc9665:dfebc](https://carsoncity.granicus.com/player/clip/2177?view_id=2&redirect=true&h=3641c5a043c8542623125fc9665:dfebc)

(8:58:05) – Mayor Bagwell explained the interview process to each candidate and each Authority member asked the same questions to all the candidates. At the end of the interviews, Chairperson Bagwell entertained discussion. Member Schuette called the decision difficult and highlighted the concept of cooperation/collaboration and the making of “decisions that are good for the community” brought forward by Ms. Green-Wilson. She also praised Mr. Nagel’s ideas of “celebrating what we have in Carson City to encourage tourists.” Member Schuette thanked Ms. Ackerman for her vision of the community and believed that she was comfortable with any of the candidates. She later added that Ms. Green-Wilson would be her top candidate. She was also encouraged by Ms. Ackerman’s youth and the concept of giving back to the community. Member White explained that he was trying to find institutional knowledge/experience and the “new blood.” He believed that Ms. Green-Wilson would bring experience and Ms. Ackerman would bring her real estate expertise to the Committee.

(9:20:07) – Vice Chair Giomi believed that Ms. Green-Wilson provided experience, Mr. Nagel brought his international knowledge, and Ms. Ackerman brought forth her Carson City knowledge, real estate experience, and enthusiasm. Member Horton also explained that all three candidates were eager to serve and qualified. He noted that Mr. Nagel and Ms. Green-Wilson would be his two choices for the position. Chairperson Bagwell noted that the Authority by consensus had selected Ms. Green-Wilson as their top candidate as she would also support her appointment due to her desire to strengthen the infrastructure. She added that she was looking for a well-rounded and balanced Committee with different skill sets, citing the experience of Mr. Kennedy in the business arena. Chairperson Bagwell highlighted Ms. Ackerman’s out-of-the-box suggestions and believed that the rest of the Committee members could fill the role Mr. Nagel could fill. Member Schuette stated that her second vote would go to Mr. Nagel; however, she would also support Ms. Ackerman’s appointment. Chairperson Bagwell entertained a motion.

**(9:26:38) – Vice Chair Giomi moved to appoint Margaret Green-Wilson and Ashley Ackerman to the Citizen-at-Large positions, each to fill partial terms expiring in January 2025. Member White seconded the motion.**

**CARSON CITY BOARD OF SUPERVISORS AND REDEVELOPMENT AUTHORITY**

**Minutes of the February 2, 2023 Meeting**

**Page 6**

**DRAFT**

<b>RESULT:</b>	<b>APPROVED (5-0-0)</b>
<b>MOVER:</b>	Vice Chair Giomi
<b>SECONDER:</b>	Member White
<b>AYES:</b>	Members Horton, Schuette, White, Vice Chair Giomi, and Chair Bagwell
<b>NAYS:</b>	None
<b>ABSTENTIONS:</b>	None
<b>ABSENT:</b>	None

**17. FINANCE**

**17.A FOR POSSIBLE ACTION: DISCUSSION AND POSSIBLE ACTION REGARDING A RESOLUTION TO AUGMENT AND AMEND THE CARSON CITY REDEVELOPMENT AUTHORITY FISCAL YEAR 2022-2023 BUDGET IN THE AMOUNT OF \$2,079,613.**

(9:27:27) – Chairperson Bagwell introduced the item and entertained member or public comments; however, none were forthcoming. Member Schuette thanked Chief Financial Officer (CFO) Sheri Russell-Benabou for responding to her questions via telephone. Ms. Russell-Benabou announced a vacancy on the Audit Committee. Chairperson Bagwell entertained a motion.

**(9:28:33) – Vice Chair Giomi moved to adopt Resolution No. 2023-RA-R-1. The motion was seconded by Member White.**

<b>RESULT:</b>	<b>APPROVED (5-0-0)</b>
<b>MOVER:</b>	Vice Chair Giomi
<b>SECONDER:</b>	Member White
<b>AYES:</b>	Members Horton, Schuette, White, Vice Chair Giomi, and Chair Bagwell
<b>NAYS:</b>	None
<b>ABSTENTIONS:</b>	None
<b>ABSENT:</b>	None

**18. PUBLIC COMMENT**

(9:29:14) – Chairperson Bagwell entertained final public comments. Deni French thanked all the candidates and noted that the Nevada State Prison should be considered a Redevelopment District “as part of the City’s history.” He also wished to see insects as “part of the Redevelopment consideration.”

**19. FOR POSSIBLE ACTION: TO ADJOURN AS THE REDEVELOPMENT AUTHORITY**

(9:32:10) – Chairperson Bagwell adjourned the Redevelopment Authority meeting at 9:32 a.m.

**20. RECONVENE AS THE BOARD OF SUPERVISORS**

**CARSON CITY BOARD OF SUPERVISORS AND REDEVELOPMENT AUTHORITY**

**Minutes of the February 2, 2023 Meeting**

**Page 7**

**DRAFT**

(9:32:13) – Mayor Bagwell reconvened the Board of Supervisors meeting. A quorum was still present.

**21. FINANCE**

**21.A FOR POSSIBLE ACTION: DISCUSSION AND POSSIBLE ACTION REGARDING A RESOLUTION TO AUGMENT AND AMEND THE CARSON CITY FISCAL YEAR 2022-2023 BUDGET IN THE AMOUNT OF \$130,804,211.**

(9:32:17) – Mayor Bagwell introduced the item. Ms. Russell-Benabou reviewed the augmentation for each of the funds, incorporated into the record, and responded to clarifying questions. Mayor Bagwell clarified that the Board had “set a policy for ending fund balance. Our overarching goal is to get to that two-month savings account of 16 percent.” She also suggested renaming the Tiberon Project to move away from the vendor name. Mayor Bagwell entertained Board and/or public comments and when none were forthcoming, a motion.

**(9:49:14) – Supervisor Horton moved to adopt Resolution No. 2023-R-2. Supervisor Schuette seconded the motion.**

<b>RESULT:</b>	<b>APPROVED (5-0-0)</b>
<b>MOVER:</b>	Supervisor Horton
<b>SECONDER:</b>	Supervisor Schuette
<b>AYES:</b>	Supervisors Giomi, Horton, Schuette, White, and Mayor Bagwell
<b>NAYS:</b>	None
<b>ABSTENTIONS:</b>	None
<b>ABSENT:</b>	None

**21.B FOR POSSIBLE ACTION: DISCUSSION AND POSSIBLE ACTION TO ADOPT, ON SECOND READING, BILL NO. 101, A PROPOSED ORDINANCE AUTHORIZING THE ISSUANCE BY CARSON CITY OF ITS "GENERAL OBLIGATION (LIMITED TAX) INFRASTRUCTURE SALES TAX BONDS (ADDITIONALLY SECURED BY PLEDGED REVENUES), SERIES 2023" IN THE AGGREGATE PRINCIPAL AMOUNT NOT TO EXCEED \$5,550,000.**

(9:49:53) – Mayor Bagwell introduced the item and Ms. Russell-Benabou stated that there were no changes to the bill since the first reading. She also reported that with the still declining interest rates, the City was well-positioned for the sale. Mayor Bagwell entertained public comments and when none were forthcoming, a motion.

**(9:50:49) – Supervisor White moved to adopt, on second reading, Bill No. 101, Ordinance No. 2023-1. The motion was seconded by Supervisor Giomi.**

<b>RESULT:</b>	<b>APPROVED (5-0-0)</b>
<b>MOVER:</b>	Supervisor White
<b>SECONDER:</b>	Supervisor Giomi
<b>AYES:</b>	Supervisors Giomi, Horton, Schuette, White, and Mayor Bagwell
<b>NAYS:</b>	None
<b>ABSTENTIONS:</b>	None
<b>ABSENT:</b>	None

**CARSON CITY BOARD OF SUPERVISORS AND REDEVELOPMENT AUTHORITY**

**Minutes of the February 2, 2023 Meeting**

**Page 8**

**DRAFT**

**22. FIRE**

**22.A FOR POSSIBLE ACTION: DISCUSSION AND POSSIBLE ACTION REGARDING A FEDERAL GRANT AWARD IN THE AMOUNT OF \$2,036,493 THROUGH NOVEMBER 17, 2028, WITH A LOCAL MATCH OBLIGATION NOT TO EXCEED \$30,000, FOR CARSON CITY TO PERFORM WILDFIRE FUELS REDUCTION WORK IN WESTERN CARSON CITY (“PROJECT”) THROUGH ROUND 18 OF THE SOUTHERN NEVADA PUBLIC LAND MANAGEMENT ACT’S (“SNPLMA”) HAZARDOUS FUELS REDUCTION AND WILDFIRE PREVENTION PROGRAM.**

(9:51:20) – Mayor Bagwell introduced the item. Carson City Fire Chief Sean Slamon indicated that items 22.A, 22.B, and 22.C were all related to the Southern Nevada Public Land Management Act’s (SNPLMA) Hazardous Fuels Reduction and Wildfire Prevention program grants to clear and treat hazardous vegetation. He added that the grant allows the Fire Department to hire seasonal firefighters to clear hazardous material and fill a Fuels Management Grants Administrator position. Mayor Bagwell referenced a written public comment, incorporated into the record, and inquired whether local businesses could be utilized for equipment rentals or services. Battalion Chief Jason Danen clarified that the current program was “self-service” because the Fire Department supplied trailers, but the labor was provided by the homeowners. Supervisor Giomi noted that the equipment was already owned by the Fire Department and no capital would be spent on equipment. Mayor Bagwell entertained public comments.

(9:56:05) – Mr. French believed that homeowners may not be aware of the fire hazards and recommended educating them on what vegetation could be cleared and what should be left. Battalion Chief Danen clarified that the Fire department is available to help homeowners with what vegetation to clear to protect their homes. There were no additional public comments; therefore, Mayor Bagwell entertained a motion.

**(9:57:52) – Supervisor Giomi moved to accept the grant award as presented. Supervisor Schuette seconded the motion.**

<b>RESULT:</b>	<b>APPROVED (5-0-0)</b>
<b>MOVER:</b>	Supervisor Giomi
<b>SECONDER:</b>	Supervisor Schuette
<b>AYES:</b>	Supervisors Giomi, Horton, Schuette, White, and Mayor Bagwell
<b>NAYS:</b>	None
<b>ABSTENTIONS:</b>	None
<b>ABSENT:</b>	None

**22.B FOR POSSIBLE ACTION: DISCUSSION AND POSSIBLE ACTION REGARDING A FEDERAL GRANT AWARD IN THE AMOUNT OF \$147,290 THROUGH DECEMBER 26, 2028, WITH NO LOCAL MATCH OBLIGATION, FOR CARSON CITY TO PROVIDE ELIGIBLE HOMEOWNERS WITH TRAILERS AND DUMPSTERS FOR VEGETATION REMOVAL (“PROJECT”) THROUGH ROUND 18 OF THE SOUTHERN NEVADA PUBLIC LAND MANAGEMENT ACT’S (“SNPLMA”) HAZARDOUS FUELS REDUCTION AND WILDFIRE PREVENTION PROGRAM.**

**CARSON CITY BOARD OF SUPERVISORS AND REDEVELOPMENT AUTHORITY**

**Minutes of the February 2, 2023 Meeting**

**Page 9**

**DRAFT**

(9:58:07) – Mayor Bagwell introduced the item and explained that the grant is not for major equipment purchases. Battalion Chief Danen clarified that some minor equipment such as tarps would be purchased. Mayor Bagwell entertained public comments.

(10:00:01) – Chris Pattison with Carson Demolition referenced his written public comment and noted that even though the grants were for fuel and driver expenses, his business would be able to assist by volunteering time and equipment. Supervisor White inquired about the in-kind match for the homeowners and was informed that the funds were broken down over six years and they included the number of hours homeowners would spend to load the trailers and the administrative portion involved scheduling the dumpster time. Battalion Chief Danen also clarified that this particular grant was for West Carson City only. Supervisor White explained that he could support the program if it contained a component that would include involving private entrepreneurs. Fire Chief Slamon clarified that the program did not preclude any private business from contracting with a homeowner to perform cleanup efforts, adding that the program was focused on protecting the community.

(10:08:03) – Supervisor Schuette called the grant “important” for fuel reduction. She believed that the homeowners who book a trailer would need to do the work themselves and she believed it was “a lot of work.” Mayor Bagwell inquired about additional grants to expand the program because of the long waiting list and providing opportunities for local businesses to offer their services as part of the expansion. Discussion ensued regarding the use of local businesses to provide the trailers and Supervisor Giomi gave historical data on the program, noting that the driver fees were not as expensive as utilizing the local businesses. He also suggested having a list of local vendors in the region that can provide their dumpsters when all the Fire Department trailers are booked. Mayor Bagwell suggested applying for additional grants to expedite the clearing of the brush and to involve local businesses. She also recommended that local businesses market their clearing services for those who receive the trailers but are unable to do the work themselves – including the downed trees from the recent storms. Supervisor White noted that he would support the program based on the discussion to involve local businesses. Mayor Bagwell entertained a motion.

**(10:18:55) – Supervisor Schuette moved to accept the grant award as presented. Supervisor Horton seconded the motion.**

<b>RESULT:</b>	<b>APPROVED (5-0-0)</b>
<b>MOVER:</b>	Supervisor Schuette
<b>SECONDER:</b>	Supervisor Horton
<b>AYES:</b>	Supervisors Giomi, Horton, Schuette, White, and Mayor Bagwell
<b>NAYS:</b>	None
<b>ABSTENTIONS:</b>	None
<b>ABSENT:</b>	None

**22.C FOR POSSIBLE ACTION: DISCUSSION AND POSSIBLE ACTION REGARDING A PROPOSED RECLASSIFICATION OF THE WILDLAND FUELS MANAGEMENT OFFICER POSITION (CURRENTLY UNCLASSIFIED, P601) TO THE POSITION OF FUELS MANAGEMENT GRANTS ADMINISTRATOR (CLASSIFIED, P202).**

**CARSON CITY BOARD OF SUPERVISORS AND REDEVELOPMENT AUTHORITY**

**Minutes of the February 2, 2023 Meeting**

**Page 10**

**DRAFT**

(10:19:19) – Mayor Bagwell introduced the item. Fire Chief Slamon presented the Staff Report, incorporated into the record, and responded to clarifying questions. Supervisor White was in favor of the public education component of the grant. Mayor Bagwell entertained public comments and when none were forthcoming, a motion.

**(10:21:47) – Supervisor Schuette moved to reclassify the Wildland Fuel Management Officer position to a Fuels Management Grants Administrator position. Supervisor Giomi seconded the motion.**

<b>RESULT:</b>	<b>APPROVED (5-0-0)</b>
<b>MOVER:</b>	Supervisor Schuette
<b>SECONDER:</b>	Supervisor Giomi
<b>AYES:</b>	Supervisors Giomi, Horton, Schuette, White, and Mayor Bagwell
<b>NAYS:</b>	None
<b>ABSTENTIONS:</b>	None
<b>ABSENT:</b>	None

(10:22:24) – Mayor Bagwell recessed the meeting.

(10:32:20) – Mayor Bagwell reconvened the meeting. A quorum was still present.

**23. PUBLIC WORKS**

**23.A FOR POSSIBLE ACTION: DISCUSSION AND POSSIBLE ACTION: (1) REGARDING A BUSINESS IMPACT STATEMENT CONCERNING A PROPOSED ORDINANCE REVISING RATES AND FEES FOR USE OF THE CARSON CITY SANITARY LANDFILL; AND (2) TO INTRODUCE, ON FIRST READING, A PROPOSED ORDINANCE REVISING RATES AND FEES FOR USE OF THE CARSON CITY SANITARY LANDFILL.**

(10:32:24) – Mayor Bagwell introduced the item. Public Works Director Darren Schulz gave background on previous Board direction to Staff and presented the Staff Report which is incorporated into the record. In response to an earlier public comment, Mayor Bagwell clarified that the Board had given direction to Staff to “hold our residents harmless” by ensuring minimum impact to Carson City residents. She highlighted the fact that the information was distributed to non-Carson City businesses as well, which the City was not obligated to do. Supervisor Giomi clarified “what we’re doing here does not affect what Waste Management will charge our residents in Carson City.”

(10:35:45) – Mayor Bagwell also opened items 23.B and 23.C for concurrent discussion. Supervisor Giomi called the rate structure a balancing act and was not in favor of continuing to do contracts. He believed that the landfill revenue helped maintain the City’s structures. He suggested lowering the proposed Municipal Solid Waste Out-of-County Fees (1,000 lbs. or greater) to \$68 instead of the proposed \$74. Mr. Schulz cautioned against making decisions today that would impact the future of the landfill, including capacity issues. Supervisor Giomi also wished to consider giving the other municipalities an opportunity to budget. Mayor Bagwell entertained public comments.



**CARSON CITY BOARD OF SUPERVISORS AND REDEVELOPMENT AUTHORITY**

**Minutes of the February 2, 2023 Meeting**

**Page 11**

**DRAFT**

(10:48:26) – Gardnerville Town Manager Erik Nilssen thanked the Public Works staff and noted that they used the Carson City Landfill exclusively, noting that it was \$20 less than Lockwood. He explained that Gardnerville residents would also see an increase in their waste removal fees; however, with the new Landfill rates in Carson City, Gardnerville would have to spend their increased revenue on waste disposal. Mr. Nilssen had expected a rate increase but not as high as 30 percent. He recommended a 15 percent increase this year and another 15 percent increase the following year to “give me a little time to adjust.”

(10:50:55) – Tillio Olcese, Owner and President of Olcese Waste Services stated that by paying higher fees than Waste Management, he would be at a competitive disadvantage and requested “a level playing field.” Mr. Pattison also requested having the same competitive rates as Waste Management. Public Works Operations Manager Rick Cooley explained that Waste Management would pay the higher rate for out-of-county waste. Deputy District Attorney Adam Tully clarified that the proposed ordinance (Section 5.b) should be revised to include the new out-of-county rates for franchisees for clarity purposes. Supervisor White recommended being business-friendly to local businesses. Mr. Cooley explained the methodology used for the increased rates to Supervisor Schuette. Mayor Bagwell entertained a motion for item 23.A.

**(11:00:30) – Supervisor Schuette moved to approve the business impact statement as presented and introduce, on first reading, Bill No. 103 with the addition of the conforming changes by the District Attorney’s Office regarding the Waste Management out-of-county rates. Supervisor White seconded the motion.**

<b>RESULT:</b>	<b>APPROVED (5-0-0)</b>
<b>MOVER:</b>	Supervisor Schuette
<b>SECONDER:</b>	Supervisor White
<b>AYES:</b>	Supervisors Giomi, Horton, Schuette, White, and Mayor Bagwell
<b>NAYS:</b>	None
<b>ABSTENTIONS:</b>	None
<b>ABSENT:</b>	None

**23.B FOR POSSIBLE ACTION: DISCUSSION AND POSSIBLE ACTION REGARDING A PROPOSED INTERLOCAL AGREEMENT (“AGREEMENT”) BETWEEN CARSON CITY AND THE TOWN OF MINDEN (“MINDEN”) TO PROVIDE MINDEN A DISCOUNTED RATE FOR ONE YEAR TO DISPOSE OF SPECIFIED SOLID WASTE AT THE CARSON CITY SANITARY LANDFILL (“LANDFILL”).**

(11:01:15) – Based on the above discussion and public comment, Mayor Bagwell entertained a motion.

**(11:00:30) – Supervisor Schuette moved to approve the Interlocal Agreement as presented for both items 23.B and 23.C. Supervisor White seconded the motion.**

<b>RESULT:</b>	<b>APPROVED (4-1-0)</b>
<b>MOVER:</b>	Supervisor Schuette
<b>SECONDER:</b>	Supervisor White
<b>AYES:</b>	Supervisors Horton, Schuette, White, and Mayor Bagwell
<b>NAYS:</b>	Supervisor Giomi
<b>ABSTENTIONS:</b>	None
<b>ABSENT:</b>	None

**CARSON CITY BOARD OF SUPERVISORS AND REDEVELOPMENT AUTHORITY**

**Minutes of the February 2, 2023 Meeting**

**Page 12**

**DRAFT**

**23.C FOR POSSIBLE ACTION: DISCUSSION AND POSSIBLE ACTION REGARDING A PROPOSED INTERLOCAL AGREEMENT (“AGREEMENT”) BETWEEN CARSON CITY AND THE TOWN OF GARDNERVILLE (“GARDNERVILLE”) TO PROVIDE GARDNERVILLE A DISCOUNTED RATE FOR ONE YEAR TO DISPOSE OF SPECIFIED SOLID WASTE AT THE CARSON CITY SANITARY LANDFILL (“LANDFILL”).**

Please see discussion during item 23.A and motion in 23.B.

**24. BOARD OF SUPERVISORS**

**NON-ACTION ITEMS.**

**FUTURE AGENDA ITEMS**

**STATUS REVIEW OF PROJECTS**

**INTERNAL COMMUNICATIONS AND ADMINISTRATIVE MATTERS**

**CORRESPONDENCE TO THE BOARD OF SUPERVISORS**

**STATUS REPORTS AND COMMENTS FROM THE MEMBERS OF THE BOARD**

**STAFF COMMENTS AND STATUS REPORT**

(11:02:30) – Mayor Bagwell introduced the item. Ms. Paulson reminded the Board that the Legislative Session will begin on Monday and Staff will be reading over 1,000 bills in the next few months. She also explained that the next meeting will kick off the City’s 2024 budget process. Mayor Bagwell announced that Western Nevada College has renamed its technical education department to Workforce, Career and Technical Education, in a new partnership with Michael Hohl Subaru and Subaru of America. Michael Hohl Subaru had also donated a new vehicle to ensure Auto Mechanics students learn auto repair skills on the latest vehicles. Supervisor Giomi updated the Board on the Nevada Association of Counties bills (AB47, SB20, SB21, SB22, and SB41). Supervisor Schuette announced that she had been invited to attend a national roundtable task force to discuss workforce housing, homelessness, and other issues most communities are facing. Supervisor White raised the issue of not accepting solar panels in the City’s Landfill due to the toxicity of the chemicals that would harm the employees and citizens, and the large volume of solar panels that will be discarded. He added that many landfills are not accepting solar panels now and suggested working on a policy immediately.

**CLOSED NON-MEETING TO CONFER WITH MANAGEMENT REPRESENTATIVES AND COUNSEL.**

This item did not take place.

**25. PUBLIC COMMENT**

(11:12:58) – Mayor Bagwell entertained final public comments. Mr. French stated his opposition to the Silver Oak Apartments project for safety reasons. He was also disappointed that his request for elevators for the three-story buildings was not discussed during the project hearing in the Planning Commission meeting. Mr. French announced that a Land Use Planning Advisory Council Meeting will be held on February 3, 2023. He also stated that the State of Nevada Commission on Peace Officer Standards and Training will meet on February 9, 2023 and

**CARSON CITY BOARD OF SUPERVISORS AND REDEVELOPMENT AUTHORITY**

**Minutes of the February 2, 2023 Meeting**

**Page 13**

**DRAFT**

one of the agenda items is: *Discussion regarding the revision of NAC 289.110(4)(b) to update or make changes as it relates to marijuana offenses.*

**26. FOR POSSIBLE ACTION: TO ADJOURN THE BOARD OF SUPERVISORS**

(11:17:16) – Mayor Bagwell adjourned the Board of Supervisors meeting at 11:17 a.m.

The Minutes of the February 2, 2023 Carson City Board of Supervisors meeting are so approved on this 2<sup>nd</sup> day of March, 2023.

\_\_\_\_\_  
LORI BAGWELL, Mayor

ATTEST:

\_\_\_\_\_  
SCOTT HOEN, Clerk-Recorder



## STAFF REPORT

**Report To:** Board of Supervisors **Meeting Date:** March 2, 2023

**Staff Contact:** Sheri Russell-Benabou, Chief Financial Officer

**Agenda Title:** For Possible Action: Discussion and possible action regarding the report on the condition of each fund in the treasury and the statements of receipts and expenditures through February 17, 2023, per NRS 251.030 and NRS 354.290. (Sheri Russell-Benabou, srussell@carson.org)

Staff Summary: NRS 251.030 requires the Chief Financial Officer (for the purpose of the statute acting as the County Auditor) to report to the Board of Supervisors, at each regular meeting thereof, the condition of each fund in the treasury. NRS 354.290 requires the County Auditor to report to the Board of Supervisors a statement of revenues and expenditures based on the accounts and funds as were used in the budget. A more detailed accounting is available on the City's website – [www.carson.org](http://www.carson.org).

**Agenda Action:** Formal Action / Motion **Time Requested:** Consent

### **Proposed Motion**

I move to accept the report.

### **Board's Strategic Goal**

Efficient Government

### **Previous Action**

N/A

### **Background/Issues & Analysis**

A "Condition of the Treasury Report" is attached indicating the beginning balance, receipts, disbursements, and the ending balance of each cash account for every fund in the City as of February 17, 2023.

It is important to note that there will always be timing differences with these balances - for example, while all departments take deposits to the bank on a daily basis, there is usually a delay between when the reports are prepared and when they are entered into the system.

### **Applicable Statute, Code, Policy, Rule or Regulation**

NRS 251.030 and 354.290

### **Financial Information**

**Is there a fiscal impact?** No

**If yes, account name/number:**

**Is it currently budgeted?**

**Explanation of Fiscal Impact:**

**Alternatives**

N/A

**Attachments:**

[BOS Cash Report 02-17-2023.pdf](#)

**Board Action Taken:**

Motion: \_\_\_\_\_

1) \_\_\_\_\_

2) \_\_\_\_\_

Aye/Nay

\_\_\_\_\_  
\_\_\_\_\_  
\_\_\_\_\_  
\_\_\_\_\_  
\_\_\_\_\_

\_\_\_\_\_  
(Vote Recorded By)

# CONDITION OF THE TREASURY REPORT

CASH ACTIVITY BETWEEN 2/3/2023 & 2/17/2023

FUND	FUND NAME	BEGINNING BALANCE	RECEIPTS	DISBURSEMENTS	ENDING BALANCE
101	GENERAL FUND	\$ 23,426,298.48	\$ 1,186,787.19	\$ 2,114,245.09	\$ 22,498,840.58
201	AIRPORT FUND	0.07	-	-	0.07
202	COOPERATIVE EXTENSION FUND	334,111.71	1,292.92	297.46	335,107.17
208	SUPPLEMENTAL INDIGENT FUND	2,946,414.23	11,614.66	14,715.44	2,943,313.45
210	CAPITAL PROJECTS FUND	25,703,493.75	5,049.82	48,180.02	25,660,363.55
215	SENIOR CENTER FUND	497,877.89	5,049.82	26,517.59	476,410.12
225	CARSON CITY TRANSIT FUND	402,352.62	20,477.84	2,434.97	420,395.49
230	LIBRARY GIFT FUND	137,028.21	204.22	-	137,232.43
235	LANDSCAPE MAINTENANCE FUND	534,196.75	427.50	4,793.17	529,831.08
236	ADMINISTRATIVE ASSESSMENT FUND	26,250.04	1,456.00	499.68	27,206.36
237	S. CARSON NEIGHBORHOOD IMPROV. DIST.	71,612.94	117.37	6,730.00	65,000.31
240	TRAFFIC/TRANSPORTATION FUND	21,726.99	155.00	173.59	21,708.40
245	CAMPO FUND	(27,987.00)	-	5,248.87	(33,235.87) <sup>1</sup>
250	REGIONAL TRANSPORTATION FUND	4,588,055.95	1,134.54	47,812.65	4,541,377.84
253	V & T INFRASTRUCTURE FUND	2,930,162.42	-	720.81	2,929,441.61
254	QUALITY OF LIFE FUND	5,553,060.70	212.58	33,769.54	5,519,503.74
256	STREET MAINTENANCE FUND	1,481,523.02	-	108,958.55	1,372,564.47
275	GRANT FUND	18,387,083.69	276,671.96	249,879.25	18,413,876.40
280	COMMISSARY FUND	127,060.90	-	3,570.25	123,490.65
287	911 SURCHARGE FUND	898,546.91	108.00	6,316.24	892,338.67
310	INFRASTRUCTURE TAX FUND	1,850,521.05	50,000.00	216,554.98	1,683,966.07
340	EXTRAORDINARY MAINTENANCE FUND	11,078,260.82	-	872.73	11,077,388.09
350	RESIDENTIAL CONSTRUCTION TAX FUND	1,050,058.43	-	-	1,050,058.43
410	DEBT SERVICE FUND	1,343,257.77	-	-	1,343,257.77
501	AMBULANCE FUND	4,113,041.01	119,916.39	137,842.44	4,095,114.96
505	STORMWATER FUND	816,809.58	69,606.74	16,321.15	870,095.17
510	WASTEWATER FUND	24,231,038.86	385,356.96	808,219.22	23,808,176.60
520	WATER FUND	26,043,519.18	339,461.82	522,792.10	25,860,188.90
525	BUILDING PERMITS FUND	1,151,743.82	78,065.80	12,274.56	1,217,535.06
530	CEMETERY FUND	556,935.33	6,662.37	4,069.06	559,528.64
560	FLEET MANAGEMENT FUND	1,576,329.00	-	58,648.00	1,517,681.00
570	GROUP MEDICAL INSURANCE FUND	44,641.37	405,149.23	97,321.99	352,468.61
580	WORKERS COMPENSATION FUND	3,062,230.51	96,560.87	58,510.32	3,100,281.06
590	INSURANCE FUND	1,552,439.86	6,587.41	13,800.14	1,545,227.13
602	REDEVELOPMENT ADMINISTRATIVE FUND	192,028.80	-	11,601.07	180,427.73
603	REDEVELOPMENT REVOLVING FUND	3,791,933.31	-	467,676.28	3,324,257.03
604	REDEVELOPMENT TAX INCREMENT FUND	1,314,166.98	21,468.31	-	1,335,635.29
730	SCHOOL DEBT FUND	13,409,549.91	46,397.18	-	13,455,947.09
740	CARSON CITY TOURISM AUTHORITY	3,325,161.85	37,720.06	47,329.69	3,315,552.22
748	CARSON CITY SCHOOL OPERATING FUND	765,574.42	75,745.31	-	841,319.73
750	STATE OF NEVADA FUND	304,315.81	77,283.15	-	381,598.96
752	RANGE IMPROVEMENT FUND	131.71	-	-	131.71
756	EAGLE VALLEY WATER DISTRICT FUND	100.95	18.97	-	119.92
760	WATER SUB-CONSERVANCY FUND	2,207.59	32,303.73	28,517.31	5,994.01
765	FISH AND GAME FUND	7,118.06	-	-	7,118.06
770	FORFEITURE ACCOUNT	97,896.12	-	-	97,896.12
780	DOWNTOWN NEIGHBORHOOD IMPROV. DIST.	120,164.49	97.00	-	120,261.49
793	CONTROLLER'S TRUST FUND	12,068.36	-	-	12,068.36
850	CARSON CITY OPEB TRUST FUND	2,636,460.06	87,118.62	-	2,723,578.68
<b>TOTAL</b>		<b>\$ 192,488,575.28</b>	<b>\$ 3,446,279.34</b>	<b>\$ 5,177,214.21</b>	<b>\$ 190,757,640.41</b>

<sup>1</sup> Timing difference - awaiting grant reimbursement.



## STAFF REPORT

**Report To:** Board of Supervisors

**Meeting Date:** March 2, 2023

**Staff Contact:** Carol Akers, Purchasing & Contracts Administrator and David Navarro, Parks Operation Superintendent

**Agenda Title:** For Possible Action: Discussion and possible action regarding a proposed increase in purchase authority in the amount of \$5,386.82 to PO 23200198, beyond the previously approved amount of \$127,529, resulting in a new not to exceed amount of \$132,915.82 to purchase a Toro Groundsmaster 5900 for the Carson City Parks, Recreation and Open Space Department ("Parks Department") from Turfstar Western, utilizing a cooperative purchasing agreement through Omnia Partners Public Sector ("OMNIA"). (Carol Akers, Cakers@carson.org and David Navarro, DNavarro@carson.org)

**Staff Summary:** The increase in purchase authority is being requested due to additional fees for setup and delivery not included in the original quote.

**Agenda Action:** Formal Action / Motion

**Time Requested:** Consent

### Proposed Motion

I move to approve the increase in purchase authority as presented.

### Board's Strategic Goal

Efficient Government

### Previous Action

August 18, 2022 (Item 12.B) – the Board of Supervisors approved the purchase of various equipment for the Parks Department, which included the Toro Groundsmaster 5900 for a not to exceed amount of \$127,529.00.

### Background/Issues & Analysis

The increase is being requested due to additional fees for setup and delivery not included in the original quote.

OMNIA Partners Public Sector:

Toro Contract# 2017025 (expires March 31, 2023)

<https://www.omniapartners.com/publicsector/suppliers/toro/contract-documentation>

### Applicable Statute, Code, Policy, Rule or Regulation

NRS 332.195

### Financial Information

**Is there a fiscal impact?** Yes

**If yes, account name/number:** Quality of Life Fund Capital Equipment Account / 2545046 507775

**Is it currently budgeted?** Yes

**Explanation of Fiscal Impact:** 2545046 507775 will be decreased by an additional not to exceed amount of \$5,386.82; the current available budget is \$24,749.26.

**Alternatives**

Do not approve purchase authority increase and/or provide alternative direction to staff.

**Attachments:**

[Turf Star Updated Quote with Delivery & Set up.pdf](#)

[staff report #12B 08-18-22.pdf](#)

[Turf Star Original Quote.pdf](#)

**Board Action Taken:**

Motion: \_\_\_\_\_

- 1) \_\_\_\_\_
- 2) \_\_\_\_\_

Aye/Nay

\_\_\_\_\_  
\_\_\_\_\_  
\_\_\_\_\_  
\_\_\_\_\_  
\_\_\_\_\_

\_\_\_\_\_  
(Vote Recorded By)





## Quotation for Carson City Parks Maint

Date: January 25, 2023

Quote No:635839-00

Prepared For: Paul Griffiths

Carson City Parks Maint  
3303 Butti Way Bldg 9  
Carson City, NV 89706

Quote No: 635839-00

iQuote No: 104403

Sales Person: Don Kittilsen  
don.kittilsen@turfstar.com  
(916) 709-7104

*National IPA Pricing: Contract 2017025, IPA Membership required.  
Carson City Parks National IPA/Omnia Partners membership number is NIPA3257*

### Summary

Configuration Name	Qty	Unit Price	Sub Total	Sales Tax	Total
010-GM5900 T4 Final	1	\$132,915.82	\$132,915.82	\$0.00	\$132,915.82
<b>Totals:</b>			\$132,915.82	\$0.00	\$132,915.82



Date: January 25, 2023

### Quotation for Carson City Parks Maint

Quote No:635839-00

## Configuration Product Details 010-GM5900 T4 Final

Model	Product Description	Qty	Unit Price	Extended	Sales Tax	Total
31698	GM5900 T4 Final	1	\$122,984.16	\$122,984.16	\$0.00	\$122,984.16
138-3002	POWER-HARNESS, KIT (GM59 00)	1	\$89.47	\$89.47	\$0.00	\$89.47
03247	Operating Cooling Fan	1	\$265.98	\$265.98	\$0.00	\$265.98
03248	Switch Panel, Universal Sunshade	1	\$234.78	\$234.78	\$0.00	\$234.78
31604	Leaf Mulching Kit	1	\$2,571.66	\$2,571.66	\$0.00	\$2,571.66
132-1391	BLADE SERVICE PACK, ATOMIC 20.00 IN	2	\$302.23	\$604.46	\$0.00	\$604.46
131-6691	SEAT COVER, LARGE	1	\$45.29	\$45.29	\$0.00	\$45.29
30669	Universal Sunshade White	1	\$733.20	\$733.20	\$0.00	\$733.20
FSD1	Setup	1	\$2,693.41	\$2,693.41	\$0.00	\$2,693.41
FSD2	Delivery	1	\$2,693.41	\$2,693.41	\$0.00	\$2,693.41
<b>Totals:</b>						<b>\$132,915.82</b>



## STAFF REPORT

**Report To:** Board of Supervisors **Meeting Date:** August 18, 2022

**Staff Contact:** Carol Akers, Purchasing & Contracts Administrator and David Navarro, Parks Operation Superintendent

**Agenda Title:** For Possible Action: Discussion and possible action regarding authorization to purchase various equipment for the Carson City Department of Parks, Recreation and Open Space ("Parks Department"), utilizing cooperative purchasing agreements available through OMNIA Partners Public Sector ("OMNIA") and Sourcewell, for a total not to exceed amount of \$400,885.86. (Carol Akers, cakers@carson.org and David Navarro, dnavarro@carson.org)

Staff Summary: Approval of this item would authorize the purchase of various equipment for the Parks Department, as approved by the Capital Improvement Program ("CIP") for Fiscal Year ("FY") 2023. The purchase amounts with vendors exceed \$50,000 and therefore requires approval by the Board of Supervisors.

**Agenda Action:** Formal Action / Motion **Time Requested:** Consent

---

### Proposed Motion

I move to approve the purchase authority as requested.

### Board's Strategic Goal

Efficient Government

### Previous Action

May 19, 2022 – The Board of Supervisors approved the final budget for FY 2023, including the CIP.

### Background/Issues & Analysis

The Parks Department has been working on updating equipment fleet that are aging, singular use and more costly to repair and maintain. Strategically updating aging equipment as it depreciates, and adding new equipment with versatility to perform multiple tasks, are priorities for the Parks Department. The equipment intended to be purchased represents essential and versatile components of the Parks Department's fleet. Current equipment that is slated to be replaced will either be salvaged for parts for other equipment or sent to auction.

The Parks Department has over 8,000 acres of Open Space, 100+ acres of turf to mow, two large parks (Mills Park and Fuji Park) and three sport complexes that regularly have activities on the schedule starting in February and ending in November; having versatile and high efficiency equipment is a must. If the City does not have this type of equipment in its fleet, the overall staff hours and repair cost will significantly increase while the City's level of services will decrease.

Approval of this request will authorize the purchase of:

1. Toro Groundsmaster 5900 mower - This mower would be new to the current fleet of mowers. The GM5900 is a high efficiency yielding mower allowing staff to mow large areas in a shorter amount of time.
2. SmithCo Sand-Star Electric infield drag - This piece of equipment would replace an aging infield drag and also provide the department with its first piece of 48volt electrical equipment.
3. SmithCo Sweep Star 60 - This piece of equipment replaces the current Sweep Star that has been in service for over 15 years.
- 4 & 5. (2) Turfco Edge-R-Rite II - Replaces current piece of equipment that has been in service for 16+ years.
6. Kubota KX033-4R3A mini excavator - This is a new piece of equipment for the fleet that has many versatile uses for the Parks Department. It will also come with a bulldozing blade and three buckets for digging and grading.
- 7 & 8. (2) Kubota RTV X900 - These Kubota RTV's will be replacing existing vehicles in the fleet that have exceeded their useful life and have been in service for 16+ years.
9. Bobcat UW53 Tool Kat - This is a new addition to the equipment fleet that provides many different uses and attachments for completing different tasks from working on a trail, installing fence post or moving material around. This piece of equipment will also come with the following quick attachment: box blade, brush mower, bucket, landplane, V-blade snow plow and auger.

Please refer to the attached spreadsheet for all the equipment information. These proposed purchases were approved as part of the FY 2023 CIP. All quotes have been verified and all vendors have confirmed they will honor quotes as provided.

Contracts being utilized:

OMNIA Partners Public Sector:

Toro Contract# 2017025 (expires March 31, 2023)

<https://www.omniapartners.com/publicsector/suppliers/toro/contract-documentation>

Sourcewell:

1. Deere and Company Contract #031121-DAC (expires April 30, 2025)

Belcorp Ag, LLC, Ahern Rentals, Inc. and Nevada Power Products are authorized dealer

<https://www.sourcewell-mn.gov/cooperative-purchasing/031121-dac>

2. Kubota Contract# 031121-KBA (expires April 30, 2025)

<https://www.sourcewell-mn.gov/cooperative-purchasing/031121-kba#tab-contract-documents>

3. Bobcat/Doosan/Clark Equip. Compact Construction Equipment Contract #040319-CEC (expires May 31, 2023)

<https://www.sourcewell-mn.gov/cooperative-purchasing/040319-cec#tab-contract-documents>

#### **Applicable Statute, Code, Policy, Rule or Regulation**

NRS 332.195

#### **Financial Information**

Is there a fiscal impact? Yes

If yes, account name/number: Capital Projects Fund Parks Equipment Replacement Account / 2105050 506515

Quality of Life Fund Park Maintenance Equipment Account / 2545012 507775

Quality of Life Fund Capital Equipment Account / 2545046 507775

Quality of Life Fund Open Space Equipment Account / 2545047 507775

Is it currently budgeted? Yes

**Explanation of Fiscal Impact:** 2105050 506515 will be decreased by a not to exceed amount of \$34,771.58; the approved budget is \$37,845.

2545012 507775 will be decreased by a not to exceed amount of \$30,508.75; the approved budget is \$30,510.

2545046 507775 will be decreased by a not to exceed amount of \$257,447.74; the approved budget is \$257,086.

2545047 507775 will be decreased by a not to exceed amount of \$78,157.79; the approved budget is \$95,331.00.

If approved, the overage of \$361.74 in the Quality of Life Capital account 2545046-507775 will come from the undesignated account (current amount available from FY 22 and FY 23 is \$195,955).

**Alternatives**

Do not approve the purchase authority and/or provide alternative direction to staff.

**Attachments:**

PARKS CIP FY 23 EQUIPMENT LISTING.pdf

FY23 CIP Equipment Quotes.pdf

**Board Action Taken:**

Motion: Approved w/ reduced amt.  
Return for remainder  
of funding at a future  
date.

- 1) SJ
- 2) MW

Aye/Nay

4-1-0

↑

SG

TD

(Vote Recorded By)



Date: April 28, 2022

### Quotation for Carson City Parks Maint

Quote No:631520-00

Prepared For: Paul Griffitts	Quote No: 631520-00
Carson City Parks Maint	iQuote No: 104403
3303 Butti Way Bldg 9	Sales Person: Don Kittilsen
Carson City, NV 89706	don.kittilsen@turfstar.com (916) 709-7104

*National IPA Pricing: Contract 2017025, IPA Membership required.  
Carson City Parks National IPA/Omnia Partners membership number is NIPA3257  
Any unforeseen Toro price increase prior to delivery will be added*

## Summary

Configuration Name	Qty	Unit Price	Sub Total	Sales Tax	Total
010-GM5900 T4 Final	1	\$127,529.00	\$127,529.00	\$0.00	\$127,529.00
<b>Totals:</b>			<b>\$127,529.00</b>	<b>\$0.00</b>	<b>\$127,529.00</b>

**PARKS MOWER (Reference ID#1)**

FY23 CIP  
BOS Approved 8-18-22  
2545046-507775

Handwritten notes in the bottom right corner, possibly including a date and some illegible text.



Date: April 28, 2022

## Quotation for Carson City Parks Maint

Quote No:631520-00

### Configuration Product Details 010-GM5900 T4 Final

Model	Product Description	Qty	Unit Price	Extended	Sales Tax	Total
31698	GM5900 T4 Final	1	\$122,984.16	\$122,984.16	\$0.00	\$122,984.16
138-3002	POWER-HARNESS, KIT (GM59 00)	1	\$89.47	\$89.47	\$0.00	\$89.47
03247	Operating Cooling Fan	1	\$265.98	\$265.98	\$0.00	\$265.98
03248	Switch Panel, Universal Sunshade	1	\$234.78	\$234.78	\$0.00	\$234.78
31604	Leaf Mulching Kit	1	\$2,571.66	\$2,571.66	\$0.00	\$2,571.66
132-1391	BLADE SERVICE PACK, ATOM IC 20.00 IN	2	\$302.23	\$604.46	\$0.00	\$604.46
131-6691	SEAT COVER, LARGE	1	\$45.29	\$45.29	\$0.00	\$45.29
30669	Universal Sunshade White	1	\$733.20	\$733.20	\$0.00	\$733.20
<b>Totals:</b>						<b>\$127,529.00</b>







## STAFF REPORT

**Report To:** Board of Supervisors                      **Meeting Date:** March 2, 2023  
**Staff Contact:** Carol Akers, Purchasing & Contracts Administrator and Sheriff Ken Furlong

**Agenda Title:** For Possible Action: Discussion and possible action regarding a proposed increase in purchase authority in the amount of \$7,061.62, beyond the previously approved amount of \$80,226.48, resulting in a new not to exceed amount of \$87,288.10, to purchase various kitchen appliances for the Carson City Sheriff's Office Jail ("Jail") utilizing joinder contract (#R180202) between Region 4 Education Service Center, Houston, Texas and National Restaurant Supply. (Carol Akers, cakers@carson.org and Sheriff Ken Furlong, kfurlong@carson.org)

Staff Summary: The increase in purchase authority is being requested as the result of changing the Jail convection steamer from a gas to electric appliance.

**Agenda Action:** Formal Action / Motion                      **Time Requested:** Consent

---

### Proposed Motion

I move to approve the increase in purchase authority as presented.

### Board's Strategic Goal

Efficient Government

### Previous Action

December 15, 2022 (Item 13.A): The Board of Supervisors approved the purchase authority for various kitchen appliances for the Jail for a not to exceed amount of \$80,226.48.

### Background/Issues & Analysis

The increase is being requested due to changing the convection steamer from gas to electric because the connection line is electric.

The vendor has confirmed the updated quote is still valid.

Joinder contract being utilized:

Region 4 Education Service Center, Houston, Texas and National Restaurant Supply

Contract #R180202, expires May 31, 2023.

<https://www.omniapartners.com/publicsector/suppliers/national-restaurant-supply-co-inc/contract-documentation#c36121>

### Applicable Statute, Code, Policy, Rule or Regulation

NRS 332.195

### Financial Information

**Is there a fiscal impact? Yes**

**If yes, account name/number:** Capital Projects Fund Sheriffs Facility Upgrade Account / 2102020-507712

**Is it currently budgeted? Yes**

**Explanation of Fiscal Impact:** Account 2102020-507712 will be decreased by an additional not to exceed amount of \$7,061.62; the approved capital budget for all the appliances is \$102,704.

**Alternatives**

Do not approve the purchase authority increase and/or provide alternative direction to staff.

**Attachments:**

[National Restaurant Supply\\_UPDATED\\_Quote.pdf](#)

[13A.pdf](#)

[National Restataurant Supply\\_Original Quote.pdf](#)

**Board Action Taken:**

Motion: \_\_\_\_\_

1) \_\_\_\_\_

2) \_\_\_\_\_

Aye/Nay

\_\_\_\_\_

\_\_\_\_\_

\_\_\_\_\_

\_\_\_\_\_

\_\_\_\_\_

\_\_\_\_\_  
(Vote Recorded By)

**To:**  
 Carson City Jail  
 Carol Akers  
 (775) 283-7362 (Contact)



**Project:**  
 City of Carson-Jail

**From:**  
 National Restaurant Supply - AZ  
 Matt Weldon  
 mattw@nrsupply.com  
 7125 Industrial Avenue  
 El Paso, TX 79915  
 (602) 225-2200  
 480-352-0049 (Contact)



Project Code: DT1248

Job Reference Number: 550

**OMNIA PARTNERS CONTRACT #R180202, MUST BE ON THE PURCHASE ORDER**

Item	Qty	Description	Sell	Sell Total
1	1 ea	<b>CONVECTION OVEN, GAS</b>  Vulcan Model No. VC55GD Convection Oven, gas, double-deck, standard depth, solid state controls, electronic spark ignition, 5-hour timer with digital display enhancement, 150° to 500°F temperature range, (5) oven racks per deck, independently operated removable doors with windows, porcelain on steel interior, interior light, stainless steel front, top, & sides, 8" stainless steel legs, (2) 1/2 HP blower motors, (2) 50,000 BTU, NSF, CSA Star, CSA Flame, ENERGY STAR®	\$10,294.74	\$10,294.74
	1 ea	1 year limited parts & labor warranty, standard		
	1 ea	Natural gas 4802' elevation		
	1 ea	(2) 120v/60/1-ph, 15.4 amps total, (2) cords with plugs, standard		
	1 ea	Gas manifold piping included with stacking kit to provide single point gas connection		
	1 st	Casters, set of (4) in lieu of standard legs	\$110.65	\$110.65
<b>NOTE: SECURITY PACKAGE NOT AVAILABLE FOR THIS MODEL.</b>				
			<b>ITEM TOTAL:</b>	<b>\$10,405.39</b>
±	<del>1 ea</del>	<del><b>CONVECTION OVEN, GAS</b></del>  <del>Vulcan Model No. VC44GD                      Convection Oven, gas, double-deck, standard depth, solid state controls, electronic spark igniters, 60-minute timer, (5) nickel-plated racks per oven, 8" high legs, stainless steel front, top &amp; sides, stainless steel doors with windows, (2) 50,000 BTU, NSF, CSA Star, CSA Flame, ENERGY STAR®</del>	<del>\$19,501.58</del>	<del>&lt;Alternate&gt;</del>
	<del>1 ea</del>	<del>1 year limited parts &amp; labor warranty, standard</del>		<del>&lt;Alternate&gt;</del>

B 0.12 increase

Item	Qty	Description	Sell	Sell Total
		<del>1 ea Gas type to be specified</del>		<Alternate>
		<del>1 ea (2) 120v/60/1 ph, 15.4 amps total, (2) cords with plugs, standard</del>		<Alternate>
		<del>1 ea Gas manifold piping included with stacking kit to provide single point gas connection</del>		<Alternate>
		<del>1 st Casters, set of (4) in lieu of standard legs</del>	\$110.65	<Alternate>
		<del>2 ea Prison Security Packages: exterior Security screws, perforated stainless steel hinged control covers with locking for pad locks, oven door locks for pad lock (locks not included), top, bottom &amp; rear screen enclosures</del>	\$2,261.61	<Alternate>
		<del>NOTE: ALTERNATE IF SECURITY PACKAGE IS NEEDED.</del>		<Alternate>
			<b>ITEM TOTAL:</b>	<b>&lt;Alternate&gt;</b>
				<b>\$24,135.45</b>
2	1 kt	<b>BLUE HOSE GAS CONNECTOR KIT</b> Dormont Manufacturing Model No. 1675KIT48 Packed 1 kt Dormont Blue Hose™ Moveable Gas Connector Kit, 3/4" inside dia., 48" long, covered with stainless steel braid, coated with blue antimicrobial PVC, (1) SnapFast® QD, (1) full port valve, (2) 90° elbows, coiled restraining cable with hardware, 180,000 BTU/hr minimum flow capacity, limited lifetime warranty	\$195.00	\$195.00
				
			<b>ITEM TOTAL:</b>	<b>\$195.00</b>
3	1 ea	<b>CONVECTION STEAMER, ELECTRIC</b> Vulcan Model No. C24ET10 ET Series Convection Steamer, electric, 2 compartments, 24" cabinet base, (10) 12" x 20" x 2-1/2" deep total pan capacity, dual high output stainless steel steam generators with Smart Drain system & Powerflush, individual professional controls with 60 minute timer, buzzer for each compartment, & constant steam feature, staged water fill, split water line, single drain connection, stainless steel interior & exterior, dual delime ports, leveling feet, 30kW, UL EPH, cULus Listed, ENERGY STAR®  1 ea 1 year limited parts & labor warranty, standard 1 ea Professional control package includes independent control for each cooking compartment with 60-minute timer, buzzer, constant steam mode, cook & ready lights & power switch. Automatic drain at power down 1 ea 208v/50/60/3-ph, 94.0 amps, 30 kW, direct wire, standard	\$24,110.22	\$24,110.22
				
			<b>ITEM TOTAL:</b>	<b>\$24,110.22</b>
4	1 ea	<b>KETTLE, ELECTRIC, TILTING</b> Vulcan Model No. K40ELT Tilting Kettle, Electric, 40-gallon true working capacity, 2/3 jacketed, 316 series stainless steel liner with ellipsoidal bottom, manual tilt, faucet bracket on tilting console, stainless steel construction, tri-leg base, cULus, UL EPH, ANSI/NSF 4, ASME  1 ea 1 year limited parts & labor warranty, standard	\$28,030.21	\$28,030.21
				

*\$ 7,061.50 increase*

Item	Qty	Description	Sell	Sell Total
	1 ea	NOTE: This unit includes: embossed gallon/liter markings, 316 stainless steel liner & heavy bar rim standard		
	1 ea	208v/60/3-ph, 18kW, 50.0 amps, direct wired, standard		
	1 ea	SGLTS 18NZLJ SINGLE Pantry Deck Mount Faucet, 18" double jointed swivel spout, includes 4" & 12" riser, NSF & Lead Reduction Compliant (Note: water connection required)	\$429.84	\$429.84
	1 ea	TK-PPS K Series Tilting Kettle Security Package, includes security fasteners & tack welds, controls protected by lockable cover, stainless steel screen on flue (gas only)	\$2,851.77	\$2,851.77
			<b>ITEM TOTAL:</b>	<b>\$31,311.82</b>
5	1 ea	<b>RANGE, 48", 2 BURNERS, 36" GRIDDLE</b> Vulcan Model No. 48C-2B36G Endurance™ Restaurant Range, gas, 48", (2) 30,000 BTU burners with lift-off burner heads, (1) 36" griddle, 7/8" thick plate, manual controls, 4"W front grease trough, convection oven, stainless steel front, sides, backriser & lift-off high shelf, fully MIG welded chassis, 6" adjustable legs, 155,000 BTU, CSA Flame, CSA Star, NSF	\$12,964.31	\$12,964.31
	1 ea	1 year limited parts & labor warranty, standard		
	1 ea	Natural gas 4802' elevation		
	1 ea	115v/60/1-ph, cord & plug, standard		
	1 ea	Griddle on right side, standard		
	1 ea	Oven base on right side, standard		
	1 ea	Stainless steel backriser & lift-off high shelf, standard		
	2 st	CASTERS-RR4 Casters, 5" (set of 4) (2 with locks) (quantity of 2 required)	\$461.17	\$922.34
			<b>ITEM TOTAL:</b>	<b>\$13,886.65</b>
6	1 kt	<b>BLUE HOSE GAS CONNECTOR KIT</b> Dormont Manufacturing Model No. 16100KIT48 Packed 1 kt Dormont Blue Hose™ Moveable Gas Connector Kit, 1" inside dia., 48" long, covered with stainless steel braid, coated with blue antimicrobial PVC, (1) SnapFast® QD, (1) full port valve, (2) 90° elbows, coiled restraining cable with hardware, 334,000 BTU/hr minimum flow capacity, limited lifetime warranty	\$301.80	\$301.80
			<b>ITEM TOTAL:</b>	<b>\$301.80</b>
7	1 ea	<b>RANGE, 36", 6 OPEN BURNERS</b> Vulcan Model No. 36C-6BN Endurance™ Restaurant Range, natural gas, 36", (6) 30,000 BTU burners, lift-off burner heads, convection oven, stainless steel front, sides, backriser & lift-off high shelf, fully MIG welded chassis, 6" adjustable legs, 215,000 BTU, CSA, NSF	\$6,421.05	\$6,421.05
	1 ea	1 year limited parts & labor warranty, standard		
	1 ea	115v/60/1-ph, cord & plug, standard		
	1 ea	Stainless steel backriser & lift-off high shelf, standard		

Item	Qty	Description	Sell	Sell Total
	1 st	CASTERS-RR4 Casters, 5" (set of 4) (2 with locks)	\$461.17	\$461.17
			<b>ITEM TOTAL:</b>	<b>\$6,882.22</b>
8	1 kt	<b>BLUE HOSE GAS CONNECTOR KIT</b> Dormont Manufacturing Model No. 1675KIT48 Packed 1 kt Dormont Blue Hose™ Moveable Gas Connector Kit, 3/4" inside dia., 48" long, covered with stainless steel braid, coated with blue antimicrobial PVC, (1) SnapFast® QD, (1) full port valve, (2) 90° elbows, coiled restraining cable with hardware, 180,000 BTU/hr minimum flow capacity, limited lifetime warranty	\$195.00	\$195.00
			<b>ITEM TOTAL:</b>	<b>\$195.00</b>
			Total	\$87,288.10



**LOADING DOCK REQUIRED, FREE FREIGHT**

**QUOTE IS GOOD FOR 30 DAYS FROM ABOVE DATE**

*total increase of \$7,001.62*

*All taxes, freight, delivery installation, plumbing and electrical are extra unless specified in this quote.*

*All final connections are by others. ~Prices are FOB factory or our warehouse unless specified.*

*All warranties are FACTORY warranties.*

*Any cancellations or returns of special orders or not stock items will be charged a restock charge of 30% plus freight.*

*If product is drop shipped to a customer location; customer is responsible for receiving equipment and any freight claims when applicable.*

**THANK YOU FOR THE OPPORTUNITY TO SERVE YOU!!**

Acceptance: \_\_\_\_\_ Date: \_\_\_\_\_

Printed Name: \_\_\_\_\_

Project Grand Total: \$87,288.10





# STAFF REPORT

**Report To:** Board of Supervisors **Meeting Date:** December 15, 2022

**Staff Contact:** Carol Akers, Purchasing & Contracts Administrator and Sheriff Ken Furlong

**Agenda Title:** For Possible Action: Discussion and possible action regarding authorization to purchase various kitchen appliances for the Carson City Sheriff's Office Jail ("Jail") for a not to exceed amount of \$80,226.48 utilizing joinder contract (#R180202) between Region 4 Education Service Center, Houston, Texas and National Restaurant Supply. (Carol Akers, cakers@carson.org and Sheriff Ken Furlong, kfurlong@carson.org)

Staff Summary: Approval of this item would authorize the purchase of various kitchen equipment for the Jail, as approved in the Capital Improvement Program ("CIP") for Fiscal Year ("FY") 2023. The amount of the purchase with this vendor will exceed \$50,000 and therefore requires approval by the Board of Supervisors ("Board").

**Agenda Action:** Formal Action / Motion **Time Requested:** Consent

**Proposed Motion**

I move to approve the purchase authority as presented.

**Board's Strategic Goal**

Efficient Government

**Previous Action**

May 19, 2022 (Item 17.A): The Board approved the Final Budget for FY 2023, including the CIP.

**Background/Issues & Analysis**

The current appliances in the Jail are approximately 10-20 years old. The appliances are constantly breaking down, causing the kitchen to call appliance repair personnel into the facility to repair the various appliances and reducing the efficiency of the kitchen. Replacement of the appliances was approved in the FY 2023 CIP.

Quotes were solicited from 3 commercial kitchen suppliers.

National Restaurant Supply	\$80,226.48
RestaurantSupply.com	\$81,042.72
Cook's Direct	\$81,999.19

National Restaurant Supply confirmed quote pricing valid through 12/23/2022.

Joinder contract being utilized:

Region 4 Education Service Center, Houston, Texas and National Restaurant Supply

Contract #R180202, expires February 28, 2023.

<https://www.omniapartners.com/publicsector/suppliers/national-restaurant-supply-co-inc/contract-documentation#c36121>



**Applicable Statute, Code, Policy, Rule or Regulation**

NRS 332.195

**Financial Information**

**Is there a fiscal impact?** Yes

**If yes, account name/number:** Capital Projects Fund Sheriffs Facility Upgrade Account / 2102020-507712

**Is it currently budgeted?** Yes

**Explanation of Fiscal Impact:** Account 2102020-507712 will be decreased by an amount not to exceed \$80,226.48; the approved capital budget for the appliances is \$102,704.

**Alternatives**

Do not approve the purchase authority and/or provide alternative direction to staff.

**Attachments:**

National Restataurant Supply\_Quote 3 -City\_of\_Carson\_Jail.pdf

**Board Action Taken:**

Motion: Approve

- 1) SG
- 2) MW

Aye/Nay

\_\_\_\_\_

\_\_\_\_\_

\_\_\_\_\_

\_\_\_\_\_

\_\_\_\_\_

5/10/10

AR

(Vote Recorded By)



# Quote

11/11/2022

**To:**  
 Carson City Jail  
 Carol Akers  
 (775) 283-7362 (Contact)



**Project:**  
 City of Carson-Jail

**From:**  
 National Restaurant Supply - AZ  
 Matt Weldon  
 mattw@nrsupply.com  
 7125 Industrial Avenue  
 El Paso, TX 79915  
 (602) 225-2200  
 480-352-0049 (Contact)



Project Code: DT1248

Job Reference Number: 550

**OMNIA PARTNERS CONTRACT #R180202, MUST BE ON THE PURCHASE ORDER**

Item	Qty	Description	Sell	Sell Total
1	1 ea	<b>CONVECTION OVEN, GAS</b>  Vulcan Model No. VC55GD Convection Oven, gas, double-deck, standard depth, solid state controls, electronic spark ignition, 5-hour timer with digital display enhancement, 150° to 500°F temperature range, (5) oven racks per deck, independently operated removable doors with windows, porcelain on steel interior, interior light, stainless steel front, top, & sides, 8" stainless steel legs, (2) 1/2 HP blower motors, (2) 50,000 BTU, NSF, CSA Star, CSA Flame, ENERGY STAR® 1 ea 1 year limited parts & labor warranty, standard 1 ea Natural gas 4802' elevation 1 ea (2) 120v/60/1-ph, 15.4 amps total, (2) cords with plugs, standard 1 ea Gas manifold piping included with stacking kit to provide single point gas connection 1 st Casters, set of (4) in lieu of standard legs	\$10,294.74	\$10,294.74
			<b>ITEM TOTAL:</b>	<b>\$10,405.27</b>
1	1 kt	<b>BLUE HOSE GAS CONNECTOR KIT</b>  Dormont Manufacturing Model No. 1675KIT48 Packed 1 kt Dormont Blue Hose™ Moveable Gas Connector Kit, 3/4" inside dia., 48" long, covered with stainless steel braid, coated with blue antimicrobial PVC, (1) SnapFast® QD, (1) full port valve, (2) 90° elbows, coiled restraining cable with hardware, 180,000 BTU/hr minimum flow capacity, limited lifetime warranty	\$195.00	\$195.00
			<b>ITEM TOTAL:</b>	<b>\$195.00</b>
2	1 ea	<b>CONVECTION STEAMER, DIRECT STEAM</b>	\$17,048.72	\$17,048.72

Item	Qty	Description	Sell	Sell Total
		Vulcan Model No. C24DA6 Convection Steamer, Direct Steam (Potable/Clean Steam), 2 compartments on 24" cabinet base, (6) 12" x 20" x 2-1/2" deep total pan capacity, manual control with 60-minute timer with buzzer each compartment, single water line for drain tempering, stainless steel interior, exterior, frame & flanged feet, 2.4 BHP		
	1 ea	1 year limited parts & labor warranty, standard		
		<b>NOTE: MODEL REQUESTED IS DIRECT STEAM &amp; REQUIRES STEAM HOOK UP. CONFIRM LOCATION HAS BOILER ON SITE.</b>		
			<b>ITEM TOTAL:</b>	<b>\$17,048.72</b>
3	1 ea	<b>KETTLE, ELECTRIC, TILTING</b> Vulcan Model No. K40ELT Tilting Kettle, Electric, 40-gallon true working capacity, 2/3 jacketed, 316 series stainless steel liner with ellipsoidal bottom, manual tilt, faucet bracket on tilting console, stainless steel construction, tri-leg base, cULus, UL EPH, ANSI/NSF 4, ASME	\$28,030.21	\$28,030.21
	1 ea	1 year limited parts & labor warranty, standard		
	1 ea	NOTE: This unit includes: embossed gallon/liter markings, 316 stainless steel liner & heavy bar rim standard		
	1 ea	208v/60/3-ph, 18kW, 50.0 amps, direct wired, standard		
	1 ea	SGLTS 18NZLJ SINGLE Pantry Deck Mount Faucet, 18" double jointed swivel spout, includes 4" & 12" riser, NSF & Lead Reduction Compliant (Note: water connection required)	\$429.84	\$429.84
	1 ea	TK-PPS K Series Tilting Kettle Security Package, includes security fasteners & tack welds, controls protected by lockable cover, stainless steel screen on flue (gas only)	\$2,851.77	\$2,851.77
			<b>ITEM TOTAL:</b>	<b>\$31,311.82</b>
4	1 ea	<b>RANGE, 48", 2 BURNERS, 36" GRIDDLE</b> Vulcan Model No. 48C-2B36G Endurance™ Restaurant Range, gas, 48", (2) 30,000 BTU burners with lift-off burner heads, (1) 36" griddle, 7/8" thick plate, manual controls, 4"W front grease trough, convection oven, stainless steel front, sides, backriser & lift-off high shelf, fully MIG welded chassis, 6" adjustable legs, 155,000 BTU, CSA Flame, CSA Star, NSF	\$12,964.31	\$12,964.31
	1 ea	1 year limited parts & labor warranty, standard		
	1 ea	Natural gas 4802' elevation		
	1 ea	115v/60/1-ph, cord & plug, standard		
	1 ea	Griddle on right side, standard		
	1 ea	Oven base on right side, standard		
	1 ea	Stainless steel backriser & lift-off high shelf, standard		
	2 st	CASTERS-RR4 Casters, 5" (set of 4) (2 with locks) (quantity of 2 required)	\$461.17	\$922.34
			<b>ITEM TOTAL:</b>	<b>\$13,886.65</b>

Item	Qty	Description	Sell	Sell Total
4	1 kt	<b>BLUE HOSE GAS CONNECTOR KIT</b>  Dormont Manufacturing Model No. 16100KIT48 Packed 1 kt Dormont Blue Hose™ Moveable Gas Connector Kit, 1" inside dia., 48" long, covered with stainless steel braid, coated with blue antimicrobial PVC, (1) SnapFast® QD, (1) full port valve, (2) 90° elbows, coiled restraining cable with hardware, 334,000 BTU/hr minimum flow capacity, limited lifetime warranty	\$301.80	\$301.80
			<b>ITEM TOTAL:</b>	<b>\$301.80</b>
5	1 ea	<b>RANGE, 36", 6 OPEN BURNERS</b>  Vulcan Model No. 36C-6BN Endurance™ Restaurant Range, natural gas, 36", (6) 30,000 BTU burners, lift-off burner heads, convection oven, stainless steel front, sides, backriser & lift-off high shelf, fully MIG welded chassis, 6" adjustable legs, 215,000 BTU, CSA, NSF 1 ea 1 year limited parts & labor warranty, standard 1 ea 115v/60/1-ph, cord & plug, standard 1 ea Stainless steel backriser & lift-off high shelf, standard 1 st CASTERS-RR4 Casters, 5" (set of 4) (2 with locks) <b>NOTE: QUOTING ELITE PLATINUM PRICE</b>	\$6,421.05	\$6,421.05
			<b>ITEM TOTAL:</b>	<b>\$6,882.22</b>
5	1 kt	<b>BLUE HOSE GAS CONNECTOR KIT</b>  Dormont Manufacturing Model No. 1675KIT48 Packed 1 kt Dormont Blue Hose™ Moveable Gas Connector Kit, 3/4" inside dia., 48" long, covered with stainless steel braid, coated with blue antimicrobial PVC, (1) SnapFast® QD, (1) full port valve, (2) 90° elbows, coiled restraining cable with hardware, 180,000 BTU/hr minimum flow capacity, limited lifetime warranty	\$195.00	\$195.00
			<b>ITEM TOTAL:</b>	<b>\$195.00</b>
			Total	\$80,226.48

**LOADING DOCK REQUIRED, FREE FREIGHT**

**QUOTE IS GOOD FOR 30 DAYS FROM ABOVE DATE**

*All taxes, freight, delivery installation, plumbing and electrical are extra unless specified in this quote.*

*All final connections are by others. ~Prices are FOB factory or our warehouse unless specified.*

*All warranties are FACTORY warranties.*

*Any cancellations or returns of special orders or not stock items will be charged a restock charge of 30% plus freight.*

*If product is drop shipped to a customer location; customer is responsible for receiving equipment and any freight claims when applicable.*

***THANK YOU FOR THE OPPORTUNITY TO SERVE YOU!!***

Acceptance: \_\_\_\_\_ Date: \_\_\_\_\_

Printed Name: \_\_\_\_\_

Project Grand Total: \$80,226.48

## OVENS

**VULCAN****VC55G SERIES  
DOUBLE DECK GAS CONVECTION OVEN  
WITH REMOVABLE DOORS**

**Model VC55GD**  
Shown with optional casters

**SPECIFICATIONS**

Double section gas convection oven, Vulcan Model No. VC55GD. Stainless steel front, sides, top and legs. Independently operated stainless steel doors with double pane windows. Non-sag insulation applied to the top, rear, sides, bottom and doors. Porcelain enamel on steel oven interiors measures 29"w x 22<sup>1</sup>/<sub>8</sub>"d x 20"h. One interior oven light per section. Five nickel plated oven racks per section measure 28<sup>3</sup>/<sub>4</sub>" x 20<sup>1</sup>/<sub>2</sub>" with grab-and-go front cut out. Eleven position nickel plated rack guides with positive rack stops. One 50,000 BTU/hr. burner per section. 100,000 total BTU/hr. Electronic spark igniters. Furnished with a two speed 1/2 H.P. oven blower-motor per section. Oven cool switch for rapid cool down. 120 volt, 60 Hz, 1 ph power supply required. 6' cord and plug. 7.7 amps total draw per section.

**Exterior Dimensions:**

40"w x 40"d (includes motor & door handles) 37<sup>1</sup>/<sub>4</sub>"d (includes motor only) x 68<sup>3</sup>/<sub>4</sub>"h on 8" legs.

CSA design certified. NSF listed.

**SPECIFY TYPE OF GAS WHEN ORDERING.**  
**SPECIFY ALTITUDE WHEN ABOVE 2,000 FT.**

- VC55GD** Solid state temperature dial controls adjust from 150° to 500°F with digital display enhancement. 5-hour timer with audible alarm.

**STANDARD FEATURES**

- Independently operated lift-off stainless steel doors with double pane windows.
- On-board diagnostics for easy servicing
- Stainless steel front, sides and top.
- Five nickel plated grab-and-go oven racks with eleven rack positions.
- Painted legs.
- 5-hour timer with digital display enhancement.
- Cool-to-the-touch handles.
- 50,000 BTU/hr. burner.
- Electronic spark igniter.
- 1/2 H.P. two speed oven blower-motor. 120/60/1 with 6' cord and plug. 7.7 amps total draw.
- Oven cool switch for rapid cool down.
- Porcelain enamel on steel oven interior.
- 3/4" rear gas connection with combination gas valve / pressure regulator and safety solenoid system.
- One year limited parts and labor warranty.
- Three year limited warranty on doors.

**OPTIONS**

- Stainless steel legs.
- Casters.
- Second year extended limited parts and labor warranty.

**ACCESSORIES**

- Extra oven rack(s).
- Rack hanger.
- Stainless steel drip pan.
- Flexible gas hose with quick disconnect and restraining device. Consult price book for available sizes.
- Down draft flue diverter for direct vent connection.

**VULCAN**

a division of ITW Food Equipment Group LLC

P.O. Box 696 ■ Louisville, KY 40201 ■ Toll-free: 1-800-814-2028 ■ Local: 502-778-2791 ■ Quote & Order Fax: 1-800-444-0602

O V E N S



**VC55G SERIES**  
**DOUBLE DECK GAS CONVECTION OVEN**  
**WITH REMOVABLE DOORS**

**INSTALLATION INSTRUCTIONS**

1. A combination gas valve/pressure regulator and safety solenoid system is included in this unit. Natural gas is 5.0" W.C., Propane gas is 10.0" W.C.
2. An adequate ventilation system is required for commercial cooking equipment. Information may be obtained by writing to the National Fire Protection Association, Batterymarch Park, Quincy, MA 02289. When writing, refer to NFPA No. 96.
3. These units are manufactured for installation in accordance with ANSZ223.1 (latest edition), National Fuel Gas Code. Copies may be obtained from American Gas Association Inc.,

Accredited Standards Committee Z223, 400 N. Capitol St. NW, Washington, DC 20001 or the Secretary Standards Council, NFPA, 1 Batterymarch Park, Quincy, MA 02169-7471.

4. Clearances:
 

	Combustible	Non-combustible
Rear	0"	0"
Right Side	2"	0"
Left Side	1"	0"
5. This appliance is manufactured for commercial installation only and is not intended for home use.

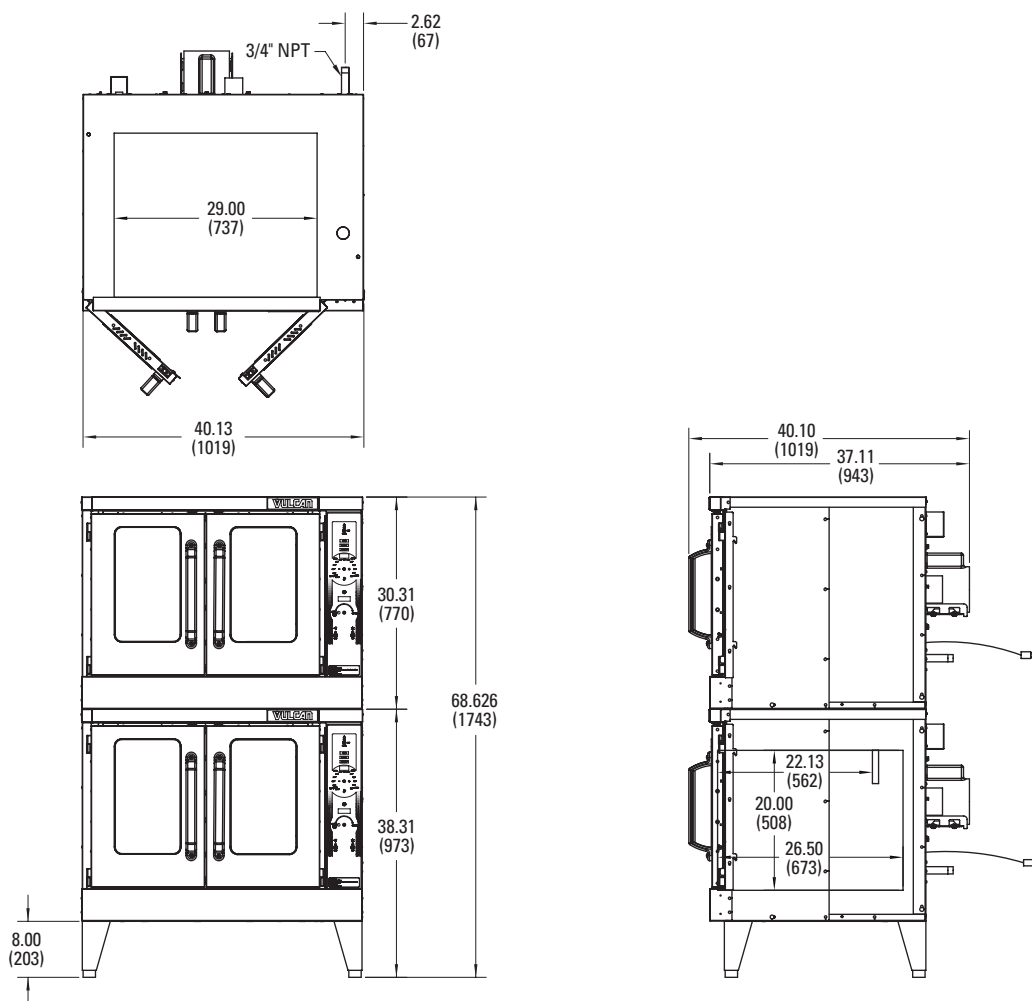

MODEL NO.	WIDTH	DEPTH (INCLUDES HANDLES)	HEIGHT	BTU/HR. PER OVEN	TOTAL BTU/HR.	ELECTRICAL	WEIGHT			
							WITH SKID & PACKAGING		WITHOUT SKID & PACKAGING	
							LBS.	KG	LBS.	KG
VC55G	40"	40"	68¾"	50,000	100,000	120/60/1	778	352	666	302



a division of ITW Food Equipment Group LLC

P.O. Box 696 ■ Louisville, KY 40201 ■ Toll-free: 1-800-814-2028 ■ Local: 502-778-2791 ■ Quote & Order Fax: 1-800-444-0602

NOTE: In line with its policy to continually improve its products, Vulcan reserves the right to change materials and specifications without notice.

## Engineering Specification

Job Name \_\_\_\_\_ Contractor \_\_\_\_\_  
 Job Location \_\_\_\_\_ Approval \_\_\_\_\_  
 Engineer \_\_\_\_\_ Contractor's P.O. No. \_\_\_\_\_  
 Approval \_\_\_\_\_ Representative \_\_\_\_\_  
 SKU \_\_\_\_\_

# SnapFast® Quick-Disconnect Assemblies

Sizes: ½" to 1¼"

SnapFast Quick-Disconnect Assemblies feature flexible movement and the one-handed quick-disconnect fitting with a unique thermal shut-off design that automatically shuts off the gas when the internal temperature exceeds 350°F (177°C).

## Features

### SnapFast® One-Handed Quick-Disconnect

Quick-Disconnect .....	Brass body, aluminum collar
Thermal Shut-off .....	Shuts off gas when internal temperatures exceed 350°F (177°C)

### Additional Components

Restraining Device .....	PVC coated, steel multi-strand cable and mounting hardware
Valve .....	Full port, brass body
Elbow .....	Malleable iron
*Deluxe Kits Include .....	The Dormont Blue Hose, valve, restraining device, elbows, SnapFast, display box

## Specifications

### The Dormont Blue Hose®

Tubing .....	Annealed, 304 stainless steel
Braiding .....	Multi-strand, stainless steel wire
Coating .....	Blue antimicrobial PVC, melts at 350°F (177°C); coating will not hold a flame
End Fittings.....	Carbon steel; zinc trivalent chromate
Stress Guard®.....	360° rotational end fitting at both ends

**Safety System™** The Dormont Safety System™ is the first and only complete gas equipment connection system specifically engineered for the commercial kitchen. The Safety System consists of the famous Dormont Blue Hose and a variety of accessories designed for improved safety and performance in commercial kitchens. Because they are manufactured in the USA under an ISO qualified production process and to multiple design certifications, you can Connect with Confidence with the Dormont Safety System.

### NOTICE

The information contained herein is not intended to replace the full product installation and safety information available or the experience of a trained product installer. You are required to thoroughly read all installation instructions and product safety information before beginning the installation of this product.

Dormont product specifications in U.S. customary units and metric are approximate and are provided for reference only. For precise measurements, please contact Dormont Technical Service. Dormont reserves the right to change or modify product design, construction, specifications, or materials without prior notice and without incurring any obligation to make such changes and modifications on Dormont products previously or subsequently sold. Refer to the owner's manual for warranty information.

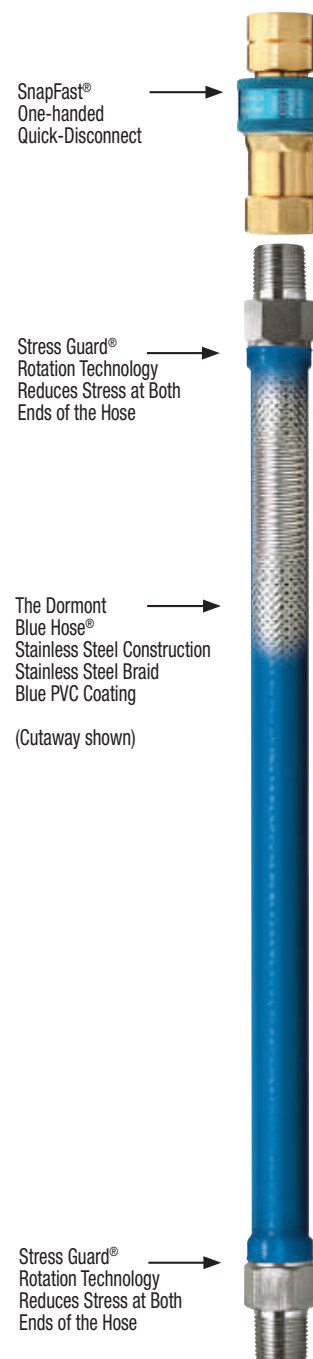

**Dormont®**  
 A WATTS Brand



## Approvals & Certifications



NSF/ANSI 169 – Special-purpose food equipment and devices

ANSI Z21.69 / CSA 6.16 – Connectors for moveable gas appliances

ANSI Z21.41 / CSA 6.9 – Quick-disconnect devices for use with gas fuel appliances

ANSI Z21.15 / CSA 9.1 – Manually operated gas valves for appliances, appliance connectors

Meets requirements of ANSI Z223.1 / NFPA 54 National Fuel Gas Code

Not for use in temperatures less than 32°F (0°C). For indoor use only.

Max operating pressure 1/2 psi.

Refer to the catalog for additional approvals and certifications or go to [www.dormont.com](http://www.dormont.com).

**A restraining device is required for all moveable gas equipment.**

## SnapFast® Quick-Disconnect Deluxe Kit Assembly

### Ordering Information

CONFIGURATION	SIZE I.D.	24" (607MM)	36" (914MM)	48" (1,219MM)	60" (1,524MM)	72" (1,829MM)
Deluxe Kit*	½"	1650KIT24	1650KIT36	1650KIT48	1650KIT60	1650KIT72
Basic Kit**		1650BPQR24	1650BPQR36	1650BPQR48	1650BPQR60	1650BPQR72
Hose Assembly***		1650BPQ24	1650BPQ36	1650BPQ48	1650BPQ60	1650BPQ72
Deluxe Kit*	¾"	1675KIT24	1675KIT36	1675KIT48	1675KIT60	1675KIT72
Basic Kit**		1675BPQR24	1675BPQR36	1675BPQR48	1675BPQR60	1675BPQR72
Hose Assembly***		1675BPQ24	1675BPQ36	1675BPQ48	1675BPQ60	1675BPQ72
Deluxe Kit*	1"	16100KIT24	16100KIT36	16100KIT48	16100KIT60	16100KIT72
Basic Kit**		16100BPQR24	16100BPQR36	16100BPQR48	16100BPQR60	16100BPQR72
Hose Assembly***		16100BPQ24	16100BPQ36	16100BPQ48	16100BPQ60	16100BPQ72
Deluxe Kit*	1¼"	16125KIT24	16125KIT36	16125KIT48	16125KIT60	16125KIT72
Basic Kit**		16125BPQR24	16125BPQR36	16125BPQR48	16125BPQR60	16125BPQR72
Hose Assembly***		16125BPQ24	16125BPQ36	16125BPQ48	16125BPQ60	16125BPQ72

### BTU/hr Flow Capacity Natural Gas

(Flow rating BTU/hr 0.64 SP. GR. @ 0.5 inch WC pressure drop)

MODEL	SIZE I.D.	LENGTH				
		24" (607MM)	36" (914MM)	48" (1,219MM)	60" (1,524MM)	72" (1,829MM)
1650BPQ	½"	87,000	77,000	68,000	60,000	55,000
1675BPQ	¾"	232,000	218,000	180,000	158,000	139,000
16100BPQ	1"	414,000	379,000	334,000	294,000	279,000
16125BPQ	1¼"	699,000	615,000	541,000	476,000	419,000

\* **Deluxe Kits include:** The Dormont Blue Hose and restraining device, full port valve and (2) street elbows

\*\***Basic Kits include:** The Dormont Blue Hose and restraining device, street elbow and SnapFast

\*\*\***Hose Assemblies include:** The Dormont Blue Hose, SnapFast and street elbow

## Typical Installation



## Options

### The Dormont Blue Hose®

The Dormont Blue Hose is a commercial, moveable-grade gas connector designed for use with moveable equipment.

Moveable equipment is defined in ANSI Standard Z21.69/CSA 6.16 as gas utilization equipment that may be mounted on casters or otherwise be subject to movement.



- One-handed quick-disconnect fitting
- Thermal shut-off when internal temperature exceeds 350°F (177°C)



### Restraining Device

- ANSI Z21.69 Standard section 1.7.4 states: Connectors when used on caster-mounted equipment shall be installed with a restraining device, which prevents transmission of the strain to the connector



**We guarantee our commercial gas connectors for the life of the original appliance to which it is connected.**

### Safety-Set®

#### Benefits

- Can be used with all caster-mounted equipment including cooking appliances, warming carts, salad bars, and refrigerators
- Crush Resistant
- Resistant to oils and greases
- Open-floor design allows appliance to rest level on the floor to ensure even cooking



#### Features

- Compatible with 4", 5", and 6" casters
- Certified to NSF/ANSI Standard 169 – Special Purpose Food Equipment & Devices
- Flexible, tough injection molded Thermoplastic Polyurethane (TPU)
- Able to withstand 1,000 PSI of crush pressure

#### Ordering Instructions:

The Safety-Set wheel positioning product can be ordered individually or with the Blue Hose Kit.

The Safety-Set model name is "PS" and the ordering number is 0241002.

When ordering the Safety-Set with the Blue Hose kit, simply add the letters "PS" to the end of the model number.

# Dormont®

A WATTS Brand

USA: T: (800) 367-6668 • F: (724) 733-4808 • Dormont.com



## C24DA SERIES

Direct Steam Convection Steamer  
on Cabinet Base



Model C24DA10



ANSI/NSF Standard #4



### SPECIFIER STATEMENT

Two compartment direct potable steam convection steamer on cabinet base. Stainless steel exterior. Two stainless steel cooking compartments with covered interior corners. Separate 60 minute timer with constant steam feature for each compartment. Heavy duty doors and door latch mechanisms. Stainless steel water resistant cabinet base. 6" adjustable stainless steel legs with flanged feet. 3/4" NPT direct potable steam connection and pressure regulator. Requires 120/60/1 power supply, 2.0 amps maximum draw, with 6 foot power cord and 3 prong plug. Single 3/4" hose bib water line connection for untreated water. 1 1/2" NPT drain connection.

#### Exterior Dimensions:

6 pan: 24"w x 35.4"d x 59"h on 6" legs

10 pan: 24"w x 35.4"d x 72"h on 6" legs

UL Listed. Classified by UL to NSF Standard #4.

Project \_\_\_\_\_

AIA # \_\_\_\_\_ SIS # \_\_\_\_\_

Item # \_\_\_\_\_ Quantity \_\_\_\_\_ C.S.I. Section 114000

### MODELS

- C24DA6** 6 pan capacity, basic controls
- C24DA10** 10 pan capacity, basic controls

### STANDARD FEATURES

- Stainless steel exterior
- Two stainless steel cooking compartments with coved interior corners
- Separate 60 minute timer with constant steam feature for each compartment
- Heavy duty doors and door latch mechanisms
- Stainless steel water resistant cabinet base
- 6" adjustable stainless steel legs with flanged feet
- 3/4" NPT direct potable steam connection and pressure regulator
- Requires 120/60/1 power supply, 2.0 amps maximum draw.
- Single 3/4" hose bib water line connection for untreated water
- 1 1/2" NPT drain connection
- One year limited parts and labor warranty

### OPTIONS

- Second year extended limited parts and labor warranty contract
- Steamer Security Package, includes controls protected by lockable cover, perforated flue cover, security fasteners & tack-welds

### ACCESSORIES (PACKAGED AND SOLD SEPARATELY)

- Stainless steel pan cover, Qty. \_\_\_\_\_
- Removable sliding shelf, Qty. \_\_\_\_\_

C24DA SERIES – Direct Steam Convection Steamer on Cabinet Base

Approved by \_\_\_\_\_ Date \_\_\_\_\_ Approved by \_\_\_\_\_ Date \_\_\_\_\_



# C24DA SERIES

## Direct Steam Convection Steamer on Cabinet Base

### SERVICE CONNECTIONS

- ELECTRICAL CONNECTIONS:** Unless otherwise specified, Field Wire Electrical Connection to be 120/60/1 with grounding wire. Maximum amps 2.0.
- DRAIN:** Condenser box and compartment, 1½" NPT. (Provide an open air gap type drain within 72" of condenser box and for best results at a distance so steam vapors will not enter the steamer from underneath the control area. Do not connect solidly to any drain connection.)
- POTABLE STEAM CONNECTION:** ¾" NPT. Supply line 80 lbs./hr. required at 10-50 PSI (69-345 kPa).
- CONDENSING WATER SUPPLY:** ¾" hose bib fitting at 20-60 psi. (138-414 kPa).

### WATER QUALITY STATEMENT

The fact that a water supply is potable is no guarantee that it is suitable for steam generation. Your water supply must be within these general guidelines:

<b>SUPPLY PRESSURE</b>	20 - 60 psig
<b>HARDNESS*</b>	less than 3 grains
<b>SILICA</b>	less than 13 ppm
<b>TOTAL CHLORIDE</b>	less than 4.0 ppm
<b>pH RANGE</b>	7-8
<b>UN-DISSOLVED SOLIDS</b>	less than 5 microns

\* 17.1 ppm = 1 grain of hardness

Other factors affecting steam generation are iron content, amount of chloridation and dissolved gases. Water supplies vary from state to state and from locations within a state. Therefore it is necessary that the local water treatment specialist be consulted before the installation of any steam generating equipment.

### NOTES

- Dimensions which locate the above connections have a tolerance of + or - 3" (+ or - 75mm). Normal dimensions are in inches. Dimensions in [ ] are in millimeters.
- Installation of backflow preventer's, vacuum breakers and other specific code requirements is the responsibility of the owner and installer. It is the responsibility of the owner and installer to comply with local codes.
- Do not use plastic or PVC drains.
- This appliance is manufactured for commercial installation only and is not intended for home use.

Compartment Pan Capacity				
Model	1"	2½"	4"	6"
C24DA6	6	3	2	1
C24DA10	10	5	3	2

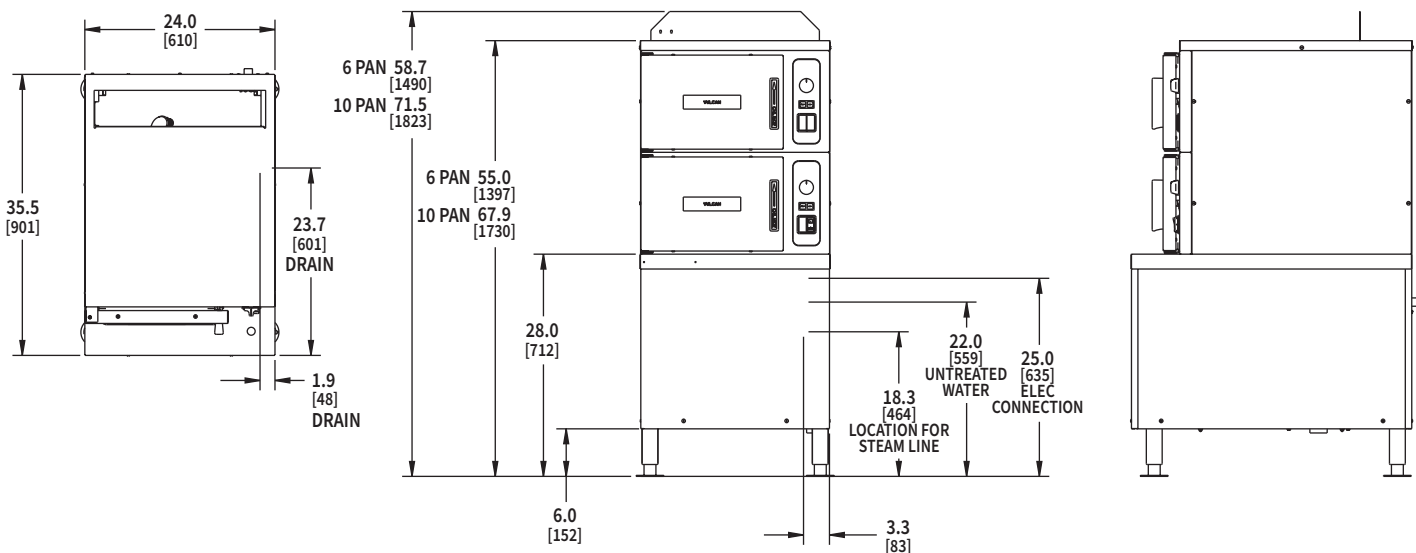

[CAD and/or Revit Files Available](#)

As continued product improvement is a policy of Vulcan, specifications are subject to change without notice.



## KELT SERIES

Electric Floor Mounted Tilting  
 $\frac{2}{3}$  Jacketed Kettles



Model K40ELT



### SPECIFIER STATEMENT

Electric self-contained, stainless steel,  $\frac{2}{3}$  jacketed floor mounted tilting steam kettle. Ellipsoidal bottom kettle liner formed and fully welded type 316 and type 304 stainless steel exterior with ( $\frac{1}{4}$  x  $\frac{5}{8}$  inch 20 gallons) ( $\frac{3}{8}$  x 1 inch 40 gallons and greater) bar rim, embossed gallon/liter markings. 50 psi (3.4 kg/cm<sup>2</sup>) steam jacket rating. Stainless steel enclosure for controls, self-locking tilt mechanism and faucet bracket. Controls include a power switch, power "on" light, solid state temperature control, vacuum/pressure gauge, pressure relief valve, low water light and low water shut-off. Kettle tilts forward 90° to completely empty. Tubular stainless steel legs with flanged feet.

UL listed. UL Classified for sanitation in accordance with ANSI/NSF Standard #4. Meets ASME code.

Project \_\_\_\_\_

AIA # \_\_\_\_\_ SIS # \_\_\_\_\_

Item # \_\_\_\_\_ Quantity \_\_\_\_\_ C.S.I. Section 114000

### MODELS

- K20ELT** 12 KW, 20 gallon true working capacity
- K40ELT** 18 KW, 40 gallon true working capacity
- K60ELT** 18 KW, 60 gallon true working capacity

### STANDARD FEATURES

- Electric self-contained, stainless steel,  $\frac{2}{3}$  jacketed floor mounted tilting steam kettle
- Ellipsoidal bottom kettle liner formed and fully welded standard type 316 and type 304 stainless steel exterior
- Heavy bar rim ( $\frac{1}{4}$  x  $\frac{5}{8}$  inch 20 gallons) ( $\frac{3}{8}$  x 1 inch 40 gallons and greater)
- Embossed gallon/liter markings
- 50 psi (3.4 kg/cm<sup>2</sup>) steam jacket rating
- Stainless steel enclosure for "water resistant" controls, self-locking tilt mechanism and faucet bracket
- Controls include a power switch, power "on" light, solid state temperature control, vacuum/pressure gauge, pressure relief valve, low water light and low water shut-off
- Kettle tilts forward 95° to completely empty
- Tubular stainless steel legs with flanged feet
- One year limited parts and labor warranty

### OPTIONS

- Two inch compression tangent draw-off valve with perforated strainer
- Two inch plug tangent draw-off valve with perforated strainer
- Three inch compression tangent draw-off valve with perforated strainer
- Security facility package:
  - a. Security type fasteners with tack welds
  - b. Stainless steel step over draw-off valve with chain
  - c. Controls cover
  - d. Chained crank handle
- 480 volt, 60 Hz, 3 phase power supply
- Second year extended limited parts and labor warranty

### ACCESSORIES (PACKAGED AND SOLD SEPARATELY)

- Spring assist hinged stainless steel cover with condensate ring and drop down lift handle
- Pouring lip strainer
- Clean-up kit, includes draw-off brush, clean-up brush and paddle scraper with 40" handle
- Stainless steel 48" whip
- Non-perforated strainer
- (12") (18" double jointed) single pantry lead-free faucet
- (12") (18" double jointed) double pantry lead-free faucet
- Double pantry washdown hose with 16" add-on lead-free faucet with vacuum breaker
- Double pantry washdown hose with lead-free vacuum breaker
- Double pantry pot filler with lead-free vacuum breaker

**KELT SERIES – Electric Floor Mounted Tilting  $\frac{2}{3}$  Jacketed Kettles**

Approved by \_\_\_\_\_ Date \_\_\_\_\_ Approved by \_\_\_\_\_ Date \_\_\_\_\_



# KELT SERIES

## Electric Floor Mounted Tilting 2/3 Jacketed Kettles

### SERVICE CONNECTIONS

**Electrical Connection:** Single point supply 1½" (29 mm) dia. (¾" conduit).

### TRUE WORKING CAPACITIES (IN 4 OZ. SERVINGS)

80 quarts/20 gallons/76 liters/640 servings  
 120 quarts/40 gallons/152 liters/1,280 servings  
 160 quarts/60 gallons/228 liters/1,920 servings

**INSTALLATION MANUAL**

### NOTES

- Dimensions which locate the above connections have a tolerance of + or -3" (+ or -75 mm).
- Installation of backflow preventers, vacuum breakers and other specific code requirements is the responsibility of the owner and installer. It is the responsibility of the owner and installer to comply with local codes.
- This appliance is manufactured for commercial installation only and is not intended for home use.

Model	kW	Phase	Amperage per Line			Minimum Circuit Ampacity			Field Note
			208V	240V	480V	208V	240V	480V	
K20ELT	12	1	57.7	—	—	75	—	—	Electrical requirements must be specified upon order.  This is not field convertible.
		3	33.3	—	14.4	45	—	20	
	16	1	—	66.7	—	—	85	—	
		3	—	38.5	—	—	50	—	
Standard K40ELT, K60ELT	18	3	50.0	43.3	21.7	65	55	30	

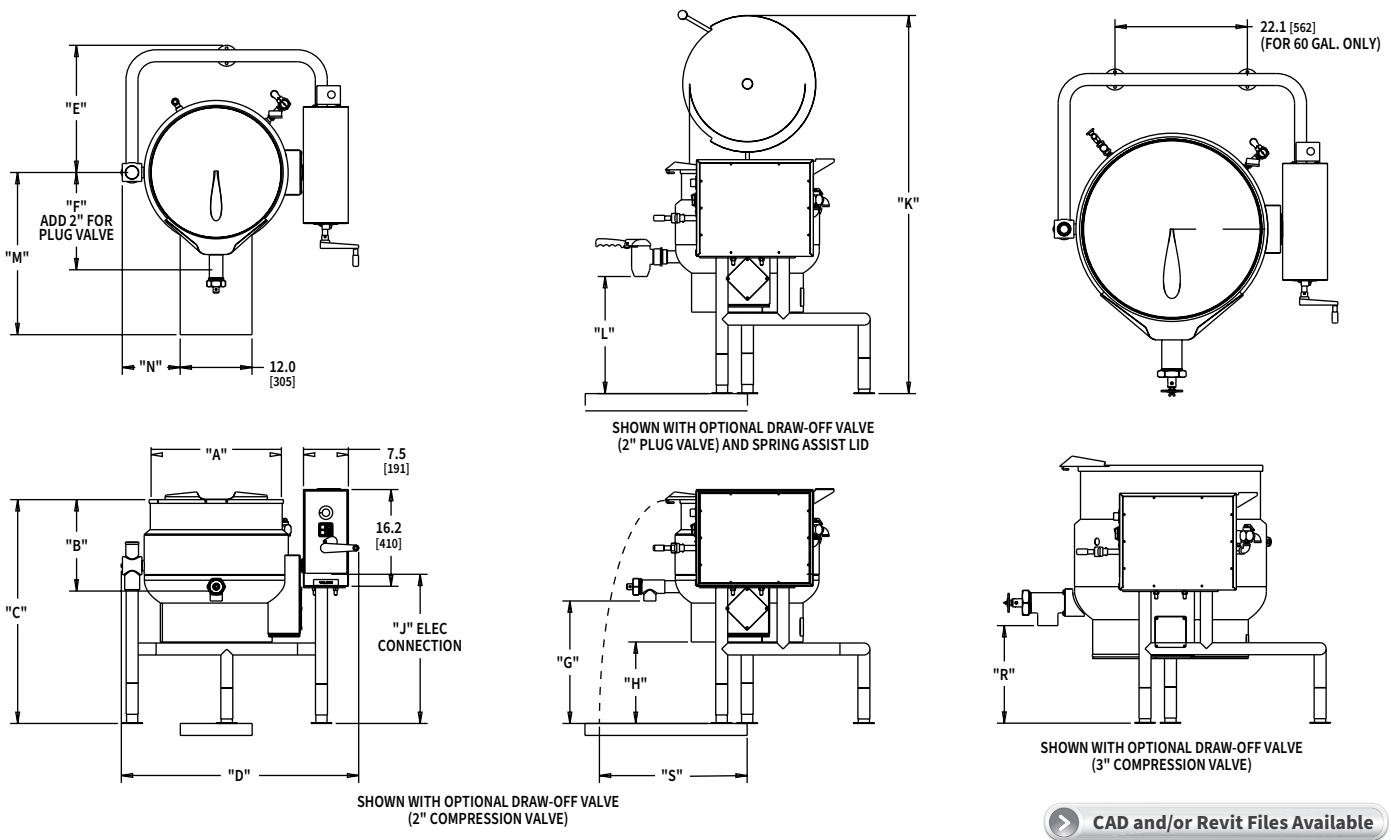

Model	True Working Capacity	A	B	C	D	E	F	G	H	J	K	L	M	N	R	S
K20ELT	20 gallons	21.8	15.4	37.4	39.7	21.3	16.3	20.5	13.6	24.9	63.2	19.6	27.1	9.7		25.1
	76 liters	554	391	950	1008	541	414	521	345	632	1605	498	688	246		638
K40ELT	40 gallons	25.8	21.2	39.7	43.5	24.0	18.1	16.9	12.0	22.9	69.4	16.0	32.1	11.7	15.9	30.1
	152 liters	655	538	1008	1105	610	460	429	305	582	1763	406	815	297	404	765
K60ELT	60 gallons	29.7	24.1	43.1	47.5	26.8	20.3	17.3	10.8	24.3	76.6	16.6	34.8	13.8	16.3	32.8
	227 liters	754	612	1095	1207	681	516	439	274	617	1946	422	884	351	414	833

As continued product improvement is a policy of Vulcan, specifications are subject to change without notice.



## RESTAURANT RANGES

**VULCAN****ENDURANCE GAS RESTAURANT RANGE**  
**2 OPEN BURNERS / 36" GRIDDLE**  
**48" WIDE GAS RANGE**

**Model 48S-2B36GN**  
(shown with optional casters)

**SPECIFICATIONS**

48" wide gas restaurant range, Vulcan Model No. 48S-2B36GN. Fully MIG welded aluminized steel frame for added durability. Stainless steel front, sides, backriser, highshelf and 6" adjustable legs. Extra deep crumb tray with welded corners. Two 30,000 BTU/hr. open top burners with lift-off burner heads. Energy saving flashtube open burner ignition system (one pilot for every two burners) shrouded for reliability. Heavy duty cast grates, easy lift-off 12" x 12½" in the front and 12" x 14½" in the back to better accommodate stock pots or large pans. Grates have a built in aeration bowl for greater efficiency. Burner knobs are cool to the touch, high temperature material. One oven: 35,000 BTU/hr. standard bakers depth ovens with porcelain oven bottom and door panel, measures 27"d x 26⅜"w x 14"h. Oven thermostat adjusts from 250°F to 500°F with a low setting. Oven is supplied with two racks, two rack guide sets, and four rack positions. Oven door is heavy duty with an integrated door hinge/spring mechanism requiring no adjustment. 1" rear gas connections with rear manifold and pressure regulator. Total input 155,000 BTU/hr.

**Exterior Dimensions:**

34"d x 48"w x 58"h on 6" adjustable legs

- 48S-2B36GN** 1 Standard Oven / Natural Gas
- 48S-2B36GP** 1 Standard Oven / Propane
- 48C-2B36GN** 1 Convection Oven / Natural Gas
- 48C-2B36GP** 1 Convection Oven / Propane

**STANDARD FEATURES**

- Fully MIG welded frame
- Stainless steel front, sides, backriser, lift-off high shelf
- 6" stainless steel adjustable legs
- Two open top burners, each burner is 30,000 BTU/hr. with lift-off burner heads
- Shrouded flash tube pilot system (one pilot per two burners)
- Heavy duty cast grates, easy lift-off 12" x 12½" in front and 12" x 14½" in the rear
- 36" manual griddle, ¾" thick, 4" wide front grease trough
- Extra deep pull out crumb tray with welded corners
- 35,000 BTU/hr. baker's depth standard oven cavity. Full size sheet pans fit side-to-side or front-to-back.
- Oven thermostat adjusts from 250°F to 500°F
- Heavy duty cool touch oven door handle
- Two oven racks and four rack positions
- 35,000 BTU/hr. convection oven in place of standard oven 24"d x 26⅜"w x 13⅞"h (115v - 1 phase blower motor 4 amp, 6' cord and plug). Full size sheet pans only fit side-to-side in convection oven. Convection oven motor requires field attachment.
- 1" rear gas connection and pressure regulator
- One year limited parts and labor warranty

**ACCESSORIES** (Packaged & Sold Separately)

- Extra oven rack with rack guides
- Casters (set of eight)
- Flanged feet (set of four)
- 10" stainless steel stub back
- Reinforced high shelf for mounting salamander broiler

**OPTIONS** (Factory Installed)

- Thermostatically controlled griddle (snap action)
- Flame Safety device with manual spark ignition for all open top burners, thermostatic griddles and oven pilots
- Hot tops

**VULCAN**

a division of ITW Food Equipment Group LLC

P.O. Box 696 ■ Louisville, KY 40201 ■ Toll-free: 1-800-814-2028 ■ Local: 502-778-2791 ■ Quote &amp; Order Fax: 1-800-444-0602

RESTAURANT RANGES



**ENDURANCE GAS RESTAURANT RANGE**  
**2 OPEN BURNERS / 36" GRIDDLE**  
**48" WIDE GAS RANGE**

**INSTALLATION INSTRUCTIONS**

1. A pressure regulator sized for this unit is included. Natural gas 5.0" W.C., propane gas 10.0" W.C.
2. Gas line connecting to range must be 1" or larger. If flexible connectors are used, the inside diameter must be 1" or larger.
3. An adequate ventilation system is required for commercial cooking equipment. Information may be obtained by writing to the National Fire Protection Association, 1 Batterymarch Park, Quincy, MA 02269, www.NFPA.org. When writing, refer to NFPA No. 96.
4. These units are manufactured for installation in accordance with ANSZ223.1A (latest edition), National Fuel Gas Code. Copies may be obtained from The American Gas Association, 400 N Capitol St. NW, Washington, DC 20001, www.AGA.org.

5. Clearances	Rear	Sides
Combustible	6"	10"
Standard Oven Non-combustible	0"	0"
Convection Oven Non-combustible	Min. 4"	0"

6. For proper combustion, install equipment on adjustable legs or casters provided with unit.

**NOTE:** In line with its policy to continually improve its product, Vulcan reserves the right to change materials and specifications without notice.

**Specify type of gas when ordering.**  
**Specify altitude when above 2,000 feet.**

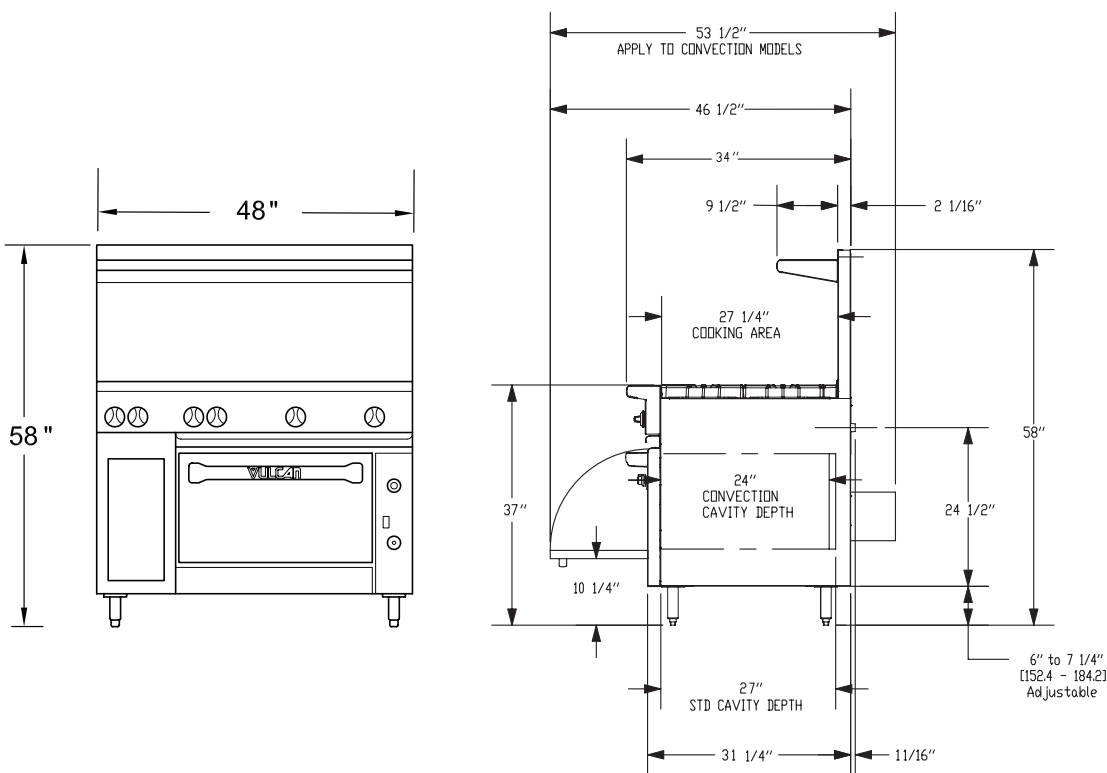

TOP CONFIGURATION	MODEL NUMBER	DESCRIPTION	TOTAL INPUT BTU / HR	SHIPPING WEIGHT LBS / KG
	<b>48S-2B36GN</b>	1 Standard Oven / 2 Burners / 36" Griddle / Natural Gas	155,000	750 / 341
	<b>48S-2B36GP</b>	1 Standard Oven / 2 Burners / 36" Griddle / Propane	155,000	750 / 341
	<b>48C-2B36GN</b>	1 Convection Oven / 2 Burners / 36" Griddle / Natural Gas	155,000	810 / 368
	<b>48C-2B36GP</b>	1 Convection Oven / 2 Burners / 36" Griddle / Propane	155,000	810 / 368

This appliance is manufactured for commercial use only and is not intended for home use.



a division of ITW Food Equipment Group LLC

P.O. Box 696 ■ Louisville, KY 40201 ■ Toll-free: 1-800-814-2028 ■ Local: 502-778-2791 ■ Quote & Order Fax: 1-800-444-0602

**NOTE:** In line with its policy to continually improve its products, Vulcan reserves the right to change materials and specifications without notice.



## Engineering Specification

Job Name \_\_\_\_\_ Contractor \_\_\_\_\_  
 Job Location \_\_\_\_\_ Approval \_\_\_\_\_  
 Engineer \_\_\_\_\_ Contractor's P.O. No. \_\_\_\_\_  
 Approval \_\_\_\_\_ Representative \_\_\_\_\_  
 SKU \_\_\_\_\_

# SnapFast® Quick-Disconnect Assemblies

Sizes: ½" to 1¼"

SnapFast Quick-Disconnect Assemblies feature flexible movement and the one-handed quick-disconnect fitting with a unique thermal shut-off design that automatically shuts off the gas when the internal temperature exceeds 350°F (177°C).

## Features

### SnapFast® One-Handed Quick-Disconnect

Quick-Disconnect ..... Brass body, aluminum collar  
 Thermal Shut-off ..... Shuts off gas when internal temperatures exceed 350°F (177°C)

### Additional Components

Restraining Device ..... PVC coated, steel multi-strand cable and mounting hardware  
 Valve ..... Full port, brass body  
 Elbow ..... Malleable iron  
 \*Deluxe Kits Include ..... The Dormont Blue Hose, valve, restraining device, elbows, SnapFast, display box

## Specifications

### The Dormont Blue Hose®

Tubing ..... Annealed, 304 stainless steel  
 Braiding ..... Multi-strand, stainless steel wire  
 Coating ..... Blue antimicrobial PVC, melts at 350°F (177°C); coating will not hold a flame  
 End Fittings ..... Carbon steel; zinc trivalent chromate  
 Stress Guard® ..... 360° rotational end fitting at both ends

**Safety System™** The Dormont Safety System™ is the first and only complete gas equipment connection system specifically engineered for the commercial kitchen. The Safety System consists of the famous Dormont Blue Hose and a variety of accessories designed for improved safety and performance in commercial kitchens. Because they are manufactured in the USA under an ISO qualified production process and to multiple design certifications, you can Connect with Confidence with the Dormont Safety System.

### NOTICE

The information contained herein is not intended to replace the full product installation and safety information available or the experience of a trained product installer. You are required to thoroughly read all installation instructions and product safety information before beginning the installation of this product.

Dormont product specifications in U.S. customary units and metric are approximate and are provided for reference only. For precise measurements, please contact Dormont Technical Service. Dormont reserves the right to change or modify product design, construction, specifications, or materials without prior notice and without incurring any obligation to make such changes and modifications on Dormont products previously or subsequently sold. Refer to the owner's manual for warranty information.



**Dormont®**  
 A WATTS Brand

## Approvals & Certifications



NSF/ANSI 169 – Special-purpose food equipment and devices

ANSI Z21.69 / CSA 6.16 – Connectors for moveable gas appliances

ANSI Z21.41 / CSA 6.9 – Quick-disconnect devices for use with gas fuel appliances

ANSI Z21.15 / CSA 9.1 – Manually operated gas valves for appliances, appliance connectors

Meets requirements of ANSI Z223.1 / NFPA 54 National Fuel Gas Code

Not for use in temperatures less than 32°F (0°C). For indoor use only.

Max operating pressure 1/2 psi.

Refer to the catalog for additional approvals and certifications or go to [www.dormont.com](http://www.dormont.com).

**A restraining device is required for all moveable gas equipment.**

## SnapFast® Quick-Disconnect Deluxe Kit Assembly

### Ordering Information

CONFIGURATION	SIZE I.D.	24" (607MM)	36" (914MM)	48" (1,219MM)	60" (1,524MM)	72" (1,829MM)
Deluxe Kit*	½"	1650KIT24	1650KIT36	1650KIT48	1650KIT60	1650KIT72
Basic Kit**		1650BPQR24	1650BPQR36	1650BPQR48	1650BPQR60	1650BPQR72
Hose Assembly***		1650BPQ24	1650BPQ36	1650BPQ48	1650BPQ60	1650BPQ72
Deluxe Kit*	¾"	1675KIT24	1675KIT36	1675KIT48	1675KIT60	1675KIT72
Basic Kit**		1675BPQR24	1675BPQR36	1675BPQR48	1675BPQR60	1675BPQR72
Hose Assembly***		1675BPQ24	1675BPQ36	1675BPQ48	1675BPQ60	1675BPQ72
Deluxe Kit*	1"	16100KIT24	16100KIT36	16100KIT48	16100KIT60	16100KIT72
Basic Kit**		16100BPQR24	16100BPQR36	16100BPQR48	16100BPQR60	16100BPQR72
Hose Assembly***		16100BPQ24	16100BPQ36	16100BPQ48	16100BPQ60	16100BPQ72
Deluxe Kit*	1¼"	16125KIT24	16125KIT36	16125KIT48	16125KIT60	16125KIT72
Basic Kit**		16125BPQR24	16125BPQR36	16125BPQR48	16125BPQR60	16125BPQR72
Hose Assembly***		16125BPQ24	16125BPQ36	16125BPQ48	16125BPQ60	16125BPQ72

### BTU/hr Flow Capacity Natural Gas

(Flow rating BTU/hr 0.64 SP. GR. @ 0.5 inch WC pressure drop)

MODEL	SIZE I.D.	LENGTH				
		24" (607MM)	36" (914MM)	48" (1,219MM)	60" (1,524MM)	72" (1,829MM)
1650BPQ	½"	87,000	77,000	68,000	60,000	55,000
1675BPQ	¾"	232,000	218,000	180,000	158,000	139,000
16100BPQ	1"	414,000	379,000	334,000	294,000	279,000
16125BPQ	1¼"	699,000	615,000	541,000	476,000	419,000

\* **Deluxe Kits include:** The Dormont Blue Hose and restraining device, full port valve and (2) street elbows

\*\***Basic Kits include:** The Dormont Blue Hose and restraining device, street elbow and SnapFast

\*\*\***Hose Assemblies include:** The Dormont Blue Hose, SnapFast and street elbow

## Typical Installation



## Options

### The Dormont Blue Hose®

The Dormont Blue Hose is a commercial, moveable-grade gas connector designed for use with moveable equipment.

Moveable equipment is defined in ANSI Standard Z21.69/CSA 6.16 as gas utilization equipment that may be mounted on casters or otherwise be subject to movement.



- One-handed quick-disconnect fitting
- Thermal shut-off when internal temperature exceeds 350°F (177°C)



### Restraining Device

- ANSI Z21.69 Standard section 1.7.4 states: Connectors when used on caster-mounted equipment shall be installed with a restraining device, which prevents transmission of the strain to the connector



**We guarantee our commercial gas connectors for the life of the original appliance to which it is connected.**

### Safety-Set®

#### Benefits

- Can be used with all caster-mounted equipment including cooking appliances, warming carts, salad bars, and refrigerators
- Crush Resistant
- Resistant to oils and greases
- Open-floor design allows appliance to rest level on the floor to ensure even cooking



#### Features

- Compatible with 4", 5", and 6" casters
- Certified to NSF/ANSI Standard 169 – Special Purpose Food Equipment & Devices
- Flexible, tough injection molded Thermoplastic Polyurethane (TPU)
- Able to withstand 1,000 PSI of crush pressure

#### Ordering Instructions:

The Safety-Set wheel positioning product can be ordered individually or with the Blue Hose Kit.

The Safety-Set model name is "PS" and the ordering number is 0241002.

When ordering the Safety-Set with the Blue Hose kit, simply add the letters "PS" to the end of the model number.

**Dormont**  
A WATTS Brand

USA: T: (800) 367-6668 • F: (724) 733-4808 • Dormont.com

## RESTAURANT RANGES

**VULCAN****ENDURANCE GAS RESTAURANT RANGE  
6 OPEN BURNERS  
36" WIDE GAS RANGE**

**Model 36S-6BN**  
(shown with optional casters)

**SPECIFICATIONS**

36" wide gas restaurant range, Vulcan Model No. 36S-6BN. Fully MIG welded aluminized steel frame for added durability. Stainless steel front, sides, backriser, highshelf and 6" adjustable legs. Extra deep crumb tray with welded corners. Six 30,000 BTU/hr. open top burners with lift-off burner heads. Energy saving flashtube open burner ignition system (one pilot for every two burners) shrouded for reliability. Heavy duty cast grates, easy lift-off 12" x 12½" in the front and 12" x 14½" in the back to better accommodate stock pots or large pans. Grates have a built in aeration bowl for greater efficiency. Burner knobs are cool to the touch, high temperature material. One oven: 35,000 BTU/hr. standard bakers depth ovens with porcelain oven bottom and door panel, measures 27"d x 26¾"w x 14"h. Oven thermostat adjusts from 250°F to 500°F with a low setting. Oven is supplied with two racks, two rack guide sets, and four rack positions. Oven door is heavy duty with an integrated door hinge/spring mechanism requiring no adjustment. ¾" rear gas connection and pressure regulator. Total input 215,000 BTU/hr.

**Exterior Dimensions:**

34"d x 36"w x 58"h on 6" adjustable legs

- 36S-6BN** 1 Standard Oven / Natural Gas
- 36S-6BP** 1 Standard Oven / Propane
- 36C-6BN** 1 Convection Oven / Natural Gas
- 36C-6BP** 1 Convection Oven / Propane

**STANDARD FEATURES**

- Fully MIG welded frame
- Stainless steel front, sides, backriser, lift-off high shelf
- 6" stainless steel adjustable legs
- Six open top burners, each burner is 30,000 BTU/hr. with lift-off burner heads
- Shrouded flash tube pilot system (one pilot per two burners)
- Heavy duty cast grates, easy lift-off 12" x 12½" in front and 12" x 14½" in the rear
- Extra deep pull out crumb tray with welded corners
- 35,000 BTU/hr. baker's depth standard oven cavity. Full size sheet pans fit side-to-side or front-to-back.
- Oven thermostat adjusts from 250°F to 500°F
- Two oven racks and four rack positions
- 35,000 BTU/hr. convection oven in place of standard oven, 24"d x 26¾"w x 13⅞"h (115v - 1 phase blower motor 4 amp, 6' cord and plug), includes three oven racks. Full size sheet pans only fit side-to-side in convection oven. Convection oven motor requires field attachment.
- One year limited parts and labor warranty

**ACCESSORIES** (Packaged & Sold Separately)

- Extra oven rack with rack guides
- Casters (set of four)
- Leveling casters (set of four)
- Flanged feet (set of four)
- 10" stainless steel stub back
- Reinforced high shelf for mounting salamander broiler

**OPTIONS** (Factory Installed)

- Flame Safety device with manual spark ignition for all open top burners, thermostatic griddles and oven pilots
- Hot tops

**VULCAN**

a division of ITW Food Equipment Group LLC

P.O. Box 696 ■ Louisville, KY 40201 ■ Toll-free: 1-800-814-2028 ■ Local: 502-778-2791 ■ Quote &amp; Order Fax: 1-800-444-0602

RESTAURANT RANGES



**ENDURANCE GAS RESTAURANT RANGE**  
**6 OPEN BURNERS**  
**36" WIDE GAS RANGE**

**INSTALLATION INSTRUCTIONS**

1. A pressure regulator sized for this unit is included. Natural gas 5.0" W.C., propane gas 10.0" W.C.
2. Gas line connecting to range must be 3/4" or larger. If flexible connectors are used, the inside diameter must be 3/4" or larger.
3. An adequate ventilation system is required for commercial cooking equipment. Information may be obtained by writing to the National Fire Protection Association, 1 Batterymarch Park, Quincy, MA 02269, www.NFPA.org. When writing, refer to NFPA No. 96.
4. These units are manufactured for installation in accordance with ANSZ223.1A (latest edition), National Fuel Gas Code. Copies may be obtained from The American Gas Association, 400 N Capitol St. NW, Washington, DC 20001, www.AGA.org.

5. **Clearances**

	<b>Rear</b>	<b>Sides</b>
Combustible	6"	10"
Standard Oven Non-combustible	0"	0"
Convection Oven Non-combustible	Min. 4"	0"
6. For proper combustion, install equipment on adjustable legs or casters provided with unit.

**NOTE:** In line with its policy to continually improve its product, Vulcan reserves the right to change materials and specifications without notice.

**Specify type of gas when ordering.**  
**Specify altitude when above 2,000 feet.**

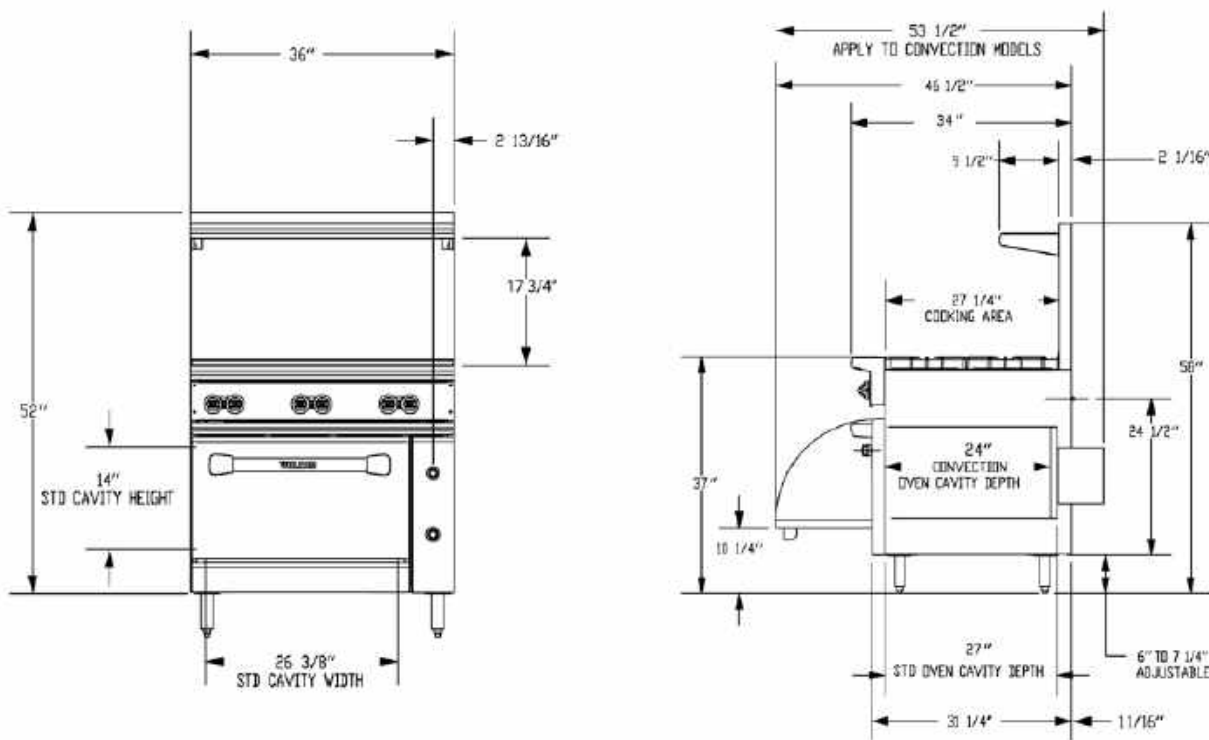

TOP CONFIGURATION	MODEL NUMBER	DESCRIPTION	TOTAL INPUT BTU / HR	SHIPPING WEIGHT LBS / KG
	<b>36S-6BN</b>	1 Standard Oven / 6 Burners / Natural Gas	215,000	520 / 236
	<b>36S-6BP</b>	1 Standard Oven / 6 Burners / Propane	215,000	520 / 236
	<b>36C-6BN</b>	1 Convection Oven / 6 Burners / Natural Gas	215,000	580 / 263
	<b>36C-6BP</b>	1 Convection Oven / 6 Burners / Propane	215,000	580 / 263

This appliance is manufactured for commercial use only and is not intended for home use.



a division of ITW Food Equipment Group LLC

P.O. Box 696 ■ Louisville, KY 40201 ■ Toll-free: 1-800-814-2028 ■ Local: 502-778-2791 ■ Quote & Order Fax: 1-800-444-0602

**NOTE:** In line with its policy to continually improve its products, Vulcan reserves the right to change materials and specifications without notice.

## Engineering Specification

Job Name \_\_\_\_\_ Contractor \_\_\_\_\_  
 Job Location \_\_\_\_\_ Approval \_\_\_\_\_  
 Engineer \_\_\_\_\_ Contractor's P.O. No. \_\_\_\_\_  
 Approval \_\_\_\_\_ Representative \_\_\_\_\_  
 SKU \_\_\_\_\_

# SnapFast® Quick-Disconnect Assemblies

Sizes: ½" to 1¼"

SnapFast Quick-Disconnect Assemblies feature flexible movement and the one-handed quick-disconnect fitting with a unique thermal shut-off design that automatically shuts off the gas when the internal temperature exceeds 350°F (177°C).

## Features

### SnapFast® One-Handed Quick-Disconnect

Quick-Disconnect .....	Brass body, aluminum collar
Thermal Shut-off .....	Shuts off gas when internal temperatures exceed 350°F (177°C)

### Additional Components

Restraining Device .....	PVC coated, steel multi-strand cable and mounting hardware
Valve .....	Full port, brass body
Elbow .....	Malleable iron
*Deluxe Kits Include .....	The Dormont Blue Hose, valve, restraining device, elbows, SnapFast, display box

## Specifications

### The Dormont Blue Hose®

Tubing .....	Annealed, 304 stainless steel
Braiding .....	Multi-strand, stainless steel wire
Coating .....	Blue antimicrobial PVC, melts at 350°F (177°C); coating will not hold a flame
End Fittings.....	Carbon steel; zinc trivalent chromate
Stress Guard®.....	360° rotational end fitting at both ends

**Safety System™** The Dormont Safety System™ is the first and only complete gas equipment connection system specifically engineered for the commercial kitchen. The Safety System consists of the famous Dormont Blue Hose and a variety of accessories designed for improved safety and performance in commercial kitchens. Because they are manufactured in the USA under an ISO qualified production process and to multiple design certifications, you can Connect with Confidence with the Dormont Safety System.

### NOTICE

The information contained herein is not intended to replace the full product installation and safety information available or the experience of a trained product installer. You are required to thoroughly read all installation instructions and product safety information before beginning the installation of this product.

Dormont product specifications in U.S. customary units and metric are approximate and are provided for reference only. For precise measurements, please contact Dormont Technical Service. Dormont reserves the right to change or modify product design, construction, specifications, or materials without prior notice and without incurring any obligation to make such changes and modifications on Dormont products previously or subsequently sold. Refer to the owner's manual for warranty information.



**Dormont®**  
 A WATTS Brand



## Approvals & Certifications



NSF/ANSI 169 – Special-purpose food equipment and devices

ANSI Z21.69 / CSA 6.16 – Connectors for moveable gas appliances

ANSI Z21.41 / CSA 6.9 – Quick-disconnect devices for use with gas fuel appliances

ANSI Z21.15 / CSA 9.1 – Manually operated gas valves for appliances, appliance connectors

Meets requirements of ANSI Z223.1 / NFPA 54 National Fuel Gas Code

Not for use in temperatures less than 32°F (0°C). For indoor use only.

Max operating pressure 1/2 psi.

Refer to the catalog for additional approvals and certifications or go to [www.dormont.com](http://www.dormont.com).

**A restraining device is required for all moveable gas equipment.**

## SnapFast® Quick-Disconnect Deluxe Kit Assembly

### Ordering Information

CONFIGURATION	SIZE I.D.	24" (607MM)	36" (914MM)	48" (1,219MM)	60" (1,524MM)	72" (1,829MM)
Deluxe Kit*	½"	1650KIT24	1650KIT36	1650KIT48	1650KIT60	1650KIT72
Basic Kit**		1650BPQR24	1650BPQR36	1650BPQR48	1650BPQR60	1650BPQR72
Hose Assembly***		1650BPQ24	1650BPQ36	1650BPQ48	1650BPQ60	1650BPQ72
Deluxe Kit*	¾"	1675KIT24	1675KIT36	1675KIT48	1675KIT60	1675KIT72
Basic Kit**		1675BPQR24	1675BPQR36	1675BPQR48	1675BPQR60	1675BPQR72
Hose Assembly***		1675BPQ24	1675BPQ36	1675BPQ48	1675BPQ60	1675BPQ72
Deluxe Kit*	1"	16100KIT24	16100KIT36	16100KIT48	16100KIT60	16100KIT72
Basic Kit**		16100BPQR24	16100BPQR36	16100BPQR48	16100BPQR60	16100BPQR72
Hose Assembly***		16100BPQ24	16100BPQ36	16100BPQ48	16100BPQ60	16100BPQ72
Deluxe Kit*	1¼"	16125KIT24	16125KIT36	16125KIT48	16125KIT60	16125KIT72
Basic Kit**		16125BPQR24	16125BPQR36	16125BPQR48	16125BPQR60	16125BPQR72
Hose Assembly***		16125BPQ24	16125BPQ36	16125BPQ48	16125BPQ60	16125BPQ72

### BTU/hr Flow Capacity Natural Gas

(Flow rating BTU/hr 0.64 SP. GR. @ 0.5 inch WC pressure drop)

MODEL	SIZE I.D.	LENGTH				
		24" (607MM)	36" (914MM)	48" (1,219MM)	60" (1,524MM)	72" (1,829MM)
1650BPQ	½"	87,000	77,000	68,000	60,000	55,000
1675BPQ	¾"	232,000	218,000	180,000	158,000	139,000
16100BPQ	1"	414,000	379,000	334,000	294,000	279,000
16125BPQ	1¼"	699,000	615,000	541,000	476,000	419,000

\* **Deluxe Kits include:** The Dormont Blue Hose and restraining device, full port valve and (2) street elbows

\*\***Basic Kits include:** The Dormont Blue Hose and restraining device, street elbow and SnapFast

\*\*\***Hose Assemblies include:** The Dormont Blue Hose, SnapFast and street elbow

## Typical Installation



## Options

### The Dormont Blue Hose®

The Dormont Blue Hose is a commercial, moveable-grade gas connector designed for use with moveable equipment.

Moveable equipment is defined in ANSI Standard Z21.69/CSA 6.16 as gas utilization equipment that may be mounted on casters or otherwise be subject to movement.



- One-handed quick-disconnect fitting
- Thermal shut-off when internal temperature exceeds 350°F (177°C)



### Restraining Device

- ANSI Z21.69 Standard section 1.7.4 states: Connectors when used on caster-mounted equipment shall be installed with a restraining device, which prevents transmission of the strain to the connector



**We guarantee our commercial gas connectors for the life of the original appliance to which it is connected.**

### Safety-Set®

#### Benefits

- Can be used with all caster-mounted equipment including cooking appliances, warming carts, salad bars, and refrigerators
- Crush Resistant
- Resistant to oils and greases
- Open-floor design allows appliance to rest level on the floor to ensure even cooking



#### Features

- Compatible with 4", 5", and 6" casters
- Certified to NSF/ANSI Standard 169 – Special Purpose Food Equipment & Devices
- Flexible, tough injection molded Thermoplastic Polyurethane (TPU)
- Able to withstand 1,000 PSI of crush pressure

#### Ordering Instructions:

The Safety-Set wheel positioning product can be ordered individually or with the Blue Hose Kit.

The Safety-Set model name is "PS" and the ordering number is 0241002.

When ordering the Safety-Set with the Blue Hose kit, simply add the letters "PS" to the end of the model number.

# Dormont®

A WATTS Brand

USA: T: (800) 367-6668 • F: (724) 733-4808 • Dormont.com





## STAFF REPORT

**Report To:** Board of Supervisors

**Meeting Date:** March 2, 2023

**Staff Contact:** Carol Akers Purchasing & Contracts Administrator and Undersheriff Jerome Tushbant

**Agenda Title:** For Possible Action: Discussion and possible action regarding Contract No. 23300294 with Mission Critical Partners to provide consulting services for replacing the Tiburon Computer Aided Dispatch System, Records Management System and Jail Management System ("CAD/RMS/JMS") for a not to exceed amount of \$165,191, to be funded by the 911 Surcharge Fund. (Carol Akers, cakers@carson.org and Undersheriff Jerome Tushbant, jtushbant@carson.org)

Staff Summary: Carson City has used Mission Critical Partners for several CAD projects. With funding approved by the 911 Surcharge Advisory Committee, this consultant may provide services including product selection, procurement, cutover and interoperability for the new CAD/RMS/JMS system.

**Agenda Action:** Formal Action / Motion

**Time Requested:** Consent

### Proposed Motion

I move to approve the contract as presented.

### Board's Strategic Goal

Efficient Government

### Previous Action

January 24, 2023 (Item 7): The 911 Surcharge Advisory Committee approved expenditure of \$171,220 for MPC consultation services.

### Background/Issues & Analysis

Since 2002, the Carson City Sheriff's Office ("CCSO") has used Tiburon as the CAD/RMS/JMS system for Carson City. CAD/RMS/JMS systems are critical to both routine and emergency operations. The technology and infrastructure of the current system, Tiburon, was designed in the late 1990s and the system is coming to the end of its life. Since its inception, Tiburon has been absorbed multiple times into a parent company. It has been CCSO's experience that as a product sunsets, the company servicing the product is not responsive or supportive. Although the most basic functions of the City's CAD/RMS/JMS needs are being achieved, there are significant problems with the Tiburon system: (a) the vendor is difficult to reach and legacy staff is limited; (b) there is no opportunity for growth or improvement of the system, even as regulations and technology impose mandates for improved systems and services; (c) there are significant process inefficiencies that cannot be addressed; and (d) costs are building to maintain the aging infrastructure and ensure interoperability with modern data-sharing solutions.

Seeking a new CAD/RMS/JMS requires research to determine needs, vendor reputation, future trends and intimate knowledge of the industry and players. This is a multi-year, multi-million-dollar project where a critical mistake could be costly in both time and money. In conference with the Carson City Manager's Office and

Information Technology Department (“CCIT”), the CCSO is seeking the assistance of a consultant to assist with this process. Mission Critical Partners has been selected for this task, and the proposal is included in the proposed contract.

Part of the consulting services that Mission Critical Partners will be performing is to evaluate Carson City’s current and future needs and match those needs with possible solutions. Thus, the precise path forward has yet to be determined and Mission Critical Partners has agreed to four phases of the project with eight milestones (see page 44 of the “Assessment and Procurement Support” document, Exhibit A to the contract). Payment will become due as the project proceeds through the phases. Some services may not be needed depending on the decisions and findings of the initial needs analysis and the consultation process. Consultant travel may be reduced or eliminated depending on the selection process. The amount of \$171,220 was approved by the 911 Surcharge Advisory Committee for this contract based on a prior quote. The amount of the proposed contract is \$165,191.

**Applicable Statute, Code, Policy, Rule or Regulation**

NRS 244A.7643 and 332.115 (1)(b), (h)

**Financial Information**

**Is there a fiscal impact?** Yes

**If yes, account name/number:** 911 Surcharge Fund Professional Services / 2872040-500309  
911 Surcharge Fund Undesignated Account / 2872040-500699

**Is it currently budgeted?** Yes

**Explanation of Fiscal Impact:** Account# 2872040-500309 will be reduced by a not to exceed amount of \$165,191. The available amount approved for consulting services by the 911 Surcharge Advisory Commission is \$171,220. At this time it is not clear if that entire amount will be used. The current available budget is \$169,695. If additional funds are needed, they can be transferred from the undesignated account 2872040-500699.

**Alternatives**

Do not approve the contract and/or provide alternate direction to staff.

**Attachments:**

[23300294 DRAFT Contract.pdf](#)

**Board Action Taken:**

Motion: _____	1) _____	Aye/Nay
	2) _____	_____
		_____
		_____
		_____

\_\_\_\_\_  
(Vote Recorded By)

**PROFESSIONAL SERVICES CONSULTANT AGREEMENT**  
**Contract No. 23300294**  
**Title: CAD/RMS/JMS Assessment and Procurement Support**

THIS CONTRACT is made and entered into this 2nd day of March 2023, by and between Carson City, a consolidated municipality, a political subdivision of the State of Nevada, hereinafter referred to as “CITY”, and Mission Critical Partners, LLC, hereinafter referred to as “CONSULTANT”.

**WITNESSETH:**

**WHEREAS**, the Purchasing and Contracts Manager for **CITY** is authorized pursuant to Nevada Revised Statutes (hereinafter referred to as “NRS”) 332 and 338 and Carson City Purchasing Resolution #1990-R71, to approve and accept this Contract as set forth in and by the following provisions; and

**WHEREAS**, this Contract (does involve \_\_\_) (does not involve X) a “public work” construction project, which pursuant to NRS 338.010(18) means any project for the new construction, repair or reconstruction of an applicable project financed in whole or in part from public money; and

**WHEREAS, CONSULTANT’S** compensation under this agreement (does \_\_\_) (does not X) utilize in whole or in part money derived from one or more federal grant funding source(s); and

**WHEREAS**, it is deemed necessary that the services of **CONSULTANT** for **CONTRACT No. 23300294** (hereinafter referred to as “Contract”) are both necessary and in the best interest of **CITY**; and

**NOW, THEREFORE**, in consideration of the aforesaid premises, and the following terms, conditions and other valuable consideration, the parties mutually agree as follows:

**1. REQUIRED APPROVAL:**

This Contract shall not become effective until and unless approved by the Carson City Board of Supervisors and all required documents are received and signed by all parties.

**2. SCOPE OF WORK (Incorporated Contract Documents):**

2.1 **CONSULTANT** shall provide and perform the following services set forth in Exhibit A, which shall all be attached hereto and incorporated herein by reference for and on behalf of **CITY** and hereinafter referred to as the “SERVICES”.

2.2 **CONSULTANT** represents that it is duly licensed by **CITY** for the purposes of performing the SERVICES.

2.3 **CONSULTANT** represents that it is duly qualified and licensed in the State of Nevada for the purposes of performing the SERVICES.

For P&C Use Only	
CCBL expires	_____
GL expires	_____
AL expires	_____
PL expires	_____
WC expires	_____

# PROFESSIONAL SERVICES CONSULTANT AGREEMENT

Contract No. 23300294

Title: CAD/RMS/JMS Assessment and Procurement Support

2.4 **CONSULTANT** represents that it and/or the persons it may employ possess all skills and training necessary to perform the SERVICES described herein and required hereunder. **CONSULTANT** shall perform the SERVICES faithfully, diligently, in a timely and professional manner, to the best of its ability, and in such a manner as is customarily performed by a person who is in the business of providing such services in similar circumstances. **CONSULTANT** shall be responsible for the professional quality and technical accuracy of all SERVICES furnished by **CONSULTANT** to **CITY**.

2.5 **CONSULTANT** represents that neither the execution of this Contract nor the rendering of services by **CONSULTANT** hereunder will violate the provisions of or constitute a default under any other contract or agreement to which **CONSULTANT** is a party or by which **CONSULTANT** is bound, or which would preclude **CONSULTANT** from performing the SERVICES required of **CONSULTANT** hereunder, or which would impose any liability or obligation upon **CITY** for accepting such SERVICES.

2.6 Before commencing with the performance of any work under this Contract, **CONSULTANT** shall obtain all necessary permits and licenses as may be necessary. Before and during the progress of work under this Contract, **CONSULTANT** shall give all notice and comply with all the laws, ordinances, rules and regulations of every kind and nature now or hereafter in effect promulgated by any Federal, State, County, or other Governmental Authority, relating to the performance of work under this Contract. If **CONSULTANT** performs any work that is contrary to any such law, ordinance, rule or regulation, it shall bear all the costs arising therefrom.

2.7 Special Terms and Conditions for Engineers, Architects, and Land Surveying/Testing:  
**(OMITTED)**

2.8 CITY Responsibilities:

2.8.1 **CITY** shall make available to **CONSULTANT** all technical data that is in **CITY'S** possession, reasonably required by **CONSULTANT** relating to the SERVICES.

2.8.2 **CITY** shall provide access to and make all provisions for **CONSULTANT** to enter upon public and private lands, to the fullest extent permitted by law, as reasonably required for **CONSULTANT** to perform the SERVICES.

2.8.3 **CITY** shall examine all reports, correspondence, and other documents presented by **CONSULTANT** upon request of **CITY**, and render, in writing, decisions pertaining thereto within a reasonable time so as not to delay the work of **CONSULTANT**.

2.8.4 It is expressly understood and agreed that all work done by **CONSULTANT** shall be subject to inspection and acceptance by **CITY** and approval of SERVICES shall not forfeit the right of **CITY** to require correction, and nothing contained herein shall relieve **CONSULTANT** of the responsibility of the SERVICES required under the terms of this Contract until all SERVICES have been completed and accepted by **CITY**.

### 3. CONTRACT TERM:

3.1 The term of this Contract begins on April 1, 2023, subject to Carson City Board of Supervisors' approval (anticipated to be March 2, 2023) and ends on October 31, 2023, unless sooner terminated by either party as specified in **Section 7** (CONTRACT TERMINATION).

**PROFESSIONAL SERVICES CONSULTANT AGREEMENT**  
**Contract No. 23300294**  
**Title: CAD/RMS/JMS Assessment and Procurement Support**

**4. NOTICE:**

4.1 Except any applicable bid and award process where notices may be limited to postings by **CITY** on its Bid Opportunities website ([www.carson.org](http://www.carson.org)), all notices or other communications required or permitted to be given under this Contract shall be in writing and shall be deemed to have been duly given if delivered personally in hand, by e-mail, by regular mail, by telephonic facsimile with simultaneous regular mail, or by certified mail, return receipt requested, postage prepaid on the date posted, and addressed to the other party at the address specified below.

4.2 Notice to **CONSULTANT** shall be addressed to:

Darrin Reilly, CEO  
Mission Critical Partners, LLC  
690 Grays Woods Blvd.  
Port Matilda, PA 16870  
814-931-4899  
[darrinreilly@missioncriticalpartners.com](mailto:darrinreilly@missioncriticalpartners.com)

4.3 Notice to **CITY** shall be addressed to:

Carson City Purchasing and Contracts Department  
Carol Akers, Purchasing and Contracts Administrator  
201 North Carson Street, Suite 2  
Carson City, NV 89701  
775-283-7362 / FAX 775-887-2286  
[CAkers@carson.org](mailto:CAkers@carson.org)

**5. COMPENSATION:**

5.1 The parties agree that **CONSULTANT** will provide the SERVICES specified in **Section 2** (SCOPE OF WORK) and **CITY** agrees to pay **CONSULTANT** the Contract's compensation based upon the Scope of Work Fee Schedule for a not to exceed maximum amount of One Hundred Sixty Five Thousand One Hundred Ninety One Dollars and 00/100 (\$165,191.00), and hereinafter referred to as "Contract Sum".

5.2 Contract Sum represents full and adequate compensation for the completed SERVICES, and includes the furnishing of all materials; all labor, equipment, tools, and appliances; and all expenses, direct or indirect, connected with the proper execution of the SERVICES.

5.3 **CITY** has provided a sample invoice and **CONSULTANT** shall submit its request for payment using said sample invoice.

5.4 Payment by **CITY** for the SERVICES rendered by **CONSULTANT** shall be due within thirty (30) calendar days from the date **CITY** acknowledges that the performance meets the requirements of this Contract or from the date the correct, complete, and descriptive invoice is received by **CITY** employee designated on the sample invoice, whichever is the later date.

5.5 **CITY** does not agree to reimburse **CONSULTANT** for expenses unless otherwise specified.

**6. TIMELINESS OF BILLING SUBMISSION:**

# PROFESSIONAL SERVICES CONSULTANT AGREEMENT

Contract No. 23300294

Title: CAD/RMS/JMS Assessment and Procurement Support

6.1 The parties agree that timeliness of billing is of the essence to this Contract and recognize that **CITY** is on a fiscal year which is defined as the period beginning July 1 and ending June 30 of the following year. All billings for dates of service prior to July 1 must be submitted to **CITY** no later than the first Friday in August of the same year. A billing submitted after the first Friday in August will subject **CONSULTANT** to an administrative fee not to exceed \$100.00. The parties hereby agree this is a reasonable estimate of the additional costs to **CITY** of processing the billing as a stale claim and that this amount will be deducted from the stale claim payment due to **CONSULTANT**.

## 7. CONTRACT TERMINATION:

### 7.1 Termination Without Cause:

7.1.1 Any discretionary or vested right of renewal notwithstanding, this Contract may be terminated upon written notice by mutual consent of both parties or unilaterally by either party without cause.

7.1.2 **CITY** reserves the right to terminate this Contract for convenience whenever it considers termination, in its sole and unfettered discretion, to be in the public interest. In the event that the Contract is terminated in this manner, payment will be made for SERVICES actually completed. If termination occurs under this provision, in no event shall **CONSULTANT** be entitled to anticipated profits on items of SERVICES not performed as of the effective date of the termination or compensation for any other item, including but not limited to, unabsorbed overhead. **CONSULTANT** shall require that all subcontracts which it enters related to this Contract likewise contain a termination for convenience clause which precludes the ability of any subcontractant to make claims against **CONSULTANT** for damages due to breach of contract, of lost profit on items of SERVICES not performed or of unabsorbed overhead, in the event of a convenience termination.

### 7.2 Termination for Nonappropriation:

7.2.1 All payments and SERVICES provided under this Contract are contingent upon the availability of the necessary public funding, which may include various internal and external sources. In the event that Carson City does not acquire and appropriate the funding necessary to perform in accordance with the terms of the Contract, the Contract shall automatically terminate upon **CITY'S** notice to **CONSULTANT** of such nonappropriation, and no claim or cause of action may be based upon any such nonappropriation.

### 7.3 Cause Termination for Default or Breach:

7.3.1 A default or breach may be declared with or without termination.

7.3.2 This Contract may be terminated by either party upon written notice of default or breach to the other party as follows:

7.3.2.1 If **CONSULTANT** fails to provide or satisfactorily perform any of the conditions, work, deliverables, goods, or any SERVICES called for by this Contract within the time requirements specified in this Contract or within any granted extension of those time requirements; or

7.3.2.2 If any state, county, city or federal license, authorization, waiver, permit, qualification or certification required by statute, ordinance, law, or regulation to be held by **CONSULTANT** to provide the goods or SERVICES or any services required by this

## PROFESSIONAL SERVICES CONSULTANT AGREEMENT

Contract No. 23300294

### Title: CAD/RMS/JMS Assessment and Procurement Support

Contract is for any reason denied, revoked, debarred, excluded, terminated, suspended, lapsed, or not renewed; or

7.3.2.3 If **CONSULTANT** becomes insolvent, subject to receivership, or becomes voluntarily or involuntarily subject to the jurisdiction of the bankruptcy court; or

7.3.2.4 If **CITY** materially breaches any material duty under this Contract and any such breach impairs **CONSULTANT'S** ability to perform; or

7.3.2.5 If it is found by **CITY** that any quid pro quo or gratuities in the form of money, services, entertainment, gifts, or otherwise were offered or given by **CONSULTANT**, or any agent or representative of **CONSULTANT**, to any officer or employee of **CITY** with a view toward securing a contract or securing favorable treatment with respect to awarding, extending, amending, or making any determination with respect to the performing of such contract; or

7.3.2.6 If it is found by **CITY** that **CONSULTANT** has failed to disclose any material conflict of interest relative to the performance of this Contract.

#### 7.4 Time to Correct (Declared Default or Breach):

7.4.1 Termination upon a declared default or breach may be exercised only after providing 7 (seven) calendar days written notice of default or breach, and the subsequent failure of the defaulting or breaching party, within five (5) calendar days of providing that default or breach notice, to provide evidence satisfactory to the aggrieved party demonstrating that the declared default or breach has been corrected. Time to correct shall run concurrently with any notice of default or breach and such time to correct is not subject to any stay with respect to the nonexistence of any Notice of Termination. Untimely correction shall not void the right to termination otherwise properly noticed unless waiver of the noticed default or breach is expressly provided in writing by the aggrieved party. There shall be no time to correct with respect to any notice of termination without cause or termination for nonappropriation.

#### 7.5 Winding Up Affairs Upon Termination:

7.5.1 In the event of termination of this Contract for any reason, the parties agree that the provisions of this **Subsection 7.5** (Winding Up Affairs Upon Termination) survive termination:

7.5.1.1 The parties shall account for and properly present to each other all claims for fees and expenses and pay those which are undisputed and otherwise not subject to set off under this Contract. Neither party may withhold performance of winding up provisions solely based on nonpayment of fees or expenses accrued up to the time of termination; and

7.5.1.2 **CONSULTANT** shall satisfactorily complete SERVICES in progress at the agreed rate (or a pro rata basis if necessary) if so requested by **CITY**; and

7.5.1.3 **CONSULTANT** shall execute any documents and take any actions necessary to effectuate an assignment of this Contract if so requested by **CITY**; and

7.5.1.4 **CONSULTANT** shall preserve, protect, and promptly deliver into **CITY** possession all proprietary information in accordance **Section 19** (CITY OWNERSHIP OF PROPRIETARY INFORMATION).

# PROFESSIONAL SERVICES CONSULTANT AGREEMENT

Contract No. 23300294

Title: CAD/RMS/JMS Assessment and Procurement Support

## 7.6 Notice of Termination:

7.6.1 Unless otherwise specified in this Contract, termination shall not be effective until seven (7) calendar days after a party has provided written notice of default or breach, or notice of without cause termination. Notice of Termination may be given at the time of notice of default or breach, or notice of without cause termination. Notice of Termination may be provided separately at any time after the running of the 7-day notice period, and such termination shall be effective on the date the Notice of Termination is provided to the party unless a specific effective date is otherwise set forth therein. Any delay in providing a Notice of Termination after the 7-day notice period has run without a timely correction by the defaulting or breaching party shall not constitute any waiver of the right to terminate under the existing notice(s).

## 8. REMEDIES:

Except as otherwise provided for by law or this Contract, the rights and remedies of the parties shall not be exclusive and are in addition to any other rights and remedies provided by law or equity, including, without limitation, actual damages, and to a prevailing party reasonable attorney's fees and costs. The parties agree that, in the event a lawsuit is filed and a party is awarded attorney's fees by the court, for any reason, the amount of recoverable attorney's fees shall not exceed the rate of \$125 per hour. CITY may set off consideration against any unpaid obligation of CONSULTANT to CITY.

## 9. LIMITED LIABILITY:

CITY will not waive and intends to assert available NRS Chapter 41 liability limitations in all cases. Contract liability of both parties shall not be subject to punitive damages. Liquidated damages shall not apply unless otherwise expressly provided for elsewhere in this Contract. Damages for any CITY breach shall never exceed the amount of funds appropriated for payment under this Contract, but not yet paid to CONSULTANT, for the fiscal year budget in existence at the time of the breach. CONSULTANT'S tort liability shall not be limited.

## 10. FORCE MAJEURE:

Neither party shall be deemed to be in violation of this Contract if it is prevented from performing any of its obligations hereunder due to strikes, failure of public transportation, civil or military authority, act of public enemy, accidents, fires, explosions, or acts of God, including, without limitation, earthquakes, floods, winds, or storms. In such an event the intervening cause must not be through the fault of the party asserting such an excuse, and the excused party is obligated to promptly perform in accordance with the terms of this Contract after the intervening cause ceases.

## 11. INDEMNIFICATION:

11.1 To the extent permitted by law, including, but not limited to, the provisions of NRS Chapter 41, each party shall indemnify, hold harmless and defend, not excluding the other's right to participate, the other party from and against all liability, claims, actions, damages, losses, and expenses, including but not limited to reasonable attorney's fees and costs, arising out of any alleged negligent or willful acts or omissions of the indemnifying party, its officers, employees and agents. Such obligation shall not be construed to negate, abridge, or otherwise reduce any other right or obligation of the indemnity which would otherwise exist as to any party or person described in this Section.

11.2 As required by NRS 338.155, if this Contract involves a "public work" construction project as defined above, CONSULTANT shall defend, indemnify and hold harmless the CITY, and the employees, officers and agents of the public body from any liabilities, damages, losses, claims, actions or proceedings, including without limitation, reasonable attorney's fees, to the extent that such liabilities, damages, losses, claims, actions or proceedings are caused by the negligence, errors, omissions, recklessness or intentional misconduct of the CONSULTANT or the employees or agents of the CONSULTANT in the performance of the Contract. Such obligation shall not be construed to negate, abridge, or otherwise reduce any other right or obligation of the indemnity which would otherwise exist as



# PROFESSIONAL SERVICES CONSULTANT AGREEMENT

Contract No. 23300294

## Title: CAD/RMS/JMS Assessment and Procurement Support

to any party or person described in this section. However, with respect to any anticipated benefits to **CITY** resulting from the Scope of Work, **CONSULTANT** shall not be responsible or liable to **CITY** for any warranties, guarantees, fitness for a particular purpose or loss of anticipated profits resulting from any termination of this Contract. Additionally, **CONSULTANT** shall not be responsible for acts and decisions of third parties, including governmental agencies, other than **CONSULTANT'S** subcontractors, that impact project completion and/or success.

11.3 Except as otherwise provided in Subsection 11.5 below, the indemnifying party shall not be obligated to provide a legal defense to the indemnified party, nor reimburse the indemnified party for the same, for any period occurring before the indemnified party provides written notice of the pending claim(s) or cause(s) of action to the indemnifying party, along with:

11.3.1 a written request for a legal defense for such pending claim(s) or cause(s) of action; and

11.3.2 a detailed explanation of the basis upon which the indemnified party believes that the claim or cause of action asserted against the indemnified party implicates the culpable conduct of the indemnifying party, its officers, employees, and/or agents.

11.4 After the indemnifying party has begun to provide a legal defense for the indemnified party, the indemnifying party shall not be obligated to fund or reimburse any fees or costs provided by any additional counsel for the indemnified party, including counsel through which the indemnified party might voluntarily choose to participate in its defense of the same matter.

11.5 After the indemnifying party has begun to provide a legal defense for the indemnified party, the indemnifying party shall be obligated to reimburse the reasonable attorney's fees and costs incurred by the indemnified party during the initial thirty (30) day period of the claim or cause of action, if any, incurred by separate counsel.

## 12. INDEPENDENT CONTRACTOR:

12.1 **CONSULTANT**, as an independent contractor, is a natural person, firm or corporation who agrees to perform SERVICES for a fixed price according to his or its own methods and without subjection to the supervision or control of the **CITY**, except as to the results of the SERVICES, and not as to the means by which the SERVICES are accomplished.

12.2 It is mutually agreed that **CONSULTANT** is associated with **CITY** only for the purposes and to the extent specified in this Contract, and in respect to performance of the contracted SERVICES pursuant to this Contract. **CONSULTANT** is and shall be an independent contractor and, subject only to the terms of this Contract, shall have the sole right to supervise, manage, operate, control, and direct performance of the details incident to its duties under this Contract.

12.3 Nothing contained in this Contract shall be deemed or construed to create a partnership or joint venture, to create relationships of an employer-employee or principal-agent, or to otherwise create any liability for **CITY** whatsoever with respect to the indebtedness, liabilities, and obligations of **CONSULTANT** or any other party.

12.4 **CONSULTANT**, in addition to Section 11 (INDEMNIFICATION), shall indemnify and hold **CITY** harmless from, and defend **CITY** against, any and all losses, damages, claims, costs, penalties, liabilities, expenses arising out of or incurred in any way because of, but not limited to, **CONSULTANT'S** obligations or legal duties regarding any taxes, fees, assessments, benefits, entitlements, notice of benefits, employee's eligibility to work, to any third party, subcontractor, employee, state, local or federal governmental entity.

12.5 Neither **CONSULTANT** nor its employees, agents, or representatives shall be considered employees, agents, or representatives of **CITY**.

## 13. INSURANCE REQUIREMENTS (GENERAL):

## PROFESSIONAL SERVICES CONSULTANT AGREEMENT

Contract No. 23300294

Title: CAD/RMS/JMS Assessment and Procurement Support

**13.1 NOTICE: The following general insurance requirements shall apply unless these general requirements are altered by any specific requirements set forth in CITY'S solicitation for bid document, the adopted bid or other document incorporated into this Contract by the parties.**

13.2 **CONSULTANT**, as an independent contractor and not an employee of **CITY**, must carry policies of insurance in amounts specified and pay all taxes and fees incident hereunto. **CITY** shall have no liability except as specifically provided in this Contract.

13.3 **CONSULTANT** shall not commence work before: (1) **CONSULTANT** has provided the required evidence of insurance to **CITY** Purchasing and Contracts, and (2) **CITY** has approved the insurance policies provided by **CONSULTANT**.

13.4 Prior approval of the insurance policies by **CITY** shall be a condition precedent to any payment of consideration under this Contract and **CITY'S** approval of any changes to insurance coverage during the course of performance shall constitute an ongoing condition subsequent this Contract. Any failure of **CITY** to timely approve shall not constitute a waiver of the condition.

13.5 *Insurance Coverage (13.6 through 13.23):*

13.6 **CONSULTANT** shall, at **CONSULTANT'S** sole expense, procure, maintain and keep in force for the duration of this Contract the following insurance conforming to the minimum requirements specified below. Unless specifically specified herein or otherwise agreed to by **CITY**, the required insurance shall be in effect prior to the commencement of work by **CONSULTANT** and shall continue in force as appropriate until the later of:

13.6.1 Final acceptance by **CITY** of the completion of this Contract; or

13.6.2 Such time as the insurance is no longer required by **CITY** under the terms of this Contract.

13.6.3 Any insurance or self-insurance available to **CITY** under its coverage(s) shall be in excess of and non-contributing with any insurance required from **CONSULTANT**. **CONSULTANT'S** insurance policies shall apply on a primary basis. Until such time as the insurance is no longer required by **CITY**, **CONSULTANT** shall provide **CITY** with renewal or replacement evidence of insurance no less than thirty (30) calendar days before the expiration or replacement of the required insurance. If at any time during the period when insurance is required by this Contract, an insurer or surety shall fail to comply with the requirements of this Contract, as soon as **CONSULTANT** has knowledge of any such failure, **CONSULTANT** shall immediately notify **CITY** and immediately replace such insurance or bond with an insurer meeting the requirements.

13.7 *General Insurance Requirements (13.8 through 13.23):*

13.8 **Certificate Holder:** Each liability insurance policy shall list Carson City c/o Carson City Purchasing and Contracts, 201 N. Carson Street, Suite 2, Carson City, NV 89701 as a certificate holder.

13.9 **Additional Insured:** By endorsement to the general liability insurance policy evidenced by **CONSULTANT**, The City and County of Carson City, Nevada, its officers, employees and immune contractors shall be named as additional insureds for all liability arising from this Contract.

13.10 **Waiver of Subrogation:** Each liability insurance policy shall provide for a waiver of subrogation as to additional insured, unless:

13.10.1 **CONSULTANT** maintains an additional \$5,000,000.00 umbrella policy in lieu of the Waiver of Subrogation Clause.

13.11 **Cross-Liability:** All required liability policies shall provide cross-liability coverage as would be achieved under the standard ISO separation of insureds clause.

13.12 **Deductibles and Self-Insured Retentions:** Insurance maintained by **CONSULTANT** shall apply

## PROFESSIONAL SERVICES CONSULTANT AGREEMENT

Contract No. 23300294

### Title: CAD/RMS/JMS Assessment and Procurement Support

on a first dollar basis without application of a deductible or self-insured retention unless otherwise specifically agreed to by **CITY**. Such approval shall not relieve **CONSULTANT** from the obligation to pay any deductible or self-insured retention. Any deductible or self-insured retention shall not exceed \$50,000.00 per occurrence, unless otherwise approved by **CITY**.

13.13 **Policy Cancellation:** Except for ten (10) calendar days notice for non-payment of premium, each insurance policy shall be endorsed to state that; without thirty (30) calendar days prior written notice to Carson City Purchasing and Contracts, the policy shall not be canceled, non-renewed or coverage and /or limits reduced or materially altered, and shall provide that notices required by this paragraph shall be sent by mail to Carson City Purchasing and Contracts, 201 N. Carson Street, Suite 2, Carson City, NV 89701.

13.14 **Approved Insurer:** Each insurance policy shall be issued by insurance companies authorized to do business in the State of Nevada or eligible surplus lines insurers acceptable to the State and having agents in Nevada upon whom service of process may be made, and currently rated by A.M. Best as "A-VII" or better.

13.15 **Evidence of Insurance:** Prior to commencement of work, **CONSULTANT** must provide the following documents to Carson City Purchasing and Contracts, 201 North Carson Street, Suite 2, Carson City, NV 89701:

13.16 **Certificate of Insurance:** The Acord 25 Certificate of Insurance form or a form substantially similar must be submitted to Carson City Purchasing and Contracts to evidence the insurance policies and coverages required of **CONSULTANT**.

13.17 **Additional Insured Endorsement:** An Additional Insured Endorsement (CG20 10 or C20 26), signed by an authorized insurance company representative, must be submitted to Carson City Purchasing and Contracts to evidence the endorsement of **CITY** as an additional insured per **Subsection 13.9** (Additional Insured).

13.18 **Schedule of Underlying Insurance Policies:** If Umbrella or Excess policy is evidenced to comply with minimum limits, a copy of the Underlying Schedule from the Umbrella or Excess insurance policy may be required.

13.19 **Review and Approval:** Documents specified above must be submitted for review and approval by **CITY** Purchasing and Contracts prior to the commencement of work by **CONSULTANT**. Neither approval by **CITY** nor failure to disapprove the insurance furnished by **CONSULTANT** shall relieve **CONSULTANT** of **CONSULTANT'S** full responsibility to provide the insurance required by this Contract. Compliance with the insurance requirements of this Contract shall not limit the liability of **CONSULTANT** or its subcontractors, employees or agents to **CITY** or others, and shall be in addition to and not in lieu of any other remedy available to **CITY** under this Contract or otherwise. **CITY** reserves the right to request and review a copy of any required insurance policy or endorsement to assure compliance with these requirements.

#### 13.20 **COMMERCIAL GENERAL LIABILITY INSURANCE:**

13.20.1 *Minimum Limits required:*

13.20.2 Two Million Dollars (\$2,000,000.00) - General Aggregate.

13.20.3 Two Million Dollars (\$2,000,000.00) - Products & Completed Operations Aggregate.

13.20.4 One Million Dollars (\$1,000,000.00) - Each Occurrence.

13.20.5 Coverage shall be on an occurrence basis and shall be at least as broad as ISO 1996 form CG 00 01 (or a substitute form providing equivalent coverage); and shall cover liability arising from premises, operations, independent contractors, completed operations, personal injury, products, civil lawsuits, Title VII actions and liability assumed under an insured contract

**PROFESSIONAL SERVICES CONSULTANT AGREEMENT**  
**Contract No. 23300294**  
**Title: CAD/RMS/JMS Assessment and Procurement Support**

(including the tort liability of another assumed in a business contract).

**13.21 BUSINESS AUTOMOBILE LIABILITY INSURANCE:**

13.21.1 *Minimum Limit required:*

13.21.2 One Million Dollars (\$1,000,000.00) per occurrence for bodily injury and property damage.

13.21.3 Coverage shall be for "any auto", including owned, non-owned and hired vehicles. The policy shall be written on ISO form CA 00 01 or a substitute providing equivalent liability coverage. If necessary, the policy shall be endorsed to provide contractual liability coverage.

**13.22 PROFESSIONAL LIABILITY INSURANCE (Architects, Engineers and Land Surveyors)**

13.22.1 *Minimum Limit required:*

13.22.2 One Million Dollars (\$1,000,000.00).

13.22.3 Retroactive date: Prior to commencement of the performance of this Contract.

13.22.4 Discovery period: Three (3) years after termination date of this Contract.

13.22.5 A certified copy of this policy may be required.

**13.23 WORKERS' COMPENSATION AND EMPLOYER'S LIABILITY INSURANCE:**

13.23.1 **CONSULTANT** shall provide workers' compensation insurance as required by NRS Chapters 616A through 616D inclusive and Employer's Liability insurance with a minimum limit of \$500,000.00 each employee per accident for bodily injury by accident or disease.

13.23.2 **CONSULTANT** may, in lieu of furnishing a certificate of an insurer, provide an affidavit indicating that **CONSULTANT** is a sole proprietor; that **CONSULTANT** will not use the services of any employees in the performance of this Contract; that **CONSULTANT** has elected to not be included in the terms, conditions, and provisions of NRS Chapters 616A-616D, inclusive; and that **CONSULTANT** is otherwise in compliance with the terms, conditions, and provisions of NRS Chapters 616A-616D, inclusive.

**14. BUSINESS LICENSE:**

14.1 **CONSULTANT** shall not commence work before **CONSULTANT** has provided a copy of his Carson City business license to Carson City Purchasing and Contracts.

14.2 The Carson City business license shall continue in force until the later of: (1) final acceptance by **CITY** of the completion of this Contract; or (2) such time as the Carson City business license is no longer required by **CITY** under the terms of this Contract.

**15. COMPLIANCE WITH LEGAL OBLIGATIONS:**

**CONSULTANT** shall procure and maintain for the duration of this Contract any state, county, city, or federal license, authorization, waiver, permit, qualification or certification required by statute, ordinance, law, or regulation to be held by **CONSULTANT** to provide the goods or SERVICES or any services of this Contract. **CONSULTANT** will be responsible to pay all government obligations, including, but not limited to, all taxes, assessments, fees, fines, judgments, premiums, permits, and licenses required or imposed by law or a court. Real property and personal property taxes are the responsibility of **CONSULTANT** in accordance with NRS Chapter 361 generally and NRS 361.157 and 361.159, specifically regarding for profit activity. **CONSULTANT** agrees to be responsible for payment of any such government obligations not paid by its subcontractors during performance of this Contract. **CITY** may set-off against consideration due any delinquent government obligation.

**PROFESSIONAL SERVICES CONSULTANT AGREEMENT**  
**Contract No. 23300294**  
**Title: CAD/RMS/JMS Assessment and Procurement Support**

If the CITY was required by NRS 332.039(1) to advertise or request a proposal for this Agreement, by signing this Agreement, the **CONSULTANT** provides a written certification that the **CONSULTANT** is not currently engaged in, and during the Term shall not engage in, a Boycott of Israel. The term "Boycott of Israel" has the meaning ascribed to that term in Section 3 of Nevada Senate Bill 26 (2017). The **CONSULTANT** shall be responsible for fines, penalties, and payment of any State of Nevada or federal funds that may arise (including those that the CITY pays, becomes liable to pay, or becomes liable to repay) as a direct result of the **CONSULTANT's** non-compliance with this Section.

**16. WAIVER OF BREACH:**

Failure to declare a breach or the actual waiver of any particular breach of this Contract or its material or nonmaterial terms by either party shall not operate as a waiver by such party of any of its rights or remedies as to any other breach.

**17. SEVERABILITY:**

If any provision contained in this Contract is held to be unenforceable by a court of law or equity, this Contract shall be construed as if such provision did not exist and the nonenforceability of such provision shall not be held to render any other provision or provisions of this Contract unenforceable.

**18. ASSIGNMENT / DELEGATION:**

To the extent that any assignment of any right under this Contract changes the duty of either party, increases the burden or risk involved, impairs the chances of obtaining the performance of this Contract, attempts to operate as a novation, or includes a waiver or abrogation of any defense to payment by **CITY**, such offending portion of the assignment shall be void, and shall be a breach of this Contract. **CONSULTANT** shall neither assign, transfer nor delegate any rights, obligations or duties under this Contract without the prior written approval of **CITY**. The parties do not intend to benefit any third party beneficiary regarding their respective performance under this Contract.

**19. CITY OWNERSHIP OF PROPRIETARY INFORMATION:**

Any files, reports, histories, studies, tests, manuals, instructions, photographs, negatives, blue prints, plans, maps, data, system designs, computer programs, computer codes, and computer records (which are intended to be consideration under this Contract), or any other documents or drawings, prepared or in the course of preparation by **CONSULTANT** (or its subcontractors) in performance of its obligations under this Contract shall be the exclusive property of **CITY** and all such materials shall be delivered into **CITY** possession by **CONSULTANT** upon completion, termination, or cancellation of this Contract. **CONSULTANT** shall not use, willingly allow, or cause to have such materials used for any purpose other than performance of **CONSULTANT'S** obligations under this Contract without the prior written consent of **CITY**. Notwithstanding the foregoing, **CITY** shall have no proprietary interest in any materials licensed for use by **CITY** that are subject to patent, trademark or copyright protection.

**20. PUBLIC RECORDS:**

Pursuant to NRS 239.010, information or documents received from **CONSULTANT** may be open to public inspection and copying. **CITY** will have the duty to disclose unless a particular record is made confidential by law or a common law balancing of interests. **CONSULTANT** may clearly label specific parts of an individual document as a "trade secret" or "confidential" in accordance with NRS 332.061, provided that **CONSULTANT** thereby agrees to indemnify and defend **CITY** for honoring such a designation. The failure to so label any document that is released by **CITY** shall constitute a complete waiver of any and all claims for damages caused by any release of the records.

**21. CONFIDENTIALITY:**

**CONSULTANT** shall keep confidential all information, in whatever form, produced, prepared, observed or received by **CONSULTANT** to the extent that such information is confidential by law or otherwise required by this Contract.

**PROFESSIONAL SERVICES CONSULTANT AGREEMENT**  
**Contract No. 23300294**  
**Title: CAD/RMS/JMS Assessment and Procurement Support**

**22. FEDERAL FUNDING: NOT APPLICABLE FOR THIS AGREEMENT**

22.1 *In the event federal grant funds are used for payment of all or part of this Contract:*

22.1.1 **CONSULTANT** certifies, by signing this Contract, that neither it nor its principals are presently debarred, suspended, proposed for debarment, declared ineligible, or voluntarily excluded from participation in this transaction by any federal department or agency. This certification is made pursuant to the regulations implementing Executive Order 12549, Debarment and Suspension, 28 C.F.R. pt. 67, § 67.510, as published as pt. VII of the May 26, 1988, Federal Register (pp. 19160-19211), and any relevant program-specific regulations. This provision shall be required of every subcontractor receiving any payment in whole or in part from federal funds.

22.1.2 **CONSULTANT** and its subcontractors must be registered in the US Government System for Award Management (SAM) for verification on projects with federal funding.

22.1.3 **CONSULTANT** and its subcontractors shall comply with all terms, conditions, and requirements of the Americans with Disabilities Act of 1990 (P.L. 101-136), 42 U.S.C. 12101, as amended, and regulations adopted thereunder contained in 28 C.F.R. 26.101-36.999, inclusive, and any relevant program-specific regulations.

22.1.4 **CONSULTANT** and its subcontractors shall comply with the requirements of the Civil Rights Act of 1964, as amended, the Rehabilitation Act of 1973, P.L. 93-112, as amended, and any relevant program-specific regulations, and Executive Order 11478 (July 21, 2014) and shall not discriminate against any employee or offeror for employment because of race, national origin, creed, color, sex, sexual orientation, gender identity, religion, age, disability or handicap condition (including AIDS and AIDS-related conditions).

22.1.5 If and when applicable to the particular federal funding and the Scope of Work under this Contract, **CONSULTANT** and its subcontractors shall comply with: American Iron and Steel (AIS) provisions of P.L. 113- 76, Consolidated Appropriations Act, 2014, Section 1605 – Buy American (100% Domestic Content of iron, steel and manufactured goods); Federal Highway Administration (FHWA) 23 U.S.C. § 313 – Buy America, 23 C.F.R. § 635.410 (100% Domestic Content of steel, iron and manufactured products); Federal Transit Administration (FTA) 49 U.S.C. § 5323(j), 49 C.F.R. Part 661 – Buy America Requirements (See 60% Domestic Content for buses and other Rolling Stock).

**23. LOBBYING:**

23.1 The parties agree, whether expressly prohibited by federal law, or otherwise, that no funding associated with this Contract will be used for any purpose associated with or related to lobbying or influencing or attempting to lobby or influence for any purpose the following:

23.1.1 Any federal, state, county or local agency, legislature, commission, council or board;

23.1.2 Any federal, state, county or local legislator, commission member, council member, board member, or other elected official; or

23.1.3 Any officer or employee of any federal, state, county or local agency; legislature, commission, council or board.

**24. GENERAL WARRANTY:**

**CONSULTANT** warrants that it will perform all SERVICES required hereunder in accordance with the prevailing standard of care by exercising the skill and care normally required of individuals performing the same or similar

**PROFESSIONAL SERVICES CONSULTANT AGREEMENT**  
**Contract No. 23300294**  
**Title: CAD/RMS/JMS Assessment and Procurement Support**

SERVICES, under the same or similar circumstances, in the State of Nevada.

**25. PROPER AUTHORITY:**

The parties hereto represent and warrant that the person executing this Contract on behalf of each party has full power and authority to enter into this Contract. **CONSULTANT** acknowledges that this Contract is effective only after approval by the Carson City Board of Supervisors and only for the period of time specified in this Contract. Any SERVICES performed by **CONSULTANT** before this Contract is effective or after it ceases to be effective is performed at the sole risk of **CONSULTANT**.

**26. ALTERNATIVE DISPUTE RESOLUTION (Public Work):**

If the SERVICES under this Contract involve a “public work” as defined under NRS 338.010(18), then pursuant to NRS 338.150, a public body charged with the drafting of specifications for a public work shall include in the specifications a clause requiring the use of a method of alternative dispute resolution (“ADR”) before initiation of a judicial action if a dispute arising between the public body and the **CONSULTANT** engaged on the public work cannot otherwise be settled. Therefore, unless ADR is otherwise provided for by the parties in any other incorporated attachment to this Contract, in the event that a dispute arising between **CITY** and **CONSULTANT** regarding that public work cannot otherwise be settled, **CITY** and **CONSULTANT** agree that, before judicial action may be initiated, **CITY** and **CONSULTANT** will submit the dispute to non-binding mediation. **CITY** shall present **CONSULTANT** with a list of three potential mediators. **CONSULTANT** shall select one person to serve as the mediator from the list of potential mediators presented by **CITY**. The person selected as mediator shall determine the rules governing the mediation.

**27. GOVERNING LAW / JURISDICTION:**

This Contract and the rights and obligations of the parties hereto shall be governed by, and construed according to, the laws of the State of Nevada, without giving effect to any principle of conflict-of-law that would require the application of the law of any other jurisdiction. **CONSULTANT** consents and agrees to the jurisdiction of the courts of the State of Nevada located in Carson City, Nevada for enforcement of this Contract.

**28. ENTIRE CONTRACT AND MODIFICATION:**

This Contract and its integrated attachment(s) constitute the entire Contract of the parties and such are intended as a complete and exclusive statement of the promises, representations, negotiations, discussions, and other Contracts that may have been made in connection with the subject matter hereof. Unless an integrated attachment to this Contract specifically displays a mutual intent to amend a particular part of this Contract, general conflicts in language between any such attachment and this Contract shall be construed consistent with the terms of this Contract. Unless otherwise expressly authorized by the terms of this Contract, no modification or amendment to this Contract shall be binding upon the parties unless the same is in writing and signed by the respective parties hereto and approved by the Carson City Board of Supervisors. Conflicts in language between this Contract and any other agreement between **CITY** and **CONSULTANT** on this same matter shall be construed consistent with the terms of this Contract. The parties agree that each has had their respective counsel review this Contract which shall be construed as if it was jointly drafted.

**PROFESSIONAL SERVICES CONSULTANT AGREEMENT**  
**Contract No. 23300294**  
**Title: CAD/RMS/JMS Assessment and Procurement Support**

**29. ACKNOWLEDGMENT AND EXECUTION:**

This Contract may be executed in counterparts. The parties hereto have caused this Contract to be signed and intend to be legally bound thereby as follows:

**CITY**

Executive Office  
Attn: Carol Akers, Purchasing & Contracts Administrator  
Purchasing and Contracts Department  
201 North Carson Street, Suite 2  
Carson City, Nevada 89701  
Telephone: 775-283-7362  
Fax: 775-887-2286  
[CAkers@carson.org](mailto:CAkers@carson.org)

**CITY'S LEGAL COUNSEL**

Carson City District Attorney

I have reviewed this Contract and approve as to its legal form.

By: \_\_\_\_\_  
Sheri Russell-Benabou, Chief Financial Officer

By: \_\_\_\_\_  
Deputy District Attorney

Dated \_\_\_\_\_

Dated \_\_\_\_\_

**CITY'S ORIGINATING DEPARTMENT**  
**CONSULTANT will not be given authorization to begin work until this Contract has been signed by Purchasing and Contracts**

**BY:** Carol Akers

Acct: 2872040-500309

By: \_\_\_\_\_

Dated \_\_\_\_\_

**PROJECT CONTACT PERSON:**

Jerome Tushbant, Undersheriff  
Telephone: 775-283-7802  
[JTushbant@carson.org](mailto:JTushbant@carson.org)



**PROFESSIONAL SERVICES CONSULTANT AGREEMENT**  
**Contract No. 23300294**  
**Title: CAD/RMS/JMS Assessment and Procurement Support**

Undersigned deposes and says under penalty of perjury: That he/she is **CONSULTANT** or authorized agent of **CONSULTANT**; that he/she has read the foregoing Contract; and that he/she understands the terms, conditions and requirements thereof.

**CONSULTANT**

**BY:** John Spearly

**TITLE:** Director of Contracts Administration

**FIRM:** Mission Critical Partners, LLC

**CARSON CITY BUSINESS LICENSE #: BL-007833**

**Address:** 690 Grays Woods Blvd.

**City:** Port Matilda      **State:** PA      **Zip Code:** 16870

**Telephone:** 814-931-4899

**E-mail Address:** [johnspearly@missioncriticalpartners.com](mailto:johnspearly@missioncriticalpartners.com)

\_\_\_\_\_  
(Signature of Consultant)

**DATED** \_\_\_\_\_

**STATE OF** \_\_\_\_\_ )

)ss

**County of** \_\_\_\_\_ )

Signed and sworn (or affirmed before me on this \_\_\_\_\_ day of \_\_\_\_\_, 20\_\_\_\_.

\_\_\_\_\_  
(Signature of Notary)

(Notary Stamp)

**PROFESSIONAL SERVICES CONSULTANT AGREEMENT**  
**Contract No. 23300294**  
**Title: CAD/RMS/JMS Assessment and Procurement Support**

**CONTRACT ACCEPTANCE AND EXECUTION:**

The Board of Supervisors for Carson City, Nevada at their publicly noticed meeting of March 2, 2023, approved the acceptance of the attached Contract hereinbefore identified as **CONTRACT No. 23300294**. Further, the Board of Supervisors authorizes the Mayor of Carson City, Nevada to sign this document and record the signature for the execution of this Contract in accordance with the action taken.

**CARSON CITY, NEVADA**

\_\_\_\_\_  
LORI BAGWELL, MAYOR

DATED this 2nd day of March 2023.

**ATTEST:**

\_\_\_\_\_  
WILLIAM SCOTT HOEN, CLERK-RECORDER

DATED this 2nd day of March 2023.

**PROFESSIONAL SERVICES CONSULTANT AGREEMENT**  
**Contract No. 23300294**  
**Title: CAD/RMS/JMS Assessment and Procurement Support**

**SAMPLE INVOICE**

Invoice Number: \_\_\_\_\_  
 Invoice Date: \_\_\_\_\_  
 Invoice Period: \_\_\_\_\_

Invoice shall be submitted to:

Carson City Sheriff's Office  
 Attn: Casey Otto, Business Manager, email: [COtto@carson.org](mailto:COtto@carson.org)  
 911 E. Musser Street  
 Carson City NV 89701

Line Item #	Description	Unit Cost	Units Completed	Total \$\$
<b>Total for this invoice</b>				

Original Contract Sum	\$	_____
Less amount previously billed	\$	_____
= contract sum prior to this invoice	\$	_____
Less this invoice	\$	_____
=Dollars remaining on Contract	\$	_____

**ENCLOSE COPIES OF RECEIPTS & INVOICES FOR EXPENSES & OUTSIDE SERVICES**



Proposal

# CAD/RMS/JMS Assessment and Procurement Support

January 26, 2023

Carson City, NV  
Public Safety Emergency Communications Center

# Table of Contents

- Introduction Letter .....1**
- Your Mission Matters .....2**
- Statement of Services .....7**
  - Project Understanding .....8
  - Scope of Work .....9
    - Phase 1: Operational and Functional Needs Analysis and Requirements Outline ..... 9
    - Phase 2: Specification Writing/RFP Development..... 11
    - Phase 3: System Procurement Process ..... 12
    - Phase 4: Contract Negotiations (30 Hours) ..... 13
  - Optional Implementation Services .....14
    - Phase 5: System Implementation and Cutover Support ..... 14
- Project Team.....16**
  - Organizational Chart .....17
  - Resumes .....18
- Experience .....26**
  - Relevant Project Experience .....27
- Pricing .....43**
- Appendix A: The Public Safety Ecosystem and MCP Service Offerings.....46**

# Introduction Letter

January 26, 2023

Jenn Stoffer  
911 Communications Manager/TAC  
Carson City Sheriff's Office  
201 N. Carson St.  
Carson City, NV 89701

Re: Proposal for CAD/RMS/JMS Assessment and Procurement Support

Dear Ms. Stoffer:

Mission Critical Partners, LLC (MCP) appreciates the opportunity to provide the Carson City Public Safety Emergency Communications Center (Center) with a proposal for computer-aided dispatch (CAD), record management system (RMS), and jail management system (JMS) assessment and procurement support.

MCP is prepared to serve the Center by assisting with achieving optimal delivery of emergency communications and systems-related services. If you have any questions regarding the information submitted, please contact me at 415.302.4866, or via email at [BretHubbard@MissionCriticalPartners.com](mailto:BretHubbard@MissionCriticalPartners.com).

On behalf of our entire team, we stand behind the Carson City Public Safety Emergency Communications Center to serve as your partner and your advocate.

Sincerely,

Mission Critical Partners, LLC



Bret Hubbard  
Client Services Director



## Your Mission Matters

### At MCP, Our Mission Is Simple: To Improve Emergency Response and Justice Outcomes

We are committed to working collaboratively with you to implement successful solutions for your networks, data, and operations. More than just a consultant, we act as trusted advisors to our clients, striving to deliver value, efficiency, and fresh ideas—all while mitigating risk. We are solely focused on the public safety, justice, healthcare and critical communications sectors, and what makes us different is our holistic perspective. A leading provider of data integration, consulting, network and cybersecurity services, our vision is to transform the mission-critical communications and public-sector networks and operations into integrated ecosystems.

More importantly, we stand behind the significance of the work our clients do and how critical their missions are—not just for their organizations, but because their communities are counting on them. While we are proud to have the largest, most experienced team of specialized experts in the industry, our greatest pride comes from applying this expertise to work side by side with our clients to implement the best possible solutions—because the mission matters.

### By the Numbers



Since 2009, MCP has supported 3,200+ projects for 1,300+ public-sector and critical communications agencies



We serve clients in 48 states and 95% of the nation's largest metropolitan areas



Our staff consists of 200+ subject-matter experts, each with an average of 25 years of experience, dedicated to supporting our clients and their missions



We create significant project cost savings for our clients—often 15%, sometimes more



More than 90% of our clients remain with us from project to project

# Nationwide Expertise, Local Insight

## Turning Client Goals into Reality

With satellite offices, subject-matter experts, and project managers located across the country, MCP can deliver the right team, with the right experience and expertise, to every client, anywhere in the country.

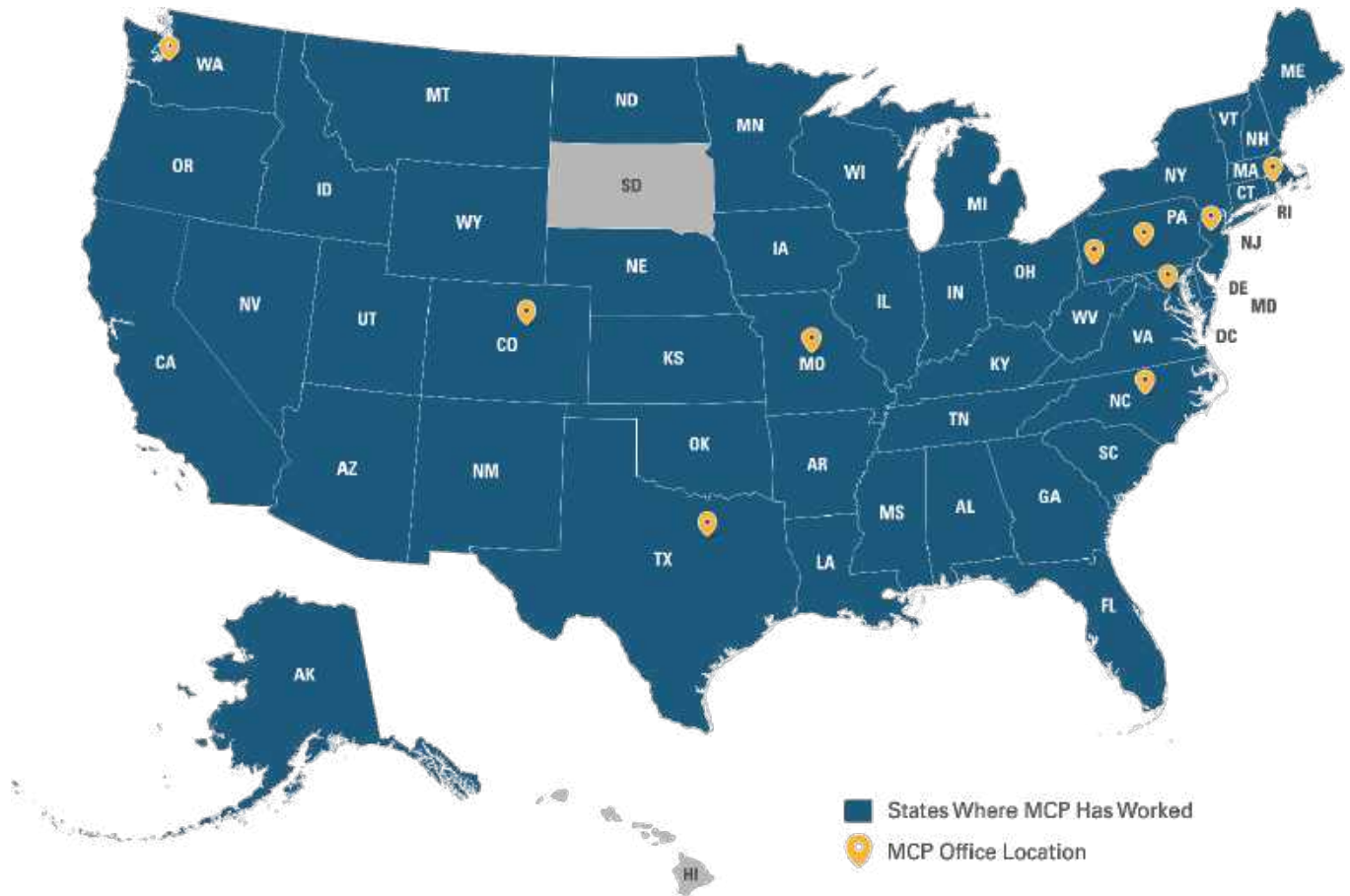

### Corporate Headquarters

690 Gray's Woods Blvd., Port Matilda, PA 16870  
 Phone: 888-862-7911

### Mission Critical Partners Branch Offices

Denver, Colorado    Silver Spring, Maryland    Jefferson City, Missouri

Summit, New Jersey    Raleigh, North Carolina    Cranberry Township, Pennsylvania

Providence, Rhode Island    Southlake, Texas    Seattle, Washington



## We're Committed to Putting our Clients First

Partnering with a firm that brings an independent, objective perspective to every engagement is a top priority of our clients. We stand behind our commitment to always put the fundamental interests of our clients first.

From our inception, vendor-neutrality is a value that underpins every aspect of what we do. Our goal is to determine the most favorable solution for our clients based on their unique requirements, budget, governance structure, operations, and existing technologies. We provide a holistic perspective regarding the entire mission-critical communications ecosystem, free of bias or favoritism to any specific product or service provider. Our recommendations always are based solely on the value and the benefit provided to the client.

For clients, this approach means more control and greater visibility into the systems they ultimately are responsible for operating and maintaining, and—more importantly—a successful project that improves outcomes.

Board of Directors

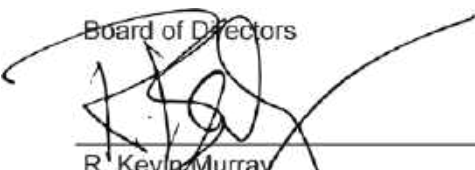
  
R. Kevin Murray

  
Robert Chefitz

  
E. Perot Bissell

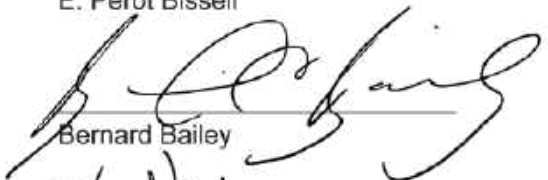
  
Bernard Bailey

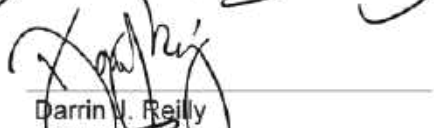
  
Darrin W. Reilly

  
Nola Joyce

Mission Critical Partners (MCP) understands that this project will be a major expense for the Carson City Public Safety Emergency Communications Center (Center). MCP’s rigorous assessment will serve as the foundation for all future system enhancements and will help the Center make better-informed decisions in an uncertain environment. We deliver our recommendations in a multifaceted report that encompasses all key system areas to provide a comprehensive picture of an agency’s needs.

Our methodology ensures that the Center has confidence that the system is not being overengineered and equips you to do more with less by getting the best value from the available budget. MCP has helped clients:

- Lower system maintenance costs by upwards of 20%
- Negotiate savings during the procurement stage that typically ranges from 25% to 40%

### Vendor-Neutrality Experience

MCP has vast experience in implementing complex and multidiscipline technology systems, having worked with large (Tier 1), mid-size, and small computer-aided dispatch/record management system (CAD/RMS) vendors including, but not limited to:

Motorola	Versaterm	New World Systems	VisionAir
Intergraph	InterAct	Zuercher	TriTech
SunGard	Positron	ESO	Harris
Firehouse	VISION	PSSI	AT&T
Aether	Emergitec	Infor	Tiburon

### Monitoring Services

Keeping a mission-critical information technology (IT) environment running smoothly requires constant attention and the availability of highly specialized staff. Network infrastructure needs to be secure, up to date and operating at peak performance, 24x7. Between working with the growing number of network devices, identifying and troubleshooting incidents, and managing routine maintenance requirements, public safety agencies find themselves needing support.

**Mission-Critical NetPulse®** network monitoring services improve network reliability and provide agencies with a greater pulse on their Internet Protocol (IP) network and IT enterprise with technology-agnostic support that spans all aspects of emergency communications.

### A proven, trusted partner means proven, trusted success

No one knows the emergency response communications ecosystem better than MCP. We are the proven, trusted partner behind more than 3,200 mission-critical projects. And the trusted expertise of our field engineers and specialists ensures that mission-critical networks across the country are running smoothly and have reduced risk of unplanned downtime.

### 24x7, independent support, inside and out, and a single point of accountability

**NetPulse Advanced** monitoring services provide proactive and highly responsive around-the-clock remote support services via a network operations center (NOC) that mitigates, escalates, responds, and resolves

network incidents quickly. Our field engineers and specialists develop a deep understanding of the client's network environment and coordinate with every key network component provider and vendor involved with the network on behalf of the client, acting as a clearinghouse that manages incidents and events until issue resolution. MCP offers a variety of service plans that provide varying degrees of support—**Essential, Advanced, Secure, and Custom.**

### A dynamic, integrated view

NetPulse monitoring can provide a holistic, end-to-end view into an agency's entire network and supporting infrastructure, with support available for the following networks and applications:

- CAD
- RMS
- Telephony
- Environmental site networks
- Microwave
- Call-handling equipment (CHE)
- Emergency Services IP networks (ESInets)
- Fiber-optic
- 911 and administrative servers, databases, router, and switches

### Unmatched visibility customized to your needs

MCP provides reporting services via **Mission-Critical NetInform® Discover**, a customizable dashboard and web portal that displays detailed visibility and real-time status of all activities impacting network performance and IT infrastructure. This includes status changes, tickets open, average response times, and incident and event status. MCP also delivers a monthly status report that provides an overview of critical network and IT activities, upcoming maintenance notifications and planned activities, client services, and network engineering support to provide transparent accountability.

Table 1: Sample MCP Monitoring Service Clients

Sample Clients	
Alameda Police Department, CA	Lucas County, OH
Albany/Capital District, NY	Melbourne, FL
Anchorage Police Department, AK	Milwaukee Police Department, WI
Baltimore Police Department, MD	Monterey County, Emergency Communications Center, CA
Brevard County, FL	Monterey County Sheriff's Office, CA
Carson City Sheriff's Office, NV	Montgomery County Sheriff's Office, OH
Forsyth County, GA	New York Metro Transit Authority
Fort Worth, TX	New York State Transit Authority
Harris County Sheriff's Office, TX	Orange County Fire and Rescue, FL
Indianapolis, IN	Orange County Sheriff's Office, FL
La Mesa, CA	

# Statement of Services

## Project Understanding

Mission Critical Partners understands the Carson City Public Safety Emergency Communications Center (Center) has identified the need to obtain a professional services consulting firm to assist with computer-aided dispatch (CAD), records management system (RMS), and jail management system (JMS) assessment and procurement.

On every project MCP leads, our goal is to understand the needs of the client and based on this understanding, develop solutions to meet those needs. Every client and project are unique, with their specific requirements that must be understood to be successful.

MCP will apply our extensive experience and knowledge of public safety software systems in executing the Center's project, ensuring the needs assessment, replacement recommendations, and procurement of the Center's new systems are successful by utilizing our proven project management processes.

MCP has outlined our approach and solution for the Center to support the enhancement of its public safety services. In MCP's experience with similar CAD/RMS/JMS system replacement projects, we typically divide the level of effort into seven distinct phases:

Phase	Description	Tasks
1	Operational and Functional Needs Analysis and Requirements Outline	<ul style="list-style-type: none"> <li>Develop an understanding of the Center's operations and the business needs of project stakeholders</li> <li>Meet with team members/stakeholders to define business processes, functional specifications, and technical requirements</li> <li>Define the Center's interfaces and unique "pain points" to be included in the request for proposal (RFP) and address priorities and future-looking technologies of interest to the stakeholders</li> </ul>
2	Specification Writing/RFP Development	<ul style="list-style-type: none"> <li>Incorporate MCP's best-practice technical specifications, as well as the Center's legal and procurement requirements into the RFP</li> <li>Produce a comprehensive RFP document that incorporates the Center's specific issues that must be addressed by the vendor community</li> <li>Determine specific use-case scenarios and a comprehensive requirements listing</li> </ul>
3	System Procurement Process	<ul style="list-style-type: none"> <li>Support the competitive procurement process in conjunction with the appropriate Carson City procurement department</li> <li>Support the proposal evaluation process with the Center</li> <li>Shortlist vendor finalists and lead the use-case demonstrations with select vendors</li> </ul>

Phase	Description	Tasks
4	Contract Negotiations (30 Hours)	<ul style="list-style-type: none"> <li>Assist the appropriate Center officials, as needed, as they negotiate the vendor contract and provide expertise regarding industry-acceptable contract terms for public safety software systems</li> <li>Support scope of work, milestone billing, and schedule development for inclusion in contract, as appropriate</li> </ul>
<b>Optional Services</b>		
5	System Implementation and Cutover Support	<ul style="list-style-type: none"> <li>Provide insight to the Center regarding the selected vendor's implementation plan</li> <li>Collaboratively manage and oversee the vendor's implementation progress with Center staff</li> <li>Review and critique training plan and delivery</li> <li>Verify and validate delivery of proposed functionality</li> <li>Attend and provide support for system cutover</li> <li>Manage punch list through acceptance period</li> <li>Support testing and system cutover</li> </ul>

In the sections that follow, MCP provides a comprehensive description of our approach during each phase of the project.

## Scope of Work

### Phase 1: Operational and Functional Needs Analysis and Requirements Outline

#### *Task 1.1: Project Initiation*

MCP will conduct a project initiation meeting with the Center's project team and key stakeholder representatives to:

- Establish mutual acquaintance
- Clarify roles
- Review and align regarding desired outcomes and deliverables

Prior to the meeting, MCP will review any available documentation regarding:

- Current Center requirements documents
- Documented interfaces
- Desired system architecture
- Disaster recovery
- RFP template

MCP's project manager (PM) will facilitate the meeting and review the:

- Scope of work
- Project budget
- Tasks, milestones, deliverables, and schedule

### *Task 1.2: User and Stakeholder Requirements Gathering*

MCP anticipates that after the initiation meeting, we will remain on site and hold three days of meetings and interviews to review the current state of the Center's systems and the Center's existing functional requirements and determine content that will be incorporated into the final RFP document. During this effort, MCP will facilitate conversations with stakeholders to consolidate requirements. MCP and the Center's team will evaluate and determine the following:

- The Center's functional priorities
- "Pain points" of the existing system and the Center-specific problem statements
- Future-facing technologies and best practices for inclusion in the RFP

In addition, with MCP's input, the Center will develop use cases for future reference and demonstration purposes.

As determined between the Center and MCP, follow-up discussions, if necessary, will be held with the staff to gain a better understanding of issues identified during the initial on-site visit. Follow-up conversations will collaboratively look at the use cases developed with MCP's assistance to ensure that they are relevant to the RFP document and can serve in the demonstration step, referenced later in this document.

Analysis of the Center's documentation generally will fall into several specific areas of investigation. The team will review the consolidated requirements of the public safety answering point (PSAP) during this phase to ensure that the approach is sufficient to capture data in key focus areas.

MCP will collaborate with the Center to ensure that all necessary systems are properly represented in the Center's RFP document. These can include, but are not limited to:

- Computer-aided dispatch (CAD)
- Mobile data system (MDS)
- Records management system (RMS)
- Jail management system (JMS)
- Automatic vehicle location (AVL)/mapping
- 911 call-handling equipment (CHE)
- Existing and desired interfaces
- Fire station alerting (FSA)

MCP is committed to a holistic approach that helps the Center deploy integrated data-sharing solutions that promote communications interoperability and improve collaboration among the Center agencies, with the end goal being improved emergency response outcomes. As MCP works with the Center on the RFP document, we also will provide insight into the RFP's language regarding vendor scope of work, maintenance, and service level agreement (SLA) management and define use-case descriptions for vendor demonstrations and other general proposal best practices. Additionally, MCP will provide problem statements, considering the information exchanged during this phase, which will be introduced into the RFP document.

**Deliverables:**

- Project initiation meeting
- Requirements and problem-statement outline

## Phase 2: Specification Writing/RFP Development

Once requirements and the problem-statement outline are completed, MCP and the Center core team members will update the RFP document and prepare it for release. The RFP document will be updated to address and define the systems and subsystems to be procured as part of an integrated CAD/RMS/JMS system.

The functional design and specifications that are developed from Phases 1 and 2 include standards-based, statutory, and regulatory requirements. In this regard, MCP draws from many sources including, but not limited to:

Industry Standards
<ul style="list-style-type: none"> <li>• Law Enforcement Information Technology Standards Council (LEITSC)</li> <li>• American National Standards Institute (ANSI)</li> <li>• Telecommunications Industry Association (TIA)</li> <li>• Association of Public-Safety Communications Officials (APCO)</li> <li>• National Emergency Number Association (NENA)</li> <li>• Americans with Disabilities Act (ADA)</li> <li>• National Fire Protection Association (NFPA)</li> <li>• Regional codes and standards</li> <li>• Local application of standards</li> <li>• State regulations</li> </ul>

MCP will provide insight and recommendations regarding components of the RFP document, including:

- The functional specifications desired in the system(s) to be procured
- The procurement process and conditions, to include the Center-required terms and conditions
- The system requirements, content, and format of vendor proposals, so that the proposals received are uniform, cost-competitive and technically acceptable and support a thorough and balanced evaluation process
- Introductory information for the proposer about the procurement process
- Other requirements
  - Project management
  - Configuration, implementation, and acceptance testing
  - Training programs and courses
  - Warranty and service/support capability requirements
  - Lifecycle—total cost of ownership requirements
- Cost proposals
  - Itemized equipment costs
  - Software licensing



- Labor costs and rates
  - Data conversion, if applicable
  - Implementation
  - Project management
- Training
- Software maintenance costs
- Hardware maintenance costs, if applicable
- SLA response and restoral times



**Deliverable:**

- Final Center RFP document

### Phase 3: System Procurement Process

The MCP/Center team will meet to confirm and finalize the Center’s decisions regarding the proposal evaluation process for the future CAD/RMS/JMS system. The intended outcome of this phase is for MCP to provide services to augment the Center’s planning and execution of the CAD/RMS/JMS system purchase. MCP will utilize its extensive experience in:

- Reviewing vendor proposals
- Identifying critical issues, concerns, and discrepancies
- Inquiring about alternative solutions based upon the vendor’s software platform
- Judging the validity of the proposed costs

MCP’s evaluation methodology and toolset have been reviewed by numerous state, city, and municipal procurement offices and legal teams throughout the country. Our ability to modify our existing processes and evaluation tools makes the process of scoring much more efficient for the Center, as well as your procurement and legal representatives.

MCP understands the criticality of maintaining a fair and thorough vendor proposal evaluation process for selection of the solution that best meets the Center’s business needs within the budget parameters. The key initial procurement processes and activities after RFP issuance include:

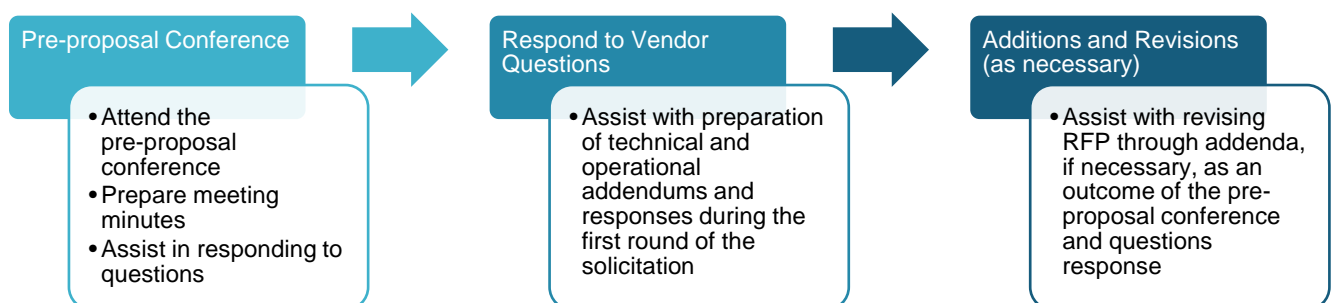

### Task 3.1: Proposal Evaluation

#### Review of Vendor Proposals

MCP will support the Center in its evaluation of proposals from responding vendors and provide technical support throughout the procurement process. In conjunction with the Center personnel, MCP will participate in the review and evaluation of proposals concerning compliance with the RFP's requirements. MCP will:

- Review proposals and provide a summary evaluation to identify noncompliant responses
- Provide technical and administrative consultation during the proposal evaluation and vendor-selection processes utilizing our evaluation matrix to efficiently track the review effort
- Assist with drafting questions to vendors
- Attend a virtual interim evaluation meeting to discuss outstanding issues, as well as a follow-up meeting to review findings and conclusions

### Task 3.2: Vendor Use-Case Evaluation Demonstrations

MCP will assist the Center with conducting vendor use-case evaluations of the top two vendors' solutions, using scenarios crafted specifically for the Center and, if desired, using the Center-provided data.

The MCP team will prepare a use-case evaluation schedule and assist in the development of all use-case evaluation scripts in cooperation with the Center. MCP will facilitate use-case evaluations for up to two vendors to demonstrate their public safety software solutions to the Center stakeholder team. MCP has budgeted one MCP resource to be on site to facilitate the two-day evaluation for each vendor.

After completion of the vendor use-case demonstrations, MCP will facilitate a meeting with the evaluation committee to discuss the demonstrations and socialize the benefits and shortcomings of each vendor's system.

MCP will provide scoring documentation to allow evaluators to judge vendors in a fair and impartial nature. MCP will subsequently lead the evaluation team meetings in which the evaluators decide on the top selected vendor. If necessary, MCP will develop best and final offer letters to the top two vendors for further financial benefit.

#### Evaluation Committee Presentation

MCP will provide a presentation of the recommendation to stakeholders and the Center officials. This is important to ensure that all stakeholders are kept informed regarding the procurement process and the criteria that led to the selection of the vendor.



#### Deliverable:

- Vendor use-case demonstration schedule, scripts, and facilitation
- Evaluation Committee presentation

## Phase 4: Contract Negotiations (30 Hours)

MCP will support the Center's efforts during contract negotiations by specifically focusing on the vendor's statement of work and the payment milestones established as part of the contract. The appropriate Center resources will be responsible for negotiating the contract with the selected vendor.

Once an initial contract is received from the vendor, MCP personnel will:

- Review the contract documents and provide comments regarding the contractual language, scope of work, and line-item pricing that is provided by the vendor
- Redline vendor-supplied software license and maintenance agreements to provide the Center with a foundation as to what should be, and should not be, accepted within the vendor contract agreement
- Participate in strategy meetings with the Center in preparation for vendor negotiation meetings
- Participate in vendor negotiation meetings with the Center as your technical subject-matter expert (SME) and advocate

MCP anticipates 30 hours of contract negotiations effort.

## Optional Implementation Services

### Phase 5: System Implementation and Cutover Support

Should the Center decide to move forward with the optional Phase 5, MCP will provide support to the Center throughout the system implementation process. MCP understands the installation of the new solution(s) must be completed in a manner that results in minimum disruption of activities and limited disruption of dispatching services.

MCP's deployment support focuses on assisting the Center in overcoming the barriers of success typically found in public safety technology projects. MCP will assist the project team and selected vendor(s) in the development of a single, integrated plan that encompasses all activities required to deliver success for system implementation. Our goal is to support the Center during deployment ensuring:

- Compliance with contract requirements and timelines
- Development of test plans and scripts designed to demonstrate functional fulfillment of the technical requirements
- Oversight of all activities associated with the installation of the solution
- Review and approval of all milestone payment certificates
- Review and approval of project change orders, if necessary

MCP will:

- Serve as the Center's advocate and participate in vendor kickoff and planning meetings
- Provide installation oversight
  - Periodically provide personnel on site during the installation process
- Work with the Center and the vendor to develop a punch list of:
  - Issues
  - Roadblocks
  - Software defects
  - Items that fail to conform to the published technical specifications
- Support system cutover, acceptance testing, and final system approval
  - Resolve issues prior to MCP's recommendation to the Center to authorize system acceptance and release final vendor payment

MCP will support the Center in planning, configuration, installation, testing, and go-live activities. Typical responsibilities of the MCP team during this phase can include support such as:

- General project management
- Schedule coordination and integration oversight between the vendor and the Center
- Review of vendor documentation for approval by the Center
- Maintenance of the requirements matrix to document delivery of all contracted items and features
- Identification of discrepancies between the vendor, the Center, and third-party system elements
- Technical representation during functional, integration, and interface acceptance testing
- System transition and post-cutover reliability testing
- Punch list development and open item resolution
- Review of as-built documentation
- Assistance with coordinating vendor and the Center's delivery of training
- Recommendation regarding system acceptance

# Project Team

With more than 200 staff members, MCP’s specialized professionals are integral members of our team:

MCP’s Specialized Professionals	
<ul style="list-style-type: none"> <li>Former executive directors and public safety managers</li> <li>Consolidation and technology specialists</li> <li>Facility and staffing experts</li> </ul>	<ul style="list-style-type: none"> <li>Emergency Number Professionals (ENPs)</li> <li>Technology, forensic, and policy specialists</li> <li>Project Management Professionals (PMPs)</li> </ul>

MCP will support this project with 100% internal staff to protect the Center from the risk of 1099 staff or subcontractors that could delay project initiation, delivery or create contractual issues over responsibilities. The figure below identifies the key team members from our staff that we plan to assign to this important project.

## Organizational Chart

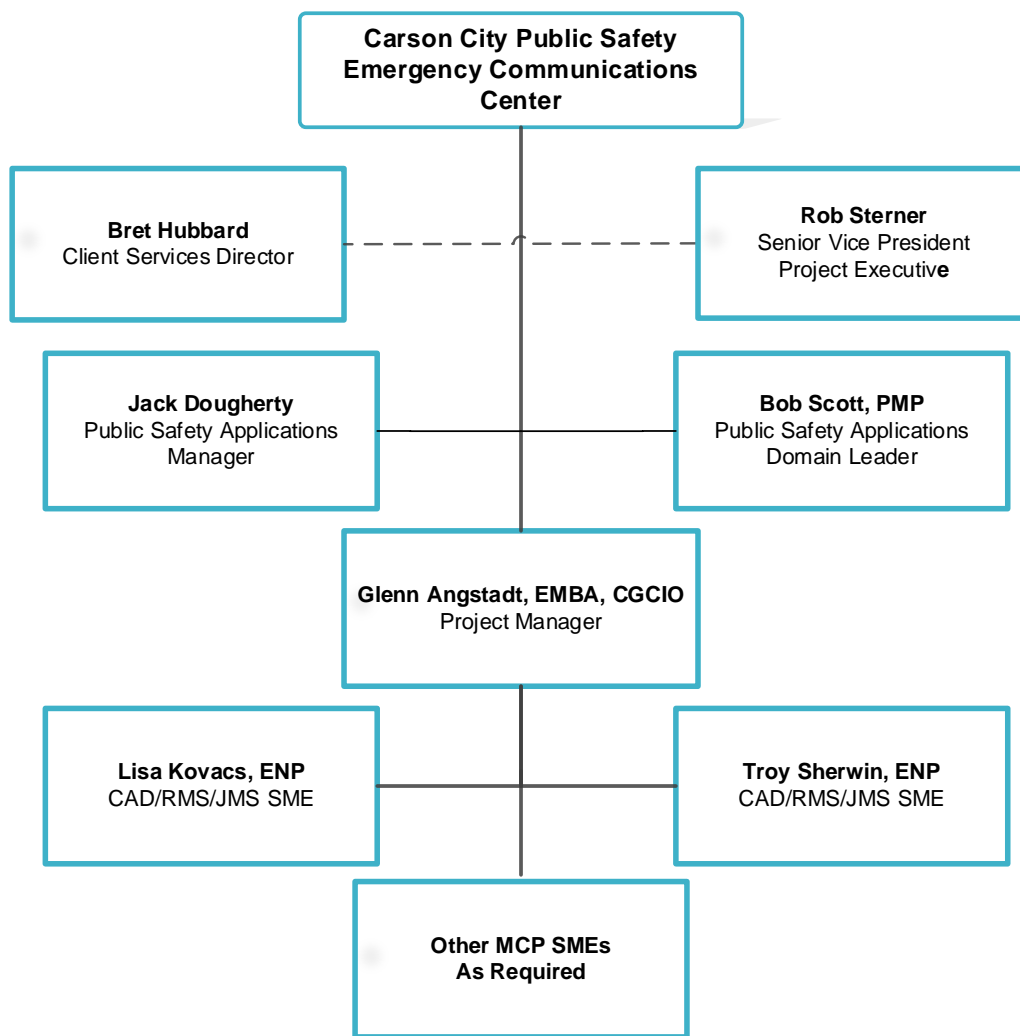

Figure 1: Project Team

Each team member brings a unique skill set and depth of experience in radio system needs assessment. Additional resources and subject-matter experts are also available, as we are a full-service firm focused on all aspects of public safety communications.

## Resumes

Resumes highlighting our qualifications and experience performing CAD/RMS/JMS services are included on the following pages.

## Robert H. Sterner, Jr.

Senior Vice President, Mission Critical Partners

As a senior vice president and client-focused leader responsible for supporting customer satisfaction and business development management, Rob is an experienced communicator who maintains direct contact with public safety clients to resolve project issues. His experience includes executive-level consulting services on multimillion-dollar public safety communications infrastructure projects, contract management and analysis of federal and state legislation and policies that impact public safety. He has researched and developed new public safety and communication technology services for clients in state and county governments and served as a key staff member in the U.S. House of Representatives and Pennsylvania Senate. Areas of specialization include:

- Client manager and executive oversight of projects ensuring expectations are met for client success
- Project manager for PSAP assessments, procurements and implementations of multiple systems

### Representative Experience

#### State/Major Metropolitan Area Experience

- Philadelphia, PA—Radio assessment, maintenance and platform upgrade; 911 center design, implementation and construction support; regional ESInet design and specification development; text-to-911 transition and CAD and records management system (RMS) needs assessment, RFP development and procurement
- Maryland 9-1-1 Board—NG911 planning, implementation, GIS and cybersecurity
- Illinois—NG911 feasibility study
- Illinois—Consolidation projects
  - Cities of O’Fallon and Fairview Heights; Counties of Winnebago, Lake and Kane
- Baltimore, MD—Contract negotiation support, facility feasibility assessment, staffing study, organizational analysis and CAD monitoring
- Northern Virginia Emergency Response System (NVERS)—Fire and EMS assessment
- National Capital Region (NCR)—CAD-to-CAD strategic plan

#### City/County Experience

- Berks County and Bucks County, PA—Southeastern Regional ESInet
- Anne Arundel County, MD—Facility feasibility study
- Frederick County, MD—CAD, RMS, jail management system (JMS) and mobile data system (MDS) assessment, procurement and implementation; NG911 services; communications staffing support and strategic technology planning
- PSAP Assessments—Orange County, Virginia; Adams County, Colorado; Cincinnati, Ohio; City of Richmond, Virginia

#### Additional Experience

- York County, PA—Director, Emergency Center Services Project
  - Directed comprehensive upgrade of the public safety communications infrastructure (new emergency services center facility, P25 LMR, CPE, CAD)
- Pennsylvania Department of Community and Economic Development, Governor’s Center for Local Government Services—Local Government Policy Specialist
- Pennsylvania Department of Labor and Industry—Executive Assistant for Safety and Labor Management Relations and Division Chief, Bureau of PENNSAFE
- U.S. House of Representatives, Education and Workforce Committee—Oversight Staff



### Industry Experience

29 years

### Education

B.A., Government/Public Administration, York College of Pennsylvania

### Associations

National Emergency Number Association (NENA)

Association of Public-Safety Communications Officials (APCO)



## Bret Hubbard

Client Services Director, Western Region, Mission Critical Partners

Bret serves as a client manager who uses his knowledge and skills to foster customer-driven solutions to ensure client needs are met and projects are successful. As the former chief executive officer of a vehicular mobile computer hardware systems and related software company, he has extensive experience serving clients in both the public and private sectors. A proven leader of product and services business development, Bret's core competencies include program and process development, customer relationship management, strategic planning and technical needs assessments. Bret delivers complex high-end solutions to satisfied public safety, military and commercial customers. Bret has excellent communication skills and the ability to deliver solutions while working through adverse conditions.

### Representative Experience

#### City/County/Regional Experience

- Modesto City, CA—PSAP assessment
- Nez Perce County, ID—PSAP consolidation feasibility study
- Salt Lake Valley Emergency Communications Center, UT—Emergency Call Protocol Solution RFP development
- Ravalli County Sheriff's Office, MT—Radio communications tower location study
- Missoula County, MT—Radio system needs assessment
- Pitkin County, CO—PSAP assessment
- El Paso-Teller County 9-1-1 Authority, CO—PSAP regional efficiency study

#### Additional Experience

- Developed technology that became the standard for dash-mounted, airbag safe, sunlight-visible touchscreen computers in vehicles
- Created exclusive supplier contract with vendor for in-vehicle public safety mobile computer systems
- Created and implemented multiple nationwide field service programs resulting in 98% product uptime
- Conducted product-to-market research and deployment
- Championed and built brand recognition across the United States and Canada
- Conducted trending and metrics to develop projections and product directions
- Developed, sold and maintained the first-ever commercial grade sunlight visible car and truck touchscreen computer system and communications software for government, public safety agencies and fleet vehicles
- Identified and remedied clients' pain points
- Achieved long-term relationships with customers and channel partners



### Industry Experience

35 years

### Education

B.S., Marketing,  
Management Information  
Systems, University of  
Arizona

## John (Jack) T. Dougherty

Public Safety Applications Manager, Mission Critical Partners

As MCP's Public Safety Applications Manager, Jack brings 36 years of diverse public safety program and project management experience, including but not limited to CAD, records management system (RMS) and LMR specifications, procurement and implementation, as well as systems integration and facilities construction. Given his experience in state government with the Pennsylvania State Police, working with public safety firms and technology vendors, he is intimately familiar with public safety technology at the city, county, state and federal levels of operations. In addition, Jack has worked with several large metropolitan statistical areas (MSAs) as a program manager.

### Representative Experience

#### Regional/Federal Experience

- National Highway Traffic Safety Administration (NHTSA) National 911 Program—Project manager for CAD data interoperability project
- PennState Health—Project manager for a radio system needs assessment
- Richmond Capital Region—Program director, systems integration, responsible for the implementation of a new regional interoperable LMR system, which included three separate subsystems and integration to a standalone county P25 800 MHz system

#### City/County Experience

- Philadelphia, PA—Senior program manager of 911 consulting multi-year project
  - Program strategy and management
  - LMR upgrades and deployment
  - Design and implementation of a new 911 center
  - Regional ESInet deployment
  - CAD procurement and deployment
  - Disaster recovery and continuity of operations plan
  - Customer premises equipment (CPE) support
  - Pennsylvania Emergency Management Agency (PEMA) grant support
- Atlanta, GA—Project manager of a CAD and RMS implementation and a GIS and CAD administration project

#### Additional Experience

- Pennsylvania State Police, Major-Director of Bureau of Communications and Information Services
  - Oversaw initiation of VHF narrow banding, procurement of P25 dual-band radios and P25 transition planning
  - Led operation/maintenance/security of communications systems and facilities
  - Oversaw the Commonwealth Law Enforcement Assistance Network (CLEAN)
  - Served as a Pennsylvania representative for Nlets – The International Justice and Public Safety Network
- Project manager for the following past projects:
  - Bucks County, PA—700 MHz P25 public safety radio implementation and management of Astro 25 7.14 to 7.16 upgrade
  - Berks County, PA—700 MHz P25 public safety radio network implementation
  - Powhatan County, VA—Public safety radio system assessment and procurement
  - Eastern Shore of Virginia—Radio system interoperability assessment/recommendations
  - Pitt County, NC—700 MHz P25 voice and paging coverage augmentation



### Industry Experience

36 years

#### Education

Northwestern University,  
Center for Public Safety,  
School of Police Staff and  
Command

The Pennsylvania State  
University - Advanced  
Police Executive  
Management

International Association  
of Chiefs of Police (IACP)  
Leadership in Police  
Organizations

Pennsylvania State  
Police Academy-Cadet  
Training

#### Certifications

Change Management  
Specialist

#### Associations

Project Management  
Institute (PMI)

Fraternal Order of Police

Pennsylvania State  
Troopers Association

National Association of  
Professional Accident  
Reconstruction  
Specialists (NAPARS)

## Robert J. Scott, PMP

Public Safety Applications Domain Leader, Mission Critical Partners

Bob served the Pennsylvania State Police (PSP) for 26 years where he had the opportunity to be a project manager for many large public safety technology projects, then leveraged that experience into a successful career as a public safety consultant/project manager. For more than 11 years in the private sector, Bob has led and been a senior technical SME on many public safety projects including public safety software systems procurements and radio system implementations.

### Representative Experience

#### National/State/Regional Experience

- National Highway Traffic Safety Administration (NHTSA) 911 Program Office—Senior technology specialist and CAD SME for CAD interoperability project
- Pennsylvania State Police—Project manager on a records management, CAD, and mobile data systems replacement project; tasks included preparing comprehensive functional requirements, developing an RFP for publication and managing a rigorous vendor evaluation which led to vendor selection
- Pennsylvania Emergency Management Agency (PEMA)—NG911 support and management information system procurement
- Pennsylvania Turnpike Commission—Project manager for public safety radio system RFP
- Northwest Central Dispatch, IL—Project manager for CAD/mobile data/law records management system (RMS)/fire RMS procurement, including RFP development, facilitation of vendor selection, contract negotiations and implementation oversight
- Tri-Com Central Dispatch, IL—Project manager for a CAD/mobile data system technology assessment and strategic technology plan, including business needs assessment, RFP development and contract negotiations

#### City/County Experience

- Philadelphia, PA—
  - CAD/mobile data systems RFI development, to include functional specifications, use-case demonstrations facilitation, vendor selection and contract negotiations
  - Fire RMS and personnel accountability system RFP development
- Atlanta, GA—RMS implementation consultant
- Chicago, IL—CAD/mobile data systems RFP development, vendor evaluation, facilitation of use-case demonstrations and support of contract negotiations
- Frederick County, MD—CAD, mobile data system, law RMS, Fire RMS and jail management system (JMS) systems upgrade, to include assessment, RFP development, vendor negotiation and implementation of public safety software replacement project
- Adams County Communications Center (ADCOM911), CO—PSAP assessment of technology, staffing, facility and operations
- Hamilton County, OH—Communications center efficiency study and funding analysis
- Richmond, VA—PSAP assessment and strategic plan
- Orange County, VA—Emergency communications consolidation feasibility study
- Adams County, PA—Project manager for 800 MHz public safety radio system project, negotiating separate contracts with radio, microwave and tower site vendors and providing implementation oversight of 19 radio tower sites
- Montgomery County, PA—Lead RMS SME for law enforcement RMS procurement project



### Industry Experience

37 years

#### Education

Pennsylvania State  
Police Academy

B.S., Criminal Justice,  
University of Scranton,  
Pennsylvania

#### Certifications

Project Management  
Professional (PMP)

#### Associations

Project Management  
Institute (PMI)

National Emergency  
Number Association  
(NENA)

Association of Public-  
Safety Communications  
Officials (APCO)



## Glenn E. Angstadt, EMBA, CGCIO

Client Manager, Mission Critical Partners

Glenn is a seasoned leader with a broad range of technology, management, operational and communications experience across a diverse spectrum of industries. From venture capital startup to electric utility, human resources, private education, local government and public safety, he has a proven record of success integrating emerging IT trends and quick-to-market services. Some of Glenn's skills include:

- Strategic planning and execution
- Organizational restructuring
- Excellent analytic and logic skills
- Excellent communication skills
- Effective cost cutting
- Emerging technologies
- Process improvement
- Superior presentation skills

### Representative Experience

#### State/Regional Experience

- Pennsylvania Emergency Management Agency (PEMA)
  - NG911 strategic planning
  - Legacy cost and circuit analysis in support of transition to NG911
    - Spatial representation of circuit migration
- County Commissioners Association of Pennsylvania (CCAP)
  - Commonwealth IT security planning
- SEPA Law Enforcement Justice Information System (LEJIS)
  - Steering/governance committee

#### City/County Experience

- Gahanna City, OH
  - Project management of a facility migration, collocating police and fire and implementing a new call handling solution
- Shelby County, TN
  - CAD project management of requirements, procurement and implementation for the cities of Bartlett, Millington and Memphis and the Shelby County Sheriff's Office
- St. Louis, MO
  - New PSAP engineering and design
- Philadelphia, PA
  - New collocated Police/Fire/Office of Emergency Management PSAP (One City, One PSAP)
  - CAD RFP technology/security analysis
  - Fire records management system technology/security analysis
  - Continuity of operations plan/disaster recovery (COOP/DR) assessment and gap analysis
- Palm Beach County, FL
  - 911 program services COOP/DR plan development
- Indiana County, PA
  - Enterprise COOP/DR plan development
- Chester County, PA
  - Full division and departmental direction including systems and services in areas of applications development, business analysts, customer service, infrastructure and enterprise data centers, project management and cybersecurity
  - Infrastructure design and support for CAD system implementation



### Industry Experience

21 years

#### Education

Executive MBA,  
St. Joseph's University,  
PA

B.S., Computer Science  
Albright College, PA

#### Certifications

Certified Government  
Chief Information Officer  
(CGCIO), Public  
Technology Institute  
(PTI)/Rutgers University

#### Associations

PA Emergency  
Management NG911  
Technical Subcommittee

#### Awards and Recognition

*Government Technology*,  
Top 25 Doers, Dreamers  
and Drivers – 2019

## Lisa L. Kovacs, ENP

Communications Consultant, Mission Critical Partners

Lisa is a veteran within the public safety community, serving as a 911 director and public safety software sales support specialist for CAD and mobile systems. Lisa has experience in all facets of public safety software, beginning as a trainer, then implementing systems as a senior project manager. Further on, she became a senior product manager responsible for designing and releasing CAD, mobile and interfaces to records management systems (RMS), jail management systems (JMS), and more than 30 third-party interfaces. Lisa also implemented and was the Training Manager of the National Training Academy, not only training over 150 client sites in preparation for Y2K and new employees but she was also assigned to a special team that assisted in getting the new WebRMS out to the field by helping with the new product's quality assurance/quality control (QA/QC).

### Representative Experience

#### City/County Experience

- Frederick County, MD—Replacement of CAD, mobile and JMS
- Watsonville, CA—RMS implementation
- Jefferson County, MO—CAD assessment
- North Texas Emergency Communications Center, TX—CAD procurement for four agencies
- Denton, TX—Project manager for mobile data automatic vehicle locator (AVL) assessment
- Charlotte, NC—Emergency communications personnel study
- Stanly County, NC—Served as the first 911 Director
  - Established consolidated 911 emergency communications department
  - Coordinated the implementation of E911 and CAD/mapping
  - Led the countywide consolidation of five city police departments, countywide EMS service and 17 fire departments
  - Managed renovations for a new 911 center
- Rock Hill, SC—Served as Telecommunications Division Manager
  - Led renovation to accommodate a new city/county collocated 911 center and consolidated city police and fire communications
  - Managed citywide phone system, including system changes and chargeback to each department for usage

#### Additional Experience

- Served as the program manager responsible for teaching the APCO Telecommunicator Certification program across the country
- Accelerated the development of new RMS web products
- Led state users group meetings, explaining the migration process from VisionCAD to InformCAD and mobile product lines
- Worked with VisionCAD, VisionGIS and VisionLMS
- Researched new trends in the 911 industry
- Performed proposal development and RFP review related to CAD implementation, as well as mapping and mobile systems



### Industry Experience

41 years

#### Certifications

Emergency Number Professional (ENP)

#### Associations

Association of Public-Safety Communications Officials (APCO)

National Emergency Number Association (NENA)

One of the 13 founding members of the NENA Institute Board overseeing the ENP Program and serving for 15 years



## Troy Sherwin, ENP

### Technology Specialist, Mission Critical Partners

Troy is a former law enforcement professional with more than 27 years of experience with the Pennsylvania State Police (PSP), having served in field operations and as lead SME/project manager for several statewide law enforcement technology initiatives. Troy progressed through the ranks of PSP to a niche in public safety software systems, then joined a public safety software company after leaving PSP. His career includes experience in team leadership, business process analysis, project management, technology acquisition and software configuration and deployment. Troy is passionate about leveraging his broad knowledge in public safety technology to better serve clients within emergency communications and field operations.

### Representative Experience

#### *Special Projects/Support Manager Experience*

- Special Projects Manager for Traffic and Criminal Software (TraCS)
  - Served as records management system (RMS) SME for the development team
  - Conducted requirements gathering with clients
  - Worked extensively with Jira, Excel, Word, Adobe and SharePoint
  - Handled entire range of project management duties for all special projects
  - Conducted quality assurance on all special projects
  - Developed, implemented and performed quality assurance for the following functionality for the State of Iowa
    - National Incident-Based Reporting System (NIBRS) standards for the TraCS system project
    - Drug recognition expert data collection form and its subsequent data submission to the National Highway Traffic Safety Administration (NHTSA)
    - Bureau of Investigation and Identity Protection form
  - Applied PennDOT crash data standards for the Commonwealth of Pennsylvania local law enforcement TraCS project
  - Performed extensive configuration updates for the State of New Mexico TraCS project
  - Conducted TraCS proof-of-concept configuration with the State of Texas
  - Performed traffic citation and warnings updates for the State of Vermont
  - Developed and implemented the commercial motor vehicle inspection form and its subsequent submission to Federal Motor Carrier Safety Administration (FMCSA) available for use by all TraCS agencies
- Support Manager for TraCS
  - Managed and collaborated with a team of support specialists, addressing issues for more than 400 local law enforcement agencies in Pennsylvania, as well as 15 state agencies

#### *Additional Experience*

- Pennsylvania State Police Project Lead and Implementation Manager
  - Served as the enlisted project lead for PSP's implementation of a department-wide law RMS, including computer-aided dispatch (CAD), mobile report entry (MRE) and mobile data system (MDS) software
  - Worked with wireless data communications, public safety 800 MHz radio and commercial 3G/LTE, to transmit data to/from PSP mobile computers
  - Spearheaded PSP's implementation of the web-enabled version of TraCS



### Industry Experience

32 years

### Education

Pennsylvania State  
Police Academy

### Certifications

Emergency Number  
Professional (ENP)

Captivate 2, D'vinci  
Interactive

Robohelp X5, D'vinci  
Interactive

TraCS Software  
Development Kit  
Workshop

### Associations

Retired State Police  
Association of  
Pennsylvania



# Experience

## Relevant Project Experience

MCP's proven record of success with CAD/RMS/JMS projects is detailed on the following pages.



## Adams County Communications Center, Colorado

### Records Management System and Jail Management System Implementation Support



**Challenge:** In September 2017, Adams County Communications Center (ADCOM) identified the need to assess the status and outlook of its web-based records management system (RMS) implementation. ADCOM retained Mission Critical Partners to provide professional consulting services with the RMS implementation and to provide support for the Adams County Sheriff's Office jail management system (JMS) implementation.

**Solution:** To support this project, MCP's subject-matter experts provided technical, operation and contractual support to deliver a comprehensive assessment that identified alternatives for ADCOM and prioritized recommendations on the best path forward. MCP completed the following tasks:

- Conducted a needs assessment, data gathering and initial RMS interviews
- Discussed potential alternatives with ADCOM and the RMS team
- Supported independent verification and validation of the RMS software
- Assisted in defining core functionality for the RMS based upon user need and industry best practices

**Key Result:** In October 2017, MCP delivered a report of its initial findings and provided an updated report in December 2017. MCP continued to assist ADCOM in providing consultation services directly to the ADCOM Director and the RMS testing team to further the progress of the implementation and to help formulate a strategy to ensure the best interest of ADCOM and its agencies were served by this critical deployment.

**Project Length:** 1 Year

**Project Dates:** September 2017 to November 2018

**Population:** 504,108 (2021)

**Nearest MSA:** Denver-Aurora-Lakewood, CO

**Contact:**

Joel Estes  
Director  
Adams County  
Communications Center  
303.289.2235  
[jestes@adcom911.org](mailto:jestes@adcom911.org)

## El Paso-Teller County 911 Authority, Colorado

### Centralized CAD Implementation Support

**Challenge:** The El Paso-Teller County 911 Authority (Authority) sought to obtain professional consulting services to overcome any barriers to success typically found in a public safety technology implementation project and ultimately oversee the implementation of the system.

**Solution:** Mission Critical Partners was retained to work with the Authority and the PSAPs served by the Authority participating in this project to confirm deliverables being proposed by the CAD vendor. MCP also assisted with overarching project management to meet the needs of the Authority and the member agencies it serves, including:

- CAD System Implementation and Cutover Support
  - Development of integrated plans that tracked and managed activities required to deliver successful implementation
  - Support to the Authority in planning, configuration, installation, testing, and go-live activities
- Additional Implementation Activities
  - General project management
  - Coordination and integration oversight between the CAD vendor and the Authority
  - Review of CAD vendor documentation for approval by the Authority
  - Identification of demarcation points for discrepancies between the contractor, the Authority and third-party system elements
  - Technical representation during functional, integration and interface acceptance testing
  - System transition and post-cutover reliability testing
  - Punch list development and open item resolution
  - Review of as-built documentation
  - Recommendation regarding system acceptance

**Key Result:** MCP supported the Authority in confirming requirements and provided project management support for deploying the new centralized CAD system. MCP aided the Authority during deployment, ensured compliance to contract requirements, developed test plans and scripts designed to demonstrate functional fulfillment of the requirements, and oversaw activities associated with solution implementation.



**Project Length:** 2 Years

**Project Dates:** December 2018 to June 2020

**Population:** 993,751 (2021)

**Nearest MSA:** Colorado Springs, CO

**Contact:**

Carl Simpson  
 Chief Executive Officer,  
 El Paso-Teller County 911  
 Authority  
 719.785.1900  
[csimpson@elpasoteller911.org](mailto:csimpson@elpasoteller911.org)

## City of Denton, Texas

### CAD and RMS Procurement and Implementation Support

**Challenge:** The City of Denton, Texas, (City) is located about 40 miles northwest of the Dallas-Fort Worth metroplex. The city encompasses about 88 square miles and has a population of about 130,000. The population of the city is expected to grow by at least 80 percent by 2030. The city's public safety answering point (PSAP) provides 911 call-taking and dispatching services to the Denton Police Department and the Denton Fire Department. The PSAP handles more than 120,000 emergency calls for service annually.

The City sought to replace its aging computer-aided dispatch (CAD) system, mobile data system, and law enforcement and fire department records management systems (RMS) with a scalable integrated solution that would accommodate the city's growth. The CAD and RMS needed to interface with numerous other software applications.

**Solution:** The City hired Mission Critical Partners to support the CAD and RMS procurement and implementation effort. MCP subject-matter experts performed specific tasks during the project that included:

- Development of a comprehensive set of technical requirements for each of the applications to assure needed functionality
- Scope of work development document to ensure that vendor could successfully deliver the proposed solution
- Pre-proposal vendor conference support
- Technical expertise and assistance to the City in crafting questions for the vendors
- Support to the City staff throughout the proposal evaluation and scoring process
- Vendor demonstrations and site visit support
- Vendor selection and contract negotiation
- Oversight of system implementation, testing, cutover and vendor-provided training

**Key Result:** The City released an RFP that included the scope of work/technical requirements document in December 2017. MCP supported the City's procurement effort with vendor on-site demonstrations occurring in September 2018. MCP assisted the City throughout the implementation process.



**Project Length:** 2.75 Years

**Project Dates:** March 2017 to December 2019

**Population:** 136,195 (2021)

**Nearest MSA:** Dallas-Fort Worth-Arlington, TX

**Contract Vehicle:** H-GAC

**Contact:**

Melissa Kraft  
 Director of Technology  
 Services  
 940.349.7823  
[melissa.kraft@cityofdenton.com](mailto:melissa.kraft@cityofdenton.com)

## City of Atlanta, Georgia

### Centralized CAD Implementation Support



**Challenge:** The City of Atlanta (City) sought to obtain professional consulting services to mitigate, identify and ultimately resolve any discrepancies between the City's requirements and the proposed solution by the vendor. The City realized that implementing a CAD project of this size, complexity and potential ambiguity would be overly time-consuming and precarious even with a dedicated Public Safety IT team; therefore, the City sought to retain an experienced public safety firm to oversee the implementation of the system.

**Solution:** Mission Critical Partners was retained to work with the City and the Hartsfield-Jackson Atlanta International Airport to confirm that deliverables being proposed by the CAD vendor meet the requirements and needs of the City both contractually and implied. MCP is also assisting with overarching project management to meet the City's needs including:

- CAD System Implementation and Cut-over Support
  - Development of integrated plans that track and manage all activities required to deliver success for implementation
  - Support to the City in planning, configuring, installation, testing and go-live activities
- Additional Implementation Activities
  - General project management
  - Schedule coordination and integration oversight between CAD vendor and the City
  - Review of CAD vendor documentation for approval by the City
  - Identification of demarcation points for discrepancies between contractor, the City and third-party system elements
  - Technical representation during functional, integration and interface acceptance testing
  - System transition and post-cut-over reliability testing
  - Punch list development and open item resolution
  - Review of as-built documentation
  - Recommendation regarding system acceptance

**Key Result:** MCP is currently supporting the City in confirming requirements and providing project management support for deploying the new centralized CAD system. MCP is aiding the City during deployment by ensuring compliance to contract requirements, development of test plans and scripts designed to demonstrate functional fulfillment of the requirements, and oversight of activities associated with the solution being implemented.

**Project Length:** 2 Years

**Project Dates:** June 2019 to Present

**Population:** 488,800 (2021)

**Nearest MSA:** Atlanta-Sandy Springs-Alpharetta, GA

**Contact:**

Arlanda Ross  
 Atlanta Information  
 Management Program Director  
 404.886.1428  
[adross@atlantaga.gov](mailto:adross@atlantaga.gov)

## St. Mary's County, Maryland

### CAD Procurement and Implementation Support

**Challenge:** Located in southern Maryland, St. Mary's County's serves a population of 112,667 people and often sees an upswing of 30,000 people per day traveling to the County for recreational purposes. The Department of Emergency Services is the only PSAP in the County and is responsible for all 911 call taking and dispatching for one law enforcement, 14 fire and EMS agencies, and animal control dispatch.

The County identified the need to obtain professional consulting services to support the procurement and implementation of a fully integrated operational turnkey system to enhance the delivery of public safety services.

**Solution:** MCP was retained by the County to provide specification and request for proposal (RFP) development to support the procurement of CAD/mobile data system (MDS)/law records management system (LRMS) solutions. MCP's support includes:

- Operational and functional needs analysis and requirements
- RFP development and specification writing
- System procurement support and contract negotiations
- System implementation and cutover support

**Key Result:** MCP is currently developing a draft RFP to assist in procuring a new system to enhance the County's current capabilities for its citizens and first responders. MCP has conducted on-site stakeholder interviews to obtain the necessary information and operational understanding to develop an RFP that will best suit the unique needs of the County's stakeholders. Additionally, MCP has worked with the procurement office to ensure the RFP will meet all needs of the County's procurement process.



**Project Length:** 3 Years

**Project Dates:** August 2018 to Present

**Population:** 113,510 (2021)

**Nearest MSA:** California-Lexington Park, MD

**Contract Vehicle:** H-GAC

**Contact:**

Stephen Walker

Director

240.808.0167

[Stephen.Walker@stmarysmd.com](mailto:Stephen.Walker@stmarysmd.com)

## Southeastern Pennsylvania Regional Task Force

### CAD-to-CAD Implementation



SOUTHEASTERN PENNSYLVANIA  
*Regional Task Force*

**Challenge:** The Southeastern Pennsylvania Regional Task Force (SEPARTF) is tasked with ensuring the safety of millions of residents that live in the greater Philadelphia metropolitan area. Covering more than 2,700 square miles and 244 municipalities, SEPARTF serves the Urban Area Security Initiative (UASI) region that includes Bucks, Montgomery, Delaware and Chester counties, as well as the City and County of Philadelphia. SEPARTF desired expertise and consultative assistance to support the development of requirements to deploy a CAD-to-CAD solution to meet the current and future needs of the region and its citizens.

**Solution:** Mission Critical Partners was retained to support Delaware County and SEPARTF 911 leadership to develop a CAD-to-CAD solution. MCP proposed services included:

- Developing a white paper to orient and educate project stakeholders and ensure a common level of understanding
- Conducting a needs assessment
- Gathering data focusing on both technology and operational process flows, policies, capabilities
- Determining the desired feature set in a CAD-to-CAD solution
- Developing a Request for Information (RFI)
- Developing use cases and subsequent questions regarding incident workflow and configurations that provide regional leaders with a comprehensive evaluation of available features and functions of current CAD-to-CAD and data exchange platforms
- Developing a Request for Proposal (RFP)
- Developing requirements based on nationally established and accepted public safety standards and best practices regarding data sharing, IP traffic routing, cybersecurity and network reliability
- Supporting contract negotiation and procurement
- Coordinating all activity regarding the review and negotiation of proposed equipment and service contracts from prospective vendors for the CAD-to-CAD solution
- Supporting the development of the vendor scope of work for hardware, software and services
- Monitoring the overall project schedule and providing support to streamline the procurement process
- Providing project management/vendor oversight
- Providing recommendation on final acceptance

**Key Result:** In late 2018, MCP supported the development of the RFI that was subsequently issued. MCP supported the coordination of the response evaluation of any subsequent vendor presentations that may occur as a result of the RFI. Additionally, content from the RFI was used to develop a comprehensive RFP. MCP provided support to SEPARTF with the evaluation of vendor proposals and the implementation anticipated to occur in late 2020.

**Project Length:** 3 Years

**Project Dates:** June 2018 to Present

**Population:** 3.2 million (2021)

**Nearest MSA:** Philadelphia-Camden-Wilmington, PA-NJ-DE-MD

**Contract Vehicle:** General Services Administration (GSA)

**Contact:**

Timothy Boyce  
Director  
Delaware County Emergency Services  
610.565.8700  
[boycet@co.delaware.pa.us](mailto:boycet@co.delaware.pa.us)

## City of Chicago, Illinois

### CAD Procurement Support and Contract Negotiations

**Challenge:** With a population of almost three million residents, the City of Chicago (City) is the third largest city in the United States and one of the most visited cities in the country. The City desired expertise and consultative assistance to support the procurement of a new CAD system and to evaluate potential solutions for a needed replacement with state-of-the-art technology to provide increased efficiency to meet the City's strategic direction and the needs of its citizens and visitors.

**Solution:** Mission Critical Partners was retained as a sub-consultant to Clarity Partners, LLC to facilitate the CAD vendor evaluation and selection process for the City's Office of Emergency Management and Communications (OEMC) and to provide support for CAD vendor contract negotiations. MCP's tasks included the following:

- Prepared for and conducted initial planning session with evaluation team
- Determined roles, responsibilities and deliverables
- Performed critical review of proposals prior to evaluation committee review
- Conducted internal knowledge transfer session on methods for evaluating responses to maximize consistency in evaluations by the evaluation team
- Supported evaluation committee review of RFP responses based on established criteria and facilitated discussions around key points of disparity and clarified understanding of the responses
- Drafted, reviewed and finalized a list of clarifying questions to each vendor
- Facilitated the evaluation team sessions to discuss the short-listed firms and reach a consensus recommendation to the chief procurement officer
- Drafted vendor evaluation summary and evaluation committee recommendation
- Facilitated use case demonstration sessions including three vendors, two days for each presentation
- Maintained communications with vendors, prepared contract negotiation checklist, reviewed scope of work (SOW) and prepared agenda for SOW negotiation
- Facilitated SOW negotiation sessions and reviewed software license and implementation services agreements

**Key Result:** With MCP's support, the City received best and final offers from the two vendor finalists and entered the final stages of selecting its new CAD solution with all the necessary information to ensure a successful procurement and implementation.



**Project Length:** 1.5 Years

**Project Dates:** April 2018 to January 2020

**Population:** 2.71 Million (2021)

**Nearest MSA:** Chicago-Naperville-Elgin, IL-IN-WI

**Contact:**

Martin Doyle, Managing Deputy Director, Office of Emergency Management and Communications (retired), 312.743.1322

Chief Jonathan Lewin, Former Chief, Bureau of Technical Services, Chicago Police Dept. (retired, now with FirstNet), 773.220.9999, [jonathan.lewin@outlook.com](mailto:jonathan.lewin@outlook.com)



## Frederick County, Maryland

### Computer-Aided Dispatch and Public Safety Software Solutions Upgrade



**Challenge:** Frederick County (County) identified the need for assessment and procurement support in the acquisition of a new public safety software solution. The County is responsible for providing public safety support to its citizens and was seeking to update the following systems:

- Computer-aided dispatch (CAD)
- Mobile data system (MDS)
- Law enforcement records management system (RMS)
- Jail management system (JMS)

Located in the rapidly growing and sixth largest metropolitan statistical area in the United States (Washington-Arlington-Alexandria, DC-VA-MD-WV MSA), the County sought a consulting firm to assist in obtaining a solution that would fit the increasing needs of the region's first responders.

**Solution:** Mission Critical Partners was retained by the County to provide support for the following tasks:

- Operational and Functional Needs Analysis and Requirements Outline
  - User and stakeholder requirements gathering
  - Analysis of findings
  - Recommendations development
  - Findings presentation
- Specification Writing and Request for Proposals Development
  - Contract negotiations
- System Procurement Support
  - Vendor proposal review
  - Vendor use case evaluations
  - Public Safety Steering Committee presentation

**Key Result:** In December 2019, MCP and the County kicked off the project. MCP is currently providing operational and functional needs analysis to the County to ensure a CAD, MDS, RMS, and JMS solution that meets the current and future needs of the County and its first responders.

**Project Length:** 2.75 Years

**Project Dates:** December 2019 to Present

**Population:** 271,717 (2020)

**Nearest MSA:** Washington-Arlington-Alexandria, DC-VA-MD-WV

**Contact:**

Jack Markey  
 Director  
 Division of Emergency  
 Management  
 301.600.6790  
[emergencymanagement@frederickcountyMD.gov](mailto:emergencymanagement@frederickcountyMD.gov)



## Frederick County, Maryland

### JMS and Public Safety Software Solutions Upgrade

**Background:** Frederick County (County) 911 Center serves as the primary PSAP for all incoming 911 calls for police, fire, EMS and animal control. The County is responsible for providing public safety support to its citizens and identified the need for an updated, integrated solution that best meets the operational needs of the end users.

**Challenge:** The County identified the need for assessment and procurement support for a new CAD, MDS, and Law RMS and the acquisition of a new JMS being used for jail records tracking and inmate management for the Frederick County Adult Detention.

**Solution:** Mission Critical Partners was retained to provide support for the following tasks:

- Operational and Functional Needs Analysis and Requirements Outline (Completed)
  - User and stakeholder requirements gathering
  - Analysis of findings
  - Recommendations development
  - Findings presentation
- Specification Writing and Request for Proposals Development (In Progress)
  - RFP development
  - Contract negotiations
- System Procurement Support
  - Vendor proposal reviews
  - Vendors use case evaluations
  - Public Safety Steering Committee presentation

**Key Result:** MCP provided the County with an operational and functional needs analysis to ensure that the JMS, CAD, MDS, and RMS, solution meets the current and future needs of the County and its first responders.

Using the data and information collected during the assessment, MCP delivered a final RFP in August 2020 to support the County in procuring the new systems. MCP is currently supporting the County in the procurement and evaluation process.

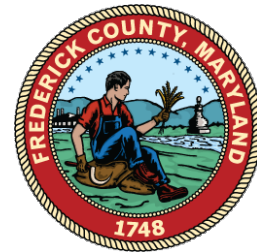

**Project Length:** 2.75 Years

**Project Dates:** December 2019 to Present

**Solutions Provided:**

Needs Assessment

RFP Development

Procurement

Evaluation Support

**Population:** 271,717 (2020)

**Nearest MSA:** Washington-Arlington-Alexandria, DC-VA-MD-WV

**Contact:**

**JMS**

Captain Timothy Selin,  
Frederick County Adult  
Detention Center,  
301.600.3065

[tselin@frederickcountyMD.gov](mailto:tselin@frederickcountyMD.gov)

**CAD/RMS/MDS**

Jack Markey, Director, Division  
of Emergency Management  
301.600.6790

[emergencymanagement@frederickcountyMD.gov](mailto:emergencymanagement@frederickcountyMD.gov)

## Indiana County, Pennsylvania

### Regional CAD System Implementation

**Challenge:** Five Pennsylvania counties that are members of the Region 13 Task Force—Indiana, Armstrong, Fayette, Greene and Somerset—currently are sharing 911 call-handling and land mobile radio resources via their interconnection to the WestCORE Emergency Services Internet Protocol (IP) Network (ESInet) and the Inter County Regional Radio System (ICORRS), a Project 25, Phase II digital trunked radio system operating in the 800 MHz band. The counties sought to extend this regional approach to their CAD capabilities.

**Solution:** Mission Critical Partners was hired to help the counties assess their options regarding CAD-to-CAD networking, with an eye toward the implementation of regional sharing of CAD information and resources. The task was made more challenging by the fact that while they all are located in the southwest corner of the state, not all of the adjoining counties utilize the same vendor solution.

MCP performed the following key tasks:

- Evaluated the CAD systems currently used by the counties
- Conducted a comprehensive assessment of current and future needs
- Provided technical guidance
- Provided oversight of CAD-to-CAD system implementation

**Key Result:** The five counties opted to deploy New World CAD systems manufactured by Tyler Technologies, and to implement a CAD-to-CAD interface that enables the counties to interconnect with other counties that are not using a Tyler CAD solution. The result is greatly enhanced call-transferring and data-sharing capabilities, as well as system resiliency and redundancy.

MCP is currently supporting the implementation process.



**Project Length:** 5 Years

**Project Dates:** July 2016 to Present

**Population:** 83,246 (2020)

**Nearest MSA:** Indiana, PA

**Contact:**

Thomas Stutzman  
Emergency Management  
Coordinator

724.349.9300

[tstutzman@indianacounty.org](mailto:tstutzman@indianacounty.org)

## City of Memphis, Tennessee

### Computer-Aided Dispatch Implementation



**Challenge:** As part of its ongoing efforts to strengthen countywide public safety services, the Shelby County Emergency Communications District (SCECD) sought to fund two CAD systems, including one for the Memphis Police Department (PD).

In 2012, MCP was selected by the SCECD to conduct user level and command staff stakeholder meetings to determine system needs. MCP's support of the CAD procurement process included the following services:

- Developed the technical requirements for the CAD RFP
- Supported the evaluation process and creation of scoring tools
- Managed the interview process for finalists, including on-site visits for reference purposes
- Supported the contract negotiation process
- Supported the scope of work development and acceptance plan documentation for the selected CAD provider
- Developed and oversaw the implementation plan to upgrade the selected system

The Memphis PD sought to retain MCP to provide guidance and management of the implementation phase of the project.

**Solution/Key Result:** To support the City of Memphis in the deployment of its new CAD system, MCP provided the following implementation support services:

- Worked with the vendor to negotiate and support implementation plan development
- Validated contractual obligations during implementation
- Supported the client during acceptance testing and validated testing was documented
- Tracked and worked with selected vendor for remediation of failed acceptance testing
- Oversaw remediation documentation from vendor on failed acceptance testing

The system was upgraded/cutover on March 28, 2017.

**Project Length:** 2 Years

**Project Dates:** July 2016 to June 2018

**Population:** 633,104 (2020)

**Nearest MSA:** Memphis, TN-MS-AR

**Contact:**

Raymond Chiozza

Executive Director

901.380.3900

[rchiozza@shelbycounty911.org](mailto:rchiozza@shelbycounty911.org)

## Northwest Central Dispatch System, Illinois

### CAD/MDS/RMS Project Management



**Challenge:** Northwest Central Dispatch System (NWCDS) is a joint PSAP responsible for answering all incoming 911 calls and processing all emergency and non-emergency police, fire and EMS events for its 13 members and contracted agencies. NWCDS serves 11 suburban Illinois communities located northwest of Chicago. As of 2017, the combined population of these 11 communities had reached approximately 500,000 citizens.

NWCDS was in need of a new CAD system and mobile data system (MDS), as well as law records and fire records management systems (RMSs). The key aspect of this project was to identify NWCDS' operational and system requirements, publish them in a comprehensive request for proposals (RFP) and assist in selecting products best suited to enable NWCDS and its partner agencies to fulfill their mission. The selected system must have the capability to scale appropriately to meet specific performance criteria now and in the future, while also accommodating workload increases based on the potential for new communities and/or agencies to join NWCDS. The system would also need to be sized to ensure sufficient data storage capacities that met initial data requirements but also could be easily increased to adjust to changes in call volume, operational needs and expanded system functionality.

**Solution:** Mission Critical Partners was hired to develop functional and system requirements for the new, more robust system required by NWCDS. A team of MCP public safety professionals worked with NWCDS to develop an RFP to procure the necessary systems, conducted rigorous vendor evaluations and assisted NWCDS in selecting a vendor.

MCP was actively engaged in negotiating a contract with the selected vendor and has been retained by NWCDS to oversee the implementation of the new system (after contract signing), a process which is estimated to take approximately 15 months.

**Key Result:** MCP's extensive experience with RFP development and our vendor-neutral approach to the procurement process have allowed NWCDS to develop and publish an RFP with a level of expertise not readily available within the agency and provided NWCDS with invaluable marketplace insights into vendor offerings and pricing. The RFP process resulted in seven vendor responses, and ongoing contract negotiations with the selected vendor have already resulted in significant cost savings for NWCDS. MCP is currently overseeing the implementation of the CAD/MDS/RMS solution.

**Project Length:** 5 Years

**Project Dates:** April 2017 to Present

**Population:** 500,000 (2017)

**Nearest MSA:** Chicago-Naperville-Elgin, IL-IN-WI

**Contact:**

John Ferraro  
Executive Director  
847.590.3408  
[jferraro@nwcads.org](mailto:jferraro@nwcads.org)

## City of Philadelphia, Pennsylvania

### FRMS, CAD and MDS Solution



**Challenge:** The City of Philadelphia (City) operates the busiest PSAP in Pennsylvania; it receives more than three million calls annually, representing one-third of all 911 calls placed in the Commonwealth. The City identified the need for professional consulting services to support the procurement process for a new multidiscipline, citywide CAD, mobile data solution (MDS), and fire records management system (FRMS) solution to replace its 30-year-old system that faced continually increasing support costs.

The City had been operating two disparate CAD platforms for law enforcement and fire services for many years and identified the need to obtain a system that could provide an integrated solution with FRMS, MDS and CAD software.

**Solution:** Mission Critical Partners was retained by the City to provide support in soliciting statements of interest, capabilities and rough order of magnitude (ROM) cost estimates for a potential solution. MCP's support includes:

- Request for Information (RFI)
  - Developed an initial RFI
  - Revised the RFI with input from stakeholders from the Police Department (PD), Fire Department (FD) and the Office of Innovation and Technology (OIT)
- Proposal Evaluation
  - Facilitated a rigorous evaluation alongside the FD and PD in three distinct evaluation phases
  - Conducted critical review of proposals
  - Developed functional specifications response/written responses to use case scenarios
  - Assisted in vendor use case demonstrations
- Vendor Use Case Demonstrations
  - Supported use case demonstrations in which vendors presented their software using Philadelphia-specific scripts

**Key Result:** MCP supported the development of an initial RFI published in October 2017. As a part of the evaluation process, MCP reviewed nine vendor responses. MCP provided a report highlighting an overview of the proposals and written feedback from PD and FD evaluators, along with the pros and cons of each vendor/solution.

With MCP's evaluation support, the City's PD and FD evaluators selected two vendors who had scored highest in the evaluation process to participate in the use case demonstrations.

MCP is currently supporting the City in the development of a request for proposal for CAD and mobile data software licenses and implementation, maintenance and support services.

**Project Length:** 4 Years

**Project Dates:** March 2017 to Present

**Population:** 1.58 million (2021)

**Nearest MSA:** Philadelphia-Camden-Wilmington, PA-NJ-DE-MD

**Contact:**

Nadine Dodge  
Interim Deputy Chief  
Information Officer  
City of Philadelphia Office of  
Innovation & Technology  
215.834.8420  
[nadine.dodge@phila.gov](mailto:nadine.dodge@phila.gov)

## Shelby County Emergency Communications District, Memphis, Tennessee

### Computer-Aided Dispatch Implementation



**Challenge:** As part of its ongoing efforts to strengthen countywide public safety services, the Shelby County Emergency Communications District (SCECD) sought to fund two CAD systems, including one for the Shelby County Sheriff and Fire Departments.

Mission Critical Partners previously supported the SCECD in coordinating the CAD procurement process, including:

- Facilitated user level and command staff stakeholder meetings to determine system needs
- Developed the technical requirements for the CAD request for proposal (RFP)
- Supported the evaluation process and creation of scoring tools
- Managed the interview process for finalists, including on-site visits for reference purposes
- Supported the contract negotiation process
- Supported the scope of work development and acceptance plan documentation for the selected CAD provider
- Developed and oversaw the implementation plan to deploy the selected systems

The SCECD sought to retain MCP to provide oversight support for the implementation phase of the project.

**Solution/Key Result:** To support the Shelby County Sheriff and Fire Department in the deployment of its new CAD system, MCP provided the following implementation support services:

- Worked with vendor to negotiate and support implementation plan development
- Validated contractual obligations during implementation
- Developed acceptance test plans (ATPs)
- Validated that ATPs were adhered to during implementation
- Worked with selected vendor for remediation for failed acceptance testing
- Oversaw remediation documentation from vendor on failed acceptance testing

The CAD system was cutover live on September 19, 2017.

**Project Length:** 2 Years

**Project Dates:** July 2016 to June 2018

**Population:** 937,166 (2021)

**Nearest MSA:** Memphis, TN-MS-AR

**Contact:**

Raymond Chiozza  
Executive Director  
901.380.3900  
[rchiozza@shelbycounty911.org](mailto:rchiozza@shelbycounty911.org)

“When two of our major PSAPs in the county needed technical proposals for new CAD systems, we turned to MCP.”

- Raymond Chiozza,  
Executive Director Shelby County  
Emergency Communications  
District

## Wake County, North Carolina

### CAD and Mobile Data Systems

**Challenge:** The Raleigh–Wake County Emergency Communications Center (RWECC) is the primary PSAP for the City of Raleigh and much of Wake County. The legacy system was a Motorola Premier CAD System that was initially installed in 2003 and vendor end of life support was scheduled for August 31, 2018. The system was configured to be multi-PSAP, multi-agency, and multi-jurisdictional, serving a total of 44 agencies, including:

- Ten law enforcement agencies
- 19 fire agencies
- Four emergency medical service (EMS) units functioning as one system
- One crime scene and investigations unit
- Seven public utilities agencies

Additionally, there were four other state, city and county public safety support agencies that used the CAD system. The system supported approximately 250 full CAD workstations with terminals in three remote PSAPs. There were also many agencies that used the Premier Mobile Data client, with approximately 1,700 users.

**Solution:** Mission Critical Partners was retained to assist with the development of a request for proposal (RFP) for a CAD system that would meet the current and future needs of the RWECC. MCP provided support in evaluating vendor responses once the RFP was released and then assisted with installation oversight of the selected CAD solution.

**Key Result:** MCP held stakeholder interviews to determine systems needs and assess the current system. Based upon the assessment and interviews, MCP produced the technical specifications report which documents the methods, analysis, findings, and system specification recommendations. The specifications listed in this document were then used in the technical specification section of the RFP. The report described the methodologies used to develop the specifications, preliminary project and implementation schedules and acceptance testing strategies related to RWECC's CAD solution objectives.

MCP assisted the County and RWECC with system testing and system go-live. MCP also supported the County with system acceptance as well as network configuration documentation and systems administration policy/procedure documentation.



**Project Length:** 4 Years

**Project Dates:** January 2016 to January 2020

**Population:** 1.11 million (2021)

**Nearest MSA:** Raleigh-Cary, NC

**Contact:**

John Higgins  
 Director of Information Services  
 Wake County  
 919.664.5575  
[john.higgins@wakegov.com](mailto:john.higgins@wakegov.com)

# Pricing



Professional services outlined in the scope of work for Phases 1 through 4 will be provided for a **not-to-exceed fee of \$165,191.00**. The fee is inclusive of labor and expenses. Phase 5: System Implementation and Cutover Support, is proposed as an optional service, with pricing to be determined later if this service is desired.

Table 2: Pricing by Phase

Phase	Labor Fee	Travel	Total
Phase 1: Operational and Functional Needs Analysis and Requirements Outline	\$38,485	\$5,000	\$43,485
Phase 2: Specification Writing/RFP Development	\$55,156	\$0	\$55,156
Phase 3: System Procurement Process	\$56,929	\$4,300	\$61,229
Phase 4: Contract Negotiations (30 Hours)	\$5,321	\$0	\$5,321
<b>Grand Total</b>	<b>\$155,891</b>	<b>\$9,300</b>	<b>\$165,191</b>

Table 3: Payment Milestones

Milestone	Fee
Milestone 1: Project Initiation Meeting and Stakeholder Interviews Complete	\$21,742.50
Milestone 2: Requirements Outline with Problem Statements Complete	\$21,742.50
Milestone 3: Develop Draft RFP	\$27,578.00
Milestone 4: Final RFP Complete	\$27,578.00
Milestone 5: Pre-Proposal Conference, Vendor Questions and Addenda Complete	\$20,410.00
Milestone 6: Proposal Evaluations Complete, Short List for Demos Developed	\$20,410.00
Milestone 7: Vendor Use-case Demonstrations and Evaluation Committee Presentation Complete	\$20,409.00
Milestone 8: Contract Negotiations (30 Hours)	\$5,321.00
<b>TOTAL</b>	<b>\$165,191.00</b>

Mission Critical Partners proposes to deliver services on a per-hour basis based on GSA Schedule 70, Contract #GS-35F-0410X, with meals and lodging defined at Federal per diem rates.

At the close of each month, MCP shall submit a properly executed invoice showing services rendered for that month. Each statement shall include labor and expenses for authorized activities based upon the approved scope of work. Reimbursable expenses on this project will be invoiced using Federal per diem rates for lodging,

mileage, and meals. All other expenses including airfare, rental cars, rental fuel, local transportation, tolls, parking, and taxes on lodging will be invoiced at the cost incurred.

Any additional services contracted in subsequent years will be performed at MCP's then-current fee schedule. Prior to initiating any such additional work, MCP would require a formal letter of authorization from the Carson City Public Safety Emergency Communications Center.

Based on the current MCP understanding of what is to be accomplished, the pricing identified represents an estimate of the work anticipated for the project to be successful. MCP's priority is for this project to be successful for the Carson City Public Safety Emergency Communications Center.

# Appendix A: The Public Safety Ecosystem and MCP Service Offerings

Since 911's inception in 1968, public safety officials have continued to leverage technology advancements to make emergency response even more efficient and effective. The counterbalance is these advancements occurred in distinct silos that developed within the emergency communications ecosystem (enhanced 911 service, digital land mobile radio networks, and computer-aided dispatch systems).

Today, we stand on the precipice of another technology transformation like the advent of 911 service. As public safety moves through this transformation over the next several years and beyond, it is critical that the agencies begin thinking of the ecosystem as a holistic network, i.e., a network of networks.

The new public safety ecosystem will interconnect on many levels to enable the smooth flow of critical and relevant data to provide emergency responders with the best information to perform their duties.

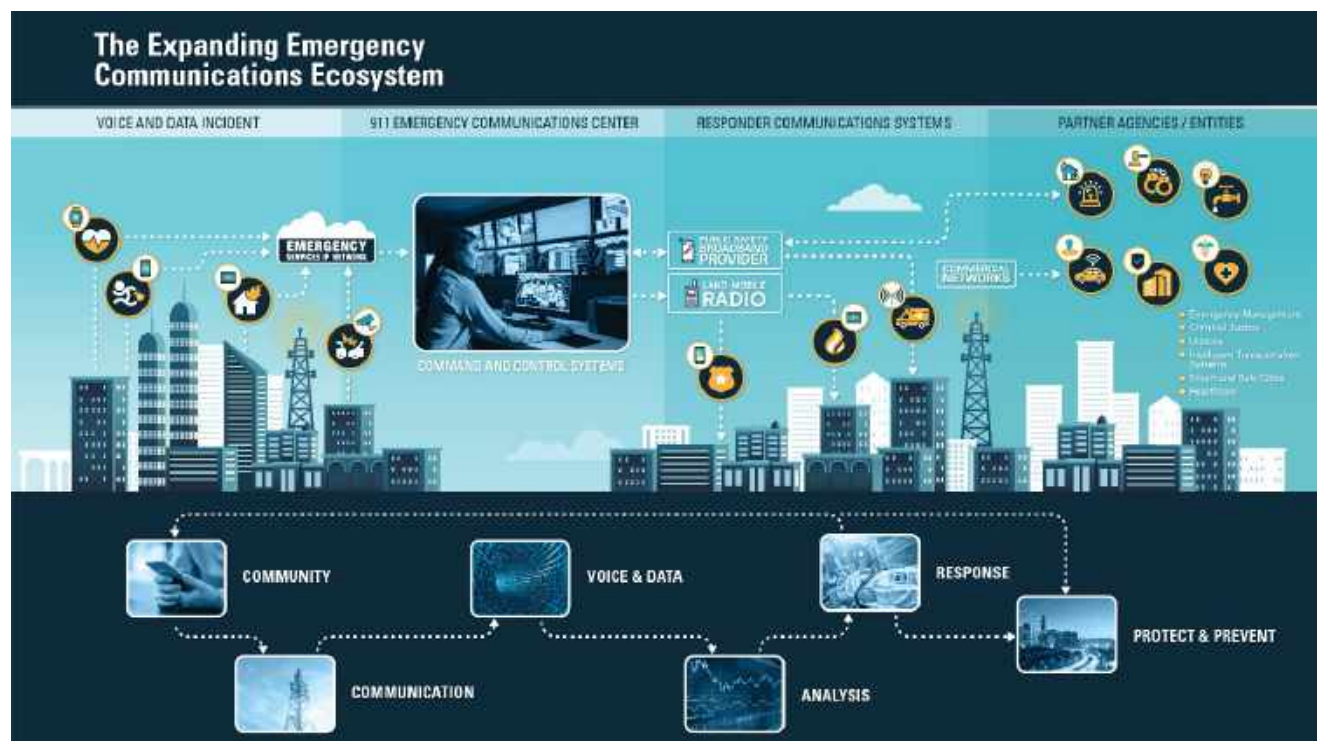

MCP can provide the public safety, criminal justice, data integration, network and information technology services required to help agencies start thinking of the ecosystem as a single entity, taking into consideration how each piece will interconnect and interact with the others. With MCP's support, agencies will transition from siloed communication environments to realizing significant improvements in emergency-response outcomes.



MCP specializes in transforming mission-critical networks and operations into integrated ecosystems that improve outcomes in the public safety, courts and corrections, healthcare, transportation, and utility markets.



## Consulting and Advisory Services

### Network and 911 Services

**Specialties:** Next Generation 911, Emergency Services IP Networks, text-to-911, call-handling equipment, cloud applications

- Assessments, procurement and implementation
- Program and project management
- Geographic information systems planning, design, implementation and administrative services

### Operations and Facilities Services

**Specialties:** computer-aided dispatch, records management, mobile data systems, mission-critical facilities

- Facility planning and construction
- Consolidation and shared services
- Strategic and operations consulting
- Training and professional development
- Technology procurement and implementation
- Continuity of operations planning
- Recruiting and hiring support

### Wireless Communications Services

**Specialties:** land mobile radio, broadband, microwave, alert and warning systems, fire station alerting systems, FirstNet, bi-directional amplifiers

- Master planning
- Project management
- Technical and operational needs assessments and design
- System procurement and negotiations
- Implementation and construction management
- Testing and validation

### Justice, Management, and Technology Services

**Specialties:** integrated justice, courts, case management, corrections, repositories, and biometric identification systems

- Assessments and data collection
- Strategic planning and governance support
- Business process transformation and systems architecture design
- Financial planning
- Information systems acquisition and procurement
- Implementation and change management support



## Managed Services

### SecureHalo Cybersecurity Solutions and Network and IT Services

- Mission-Critical NetInform® Secure cybersecurity assessments
- NetInform discovery of network assets
- Vendor management
- Mission-Critical NetPulse® network and application monitoring
- NetPulse-Secure cybersecurity monitoring
- IT support, outsourcing and staff augmentation
- Cybersecurity training

### Data Integration and Analytics

- DataLink™ interface mapping
- Business process mapping and design
- DataSphere™ enterprise integration
- Planning, governance and architecture of data-sharing initiatives
- DataScope™ advanced analytics, powered by machine learning and artificial intelligence
- Alternatives to traditional data migration
- Database management
- Software and application development



## STAFF REPORT

**Report To:** Board of Supervisors                      **Meeting Date:** March 2, 2023

**Staff Contact:** Carol Akers, Purchasing & Contracts Administrator and Darren Schulz, Public Works Director

**Agenda Title:** For Possible Action: Discussion and possible action regarding a determination that ACCO Engineered Systems, Inc. (“ACCO”) is the lowest responsive and responsible bidder pursuant to Nevada Revised Statutes (“NRS”) Chapter 338, and whether to award Contract No. 23300231 for the Juvenile Courts Multi-Zone HVAC Unit Replacement Project (“Project”) to ACCO for a total amount not to exceed \$317,753.70. (Carol Akers, cakers@carson.org and Randall Rice, rrice@carson.org)

Staff Summary: The Project consists of replacing one multi-zone HVAC unit located on the southern section of the roof of the Juvenile Courts building. The not to exceed amount of \$317,753.70 comprises the base bid amount of \$288,867, plus a 10% contingency of \$28,886.70. The engineer’s base bid estimate was \$290,000. The Project was approved as part of the Fiscal Year (“FY”) 2023 Capital Improvement Plan (“CIP”).

**Agenda Action:** Formal Action / Motion                      **Time Requested:** Consent

---

### **Proposed Motion**

I move to approve the contract as presented and authorize the Public Works Director to approve expenditure of the 10 percent contingency, if necessary.

### **Board's Strategic Goal**

Sustainable Infrastructure

### **Previous Action**

May 19, 2022 (Item 17A): The Board of Supervisors approved the final budget for FY 2023, including the CIP.

### **Background/Issues & Analysis**

The Project includes removing and replacing one multi-zone HVAC unit located on the southern section of the roof of the Juvenile Courts Building located at 1545 East 5th Street. The Project will include all engineering, design, permitting, piping, labor and materials to remove the existing multi-zone HVAC unit and install a new multi-zone HVAC unit.

Bids for the Project were initially solicited in the fall of 2022. The City received only one bid in response, for \$420,992.

A second notice to contractors regarding the opportunity to bid on this Project was published in the Reno Gazette Journal and posted on NGEM on January 25, 2023. Three bids were opened at approximately 11:30 a.m. on February 14, 2023 via online Cisco Webex bid opening. Present during the bid opening were: Meile Young, ACCO; Parth Gandhi, Monument Construction; Michael Friend and Ron Reed, Carson City Public Works; and Alexis Philippi, EO Office Specialist and Carol Akers, Carson City Purchasing and Contracts Administrator.

The following bids were received:

Bidder	Base Bid
1. ACCO	\$288,867
2. Monument Construction	\$360,004
3. Gardner Engineering	\$443,628

Staff recommends award to ACCO as the lowest responsive and responsible bidder pursuant to NRS Chapter 338.

**Applicable Statute, Code, Policy, Rule or Regulation**

NRS Chapter 338

**Financial Information**

**Is there a fiscal impact? Yes**

**If yes, account name/number:** Project # P303423202  
Extraordinary Maintenance Fund - Capital Improvements Account / 3403034-507010

**Is it currently budgeted? Yes**

**Explanation of Fiscal Impact:** Project # P303423202, Account 3403034-507010 will be reduced by a not to exceed amount of \$317,753.70. The total project budget (Project Number P303423202) for design and construction is \$340,000. The project funding available is \$337,984.

**Alternatives**

Do not approve the contract and provide alternative direction to staff.

**Attachments:**

[23300231 Bid Tabulation\\_ROA.pdf](#)

[23300231 DRAFT Contract.pdf](#)

**Board Action Taken:**

Motion: _____	1) _____	Aye/Nay
	2) _____	_____
		_____
		_____
		_____

\_\_\_\_\_  
(Vote Recorded By)

**Notice to Contractors Bid# 23300231 Juvenile Courts HVAC Replacement Project**

**Date and Time of Opening: 2/14/2023 @ 11:30am**

				ACCO Engineered Systems Inc.		Monument Construction		Gardner Engineering, Inc	
Line #	Description	QTY	UOM	Unit	Extended	Unit	Extended	Unit	Extended
1	Schedule A: Base Bid Items	1	EA						
1.1	Design, Permitting, Removal and Replacemer	1	LS	\$288,867.00	\$288,867.00	\$360,004.00	\$360,004.00	\$443,628.00	\$443,628.00
				<b>Total Price</b>	<b>\$288,867.00</b>	<b>\$360,004.00</b>		<b>\$443,628.00</b>	

**Carson City is recommending award to ACCO Engineered Systems, Inc. and is tentatively scheduled for approval and award at the March 2, 2023 Board of Supervisors meeting.**

# CONSTRUCTION INDEPENDENT CONTRACTOR AGREEMENT

Contract No: 23300231

## Title: Juvenile Courts HVAC Replacement Project

THIS CONTRACT is made and entered into this 2nd day of March 2023, by and between Carson City, a consolidated municipality, a political subdivision of the State of Nevada, hereinafter referred to as "CITY", and ACCO Engineered Systems, Inc., hereinafter referred to as "CONTRACTOR".

### WITNESSETH:

**WHEREAS**, the Purchasing and Contracts Manager for **CITY** is authorized pursuant to Nevada Revised Statutes (hereinafter referred to as "NRS") 338 and Carson City Purchasing Resolution #1990-R71, to approve and accept this Contract as set forth in and by the following provisions; and

**WHEREAS**, this Contract involves a "public work," which pursuant to NRS 338.010(18) means any project for the new construction, repair or reconstruction of an applicable project financed in whole or in part from public money; and

**WHEREAS**, **CONTRACTOR'S** compensation under this agreement (does \_\_\_) (does not X) utilize in whole or in part money derived from one or more federal grant funding source(s); and

**WHEREAS**, it is deemed necessary that the services of **CONTRACTOR** for **CONTRACT No. 23300231**, titled **Juvenile Courts HVAC Replacement** (hereinafter referred to as "Contract") are both necessary and in the best interest of **CITY**; and

**NOW, THEREFORE**, in consideration of the aforesaid premises, and the following terms, conditions and other valuable consideration, the parties mutually agree as follows:

#### 1. REQUIRED APPROVAL:

This Contract shall not become effective until and unless approved by the Carson City Board of Supervisors and all required documents are received and signed by all parties.

#### 2. SCOPE OF WORK (Incorporated Contract Documents):

2.1 The parties agree that the Scope of Work will be specifically described and hereinafter referred to as the "WORK." This Contract incorporates the following attachments, and a **CONTRACTOR'S** attachment shall not contradict or supersede any **CITY** specifications and/or terms or conditions without written evidence of mutual assent to such change appearing in this Contract:

2.1.1 **CONTRACTOR** agrees that the Contract Documents for **Bid No. 23300231** including, but not limited to, the Notice to Contractors, Project Coordination, Instructions to Bidders, Contract Award Information, General Conditions, Special Conditions, Technical Specification, Prevailing Wages, Contract Drawings, and Addenda, if any, are intended to be complete and complementary and are intended to describe a complete WORK. These documents are incorporated herein by reference and made a part of this Contract. All of these documents can be viewed through the Carson City Website <https://carson.org/bids>.

2.1.2 **CONTRACTOR** additionally agrees **CONTRACTOR'S** Bid Bond, Bid Proposal, Proposal Summary, Executed Contract, Performance Bond, Labor and Material Bond, Certificate of Eligibility, Insurance Certificates, Permits, Notice of Award, Notice to Proceed and Executed Change Orders, hereinafter all referred to as Exhibit A, are incorporated herein and made a part of this Contract.

For P&C Use Only

CCBL expires	_____
NVCL expires	_____
GL expires	_____
AL expires	_____
WC expires	_____



# CONSTRUCTION INDEPENDENT CONTRACTOR AGREEMENT

Contract No: 23300231

Title: Juvenile Courts HVAC Replacement Project

## 3. CONTRACT TERM AND LIQUIDATED DAMAGES:

3.1 **CONTRACTOR** agrees to complete the WORK on or before the date specified in the Notice to Proceed or any executed Change Orders to the entire satisfaction of **CITY** before final payment is made, unless sooner termination by either party as specified in **Section 6** (CONTRACT TERMINATION) and the General Conditions, Section GC 3.18.

3.2 Pursuant to the provisions under Time for Completion and Liquidated Damages in the Contract Documents of said Specifications, **CONTRACTOR** will complete the WORK within the Contract time. Since **CITY** and **CONTRACTOR** agree it is difficult to ascertain the actual amount of damages incurred due to delay of the Project, it is agreed that **CITY** will be paid the liquidated damages as specified in the Contract Special Conditions for each and every calendar day of delay in the completion of the WORK, in addition to any direct charges incurred by **CITY** as a result of delay of the Project, including engineering fees and additional damages due to late construction. **CITY** also reserves the right to deduct any amounts due **CITY** from any monies earned by **CONTRACTOR** under this Contract.

3.3 That in the performance of this Contract, **CONTRACTOR** and any subcontractors, as employers, shall pay 1 ½ times an employee's regular wage rate whenever an employee who received compensation for employment at a rate less than 1 ½ time the minimum wage who works more than forty (40) hours in any scheduled work week, more than eight (8) hours in a day, unless by mutual agreement the employee works a scheduled ten (10) hours per day for four (4) calendar days within a work week. Employers should refer to NRS 608.018, NRS 338.020 and A.O. 2013-04 for further details on overtime requirements.

## 4. NOTICE:

4.1 Except the bid and award process where notices may be limited to postings by **CITY** on its Bid Opportunities website ([www.carson.org](http://www.carson.org)), all notices or other communications required or permitted to be given under this Contract shall be in writing and shall be deemed to have been duly given if delivered personally in hand, by e-mail, by regular mail, by telephonic facsimile with simultaneous regular mail, or by certified mail, return receipt requested, postage prepaid on the date posted, and addressed to the other party at the address specified below.

4.2 Notice to **CONTRACTOR** shall be addressed to:

Ben Lillig, Project Manager  
ACCO Engineered Systems, Inc.  
2010 Kleppe Lane  
Sparks, NV 89431  
775-277-1802  
[Blillig@accoes.com](mailto:Blillig@accoes.com)

4.3 Notice to **CITY** shall be addressed to:

Carson City Purchasing and Contracts Department  
Carol Akers, Purchasing and Contracts Administrator  
201 North Carson Street, Suite 2  
Carson City, NV 89701  
775-283-7362 / FAX 775-887-2286  
[CAkers@carson.org](mailto:CAkers@carson.org)

## 5. COMPENSATION:

# CONSTRUCTION INDEPENDENT CONTRACTOR AGREEMENT

Contract No: 23300231

## Title: Juvenile Courts HVAC Replacement Project

5.1 The parties agree that **CONTRACTOR** will provide the WORK specified in the Contract for the Contract Amount of Two Hundred Eighty Eight Thousand Eight Hundred Sixty Seven Dollars and 00/100 (\$288,867.00).

5.2 **CITY** will pay **CONTRACTOR** progress payments and the final payment computed from the actual quantities of WORK performed and accepted and the materials furnished at the Unit and Lump Sum prices shown on **CONTRACTOR'S** Bid Proposal and any executed Change Orders.

5.3 Contract Amount represents full and adequate compensation for the complete WORK, and includes the furnishing of all materials, all labor, equipment, tools, transportation, services, appliances, and all expenses, direct or indirect connected with the proper execution of the WORK.

5.4 **CITY** does not agree to reimburse **CONTRACTOR** for expenses unless otherwise specified.

### 6. CONTRACT TERMINATION:

#### 6.1 Termination Without Cause:

6.1.1 Any discretionary or vested right of renewal notwithstanding, this Contract may be terminated upon written notice by mutual consent of both parties or unilaterally by either party without cause.

6.1.2 **CITY** reserves the right to terminate this Contract for convenience whenever it considers termination, in its sole and unfettered discretion, to be in the public interest. In the event that the Contract is terminated in this manner, payment will be made for WORK actually completed. If termination occurs under this provision, in no event shall **CONTRACTOR** be entitled to anticipated profits on items of WORK not performed as of the effective date of the termination or compensation for any other item, including but not limited to, unabsorbed overhead. **CONTRACTOR** shall require that all subcontracts which it enters related to this Contract likewise contain a termination for convenience clause which precludes the ability of any subcontractor to make claims against **CONTRACTOR** for damages due to breach of contract, lost profit on items of WORK not performed, or unabsorbed overhead, in the event of a convenience termination.

#### 6.2 Termination for Nonappropriation:

6.2.1 All payments and WORK provided under this Contract are contingent upon the availability of the necessary public funding, which may include various internal and external sources. In the event that Carson City does not acquire and appropriate the funding necessary to perform in accordance with the terms of the Contract, the Contract shall automatically terminate upon **CITY'S** notice to **CONTRACTOR** of such nonappropriation, and no claim or cause of action may be based upon any such nonappropriation.

#### 6.3 Cause Termination for Default or Breach:

6.3.1 A default or breach may be declared with or without termination.

6.3.2 This Contract may be terminated by either party upon written notice of default or breach to the other party as follows:

6.3.2.1 If **CONTRACTOR** fails to provide or satisfactorily perform any of the conditions, WORK, deliverables, goods, or any services called for by this Contract within the time requirements specified in this Contract or within any granted extension of those time requirements; or

6.3.2.2 If any state, county, city or federal license, authorization, waiver, permit, qualification or certification required by statute, ordinance, law, or regulation to be held by

# CONSTRUCTION INDEPENDENT CONTRACTOR AGREEMENT

Contract No: 23300231

## Title: Juvenile Courts HVAC Replacement Project

**CONTRACTOR** to provide the goods or WORK or any services required by this Contract is for any reason denied, revoked, debarred, excluded, terminated, suspended, lapsed, or not renewed; or

6.3.2.3 If **CONTRACTOR** becomes insolvent, subject to receivership, or becomes voluntarily or involuntarily subject to the jurisdiction of the bankruptcy court; or

6.3.2.4 If **CITY** materially breaches any material duty under this Contract and any such breach impairs **CONTRACTOR'S** ability to perform; or

6.3.2.5 If it is found by **CITY** that any quid pro quo or gratuities in the form of money, services, entertainment, gifts, or otherwise were offered or given by **CONTRACTOR**, or any agent or representative of **CONTRACTOR**, to any officer or employee of **CITY** with a view toward securing a contract or securing favorable treatment with respect to awarding, extending, amending, or making any determination with respect to the performing of such contract; or

6.3.2.6 If it is found by **CITY** that **CONTRACTOR** has failed to disclose any material conflict of interest relative to the performance of this Contract.

6.3.2.7 **CITY** may terminate this Contract if **CONTRACTOR**:

6.3.2.7.1 Fails to maintain bonding, Nevada State Contractors' Board License, State Industrial Insurance requirements or insurance policies for limits as defined in this Contract; or

6.3.2.7.2 Persistently or materially refuses or fails to supply properly skilled workers or proper materials; or

6.3.2.7.3 Fails to make payment to subcontractors for materials or labor in accordance with the respective agreements between **CONTRACTOR** and the subcontractors; or

6.3.2.7.4 Disregards laws, ordinances, or rules, regulations or order of a public authority having jurisdiction; or

6.3.2.7.5 Otherwise makes a material breach of a provision of this Contract; or

6.3.2.7.6 **CONTRACTOR** fails to maintain safe working conditions.

6.3.3 When any of the Subsection 6.3.2.7.1 through 6.3.2.7.6, inclusive, cause reasons exist, and without prejudice to any other rights or remedies of **CITY**, **CITY** may terminate this Contract at any time after giving **CONTRACTOR** and **CONTRACTOR'S** Surety seven (7) calendar days written notice of default or breach and intent to terminate and **CONTRACTOR'S** subsequent failure to timely correct as provided below, and subject to any prior rights of the Surety, **CITY** may:

6.3.3.1 Take possession of the site and of all materials, equipment, tools and construction equipment and machinery thereon owned by **CONTRACTOR**;

6.3.3.2 Accept assignment of subcontractors pursuant to this Contract (Contingent Assignment of Subcontracts to Carson City if this Contract is terminated); and

6.3.3.3 Finish the WORK by whatever reasonable method **CITY** may deem expedient.

# CONSTRUCTION INDEPENDENT CONTRACTOR AGREEMENT

Contract No: 23300231

## Title: Juvenile Courts HVAC Replacement Project

6.3.4 If **CITY** terminates this Contract for any of the cause reasons stated in **Section 6.3**:

6.3.4.1 **CONTRACTOR** shall not be entitled to receive further payment until the WORK is finished.

6.3.4.2 If the unpaid balance of the Contract Amount exceeds the cost of finishing the WORK including expenses made necessary thereby, such excess shall be paid to **CONTRACTOR**. If the costs of finishing the WORK exceed the unpaid balance, **CONTRACTOR** shall pay the difference to **CITY**. The amount to be paid to **CONTRACTOR** or **CITY**, as the case may be, shall survive termination of this Contract.

6.3.4.3 In the event of such cause termination, all monies due **CONTRACTOR** or retained under the terms of this Contract shall be held by **CITY**, however, such holdings will not release **CONTRACTOR** or its Sureties from liability for failure to fulfill this Contract. Any excess cost over and above the Contract Amount incurred by **CITY** arising from the termination of the operations of this Contract and the completion of the WORK by **CITY** as provided above shall be paid for by any available funds held by **CITY**. **CONTRACTOR** will be so credited with any surplus remaining after all just claims for such completion have been paid.

6.4 If at any time before completion of the WORK under this Contract, the WORK shall be stopped by an injunction of a court of competent jurisdiction or by order of any competent government authority, **CITY** may give immediate notice to **CONTRACTOR** to discontinue the WORK and terminate this Contract. **CONTRACTOR** shall discontinue the WORK in such manner, sequence, and at such times as **CITY** may direct. **CONTRACTOR** shall have no claim for damages for such discontinuance or termination, nor any claim for anticipated profits on the WORK thus dispensed with, nor for any claim for penalty, nor for any other claim such as unabsorbed overhead, except for the WORK actually performed up to the time of discontinuance, including any extra WORK ordered by **CITY** to be done.

6.5 Time to Correct (Declared Default or Breach):

6.5.1 Termination upon a declared default or breach may be exercised only after providing 7 (seven) calendar days written notice of default or breach, and the subsequent failure of the defaulting or breaching party, within five (5) calendar days of providing that default or breach notice, to provide evidence satisfactory to the aggrieved party demonstrating that the declared default or breach has been corrected. Time to correct shall run concurrently with any notice of default or breach and such time to correct is not subject to any stay with respect to the nonexistence of any Notice of Termination. Untimely correction shall not void the right to termination otherwise properly noticed unless waiver of the noticed default or breach is expressly provided in writing by the aggrieved party. There shall be no time to correct with respect to any notice of termination without cause, termination for nonappropriation or termination due to court injunction or order of a competent government authority.

6.6 Winding Up Affairs Upon Termination:

6.6.1 In the event of termination of this Contract for any reason, the parties agree that the provisions of this **Subsection 6.6** survive termination:

6.6.1.1 The parties shall account for and properly present to each other all claims for fees and expenses and pay those which are undisputed and otherwise not subject to set off under this Contract. Neither party may withhold performance of winding up provisions solely based on nonpayment of fees or expenses accrued up to the time of termination; and

6.6.1.2 **CONTRACTOR** shall satisfactorily complete WORK in progress at the agreed rate (or a pro rata basis if necessary) if so requested by **CITY**; and

# CONSTRUCTION INDEPENDENT CONTRACTOR AGREEMENT

Contract No: 23300231

## Title: Juvenile Courts HVAC Replacement Project

6.6.1.3 **CONTRACTOR** shall execute any documents and take any actions necessary to effectuate an assignment of this Contract if so requested by **CITY**; and

6.6.1.4 **CONTRACTOR** shall preserve, protect, and promptly deliver into **CITY** possession all proprietary information in accordance with **Section 21**.

### 6.7 Notice of Termination:

6.7.1 Unless otherwise specified in this Contract, termination shall not be effective until seven (7) calendar days after a party has provided written notice of default or breach, or notice of without cause termination. Notice of Termination may be given at the time of notice of default or breach, or notice of without cause termination. Notice of Termination may be provided separately at any time after the running of the 7-day notice period, and such termination shall be effective on the date the Notice of Termination is provided to the party unless a specific effective date is otherwise set forth therein. Any delay in providing a Notice of Termination after the 7-day notice period has run without a timely correction by the defaulting or breaching party shall not constitute any waiver of the right to terminate under the existing notice(s).

## 7. DAVIS-BACON & RELATED ACTS 29 CFR PARTS 1,3,5,6,&7 AND NRS 338.070(5):

*In the event federal grant funds are used for payment of all or part of this Contract*

7.1 **CONTRACTOR** shall comply with Davis-Bacon Act and NRS 338.070(5). **CONTRACTOR** and each covered contractor or subcontractor must provide a weekly statement of wages paid to each of its employees engaged in covered WORK. The statement shall be executed by **CONTRACTOR** or subcontractor or by an authorized officer or employee of **CONTRACTOR** or subcontractor who supervised the payment of wages and shall be on the "Statement of Compliance" form. **CONTRACTOR** shall submit a Statement of Compliance that is prescribed by the Nevada Labor Commissioner or contains identical wording. Per NRS 338.070(6) the records maintained pursuant to subsection 5 must be open at all reasonable hours to the inspection of the public body (the **CITY'S** representative) awarding the contract. The **CONTRACTOR** engaged on the public work or subcontractor engaged on the public work shall ensure that a copy of each record for each calendar month is received by the public body awarding the contract (the **City**) **no later than 15 days after the end of the month**.

7.2 In the event federal funds are used for payment of all or part of this Contract, **CONTRACTOR** shall submit a Statement of Compliance form WH347 or a form with identical wording and a Statement of Compliance prescribed by the Nevada Labor Commissioner **within 7 days after the regular pay date for the pay period**. The original Statements shall be delivered to Carson City Public Works, 3505 Butti Way, Carson City, Nevada 89703, attention Davis-Bacon/Federal Funding Compliance.

### 7.3 CERTIFIED PAYROLLS FOR DAVIS-BACON AND PREVAILING WAGE PROJECTS:

7.3.1 The higher of the Federal or local prevailing wage rates for **CITY**, as established by the Nevada Labor Commission and the Davis-Bacon Act, shall be paid for all classifications of labor on this project WORK. Should a classification be missing from the Davis-Bacon rates the **CONTRACTOR** shall complete a request of authorization for additional classification or rate form SF1444 in its entirety and submit it to the **CITY** for approval and submission to the U.S. Department of Labor. Also, in accordance with NRS 338, the hourly and daily wage rates for the State and Davis-Bacon must be posted at the work site by **CONTRACTOR**. **CONTRACTOR** shall ensure that a copy of **CONTRACTOR'S** and subcontractor's certified payrolls for each calendar week are received by **CITY**.

7.3.2 Per NRS 338.070(5) a **CONTRACTOR** engaged on a public work and each subcontractor engaged on the public work shall keep or cause to be kept:

# CONSTRUCTION INDEPENDENT CONTRACTOR AGREEMENT

Contract No: 23300231

## Title: Juvenile Courts HVAC Replacement Project

(a) An accurate record showing, for each worker employed by the contractor or subcontractor in connection with the public work:

- (1) The name of the worker;
- (2) The occupation of the worker;
- (3) The gender of the worker, if the worker voluntarily agreed to specify that information pursuant to subsection 4, or an entry indicating that the worker declined to specify such information;
- (4) The ethnicity of the worker, if the worker voluntarily agreed to specify that information pursuant to subsection 4, or an entry indicating that the worker declined to specify such information;
- (5) If the worker has a driver's license or identification card, an indication of the state or other jurisdiction that issued the license or card; and
- (6) The actual per diem, wages and benefits paid to the worker; and

(b) An additional accurate record showing, for each worker employed by the contractor or subcontractor in connection with the public work who has a driver's license or identification card:

- (1) The name of the worker;
- (2) The driver's license number or identification card number of the worker; and
- (3) The state or other jurisdiction that issued the license or card.

7.3.3 The original payroll records shall be certified and shall be submitted weekly to Carson City Public Works, 3505 Butti Way, Carson City, Nevada 89703, attention Davis-Bacon/Federal Funding Compliance. Submission of such certified payrolls shall be a condition precedent for processing the monthly progress payment. **CONTRACTOR**, as General Contractor, shall collect the wage reports from the subcontractors and ensure the receipt of a certified copy of each weekly payroll for submission to **CITY** as one complete package.

7.3.4 Pursuant to NRS 338.060 and 338.070, **CONTRACTOR** hereby agrees to forfeit, as a penalty to **CITY**, not less than Twenty Dollars (\$20) nor more than Fifty Dollars (\$50) for each calendar day or portion thereof that each worker employed on the Contract is paid less than the designated rate for any WORK done under the Contract, by **CONTRACTOR** or any subcontractor under him/her, or is not reported to **CITY** as required by NRS 338.070.

## 8. **FAIR EMPLOYMENT PRACTICES:**

8.1 Pursuant to NRS 338.125, Fair Employment Practices, the following provisions must be included in any contract between **CONTRACTOR** and a public body such as **CITY**:

8.1.1 *In connection with the performance of work under this Contract, **CONTRACTOR** agrees not to discriminate against any employee or applicant for employment because of race, creed, color, national origin, sex, sexual orientation, gender identity, or age, including, without limitation, with regard to employment, upgrading, demotion or transfer, recruitment or recruitment advertising, layoff or termination, rates of pay or other forms of compensation, and selection for training, including without limitation, apprenticeship.*

8.1.2 **CONTRACTOR** further agrees to insert this provision in all subcontracts hereunder, except subcontracts for standard commercial supplies or raw materials.

# CONSTRUCTION INDEPENDENT CONTRACTOR AGREEMENT

Contract No: 23300231

## Title: Juvenile Courts HVAC Replacement Project

8.2 If the CITY was required by NRS 332.065(4) to advertise or request a proposal for this Agreement, by signing this Agreement, the CONTRACTOR provides a written certification that the CONTRACTOR is not currently engaged in, and during the Term shall not engage in, a Boycott of Israel. The term "Boycott of Israel" has the meaning ascribed to that term in Section 3 of Nevada Senate Bill 26 (2017). The CONTRACTOR shall be responsible for fines, penalties, and payment of any State of Nevada or federal funds that may arise (including those that the CITY pays, becomes liable to pay, or becomes liable to repay) as a direct result of the CONTRACTOR's non-compliance with this Section.

### 9. PREFERENTIAL EMPLOYMENT:

9.1 Unless, and except if, this Contract is funded in whole or in part by federal grant funding (see 40 C.F.R. § 31.36(c) *Competition*), pursuant to NRS 338.130, in all cases where persons are employed in the construction of public works, preference must be given, the qualifications of the applicants being equal: (1) First: To persons who have been honorably discharged from the Army, Navy, Air Force, Marine Corps or Coast Guard of the United States, a reserve component thereof or the National Guard; and are citizens of the State of Nevada. (2) Second: To other citizens of the State of Nevada.

9.2 Unless, and except if, this Contract is funded in whole or in part by federal grant funding (see 40 CFR § 31.36(c) *Competition*), in connection with the performance of WORK under this Contract, **CONTRACTOR** agrees to comply with the provisions of NRS 338.130 requiring certain preferences to be given to which persons are employed in the construction of a public work. If **CONTRACTOR** fails to comply with the provisions of NRS 338.130, pursuant to the terms of NRS 338.130(3), this Contract is void, and any failure or refusal to comply with any of the provisions of this section renders this Contract void.

### 10. REMEDIES:

Except as otherwise provided for by law or this Contract, the rights and remedies of the parties shall not be exclusive and are in addition to any other rights and remedies provided by law or equity, including, without limitation, actual damages, and to a prevailing party reasonable attorney's fees and costs. The parties agree that, in the event a lawsuit is filed and a party is awarded attorney's fees by the court, for any reason, the amount of recoverable attorney's fees shall not exceed the rate of \$125 per hour. **CITY** may set off consideration against any unpaid obligation of **CONTRACTOR** to **CITY**.

### 11. LIMITED LIABILITY:

**CITY** will not waive and intends to assert available NRS Chapter 41 liability limitations in all cases. Contract liability of both parties shall not be subject to punitive damages. Liquidated damages shall not apply unless otherwise expressly provided for elsewhere in this Contract. Damages for any **CITY** breach shall never exceed the amount of funds appropriated for payment under this Contract, but not yet paid to **CONTRACTOR**, for the fiscal year budget in existence at the time of the breach. **CONTRACTOR'S** tort liability shall not be limited.

### 12. FORCE MAJEURE:

Neither party shall be deemed to be in violation of this Contract if it is prevented from performing any of its obligations hereunder due to strikes, failure of public transportation, civil or military authority, act of public enemy, accidents, fires, explosions, or acts of God, including, without limitation, earthquakes, floods, winds, or storms. In such an event the intervening cause must not be through the fault of the party asserting such an excuse, and the excused party is obligated to promptly perform in accordance with the terms of this Contract after the intervening cause ceases.

### 13. INDEMNIFICATION:

13.1 To the extent permitted by law, including, but not limited to, the provisions of NRS Chapter 41, each party shall indemnify, hold harmless and defend, not excluding the other's right to participate, the other party from and against all liability, claims, actions, damages, losses, and expenses, including but not limited to reasonable attorney's fees and costs, arising out of any alleged negligent or willful acts or omissions of the indemnifying party, its officers, employees and agents. Such obligation shall not be construed to negate, abridge, or otherwise reduce any other right or obligation of the indemnity which

# CONSTRUCTION INDEPENDENT CONTRACTOR AGREEMENT

Contract No: 23300231

## Title: Juvenile Courts HVAC Replacement Project

would otherwise exist as to any party or person described in this Section.

13.2 Except as otherwise provided in **Subsection 13.4** below, the indemnifying party shall not be obligated to provide a legal defense to the indemnified party, nor reimburse the indemnified party for the same, for any period occurring before the indemnified party provides written notice of the pending claim(s) or cause(s) of action to the indemnifying party, along with:

13.2.1 a written request for a legal defense for such pending claim(s) or cause(s) of action; and

13.2.2 a detailed explanation of the basis upon which the indemnified party believes that the claim or cause of action asserted against the indemnified party implicates the culpable conduct of the indemnifying party, its officers, employees, and/or agents.

13.3 After the indemnifying party has begun to provide a legal defense for the indemnified party, the indemnifying party shall not be obligated to fund or reimburse any fees or costs provided by any additional counsel for the indemnified party, including counsel through which the indemnified party might voluntarily choose to participate in its defense of the same matter.

13.4 After the indemnifying party has begun to provide a legal defense for the indemnified party, the indemnifying party shall be obligated to reimburse the reasonable attorney's fees and costs incurred by the indemnified party during the initial thirty (30) day period of the claim or cause of action, if any, incurred by separate counsel.

#### 14. **INDEPENDENT CONTRACTOR:**

14.1 **CONTRACTOR**, as an independent contractor, is a natural person, firm or corporation who agrees to perform WORK for a fixed price according to his or its own methods and without subjection to the supervision or control of the **CITY**, except as to the results of the WORK, and not as to the means by which the WORK are accomplished.

14.2 It is mutually agreed that **CONTRACTOR** is associated with **CITY** only for the purposes and to the extent specified in this Contract, and in respect to performance of the contracted WORK pursuant to this Contract. **CONTRACTOR** is and shall be an independent contractor and, subject only to the terms of this Contract, shall have the sole right to supervise, manage, operate, control, and direct performance of the details incident to its duties under this Contract.

14.3 Nothing contained in this Contract shall be deemed or construed to create a partnership or joint venture, to create relationships of an employer-employee or principal-agent, or to otherwise create any liability for **CITY** whatsoever with respect to the indebtedness, liabilities, and obligations of **CONTRACTOR** or any other party.

14.4 **CONTRACTOR**, in addition to **Section 13** (INDEMNIFICATION), shall indemnify and hold **CITY** harmless from, and defend **CITY** against, any and all losses, damages, claims, costs, penalties, liabilities, expenses arising out of or incurred in any way because of, but not limited to, **CONTRACTOR'S** obligations or legal duties regarding any taxes, fees, assessments, benefits, entitlements, notice of benefits, employee's eligibility to work, to any third party, subcontractor, employee, state, local or federal governmental entity.

14.5 Neither **CONTRACTOR** nor its employees, agents, or representatives shall be considered employees, agents, or representatives of **CITY**.

#### 15. **INSURANCE REQUIREMENTS (GENERAL):**

**15.1 NOTICE: The following general insurance requirements shall apply unless these general requirements are altered by the specific requirements set forth in CITY'S solicitation for bid document, the adopted bid or other document incorporated into this Contract by the parties. These general insurance requirements do not include terms related to bond(s) required for this Contract, which are set forth in the CITY'S solicitation and below in this Contract following the execution pages.**

15.2 **CONTRACTOR**, as an independent contractor and not an employee of **CITY**, must carry policies of insurance in amounts specified and pay all taxes and fees incident hereunto. **CITY** shall have no liability except as specifically provided in this Contract.



# CONSTRUCTION INDEPENDENT CONTRACTOR AGREEMENT

Contract No: 23300231

## Title: Juvenile Courts HVAC Replacement Project

15.3 **CONTRACTOR** shall not commence work before: (1) **CONTRACTOR** has provided the required evidence of insurance to **CITY** Purchasing and Contracts, and (2) **CITY** has approved the insurance policies provided by **CONTRACTOR**.

15.4 Prior approval of the insurance policies by **CITY** shall be a condition precedent to any payment of consideration under this Contract and **CITY'S** approval of any changes to insurance coverage during the course of performance shall constitute an ongoing condition subsequent this Contract. Any failure of **CITY** to timely approve shall not constitute a waiver of the condition.

15.5 *Insurance Coverage (15.6 through 15.23):*

15.6 **CONTRACTOR** shall, at **CONTRACTOR'S** sole expense, procure, maintain and keep in force for the duration of this Contract the following insurance conforming to the minimum requirements specified below. Unless specifically specified herein or otherwise agreed to by **CITY**, the required insurance shall be in effect prior to the commencement of work by **CONTRACTOR** and shall continue in force as appropriate until the later of:

15.6.1 Final acceptance by **CITY** of the completion of this Contract; or

15.6.2 Such time as the insurance is no longer required by **CITY** under the terms of this Contract.

15.6.3 Any insurance or self-insurance available to **CITY** under its coverage(s) shall be in excess of and non-contributing with any insurance required from **CONTRACTOR**. **CONTRACTOR'S** insurance policies shall apply on a primary basis. Until such time as the insurance is no longer required by **CITY**, **CONTRACTOR** shall provide **CITY** with renewal or replacement evidence of insurance no less than thirty (30) calendar days before the expiration or replacement of the required insurance. If at any time during the period when insurance is required by this Contract, an insurer or surety shall fail to comply with the requirements of this Contract, as soon as **CONTRACTOR** has knowledge of any such failure, **CONTRACTOR** shall immediately notify **CITY** and immediately replace such insurance or bond with an insurer meeting the requirements.

15.7 *General Insurance Requirements (15.8 through 15.23):*

15.8 **Certificate Holder:** Each certificate shall list Carson City c/o Carson City Purchasing and Contracts, 201 N. Carson Street, Suite 2, Carson City, NV 89701 as a certificate holder.

15.9 **Additional Insured:** By endorsement to the general liability insurance policy evidenced by **CONTRACTOR**, The City and County of Carson City, Nevada, its officers, employees and immune contractors shall be named as additional insureds for all liability arising from this Contract.

15.10 **Waiver of Subrogation:** Each liability insurance policy, except for professional liability, shall provide for a waiver of subrogation in favor of the City.

15.11 **Cross-Liability:** All required liability policies shall provide cross-liability coverage as would be achieved under the standard ISO separation of insureds clause.

15.12 **Deductibles and Self-Insured Retentions:** Insurance maintained by **CONTRACTOR** shall apply on a first dollar basis without application of a deductible or self-insured retention unless otherwise specifically agreed to by **CITY**. Such approval shall not relieve **CONTRACTOR** from the obligation to pay any deductible or self-insured retention. Any deductible or self-insured retention shall not exceed \$5,000.00 per occurrence, unless otherwise approved by **CITY**.

15.13 **Policy Cancellation:** Except for ten (10) calendar days notice for non-payment of premium, **CONTRACTOR** or its insurers must provide thirty (30) calendar days prior written notice to Carson City Purchasing and Contracts if any policy will be canceled, non-renewed or if required coverage and /or limits reduced or materially altered, and shall provide that notices required by this paragraph shall be sent by mail to Carson City Purchasing and Contracts, 201 N. Carson Street, Suite 2, Carson City, NV 89701. When available, each insurance policy shall be endorsed to provide thirty (30) days' notice of cancellation, except for ten (10) days' notice for non-payment of premium, to City.

# CONSTRUCTION INDEPENDENT CONTRACTOR AGREEMENT

**Contract No: 23300231**

## **Title: Juvenile Courts HVAC Replacement Project**

15.14 **Approved Insurer:** Each insurance policy shall be issued by insurance companies authorized to do business in the State of Nevada or eligible surplus lines insurers under federal and Nevada law and having agents in Nevada upon whom service of process may be made, and currently rated by A.M. Best as "A-VII" or better.

15.15 **Evidence of Insurance:** Prior to commencement of work, **CONTRACTOR** must provide the following documents to Carson City Purchasing and Contracts, 201 North Carson Street, Suite 2, Carson City, NV 89701:

15.16 **Certificate of Insurance:** Contractor shall furnish City with a certificate(s) of insurance, executed by a duly authorized representative of each insurer, showing compliance with the insurance requirements set forth herein. The Acord 25 Certificate of Insurance form or a form substantially similar must be submitted to Carson City Purchasing and Contracts to evidence the insurance policies and coverages required of **CONTRACTOR**.

15.17 **Additional Insured Endorsement:** An Additional Insured Endorsement (CG20 10 or C20 26), signed by an authorized insurance company representative, must be submitted to Carson City Purchasing and Contracts to evidence the endorsement of **CITY** as an additional insured per **Subsection 15.9** (Additional Insured).

15.18 **Schedule of Underlying Insurance Policies:** If Umbrella or Excess policy is evidenced to comply with minimum limits, a copy of the Underlying Schedule from the Umbrella or Excess insurance policy may be required.

15.19 **Review and Approval:** Documents specified above must be submitted for review and approval by **CITY** Purchasing and Contracts prior to the commencement of work by **CONTRACTOR**. Neither approval by **CITY** nor failure to disapprove the insurance furnished by **CONTRACTOR** shall relieve **CONTRACTOR** of **CONTRACTOR'S** full responsibility to provide the insurance required by this Contract. Compliance with the insurance requirements of this Contract shall not limit the liability of **CONTRACTOR** or its sub-contractors, employees or agents to **CITY** or others, and shall be in addition to and not in lieu of any other remedy available to **CITY** under this Contract or otherwise. **CITY** reserves the right to request and review a copy of any required insurance policy or endorsement to assure compliance with these requirements.

### 15.20 **COMMERCIAL GENERAL LIABILITY INSURANCE:**

Contractor shall maintain commercial general liability (CGL) and, if necessary, commercial umbrella insurance with a limit of not less than \$1,000,000 each occurrence.

15.20.1 *Minimum Limits required:*

15.20.2 Two Million Dollars (\$2,000,000.00) - General Aggregate.

15.20.3 Two Million Dollars (\$2,000,000.00) - Products & Completed Operations. Aggregate

15.20.4 One Million Dollars (\$1,000,000.00) - Each Occurrence.

15.20.5 CGL insurance shall be written on ISO occurrence form CG 00 01 04 13 (or a substitute form providing equivalent coverage) and shall cover liability arising from premises, operations, products-completed operations, personal and advertising injury, and liability assumed under an insured contract [(including the tort liability of another assumed in a business contract)].

15.20.6 City and County of Carson City, Nevada, its officers, employees and immune contractors shall be included as an insured under the CGL, using ISO additional insured endorsement CG 20 10 or CG 20 26, or a substitute providing equivalent coverage, and under the commercial umbrella, if any.

15.20.7 This insurance shall apply as primary insurance with respect to any other insurance or self-insurance programs afforded to City. There shall be no endorsement or modification of the CGL to make it excess over other available

# CONSTRUCTION INDEPENDENT CONTRACTOR AGREEMENT

Contract No: 23300231

## Title: Juvenile Courts HVAC Replacement Project

insurance; alternatively, if the CGL states that it is excess or pro rata, the policy shall be endorsed to be primary with respect to the additional insured.

15.20.8 There shall be no endorsement or modification of the CGL limiting the scope of coverage for liability assumed under a contract.

15.20.9 Contractor waives all rights against City and its agents, officers, directors and employees for recovery of damages to the extent these damages are covered by the commercial general liability or commercial umbrella liability insurance maintained pursuant to this Contract. Insurer shall endorse CGL policy as required to waive subrogation against City with respect to any loss paid under the policy

### 15.21 BUSINESS AUTOMOBILE LIABILITY INSURANCE:

15.21.1 *Minimum Limit required:*

15.21.2 Contractor shall maintain automobile liability and, if necessary, commercial umbrella liability insurance with a limit of not less than \$1,000,000 each accident for bodily injury and property damage.

15.21.3 Such insurance shall cover liability arising out of owned, hired, and non-owned autos (as applicable). Coverage as required above shall be written on ISO form CA 00 01, CA 00 05, CA 00 25, or a substitute form providing equivalent liability coverage.

15.21.4 Contractor waives all rights against City and its agents, officers, directors and employees for recovery of damages to the extent these damages are covered by the automobile liability or other liability insurance obtained by Contractor pursuant this Contract.

### 15.22 PROFESSIONAL LIABILITY INSURANCE (Architects, Engineers and Land Surveyors)

15.22.1 *Minimum Limit required:*

15.22.2 CONTRACTOR shall maintain professional liability insurance applying to all activities performed under this Contract with limits not less than One Million Dollars (\$1,000,000.00) and Two Million Dollars (\$2,000,000) in the aggregate.

15.22.3 Retroactive date: Prior to commencement of the performance of this Contract.

15.22.4 CONTRACTOR will maintain professional liability insurance during the term of this Contract and for a period of three (3) years after termination of this Contract unless waived by the City. In the event of non-renewal or other lapse in coverage during the term of this Contract or the three (3) year period described above, CONTRACTOR shall purchase Extended Reporting Period coverage for claims arising out of CONTRACTOR's negligence acts, errors and omissions committed during the term of the Professional Liability Policy. The Extended Reporting Period shall continue through a minimum of three (3) years after termination date of this Contract.

15.22.5 A certified copy of this policy may be required.

### 15.23 WORKERS' COMPENSATION AND EMPLOYER'S LIABILITY INSURANCE:

15.23.1 **CONTRACTOR** shall provide workers' compensation insurance as required by NRS Chapters 616A through 616D inclusive and Employer's Liability insurance with a minimum limit not less than \$1,000,000 each accident for bodily injury by accident or \$1,000,000 each employee for bodily injury by disease

15.23.2 **CONTRACTOR** may, in lieu of furnishing a certificate of an insurer, provide an affidavit indicating that **CONTRACTOR** is a sole proprietor; that **CONTRACTOR** will not use the services of any employees in the performance of this Contract; that **CONTRACTOR** has elected to not be included in the terms, conditions, and provisions of NRS Chapters 616A-616D, inclusive; and that

# CONSTRUCTION INDEPENDENT CONTRACTOR AGREEMENT

Contract No: 23300231

## Title: Juvenile Courts HVAC Replacement Project

**CONTRACTOR** is otherwise in compliance with the terms, conditions, and provisions of NRS Chapters 616A-616D, inclusive.

15.23.3 **CONTRACTOR** waives all rights against City and its agents, officers, directors, and employees for recovery of damages to the extent these damages are covered by the workers' compensation and employer's liability or commercial umbrella liability insurance obtained by Contractor pursuant to this Contract. Contractor shall obtain an endorsement equivalent to WC 00 03 13 to affect this waiver.

### 16. BUSINESS LICENSE:

16.1 **CONTRACTOR** shall not commence work before **CONTRACTOR** has provided a copy of his Carson City business license to Carson City Purchasing and Contracts.

16.2 The Carson City business license shall continue in force until the later of: (1) final acceptance by **CITY** of the completion of this Contract; or (2) such time as the Carson City business license is no longer required by **CITY** under the terms of this Contract.

### 17. COMPLIANCE WITH LEGAL OBLIGATIONS:

**CONTRACTOR** shall procure and maintain for the duration of this Contract any state, county, city, or federal license, authorization, waiver, permit, qualification or certification required by statute, ordinance, law, or regulation to be held by **CONTRACTOR** to provide the goods or WORK or any services of this Contract. **CONTRACTOR** will be responsible to pay all government obligations, including, but not limited to, all taxes, assessments, fees, fines, judgments, premiums, permits, and licenses required or imposed by law or a court. Real property and personal property taxes are the responsibility of **CONTRACTOR** in accordance with NRS Chapter 361 generally and NRS 361.157 and 361.159, specifically regarding for profit activity. **CONTRACTOR** agrees to be responsible for payment of any such government obligations not paid by its subcontractors during performance of this Contract. **CITY** may set-off against consideration due any delinquent government obligation.

### 18. WAIVER OF BREACH:

Failure to declare a breach or the actual waiver of any particular breach of this Contract or its material or nonmaterial terms by either party shall not operate as a waiver by such party of any of its rights or remedies as to any other breach.

### 19. SEVERABILITY:

If any provision contained in this Contract is held to be unenforceable by a court of law or equity, this Contract shall be construed as if such provision did not exist and the nonenforceability of such provision shall not be held to render any other provision or provisions of this Contract unenforceable.

### 20. ASSIGNMENT / DELEGATION:

To the extent that any assignment of any right under this Contract changes the duty of either party, increases the burden or risk involved, impairs the chances of obtaining the performance of this Contract, attempts to operate as a novation, or includes a waiver or abrogation of any defense to payment by **CITY**, such offending portion of the assignment shall be void, and shall be a breach of this Contract. **CONTRACTOR** shall neither assign, transfer nor delegate any rights, obligations or duties under this Contract without the prior written approval of **CITY**. The parties do not intend to benefit any third party beneficiary regarding their respective performance under this Contract.

### 21. CITY OWNERSHIP OF PROPRIETARY INFORMATION:

21.1 Any files, reports, histories, studies, tests, manuals, instructions, photographs, negatives, blue prints, plans, maps, data, system designs, computer programs, computer codes, and computer records (which are intended to be consideration under this Contract), or any other documents or drawings, prepared or in the course of preparation by **CONTRACTOR** (or its subcontractors) in performance of its obligations under this Contract shall be the exclusive property of **CITY** and all such materials shall be delivered into **CITY** possession by **CONTRACTOR** upon completion, termination, or cancellation of this Contract. **CONTRACTOR** shall not use, willingly allow, or cause to have such materials used for any

# CONSTRUCTION INDEPENDENT CONTRACTOR AGREEMENT

Contract No: 23300231

## Title: Juvenile Courts HVAC Replacement Project

purpose other than performance of **CONTRACTOR'S** obligations under this Contract without the prior written consent of **CITY**. Notwithstanding the foregoing, **CITY** shall have no proprietary interest in any materials licensed for use by **CITY** that are subject to patent, trademark or copyright protection.

21.2 **CITY** shall be permitted to retain copies, including reproducible copies, of **CONTRACTOR'S** drawings, specifications, and other documents for information and reference in connection with this Contract.

21.3 **CONTRACTOR'S** drawings, specifications and other documents shall not be used by **CITY** or others without expressed permission of **CONTRACTOR**.

### 22. PUBLIC RECORDS:

Pursuant to NRS 239.010, information or documents received from **CONTRACTOR** may be open to public inspection and copying. **CITY** will have the duty to disclose unless a particular record is made confidential by law or a common law balancing of interests. **CONTRACTOR** may clearly label specific parts of an individual document as a "trade secret" or "confidential" in accordance with NRS 332.061, provided that **CONTRACTOR** thereby agrees to indemnify and defend **CITY** for honoring such a designation. The failure to so label any document that is released by **CITY** shall constitute a complete waiver of any and all claims for damages caused by any release of the records.

### 23. CONFIDENTIALITY:

**CONTRACTOR** shall keep confidential all information, in whatever form, produced, prepared, observed or received by **CONTRACTOR** to the extent that such information is confidential by law or otherwise required by this Contract.

### 24. FEDERAL FUNDING:

24.1 *In the event federal grant funds are used for payment of all or part of this Contract:*

24.1.1 **CONTRACTOR** certifies, by signing this Contract, that neither it nor its principals are presently debarred, suspended, proposed for debarment, declared ineligible, or voluntarily excluded from participation in this transaction by any federal department or agency. This certification is made pursuant to the regulations implementing Executive Order 12549, Debarment and Suspension, 28 C.F.R. pt. 67, § 67.510, as published as pt. VII of the May 26, 1988, Federal Register (pp. 19160-19211), and any relevant program-specific regulations. This provision shall be required of every subcontractor receiving any payment in whole or in part from federal funds.

24.1.2 **CONTRACTOR** and its subcontractors must be registered in the US Government System for Award Management (SAM) for verification on projects with federal funding.

24.1.3 **CONTRACTOR** and its subcontractors shall comply with all terms, conditions, and requirements of the Americans with Disabilities Act of 1990 (P.L. 101-136), 42 U.S.C. 12101, as amended, and regulations adopted thereunder contained in 28 C.F.R. 26.101-36.999, inclusive, and any relevant program-specific regulations.

24.1.4 **CONTRACTOR** and its subcontractors shall comply with the requirements of the Civil Rights Act of 1964, as amended, the Rehabilitation Act of 1973, P.L. 93-112, as amended, and any relevant program-specific regulations, and Executive Order 11478 (July 21, 2014) and shall not discriminate against any employee or offeror for employment because of race, national origin, creed, color, sex, sexual orientation, gender identity, religion, age, disability or handicap condition (including AIDS and AIDS-related conditions).

24.14.1 If and when applicable to the particular federal funding and the Scope of Work under this Contract, **CONTRACTOR** and its subcontractors shall comply with: American Iron and Steel (AIS) provisions of P.L. 113-76, Consolidated Appropriations Act, 2014, Section 1605 – Buy American (100% Domestic Content of iron, steel and manufactured goods); Federal Highway Administration (FHWA) 23 U.S.C. § 313 – Buy America, 23 C.F.R.

# CONSTRUCTION INDEPENDENT CONTRACTOR AGREEMENT

Contract No: 23300231

## Title: Juvenile Courts HVAC Replacement Project

§635.410 (100% Domestic Content of steel, iron and manufactured products); Federal Transit Administration (FTA)49 U.S.C. § 5323(j), 49 C.F.R. Part 661 – Buy America Requirements (See 60% Domestic Content for buses and other Rolling Stock).

### 25. LOBBYING:

25.1 The parties agree, whether expressly prohibited by federal law, or otherwise, that no funding associated with this Contract will be used for any purpose associated with or related to lobbying or influencing or attempting to lobby or influence for any purpose the following:

25.1.1 Any federal, state, county or local agency, legislature, commission, council or board;

25.1.2 Any federal, state, county or local legislator, commission member, council member, board member, or other elected official; or

25.1.3 Any officer or employee of any federal, state, county or local agency; legislature, commission, council or board.

### 26. GENERAL WARRANTY:

**CONTRACTOR** warrants that it will perform all WORK required hereunder in accordance with the prevailing standard of care by exercising the skill and care normally required of individuals performing the same or similar WORK, under the same or similar circumstances, in the State of Nevada.

### 27. PROPER AUTHORITY:

The parties hereto represent and warrant that the person executing this Contract on behalf of each party has full power and authority to enter into this Contract. **CONTRACTOR** acknowledges that this Contract is effective only after approval by the Carson City Board of Supervisors and only for the period of time specified in this Contract. Any WORK performed by **CONTRACTOR** before this Contract is effective or after it ceases to be effective is performed at the sole risk of **CONTRACTOR**.

### 28. ALTERNATIVE DISPUTE RESOLUTION (Public Work):

If the WORK under this Contract involves a “public work” as defined under NRS 338.010(18), then pursuant to NRS 338.150, a public body charged with the drafting of specifications for a public work shall include in the specifications a clause requiring the use of a method of alternative dispute resolution (“ADR”) before initiation of a judicial action if a dispute arising between the public body and the **CONTRACTOR** engaged on the public work cannot otherwise be settled. Therefore, unless ADR is otherwise provided for by the parties in any other incorporated attachment to this Contract, in the event that a dispute arising between **CITY** and **CONTRACTOR** regarding that public work cannot otherwise be settled, **CITY** and **CONTRACTOR** agree that, before judicial action may be initiated, **CITY** and **CONTRACTOR** will submit the dispute to non-binding mediation. **CITY** shall present **CONTRACTOR** with a list of three potential mediators. **CONTRACTOR** shall select one person to serve as the mediator from the list of potential mediators presented by **CITY**. The person selected as mediator shall determine the rules governing the mediation.

### 29. GOVERNING LAW / JURISDICTION:

This Contract and the rights and obligations of the parties hereto shall be governed by, and construed according to, the laws of the State of Nevada, without giving effect to any principle of conflict-of-law that would require the application of the law of any other jurisdiction. **CONTRACTOR** consents and agrees to the jurisdiction of the courts of the State of Nevada located in Carson City, Nevada for enforcement of this Contract.

### 30. ENTIRE CONTRACT AND MODIFICATION:

This Contract and its integrated attachment(s) constitute the entire Contract of the parties and such are intended as a complete and exclusive statement of the promises, representations, negotiations, discussions, and other Contracts that may have been made in connection with the subject matter hereof. Unless an integrated attachment to this Contract specifically displays a mutual intent to amend a particular part of this Contract, general conflicts in language between any such attachment and this Contract shall be construed consistent with the terms of this Contract. Unless otherwise expressly authorized by the terms of this Contract, no modification or amendment to this Contract shall be binding upon the parties unless the same is in writing and signed by the respective parties hereto and approved by the Carson City Board of Supervisors. Conflicts in language between

# CONSTRUCTION INDEPENDENT CONTRACTOR AGREEMENT

Contract No: 23300231

## Title: Juvenile Courts HVAC Replacement Project

this Contract and any other agreement between CITY and CONTRACTOR on this same matter shall be construed consistent with the terms of this Contract. The parties agree that each has had their respective counsel review this Contract which shall be construed as if it was jointly drafted.

### 31. ACKNOWLEDGMENT AND EXECUTION:

This Contract may be executed in counterparts. The parties hereto have caused this Contract to be signed and intend to be legally bound thereby as follows:

**AND ALL SUPPLEMENTAL AGREEMENTS AMENDING OR EXTENDING THE WORK CONTEMPLATED.**

### **ACKNOWLEDGMENT AND EXECUTION:**

In witness whereof, the parties hereto have caused this Contract to be signed and intend to be legally bound thereby.

#### **CITY**

Executive Office  
Purchasing and Contracts Department  
201 North Carson Street, Suite 2  
Carson City, Nevada 89701  
Telephone: 775-283-7362  
Fax: 775-887-2286  
[CAkers@carson.org](mailto:CAkers@carson.org)

#### **CITY'S LEGAL COUNSEL**

Carson City District Attorney  
I have reviewed this Contract and approve  
as to its legal form.

By: \_\_\_\_\_  
Sheri Russell-Benabou, Chief Financial Officer

By: \_\_\_\_\_  
Deputy District Attorney

Dated \_\_\_\_\_

Dated \_\_\_\_\_

**CONTRACTOR will not be given authorization  
to begin work until this Contract has been  
signed by Purchasing and Contracts**

BY: Carol Akers  
Purchasing & Contracts Administrator

Project# P303423202  
Account # 3403034-507010

By: \_\_\_\_\_

Dated \_\_\_\_\_

### **PROJECT CONTACT PERSON:**

Michael Friend, Project Manager  
Telephone: 775-283-7713

**CONSTRUCTION INDEPENDENT CONTRACTOR AGREEMENT**

**Contract No: 23300231**

**Title: Juvenile Courts HVAC Replacement Project**

**Undersigned** deposes and says under penalty of perjury: That he/she is **CONTRACTOR** or authorized agent of **CONTRACTOR**; that he/she has read the foregoing Contract; and that he/she understands the terms, conditions and requirements thereof.

**CONTRACTOR**

**BY:** Hugh Palmer

**TITLE:** Assistant Secretary

**FIRM:** ACCO Engineered Systems, Inc.

**CARSON CITY BUSINESS LICENSE #:** BL-006367-2021

**NEVADA CONTRACTORS LICENSE #:** 0002549/0055552/0083321

**Address:** 2010 Kleppe Lane

**City:** Sparks **State:** NV **Zip Code:** 89431

**Telephone:** 818-244-6571

**E-mail Address:** [hpalmer@accoes.com](mailto:hpalmer@accoes.com)

\_\_\_\_\_  
(Signature of Contractor)

**DATED** \_\_\_\_\_

**STATE OF** \_\_\_\_\_ )

)ss

**County of** \_\_\_\_\_ )

Signed and sworn (or affirmed before me on this \_\_\_\_\_ day of \_\_\_\_\_, 20\_\_\_\_.

\_\_\_\_\_  
(Signature of Notary)

(Notary Stamp)



# CONSTRUCTION INDEPENDENT CONTRACTOR AGREEMENT

**Contract No: 23300231**

**Title: Juvenile Courts HVAC Replacement Project**

## CONTRACT ACCEPTANCE AND EXECUTION:

The Board of Supervisors for Carson City, Nevada at their publicly noticed meeting of March 2, 2023, approved the acceptance of the attached Contract hereinbefore identified as **CONTRACT No. 23300231** and titled **Juvenile Courts HVAC Replacement Project**. Further, the Board of Supervisors authorizes the Mayor of Carson City, Nevada to sign this document and record the signature for the execution of this Contract in accordance with the action taken.

**CARSON CITY, NEVADA**

\_\_\_\_\_  
LORI BAGWELL, MAYOR

DATED this 2nd day of March 2023.

**ATTEST:**

\_\_\_\_\_  
WILLIAM SCOTT HOEN, CLERK-RECORDER

DATED this 2nd day of March 2023.

# PERFORMANCE BOND

Doc. No. 2151  
(Rev. 11-17-99)

Bond #: \_\_\_\_\_

**KNOW ALL PERSONS BY THESE PRESENTS**, that I/we \_\_\_\_\_  
\_\_\_\_\_ as Principal, hereinafter called CONTRACTOR,  
and

\_\_\_\_\_ a corporation duly organized under the laws of \_\_\_\_\_, as Surety, hereinafter called the Surety, are held and firmly bound unto Carson City, Nevada a consolidated municipality of the State of Nevada, hereinafter called CITY, for the sum of \$ \_\_\_\_\_ (state sum in Words) \_\_\_\_\_ for the payment whereof CONTRACTOR and Surety bind themselves, their heirs, executors, administrators, successors and assigns, jointly and severally, firmly by these presents.

**WHEREAS**, CONTRACTOR has by written agreement dated \_\_\_\_\_, entered into a contract with CITY for **BID# 23300231** and titled **Juvenile Courts HVAC Replacement Project** in accordance with drawings and specifications prepared by CITY and which contract is by reference made a part hereof, and is hereinafter referred to as the Contract.

**NOW, THEREFORE, THE CONDITION OF THIS OBLIGATION** is such that, if CONTRACTOR shall promptly and faithfully perform said Contract then this obligation shall be null and void; otherwise it shall remain in full force and effect. The Surety hereby waives notice of any alteration or extension of time made by CITY and its obligation is not affected by any such alteration or extension provided the same is within the scope of the Contract. Whenever CONTRACTOR shall be, and is declared by CITY to be in default under the Contract, CITY having performed CITY'S obligations thereunder, the Surety may promptly remedy the default or shall promptly:

- 1) Complete the Contract in accordance with its terms and conditions; or
- 2) Obtain a bid or bids for completing the Contract in accordance with its terms and conditions, and upon determination by CITY and the Surety jointly of the lowest responsive, responsible bidder, arrange for a contract between such bidder and CITY, and make available as work progresses (even though there should be a default or a succession of defaults under the contract or contracts of completion arranged under this paragraph) sufficient funds to pay the cost of completion less the balance of the Contract price, but not exceeding, including other costs and damages for which the Surety may be liable hereunder, the amount set forth in the first paragraph hereof. The term "balance of the Contract price", as used in this paragraph, shall mean the total amount payable by CITY to CONTRACTOR under the Contract and any amendments thereto, less the amount properly paid by CITY to CONTRACTOR. No right of action shall accrue on this bond to or for the use of any person or corporation other than CITY or successors of CITY.

# PERFORMANCE BOND

Continued for **BID# 23300231** and titled **Juvenile Courts HVAC Replacement Project**

<b>BY:</b>	(Signature of Principal)        L.S.
<b>TITLE:</b>	
<b>FIRM:</b>	
<b>Address:</b>	
<b>City, State, Zip:</b>	
<b>Phone:</b>	
<b>Printed Name of Principal:</b>	
<b>Attest By:</b>	(Signature of Notary)
Subscribed and Sworn before me this         day of         ,20____	

**CLAIMS UNDER THIS BOND  
MAY BE ADDRESSED TO:**

<b>Name of Surety:</b>	
<b>Address:</b>	
<b>City:</b>	
<b>State/Zip Code:</b>	
<b>Name:</b>	
<b>Title:</b>	
<b>Telephone:</b>	
<b>Surety's Acknowledgment:</b>	
<b>By:</b>	

**NOTICE:**

No substitution or revision to this bond form will be accepted. Sureties must be authorized to do business in and have an agent for service of process in the State of Nevada. Certified copy of Power of Attorney must be attached.

# LABOR AND MATERIAL PAYMENT BOND

Bond #: \_\_\_\_\_

Doc. No. 2152  
(Rev. 11-17-99)

**KNOW ALL PERSONS BY THESE PRESENTS**, that I/we \_\_\_\_\_  
\_\_\_\_\_ as Principal, hereinafter called

CONTRACTOR, and

\_\_\_\_\_ a  
corporation duly organized under the laws of the State of Nevada, as Surety, hereinafter called the Surety, are held and firmly bound unto Carson City, Nevada a consolidated municipality of the State of Nevada, hereinafter called CITY, for the \$ \_\_\_\_\_ Dollars (state sum in words) \_\_\_\_\_

\_\_\_\_\_ for  
the payment whereof CONTRACTOR and Surety bind themselves, their heirs, executors, administrators, successors and assigns, jointly and severally, firmly by these presents.

**WHEREAS**, CONTRACTOR has by written agreement dated \_\_\_\_\_ entered into a contract with CITY for **BID# 23300231** and titled **Juvenile Courts HVAC Replacement Project** in accordance with drawings and specifications prepared by CITY and which contract is by reference made a part hereof, and is hereinafter referred to as the Contract.

**NOW, THEREFORE, THE CONDITION OF THIS OBLIGATION** is such that, if CONTRACTOR shall promptly make payment to all claimants as hereinafter defined, for all labor and material used or reasonably required for use in the performance of the Contract, then this obligation shall be void; otherwise it shall remain in full force and effect, subject, however, to the following conditions:

- 1) A claimant is defined as one having a direct contract with CONTRACTOR or with a Subcontractor of the Principal for labor, material, or both, used or reasonably required for use in the performance of the Contract, labor and material being construed to include that part of water, gas, power, light, heat, oil, gasoline, telephone service, or rental of equipment directly applicable to the Contract.
- 2) The above-named Principal and Surety hereby jointly and severally agree with CITY that every claimant as herein defined, who has not been paid in full before the expiration of a period of ninety (90) days after the date on which the last of such claimant's work or labor was done or performed, or materials were furnished by such claimant, may sue on this bond for the use of such claimant, prosecute the suit to final judgment for such sum or sums as may be justly due claimant, and have execution thereon. CITY shall not be liable for the payment of any costs or expenses of any such suit.
- 3) No suit or action shall be commenced hereunder by any claimant:
  - a) Unless claimant, other than one having a direct contract with CONTRACTOR, shall have given written notice to any two of the following: CONTRACTOR, CITY, or the Surety above named, within ninety (90) days after such claimant did or performed the last of the work or labor, or furnished the last of the materials for which said claim is made, stating with substantial accuracy the amount claimed and the name of the party to whom the materials were furnished, or for whom the work or labor was done or performed. Such notice shall be personally served or served by mailing the same by registered mail or certified mail, postage prepaid, in an envelope addressed to the Principal at any place the Principal maintains an office or conducts its business.
  - b) After the expiration of one (1) year following the date on which the last of the labor was performed or material was supplied by the party bringing suit.
  - c) Other than in a court of competent jurisdiction for the county or district in which the construction Contract was to be performed.

# LABOR AND MATERIAL PAYMENT BOND

Continued for **BID# 23300231** and titled **Juvenile Courts HVAC Replacement Project**

- 4) The amount of this bond shall be reduced by and to the extent of any payment or payments made in good faith hereunder, inclusive of the payment by Surety of mechanics' liens which may be filed of record against said improvement, whether or not claim for the amount of such lien be presented under and against this bond.

<b>BY:</b>	<b>(signature of Principal)</b>   <b>L.S.</b>	
<b>TITLE:</b>		
<b>FIRM:</b>		
<b>Address:</b>		
<b>City, State, Zip:</b>		
<b>Phone:</b>		
<b>Printed Name of Principal:</b>		
<b>Attest by:</b>	<b>(signature of notary)</b>	
<b>Subscribed and Sworn before me this</b>	<b>day of</b>	<b>, 20__</b>

**CLAIMS UNDER THIS BOND  
MAY BE ADDRESSED TO:**

<b>Name of Surety:</b>	
<b>Address:</b>	
<b>City:</b>	
<b>State/Zip Code:</b>	
<b>Name:</b>	
<b>Title:</b>	
<b>Telephone:</b>	
<b>Surety's Acknowledgment:</b>	
<b>By:</b>	

**NOTICE:**

No substitution or revision to this bond form will be accepted. Sureties must be authorized to do business in and have an agent for service of process in the State of Nevada. Certified copy of Power of Attorney must be attached.

**CITY OF CARSON CITY, NEVADA – BID BOND**

KNOW ALL MEN BY THESE PRESENTS: That we the undersigned ACCO Engineered Systems, Inc. as "Principal," and Fidelity And Deposit Company of Maryland as "Surety," are hereby held and firmly bound unto the City of Carson City, Nevada, as "Obligee," in the penal sum of Five Percent of Amount Bid dollars (\$ 5% of amount bid) for the payment of which, well and truly to be made, the Principal and Surety bind themselves, their heirs, executors, and administrators, successors and assigns, jointly and severally, by this instrument. The condition of the obligation of this bid bond is as follows:

WHEREAS, NRS 332.105 authorizes local governments to require bid bonds to insure execution and proper performance of the Contract and the Bonding Company has an "A" or better rating with Moody's or A.M. Best and T-Listed with the U.S. Treasury Department;

AND, WHEREAS, the Principal has submitted a bid for Bid # 23300231, PWP # CC-2023-082, for the Project Title: Juvenile Courts HVAC Replacement Project.

NOW, THEREFORE,

- (a) If said Bid shall be rejected; or
- (b) If said Bid shall be accepted and the Principal shall execute and deliver the contract in the bid documents ("Contract") to Obligee in accordance with the terms of the bid documents, and give such bond or bonds as may be specified in the bid or contract documents with good and sufficient surety for the faithful performance of such Contract and for the prompt payment of labor and material furnished in the prosecution thereof; or
- (c) If the Principal shall pay to the Obligee the full amount of the bid bond as a penalty irrespective of the Obligee's actual damages in the event of the failure of the Principal to enter into such Contract and give such bond or bonds,

then, this obligation shall be null and void. Otherwise it shall remain in full force and effect, it being expressly understood and agreed that the liability of the Surety (but not of the Principal) for any and all claims hereunder shall, in no event, exceed the penal amount of the obligation as herein stated

The Surety, for the consideration for which this bond was executed, hereby stipulates and agrees that the obligations of said Surety and its bond shall be in no way impaired or affected by any extension of the time within which the Obligee may accept such bid, and hereby waives notice of any such extension.

**IN WITNESS WHEREOF, the Principal and the Surety have hereunto set their hands and the Surety has caused their seal to be hereto affixed and these present to be signed by their proper officers.**

Signed, Sealed and dated: January 25, 2023

ACCO Engineered Systems, Inc.  
Principal  
By:  Hugh Palmer

Fidelity And Deposit Company of Maryland  
Surety  
By:  D. Garcia  
Assistant Secretary  
D. Garcia, Attorney-In-Fact

### ACKNOWLEDGMENT

A notary public or other officer completing this certificate verifies only the identity of the individual who signed the document to which this certificate is attached, and not the truthfulness, accuracy, or validity of that document.

State of California  
County of Los Angeles )

On February 1, 2023 before me, Hanh Nguyen, Notary Public  
(insert name and title of the officer)

personally appeared Hugh Palmer  
who proved to me on the basis of satisfactory evidence to be the person(s) whose name(s) is/are subscribed to the within instrument and acknowledged to me that he/she/they executed the same in his/her/their authorized capacity(ies), and that by his/her/their signature(s) on the instrument the person(s), or the entity upon behalf of which the person(s) acted, executed the instrument.

I certify under PENALTY OF PERJURY under the laws of the State of California that the foregoing paragraph is true and correct.

WITNESS my hand and official seal.



Signature  (Seal)

CALIFORNIA ALL-PURPOSE ACKNOWLEDGMENT

CIVIL CODE § 1189

A notary public or other officer completing this certificate verifies only the identity of the individual who signed the document to which this certificate is attached, and not the truthfulness, accuracy, or validity of that document.

State of California )

County of Los Angeles )

On JAN 25 2023 before me, Rachel A. Mullen, Notary Public
Date Here Insert Name and Title of the Officer

Personally appeared D. Garcia
Name(s) of Signer(s)

who proved to me on the basis of satisfactory evidence to be the person(s) whose name(s) is/are subscribed to the within instrument and acknowledged to me that he/she/they executed the same in his/her/their authorized capacity(ies), and that by his/her/their signature(s) on the instrument the person(s), or the entity upon behalf of which the person(s) acted, executed the instrument.

I certify under PENALTY OF PERJURY under the laws of the State of California that the foregoing paragraph is true and correct.

WITNESS my hand and official seal.



Signature [Handwritten Signature]
Signature of Notary Public

Place Notary Seal Above

OPTIONAL

Though this section is optional, completing this information can deter alteration of the document or fraudulent reattachment of this form to an unintended document.

Description of Attached Document

Title or Type of Document Document Date

Number of Pages Signer(s) Other Than Named Above

Capacity(ies) Claimed by Signer(s)

Signer's Name
[ ] Corporate Officer—Title(s)
[ ] Partner [ ] Limited [ ] General
[ ] Individual [ ] Attorney in Fact
[ ] Trustee [ ] Guardian or Conservator
[ ] Other

Signer's Name
[ ] Corporate Officer—Title(s)
[ ] Partner [ ] Limited [ ] General
[ ] Individual [ ] Attorney in Fact
[ ] Trustee [ ] Guardian or Conservator
[ ] Other

Signer Is Representing

Signer Is Representing



ZURICH AMERICAN INSURANCE COMPANY  
COLONIAL AMERICAN CASUALTY AND SURETY COMPANY  
FIDELITY AND DEPOSIT COMPANY OF MARYLAND  
POWER OF ATTORNEY

KNOW ALL MEN BY THESE PRESENTS: That the ZURICH AMERICAN INSURANCE COMPANY, a corporation of the State of New York, the COLONIAL AMERICAN CASUALTY AND SURETY COMPANY, a corporation of the State of Illinois, and the FIDELITY AND DEPOSIT COMPANY OF MARYLAND a corporation of the State of Illinois (herein collectively called the "Companies"), by **Robert D. Murray, Vice President**, in pursuance of authority granted by Article V, Section 8, of the By-Laws of said Companies, which are set forth on the reverse side hereof and are hereby certified to be in full force and effect on the date hereof, do hereby nominate, constitute, and appoint **B. ALEMAN, Ethan SPECTOR, Timothy NOONAN, Janina MONROE, Adriana VALENZUELA, Jennifer OCHS, Aidan SMOCK, Lisa CRAIL, Simon GERHARD, Erin BROWN, Paul RODRIGUEZ, Emily NEWELL, D. GARCIA, KD WAPATO, Marina TAPIA, Edward C. SPECTOR, Ethan SPECTOR of Los Angeles, California**, its true and lawful agent and Attorney-in-Fact, to make, execute, seal and deliver, for, and on its behalf as surety, and as its act and deed: **any and all bonds and undertakings**, and the execution of such bonds or undertakings in pursuance of these presents, shall be as binding upon said Companies, as fully and amply, to all intents and purposes, as if they had been duly executed and acknowledged by the regularly elected officers of the ZURICH AMERICAN INSURANCE COMPANY at its office in New York, New York, the regularly elected officers of the COLONIAL AMERICAN CASUALTY AND SURETY COMPANY at its office in Owings Mills, Maryland., and the regularly elected officers of the FIDELITY AND DEPOSIT COMPANY OF MARYLAND at its office in Owings Mills, Maryland., in their own proper persons.

The said Vice President does hereby certify that the extract set forth on the reverse side hereof is a true copy of Article V, Section 8, of the By-Laws of said Companies, and is now in force.

IN WITNESS WHEREOF, the said Vice-President has hereunto subscribed his/her names and affixed the Corporate Seals of the said ZURICH AMERICAN INSURANCE COMPANY, COLONIAL AMERICAN CASUALTY AND SURETY COMPANY, and FIDELITY AND DEPOSIT COMPANY OF MARYLAND, this 07th day of February, A.D. 2022.



ATTEST:  
ZURICH AMERICAN INSURANCE COMPANY  
COLONIAL AMERICAN CASUALTY AND SURETY COMPANY  
FIDELITY AND DEPOSIT COMPANY OF MARYLAND

By: *Robert D. Murray*  
Vice President

By: *Dawn E. Brown*  
Secretary

State of Maryland  
County of Baltimore

On this 07th day of February, A.D. 2022, before the subscriber, a Notary Public of the State of Maryland, duly commissioned and qualified, **Robert D. Murray, Vice President and Dawn E. Brown, Secretary** of the Companies, to me personally known to be the individuals and officers described in and who executed the preceding instrument, and acknowledged the execution of same, and being by me duly sworn, depose and say, that he/she is the said officer of the Company aforesaid, and that the seals affixed to the preceding instrument are the Corporate Seals of said Companies, and that the said Corporate Seals and the signature as such officer were duly affixed and subscribed to the said instrument by the authority and direction of the said Corporations.

IN TESTIMONY WHEREOF, I have hereunto set my hand and affixed my Official Seal the day and year first above written.



Constance A. Dunn, Notary Public  
My Commission Expires: July 9, 2023

Authenticity of this bond can be confirmed at [bondvalidator.zurichna.com](http://bondvalidator.zurichna.com) or 410-559-8790

**EXTRACT FROM BY-LAWS OF THE COMPANIES**

"Article V, Section 8, Attorneys-in-Fact. The Chief Executive Officer, the President, or any Executive Vice President or Vice President may, by written instrument under the attested corporate seal, appoint attorneys-in-fact with authority to execute bonds, policies, recognizances, stipulations, undertakings, or other like instruments on behalf of the Company, and may authorize any officer or any such attorney-in-fact to affix the corporate seal thereto; and may with or without cause modify or revoke any such appointment or authority at any time."

**CERTIFICATE**

I, the undersigned, Vice President of the ZURICH AMERICAN INSURANCE COMPANY, the COLONIAL AMERICAN CASUALTY AND SURETY COMPANY, and the FIDELITY AND DEPOSIT COMPANY OF MARYLAND, do hereby certify that the foregoing Power of Attorney is still in full force and effect on the date of this certificate; and I do further certify that Article V, Section 8, of the By-Laws of the Companies is still in force.

This Power of Attorney and Certificate may be signed by facsimile under and by authority of the following resolution of the Board of Directors of the ZURICH AMERICAN INSURANCE COMPANY at a meeting duly called and held on the 15th day of December 1998.

RESOLVED: "That the signature of the President or a Vice President and the attesting signature of a Secretary or an Assistant Secretary and the Seal of the Company may be affixed by facsimile on any Power of Attorney. Any such Power or any certificate thereof bearing such facsimile signature and seal shall be valid and binding on the Company."

This Power of Attorney and Certificate may be signed by facsimile under and by authority of the following resolution of the Board of Directors of the COLONIAL AMERICAN CASUALTY AND SURETY COMPANY at a meeting duly called and held on the 5th day of May, 1994, and the following resolution of the Board of Directors of the FIDELITY AND DEPOSIT COMPANY OF MARYLAND at a meeting duly called and held on the 10th day of May, 1996.

RESOLVED: "That the facsimile or mechanically reproduced seal of the company and facsimile or mechanically reproduced signature of any Vice-President, Secretary, or Assistant Secretary of the Company, whether made heretofore or hereafter, wherever appearing upon a certified copy of any power of attorney issued by the Company, shall be valid and binding upon the Company with the same force and effect as though manually affixed.

IN TESTIMONY WHEREOF, I have hereunto subscribed my name and affixed the corporate seals of the said Companies, this \_\_\_\_\_ day of \_\_\_\_\_,

**JAN 25 2023**



*MJ Pethick*  
 By: Mary Jean Pethick  
 Vice President

**TO REPORT A CLAIM WITH REGARD TO A SURETY BOND, PLEASE SUBMIT A COMPLETE DESCRIPTION OF THE CLAIM INCLUDING THE PRINCIPAL ON THE BOND, THE BOND NUMBER, AND YOUR CONTACT INFORMATION TO:**

Zurich Surety Claims  
 1299 Zurich Way  
 Schaumburg, IL 60196-1056  
 Ph: 800-626-4577

If your jurisdiction allows for electronic reporting of surety claims, please submit to:  
[reports@claims@zurichna.com](mailto:reports@claims@zurichna.com)

**Authenticity of this bond can be confirmed at [bondvalidator.zurichna.com](http://bondvalidator.zurichna.com) or 410-559-8790**



## 23300231 (PWP# CC-2023-082) Addendum 3 ACCO Engineered Systems Inc. Supplier Response

### Event Information

Number: 23300231 (PWP# CC-2023-082) Addendum 3  
Title: Juvenile Courts HVAC Replacement Project  
Type: Invitation for Bid  
Issue Date: 1/25/2023  
Deadline: 2/14/2023 11:00 AM (PT)  
Notes: **Summary:** The Juvenile Courts HVAC Replacement Project includes but is not limited to replacing the southern existing Multi-Zone HVAC Unit on the roof. The unit will be required to communicate the new BACnet communication system (will be installed under a different contract and project). The bid price shall include costs for engineering design specifications, local and state permitting, removal of existing Multi-Zone HVAC Unit, installation of new Multi-Zone HVAC Unit, configuration of piping, and all tools, equipment, materials, and labor for the full installation of the Multi-Zone HVAC Unit. Photographs of the existing HVAC which include nameplates are shown in the Attachment.

**Project # P303423202**  
**PWP# CC-2023-082**

**Engineers Estimate: \$ 290,000.00**

This is deemed a **Vertical** construction project.

**NON-Mandatory Pre-Bid Meeting: February 1, 2023 at 9:00 am** at the Juvenile Courthouse 1545 East 5th Street where bidders can inspect the existing unit and ask questions.

### Contact Information

Contact: Carol Akers, Purchasing & Contracts Administrator  
Address: Suite 2  
City Hall - Executive Office  
201 North Carson Street, Suite 2

Carson City, NV 89701  
Phone: 1 (775) 283-7362  
Fax: 1 (775) 887-2286  
Email: cakkers@carson.org

Exhibit A

**ACCO Engineered Systems Inc. Information**

Contact: Meile Young  
 Address: 2010 Kleppe Lane  
 Sparks, NV 89431  
 Phone: (775) 331-4455  
 Email: myoung@accoes.com

By submitting your response, you certify that you are authorized to represent and bind your company.

Meile Young  
 Signature

myoung@accoes.com  
 Email

Submitted at 2/14/2023 09:10:10 AM (PT)

**Supplier Note**

We have also included a separate ACCO bid proposal which includes our scope, inclusions and exclusions.

**Requested Attachments****Bid Bond Form**

Bid Bond Juvenile Courts HVAC Replacement - Signed.pdf

This document is required at time of bid submission. You can download this document from the "Attachments" Tab.

**Vendor Information Form**

Vendor Information.pdf

This document is required at time of bid submission. You can download this document from the "Attachments" Tab.

**References**

Project References.pdf

This is required at time of bid submission. Refer to Attributes for information needed.

**5% Bidders Form**

5% Bid - Signed.pdf

This document is required at time of bid submission. You can download this document from the "Attachments" Tab.

**1% Subcontractor Information**

1% Bid - Signed.pdf

Required 2 hours after bid opening. You can download this document from the "Attachments" Tab. Email to  
 CAkers@carson.org

**Certification of Auth & Understanding**

Cert of Authorization and Understanding - Signed.pdf

This document is required at time of bid submission from the General Contractor. You can download this document from the "Attachments" Tab.

**Conflict of Interest**

Conflict of Interest - Signed.pdf

This document is required at time of bid submission from the General Contractor. You can download this document from the "Attachments" Tab.

**Local Preference Affidavit**

Local Preference - Signed.pdf

This document is required at time of bid submission. You can download this document from the "Attachments" Tab.(If Applicable)

**Certificate of Eligibility (NRS 338.147 & 338.1389)** ACCO NV Cert of Eligibility (2549, 55552) Exp Aug 2023.pdf

Required Certificate from General at time of bid (If Applicable)

**Project Workforce Checklist**

Project Workforce - Signed.pdf

Required from General 24 hours after bid opening. You can download this document from the "Attachments" Tab.  
 Email to CAkers@carson.org

**ACCO - Juvenile Courts Proposal.pdf**

ACCO Bid Proposal including our inclusions and exclusions.

**Bid Attributes**

<b>1</b>	<p><b>Contractor's License</b></p> <p>Carson City has determined that the responsive bidder must possess a minimum of a <b>Class A</b> with appropriate sub-classifications or subcontractors. All Contractors license shall be in good standing and issued by the Nevada State Contractor's Board at the time of the bid.</p> <div style="border: 1px solid black; padding: 2px;">                 2549 Class C-21                  55552 Class C-1                  83321 Class B             </div>
<b>2</b>	<p><b>A Copy of Contractor's Certificate of Eligibility</b></p> <p>A copy of Contractor's Certificate of eligibility issued by the State of Nevada Contractors' Board as proof of Bidder's compliance with the provisions of N.R.S. 338.147 must be submitted with his/her bid for the preference to be considered. This Statute does not apply to projects expected to cost less than \$250,000.</p> <div style="border: 1px solid black; padding: 2px;">                 Submitted             </div>
<b>3</b>	<p><b>Substitutions</b></p> <p>No substitution or revision to this Bid Proposal form will be accepted. Carson City will reject any Bid that is received that has changes or alterations to this document.</p> <div style="border: 1px solid black; padding: 2px;">                 Acknowledged             </div>
<b>4</b>	<p><b>Acknowledgement of Addendums</b></p> <p>Bidder acknowledges receipt of _____ Addendums.</p> <div style="border: 1px solid black; padding: 2px;">                 3 Addendums acknowledged             </div>
<b>5</b>	<p><b>References:</b></p> <p>Submit <b>(In Response Attachments)</b> at least (3) contracts of a similar nature performed by your firm in the last (3) years. If NONE, use your Company's letterhead (and submit with your bid proposal) to list what your qualifications are for this contract. Carson City reserves the right to contact and verify, with any and all references listed, the quality of and the degree of satisfaction for such performance.</p> <p><b>Information to be included:</b></p> <ol style="list-style-type: none"> <li>1. Company Name</li> <li>2. Mailing Address</li> <li>2. Telephone Number</li> <li>4. E-Mail</li> <li>5. Project Title</li> <li>6. Amount of Contract</li> <li>7. Scope of Work</li> </ol> <div style="border: 1px solid black; padding: 2px;">                 List attached of (3) references on ACCO letterhead.             </div>
<b>6</b>	<p><b>Prevailing Wages</b></p> <p>The successful bidder will be required to provide the current Prevailing Wages used in preparation of their bid within 24 hours of bid submission. The bidder is responsible to verify with the Labor Commissioner if any addendums have been issued. <b>(Email to Cakers@carson.org)</b></p> <div style="border: 1px solid black; padding: 2px;">                 Acknowledged             </div>

## 7 Required Documents

Exhibit A

### Acknowledgement of Required Documents:

**Bid Bond**-Due at Bid Submission

**Vendor Information**-Due at Bid Submission

**References**-Due at Bid Submission

**5%-Sub-Contractor Information**-Due at Bid Submission. **General Contractor must self-list.**

**1%-Sub-Contractor Information**-Due by the (3) three lowest bidders (2) two hours after bid opening **General Contractor must self-list.(Email to Cakers@carson.org)**

**Cert of Authorization & Understanding**-Due from General at Bid Submission/Sub-Contractors first week of work

**Conflict of Interest**-Due from General at Bid Submission/Sub-Contractors first week of work

**Local Preference Affidavit**-Due at time of Bid Submission (If applicable)

**Certificate of Eligibility**-(NRS 338.14 & 338.1389-Due from General at Bid Submission (If applicable)

**Project Workforce Checklist**-Due from Lowest Bid-General Contractor 24 hours from bid opening (**Email to Cakers@carson.org**)

**Prevailing Wage Determination(State)**-Due from General Contractor 24 hours after bid opening (**Email to Cakers@carson.org**)

**Sub Contractor Monthly Payment Form**-Due with each pay application submitted

Acknowledged

## 8 Apprentices-NRS 338.01165 (SB 207)

### Apprentices-NRS 338.01165; SB 207 (2019)

As of January 1, 2020, NRS 338.01165 requires all contractors employing workers on certain public works projects to utilize apprentices for portions of the work. One or more apprentices must be used for at least 10% of the total hours on vertical construction and 3% of the total hours for horizontal construction. These percentages apply to the total hours of labor worked for each apprenticed craft or type of work to be performed on the public work for which more than three workers are employed. Under NRS Chapter 338, this project is a public work that requires the use of apprentices. All contractors must comply with NRS 338.01165 for this project, unless a modification, waiver, or exemption applies.

The Nevada Labor Commissioner has prepared forms for use in complying with the apprenticeship requirements. The following forms are available on the Labor Commissioner's website at: [http://labor.nv.gov/Apprenticeship\\_Utilization\\_Act/Apprenticeship\\_Utilization\\_Act/](http://labor.nv.gov/Apprenticeship_Utilization_Act/Apprenticeship_Utilization_Act/)

- **Apprenticeship Utilization Request Form**  
Titled "Request For Apprentice Availability On A Public Work"
- **Apprenticeship Utilization Waiver Request Form**  
Titled: "Apprenticeship Utilization Act Waiver Request"
- **Apprenticeship Agreement Form**  
Titled: "Apprentice Agreement"



Titled: "Project Workforce Checklist"

**NO APPRENTICESHIP DOCUMENTS ARE REQUIRED TO BE SUBMITTED WITH A CONTRACTOR'S BID SUBMISSION.**

**After the bids are opened, the apparent successful bidder must provide the Project Workforce Checklist to the City within 24 hours after bid opening** along with the subcontractor list, that indicates expected classification of workers on the project and the determination as to whether or not apprentices may be required. A PROJECT WORKFORCE CHECKLIST MUST BE COMPLETED BY THE CONTRACTOR. **(Emailed to Cakers@carson.org.)**

Sub-Contractors Project Workforce Checklist will be required prior to beginning work.

After the bid is awarded a pre-construction meeting will be held to set up the construction schedule. When working dates are known and if apprentices are required by NRS 338.01165, the Apprenticeship Utilization Request Form should be submitted to the necessary Registered Apprenticeship Programs to request apprentices for the project.

Waiver requests may be submitted to the City at any time, due to NRS 338.01165(10)(d) (1) (no apprentices available from apprenticeship programs within Carson City's jurisdiction) (2) (required to perform uniquely complex or hazardous tasks on the public work that require the skill and expertise of a greater percentage of the journeymen) or (3) (apprentices requested from an apprenticeship program have been denied or not approved within 5 business days). The waiver requests should be submitted to the City as soon as the need for a waiver is known. Along with the waiver request, the contractor and any subcontractors must provide to the City all required documentation to support the waiver request.

Upon receipt of any waiver requests, the City will forward the materials to the Nevada Labor Commissioner for consideration and possible approval. Upon receipt of that determination, the City will communicate the results back to the Contractor as soon as possible.

**IF NO WAIVER OR MODIFICATION IS OBTAINED, THE CONTRACTOR IS RESPONSIBLE FOR COMPLYING WITH THE APPRENTICESHIP REQUIREMENTS OF NRS 338.01165.**

Acknowledged

**9 Acknowledgement & Execution of Bid Proposal**

I the Bidder, do depose and say: That I am the Bidder or authorized agent of the Bidder; and that I have read and agree to abide by this Bid which includes, but is not limited to the following documents: Instructions to Bidders, Bid Bond, Proposal Summary, Contract Award Instructions and Information, Sample Contract, Sample Performance Bond, Sample Labor and Material Payment Bond, General Conditions, Special Conditions, Standard Specifications, Technical Specifications, Geotechnical Report (if any), Contract Drawings, Permits (if any), and any addenda issued and understands the terms, conditions, and requirements thereof; that if his/her bid is accepted that he/she agrees to furnish and deliver all materials except those specified to be furnished by the City (Owner) and to do and perform all work for said project, together with incidental items necessary to complete the work to be constructed in accordance with the Contract Documents, Contract Drawings, and Specifications annexed hereto.

Acknowledged (Acknowledged )

**Bid Lines**

**1 Package Header**

Schedule A: Base Bid Items

Quantity:   1   UOM:  EA  Total: \$288,867.00



**Package Items**

Exhibit A

1.1 Design, Permitting, Removal and Replacement of Juvenile Courthouse Multi-Zone HVAC Unit

Quantity:   1   UOM:   LS   Unit Price:  Total:

**Response Total: \$288,867.00**

## Vendor Information

<b>Vendor Information:</b>	
Company Name: ACCO Engineered Systems, Inc.	Federal ID No: 95-1625123
Mailing Address: 888 E Walnut Street	City, State, Zip Code: Pasadena, CA 91101
Telephone Number: 775-331-4455	Email:

<b>Contact Person/Title:</b>	
Name: Ben Lillig	Title: Project Manager
Mailing Address: 2010 Kleppe Lane	City, State, Zip Code: Sparks, NV 89431
Telephone Number: 775-277-1802	Email: blillig@accoes.com

<b>Licensing Information:</b>	
Nevada State Contractor's License Number: 2549, 55552, 83321	
License Classification(s): C-21, C-1, B	Date Issued: 8/22/1950, 8/14/2003, 3/23/2018
Limitation(s) of License: Unlimited	Date of Expiration: 8/31/2024, 8/31/2024, 3/31/2024
Name of Licensee: ACCO Engineered Systems, Inc.	
<b>Carson City Business License Number: BL-006367-2021</b>	
Name of Licensee: ACCO Engineered Systems, Inc.	

<b>Disclosures of Principals: Corporation (see attached for list of company Officers)</b>		
<b>Individual and/or Partnership: N/A</b>		
<b>(1) Owner Name: N/A</b>		
Address:		
City:	State:	Zip Code:
Telephone:	Email:	
<b>(2) Owner Name: N/A</b>		
Address:		
City:	State:	Zip Code:
Telephone:	Email:	
<b>(1) Other Title: N/A</b>		
Name:		
<b>(2) Other Title: N/A</b>		
Name:		

# 2023 Officers

ACCO ENGINEERED SYSTEMS, INC.

## CORPORATE OFFICERS

### **JEFFREY R. MARRS**

President and Chief Executive Officer

### **JOHN G. PETERSEN**

Chief Financial Officer and Treasurer

### **ROBERT M. OSIER**

Corporate Secretary and General Counsel

## ADDITIONAL OFFICERS

**CHARLES J. DARWAY**, Executive Vice President, Corporate Operations

**CHRISTOPHER B. LEU**, Chief Information Officer

**DAVID E. ANDERSON**, Senior Vice President, Construction

**CURTIS J. CADY**, Senior Vice President, Corporate Operations, Responsible Managing Officer – Contractor's License

**RONALD A. FALASCA**, Senior Vice President, Construction

**KEVIN P. FITZGERALD**, Senior Vice President, Construction

**PETER J. FORTIN**, Senior Vice President, Labor Relations

**GREGORY M. HOLBROOK**, Senior Vice President, Construction

**MICHAEL J. POTTS**, Senior Vice President, Facility Service

**THOMAS E. REYNOLDS**, Senior Vice President, Facility Service

**TAREQ M. BARAKZOY**, Vice President, Geo. H. Wilson Mechanical Contractors

**JONATHAN B. BELL**, Vice President, Construction

**MARK D. DAUW**, Vice President, Finance

**ROBERT A. FELIX**, Vice President, Construction, Responsible Managing Officer – Contractor's License

**RICHARD J. FERREIRA**, Vice President, Facility Service

**BRYAN P. GRAHAM**, Vice President, Engineering, Responsible Managing Officer – Contractor's License

**DARLENE J. MITCHELL**, Vice President, Information Technology

**CHARLES J. OBEROSLER**, Vice President, Construction

**RICK R. RILEY**, Vice President, Construction Operations

**PATRICK A. ROCHON**, Vice President, Facility Service

**DONOVAN S. SEEBER**, Vice President, Safety

**CHRISTOPHER F. WAY**, Vice President, Procurement

**ANTHONY A. RUBALCAVA**, Responsible Managing Officer – Civil-Structural Engineering Business Registration

**RICHARD J. WILSON**, Responsible Managing Officer – Contractor's License

**NATALIE ABDOU**, Assistant Secretary

**JOHN C. EBERSBERGER**, Assistant Secretary

**ADAM S. FOGEL**, Assistant Secretary

**JODI L. DREWERY**, Assistant Secretary

**HELEN E. LEONARD**, Assistant Secretary

**DAVID B. OSBURN**, Assistant Secretary

**HUGH D. PALMER**, Assistant Secretary

**CARLTON A. SEYFORTH**, Assistant Secretary

**SCOTT B. ELLIS**, Assistant Secretary



January 31, 2023

**Subject: Parent Organization, Officer Affiliations and Previous Affiliations**

ACCO Engineered Systems, Inc. DBA ACCO Engineered Systems (ACCO) is the parent corporation of the following wholly owned subsidiaries performing construction-related work:

- Sunbelt Controls, Inc.
- Sunbelt Electrical Company, Inc. dba Sunbelt Electric
- AES Industrial, Inc.
- ACCO-Wilson, Inc.
- Smith Mechanical-Electrical-Plumbing
- Pipe Line Specialties, Inc.

ACCO performs construction-related work under a separate California contractor's license under the DBA *Geo H. Wilson Mechanical Contractors*.

In the past five years and before joining ACCO, the ACCO officers listed below had operated a construction firm under another name:

- Richard J. Wilson, Responsible Managing Officer, ACCO Engineered Systems, was previously an officer of Geo. H. Wilson, Inc. from 1996-2018. ACCO Engineered Systems acquired certain assets of Geo. H. Wilson, Inc. in May 2018.

ACCO Officers who also serve as Officers for ACCO wholly owned subsidiaries currently performing construction-related work are as follows:

ACCO Engineered Systems, Inc.	Sunbelt Controls, Inc.	Sunbelt Electrical Company, Inc.	AES Industrial, Inc.	ACCO-Wilson, Inc.	Smith Mechanical-Electrical-Plumbing	Pipe Line Specialties, Inc.
<b>John G. Petersen</b> Chief Financial Officer (CFO)		CFO		CFO		
<b>Robert M. Osier</b> Secretary	Assistant Secretary	Secretary		Secretary		
<b>Ronald A. Falasca</b> Senior Vice President		President				
<b>Tareq M. Barakzoy</b> Vice President				President		
<b>Mark D. Dauw</b> Vice President			Treasurer (CFO)			
<b>Kevin P. FitzGerald</b> Senior Vice President			President			
<b>Carlton Seyforth</b> Assistant Secretary	Assistant Secretary					
<b>Helen Leonard</b> Assistant Secretary	Assistant Secretary	Assistant Secretary	Assistant Secretary		Assistant Secretary	
<b>Hugh Palmer</b> Assistant Secretary	Assistant Secretary	Assistant Secretary	Assistant Secretary		Assistant Secretary	

DocuSigned by:

*Robert M. Osier*

Robert M. Osier  
Corporate Secretary

Bid #23300231 (PWP#CC-2023-082)  
Juvenile Courts HVAC Replacement Project  
Bid Date: 2/15/2023/11:00am  
ACCO Engineered Systems, Inc.  
Page 1 of 2

## REFERENCES

Company Name: Caron City Purchasing  
Mailing Address: 201 North Carson St., Suite 2, Carson City, NV 89701  
Telephone Number: 775-283-7362  
E-Mail: cakars@carson.org  
Project Title: Carson City Library Multizone (Project #P303422210)  
Amount of Contract: \$203,496  
Scope of Work:

- Engineered mechanical plans in CAD & PDF format for permit
- Acquire permits and pay permit fees
- Demolish and remove one (1) existing Lennox multizone unit
- Furnish and install one (1) replacement multizone unit
- Provide electrical disconnect and reconnect
- Provide gas piping disconnect and reconnect
- Furnish and install Alerton DDC controls for the new unit including new space temperature sensors and control wire
- Provide all condensate piping for the new unit including condensate neutralizers
- Furnish necessary cranes, rigging, and trucking for our scope of work
- Equipment check, test and start up by ACCO technicians
- Provide certified and independent test and balance of the new system
  - Includes pre-read of the existing system
- One-year warranty on all ACCO supplied materials and labor

Company Name: Hamilton Company  
Mailing Address: 4970 Energy Way, Reno, NV 89502  
Telephone Number: 775-648-3000 ext. 645  
E-Mail: dan.tuttle@hamiltoncompany.com  
Project Title: Hamilton B1 Multizone  
Amount of Contract: \$149,950

### Scope of Work:

- ❖ Remove and dispose of one (1) Carrier Ten Zone Multizone Unit
- ❖ Furnish and install one (1) Multizone Unit
  - The current zoning plan and controls are to remain the same
- ❖ Provide the disconnect and reconnect of electrical power wiring and gas piping
- ❖ Provide plumbing for the new unit's condensate drain
- ❖ Provide certified and independent Test and Balance for the new system
- ❖ Provide start-up of the new equipment by a factory authorized technician
- ❖ Provide all cranes and rigging for the scope of work above

Bid #23300231 (PWP#CC-2023-082)  
Juvenile Courts HVAC Replacement Project  
Bid Date: 2/15/2023/11:00am  
ACCO Engineered Systems, Inc.  
Page 2 of 2

Company Name: Hamilton Company  
Mailing Address: 4970 Energy Way, Reno, NV 89502  
Telephone Number: 775-648-3000 ext. 645  
E-Mail: dan.tuttle@hamiltoncompany.com  
Project Title: Hamilton B3 Multizone  
Amount of Contract: \$169,039

**Scope of Work:**

- ❖ Remove and dispose of one (1) Mammoth Twelve Zone Multizone Unit
- ❖ Furnish and install one (1) Multizone Unit
  - The current zoning plan is to remain the same
  - New controls are required for this unit
- ❖ Provide the disconnect and reconnect of electrical power wiring and gas piping
- ❖ Provide plumbing for the new unit's condensate drain
- ❖ Provide certified and independent Test and Balance for the new system
- ❖ Provide start-up of the new equipment by a factory authorized technician
- ❖ Provide all cranes and rigging for the scope of work above

**BIDDER SUBCONTRACTOR INFORMATION**  
 (For subcontractors exceeding five percent (5%) of the bid amount)

Contract No.: CC-2023-082

Contractor: ACCO Engineered Systems, Inc.

Project No(s): P303423202

Address: 2010 Kleppe Lane

Total Bid Amount \$ 288,867.00

Sparks, NV 89431

This information must be submitted with your bid proposal. The bidder shall enter "NONE" under "SUBCONTRACTOR NAME" if not using subcontractors exceeding 5% of the bid amount. Per NRS 338.141 Prime Contractor to list itself on Subcontractor's list if to perform any of the work.

SUBCONTRACTOR NAME AND ADDRESS AND UEI NUMBER (If Federal Funds Apply)	PHONE NO.	BID LINE ITEM NO(S).*	NEVADA CONTRACTOR LICENSE # (IF APPLICABLE)	LICENSE LIMIT (IF APPLICABLE)	DESCRIPTION OF WORK OR SERVICES TO BE SUBCONTRACTED
ACCO Engineered Systems, Inc. 2010 Kleppe Lane, Sparks, NV 89431	775-331-4455	1.1	2549, 55552, 83321	unlimited	HVAC
Triumph Electric, 1360 Greg St, #106, Sparks, NV 89431	775-355-1965	1.1	0067820	unlimited	Electrical

*The undersigned affirms all work, other than that being performed by the subcontractors listed in the subcontractor reports submitted for this contract, will be performed by the Prime Contractor listed above.*

\* Please list all items (attach a separate sheet if necessary). Do not enter "multiple" or "various."

  
 \_\_\_\_\_  
 Contractor's Signature

\_\_\_\_\_  
 Date

Telephone No. 775-331-4455



**BIDDER SUBCONTRACTOR INFORMATION**

(For subcontractors exceeding one percent (1%) of bid amount or \$50,000, whichever is greater)

Contract No.: CC-2023-082

Contractor: ACCO Engineered Systems, Inc.

Project No(s): P303423202

Address: 2010 Kleppe Lane

Sparks, NV 89431

Bid Amount \$ 288,867.00

This information must be submitted by the three (3) lowest bidders no later than 2 hours after the bid opening time. The bidder shall enter "NONE" under "SUBCONTRACTOR NAME" if not using subcontractors exceeding 1% of the bid amount. Per NRS 338.141 Prime Contractor to list itself on Subcontractor's list if to perform any of the work.

SUBCONTRACTOR NAME AND ADDRESS AND UEI NUMBER (If Federal Funds Apply)	SUBCONTRACTOR PHONE NO.	BID LINE ITEM NO(S).*	NEVADA CONTRACTOR LICENSE # (IF APPLICABLE)	LICENSE LIMIT (IF APPLICABLE)	DESCRIPTION OF WORK OR SERVICES TO BE SUBCONTRACTED
ACCO Engineered Systems, Inc. 2010 Kleppe Lane, Sparks, NV 89431	775-331-4455	1.1	2549, 55552, 83321	unlimited	HVAC
Triumph Electric, 1360 Greg St, #106, Sparks, NV 89431	775-355-1965	1.1	0067820	unlimited	Electrical
Raglen System Balance, 898 Maestro Dr, #100, Reno, NV 89511	775-747-0100	1.1	N/A	N/A	Test & Balance
Bragg Crane, 2251 Larkin Cir, Sparks, NV 89431	775-359-2900	1.1	0031903	unlimited	Hoisting

\* Please list all items (attach a separate sheet if necessary). Do not enter "multiple" or "various."

  
Contractor's Signature

2/14/2023

Date

Telephone No. 775-331-4455

## Local Preference Affidavit (This form is required to receive a preference in bidding)

I, Ryan Novacek, on behalf of the Contractor, ACCO Engineered Systems, Inc., swear and affirm that in order to be in compliance with NRS 338.147 and NRS 338.1389 and be eligible to receive a preference in bidding on:

Bid No. 23300231

Project Name: Juvenile Courts HVAC Replacement Project

certify that the following requirement will be adhered to, documented, and attained on completion of the contract. Upon submission of this affidavit on behalf of

I recognize and accept that failure to comply with any requirements is a material breach of the contract and entitles the City to damages. In addition, the Contractor may lose their preference designation and/or lose their ability to bid on public works for one year, pursuant to NRS 338.147 and NRS 338.1389:

1. The Contractor shall ensure that 50 percent of the workers employed on the job possess a Nevada driver's license or identification card;
2. The Contractor shall ensure all vehicles used primarily for the public work will be registered and (where applicable) partially apportioned to Nevada;
3. The Contractor shall ensure at least 50 percent of the design professionals who work on the project (including sub-contractors) have a Nevada driver's license or identification card.
4. The Contractor shall ensure payroll records related to this project are maintained and available within the State of Nevada.

**\*Note that specific sections of NRS 338 detailing the continued procedures associated with the use of the "bidder's preference" have been amended by the passage of Assembly Bill 172 effective 7/1/13, requiring this affidavit and subsequent record keeping and reporting by the General Contractor using the preference program and awarded this project. These requirements are not applicable to Contractors who do not use the "Bidder's Preference" eligibility certificate in their bid.**

By: Ryan Novacek

Title: Sales Manager

Signature: 

Date: 2/14/2023

**NEVADA STATE CONTRACTORS BOARD**

5390 KIETZKE LANE, SUITE 102, RENO, NEVADA, 89511 (775) 688-1141 FAX (775) 688-1271  
8400 WEST SUNSET ROAD, SUITE 150, LAS VEGAS, NEVADA, 89113, (702) 486-1100 FAX (702) 486-1190

**SPECIALTY CONTRACTOR'S RESTRICTED**  
**CERTIFICATE OF ELIGIBILITY**  
**PER NRS 338.147 and NRS 338.1389**

CERTIFICATE NUMBER: **SBPC-19-04-01-0276**

**ACCO ENGINEERED SYSTEMS INC** (HEREIN THE "CONTRACTOR") NEVADA STATE CONTRACTORS' LICENSE NUMBER: **0055552** ORIGINAL ISSUE DATE: **08/14/2003** BUSINESS TYPE: **CORPORATION** CLASSIFICATION: **C-1 PLUMBING & HEATING** MONETARY LICENSE LIMIT: **UNLIMITED** STATUS: **ACTIVE**, IS HEREBY ISSUED THIS CERTIFICATE BY THE NEVADA STATE CONTRACTORS' BOARD, BASED UPON THE INFORMATION CONTAINED IN THE STATEMENT OF COMPLIANCE WITH NEVADA REVISED STATUTES (NRS) 338.147 AND NRS 338.1389 AND THE AFFIDAVIT OF CERTIFIED PUBLIC ACCOUNTANT SUBMITTED TO THE NEVADA STATE CONTRACTORS BOARD AS PROOF OF CONTRACTOR'S COMPLIANCE WITH THE PROVISIONS OF NRS 338.147 AND NRS 338.1389. IN ACCORDANCE WITH THE PROVISIONS OF NRS 338.147(3), THE ABOVE-NAMED CONTRACTOR AND A CERTIFIED PUBLIC ACCOUNTANT HAVE SUBMITTED FULLY EXECUTED AND NOTARIZED SWORN AFFIDAVITS AS PROOF OF PREFERENTIAL BIDDER STATUS, UNDER PENALTY OF PERJURY, CERTIFYING THAT THE CONTRACTOR IS QUALIFIED TO RECEIVE A PREFERENCE IN BIDDING AS SET FORTH IN NRS 338.147 AND NRS 338.1389 AND OTHER MATTERS RELATING THERETO WHEN ACTING AS A PRIME CONTRACTOR ON THE SPECIFIC PUBLIC WORKS PROJECT FOR WHICH THIS CERTIFICATE IS SUBMITTED BY THE CONTRACTOR.

THIS CERTIFICATE OF ELIGIBILITY IS ISSUED ON **SEPTEMBER 1, 2022** AND EXPIRES ON **AUGUST 31, 2023**, UNLESS SOONER REVOKED OR SUSPENDED BY THE NEVADA STATE CONTRACTORS BOARD.

  
NANCY MATHIAS, LICENSING ADMINISTRATOR      DATE **8/14/2022**  
FOR MARGI GREIN, EXECUTIVE OFFICER



The Nevada State Contractors Board assumes no liability or responsibility for the accuracy or validity of the information contained in the Contractors Statement of Compliance or the Affidavit of Certified Public Accountant as Proof of Contractors Compliance with the Provisions of NRS 338.147 and NRS 338.1389. The above-named Contractor shall bear the responsibility to ascertain the accuracy and validity of the affidavits provided to support the issuance of this certificate.





## NEVADA STATE CONTRACTORS BOARD

5390 KIETZKE LANE, SUITE 102, RENO, NEVADA, 89511 (775) 688-1141 FAX (775) 688-1271  
8400 WEST SUNSET ROAD, SUITE 150, LAS VEGAS, NEVADA, 89113, (702) 486-1100 FAX (702) 486-1190

### **SPECIALTY CONTRACTOR'S RESTRICTED** **CERTIFICATE OF ELIGIBILITY** **PER NRS 338.147 and NRS 338.1389**

CERTIFICATE NUMBER: **SBPC-15-07-16-0214**

**ACCO ENGINEERED SYSTEMS INC** (HEREIN THE "CONTRACTOR") NEVADA STATE CONTRACTORS' LICENSE NUMBER: **0002549** ORIGINAL ISSUE DATE: **08/22/1950** BUSINESS TYPE: **CORPORATION** CLASSIFICATION: **C21-REFRIGERATION & AIR CONDITIONING** MONETARY LICENSE LIMIT: **UNLIMITED** STATUS: **ACTIVE**, IS HEREBY ISSUED THIS CERTIFICATE BY THE NEVADA STATE CONTRACTORS' BOARD, BASED UPON THE INFORMATION CONTAINED IN THE STATEMENT OF COMPLIANCE WITH NEVADA REVISED STATUTES (NRS) 338.147 AND NRS 338.1389 AND THE AFFIDAVIT OF CERTIFIED PUBLIC ACCOUNTANT SUBMITTED TO THE NEVADA STATE CONTRACTORS BOARD AS PROOF OF CONTRACTOR'S COMPLIANCE WITH THE PROVISIONS OF NRS 338.147 AND NRS 338.1389. IN ACCORDANCE WITH THE PROVISIONS OF NRS 338.147(3), THE ABOVE-NAMED CONTRACTOR AND A CERTIFIED PUBLIC ACCOUNTANT HAVE SUBMITTED FULLY EXECUTED AND NOTARIZED SWORN AFFIDAVITS AS PROOF OF PREFERENTIAL BIDDER STATUS, UNDER PENALTY OF PERJURY, CERTIFYING THAT THE CONTRACTOR IS QUALIFIED TO RECEIVE A PREFERENCE IN BIDDING AS SET FORTH IN NRS 338.147 AND NRS 338.1389 AND OTHER MATTERS RELATING THERETO WHEN ACTING AS A PRIME CONTRACTOR ON THE SPECIFIC PUBLIC WORKS PROJECT FOR WHICH THIS CERTIFICATE IS SUBMITTED BY THE CONTRACTOR.

THIS CERTIFICATE OF ELIGIBILITY IS ISSUED ON **SEPTEMBER 1, 2022** AND EXPIRES ON **AUGUST 31, 2023**, UNLESS SOONER REVOKED OR SUSPENDED BY THE NEVADA STATE CONTRACTORS BOARD.

*Nancy Mathias*

*8/4/2022*

NANCY MATHIAS, LICENSING ADMINISTRATOR      DATE  
FOR MARGI GREIN, EXECUTIVE OFFICER



The Nevada State Contractors Board assumes no liability or responsibility for the accuracy or validity of the information contained in the Contractors Statement of Compliance or the Affidavit of Certified Public Accountant as Proof of Contractors Compliance with the Provisions of NRS 338.147 and NRS 338.1389. The above-named Contractor shall bear the responsibility to ascertain the accuracy and validity of the affidavits provided to support the issuance of this certificate.

### Certification of Authorization and Understanding

Project Name: Juvenile Courts HVAC Replacement

Project Number: P303423202

This is to certify that the principals, and the authorized payroll officer certify the following person(s) is designated as the payroll officer for the undersigned and is authorized to sign the Statement of Compliance which will accompany each weekly certified payroll report for this project.

Jennifer Atkins

Payroll Officer (Name)

Jennifer Atkins

Payroll Officer (Signature)

ACCO Engineered Systems, Inc.

(Name of Contractor/Subcontractor)

By 

(Owner's Signature)

Sales Manager

(Title)

2549, 55552, 83321

(Contractor/Subcontractor License Number)

2/14/2023

(Date)

**Conflict of Interest Disclosure Form**

Date: 2/14/2023

Project: P303423202

Title: Juvenile Courts HVAC Replacement Project

Name: Ryan Novacek

Position: Sales Manager

Please describe below any relationships, transactions, positions you hold (volunteer or otherwise), or circumstances that you believe could contribute to a conflict of interest:

I have no conflict of interest to report.

I have the following conflict of interest to report (please specify other nonprofit and for-profit boards you (and your spouse) sit on, any for-profit businesses for which you or an immediate family member are an officer or director, or a majority shareholder, and the name of your employer and any businesses you or a family member own:

I hereby certify that the information set forth above is true and complete to the best of my knowledge.

Signature:



Date: 2/14/2023



OFFICE OF THE LABOR COMMISSIONER  
 1818 COLLEGE PARKWAY, SUITE 102  
 CARSON CITY, NEVADA 89706  
 PHONE (775) 684-1890  
 FAX (775) 687-6409  
 E-Mail: [mail1@labor.nv.gov](mailto:mail1@labor.nv.gov)

STATE OF NEVADA  
 Office of the Labor Commissioner

Exhibit A  
 3300 W. SAHARA AVE. SUITE 225  
 LAS VEGAS, NEVADA 89102  
 PHONE (702) 486-2650  
 FAX (702) 486-2660  
 E-Mail: [publicworks@labor.nv.gov](mailto:publicworks@labor.nv.gov)

**Project Workforce Checklist**

Contract No.: CC-2023-0 Project Name: Juvenile Courts HVAC Replacement Project  
**USE MOST CURRENT EXAMPLE ON LABOR COMMISSIONERS WEBSITE**  
 Contractor/Subcontractor: ACCO Engineered Systems, Inc.

Craft/Trade	More than 3 Employees Anticipated?			Anticipate Needing Waiver?	
	Yes	No	N/A	Yes	No
<b>Air Balance Technician</b>	Yes <input type="checkbox"/>	No <input checked="" type="checkbox"/>	N/A <input type="checkbox"/>	Yes <input type="checkbox"/>	No <input checked="" type="checkbox"/>
<b>Alarm Installer</b>	Yes <input type="checkbox"/>	No <input type="checkbox"/>	N/A <input checked="" type="checkbox"/>	Yes <input type="checkbox"/>	No <input type="checkbox"/>
<b>Asbestos Abatement (See Laborers)</b>	Yes <input type="checkbox"/>	No <input type="checkbox"/>	N/A <input checked="" type="checkbox"/>	Yes <input type="checkbox"/>	No <input type="checkbox"/>
<b>Bricklayer</b> , can also include tile setter, terrazzo workers and marble masons.	Yes <input type="checkbox"/>	No <input type="checkbox"/>	N/A <input checked="" type="checkbox"/>	Yes <input type="checkbox"/>	No <input type="checkbox"/>
<b>Carpenter</b> , can also include cement masons, floor coverer, millwright and piledriver (non-equipment), plasterers and terrazzo workers.	Yes <input type="checkbox"/>	No <input type="checkbox"/>	N/A <input checked="" type="checkbox"/>	Yes <input type="checkbox"/>	No <input type="checkbox"/>
<b>Cement Mason</b> , can also include plasterers.	Yes <input type="checkbox"/>	No <input type="checkbox"/>	N/A <input checked="" type="checkbox"/>	Yes <input type="checkbox"/>	No <input type="checkbox"/>
<b>Electrician</b> , includes communication technician, line, neon sign and wireman. Can also include alarm installer.	Yes <input type="checkbox"/>	No <input checked="" type="checkbox"/>	N/A <input type="checkbox"/>	Yes <input type="checkbox"/>	No <input checked="" type="checkbox"/>
<b>Elevator Constructor</b>	Yes <input type="checkbox"/>	No <input type="checkbox"/>	N/A <input checked="" type="checkbox"/>	Yes <input type="checkbox"/>	No <input type="checkbox"/>
<b>Fence Erector (See Laborers)</b> non-steel/iron. (See Iron Workers) steel/iron.	Yes <input type="checkbox"/>	No <input type="checkbox"/>	N/A <input checked="" type="checkbox"/>	Yes <input type="checkbox"/>	No <input type="checkbox"/>
<b>Flag Person (See Laborers)</b>	Yes <input type="checkbox"/>	No <input type="checkbox"/>	N/A <input checked="" type="checkbox"/>	Yes <input type="checkbox"/>	No <input type="checkbox"/>
<b>Floor Coverer</b>	Yes <input type="checkbox"/>	No <input type="checkbox"/>	N/A <input checked="" type="checkbox"/>	Yes <input type="checkbox"/>	No <input type="checkbox"/>
<b>Glazier</b> (see also Painters and Allied Trades)	Yes <input type="checkbox"/>	No <input type="checkbox"/>	N/A <input checked="" type="checkbox"/>	Yes <input type="checkbox"/>	No <input type="checkbox"/>
<b>Highway Striper (See Laborers)</b>	Yes <input type="checkbox"/>	No <input type="checkbox"/>	N/A <input checked="" type="checkbox"/>	Yes <input type="checkbox"/>	No <input type="checkbox"/>
<b>Hod Carrier (See Laborers)</b> , includes brick-mason tender and plaster tender.	Yes <input type="checkbox"/>	No <input type="checkbox"/>	N/A <input checked="" type="checkbox"/>	Yes <input type="checkbox"/>	No <input type="checkbox"/>
<b>Iron Worker</b> , can also include fence erectors (steel/iron).	Yes <input type="checkbox"/>	No <input type="checkbox"/>	N/A <input checked="" type="checkbox"/>	Yes <input type="checkbox"/>	No <input type="checkbox"/>
<b>Laborer</b> , can also include cement mason and does include asbestos abatement, hod carrier brick mason tender, hod carrier plaster tender, fence erector (non-steel/iron), flag person, highway stripers, landscaper, and traffic barrier erector.	Yes <input type="checkbox"/>	No <input type="checkbox"/>	N/A <input checked="" type="checkbox"/>	Yes <input type="checkbox"/>	No <input type="checkbox"/>
<b>Lubrication and Service Engineer</b>	Yes <input type="checkbox"/>	No <input type="checkbox"/>	N/A <input checked="" type="checkbox"/>	Yes <input type="checkbox"/>	No <input type="checkbox"/>
<b>Mechanical Insulator</b>	Yes <input type="checkbox"/>	No <input type="checkbox"/>	N/A <input checked="" type="checkbox"/>	Yes <input type="checkbox"/>	No <input type="checkbox"/>
<b>Millwright</b>	Yes <input type="checkbox"/>	No <input type="checkbox"/>	N/A <input checked="" type="checkbox"/>	Yes <input type="checkbox"/>	No <input type="checkbox"/>
<b>Operating Engineer</b> , can also include equipment greaser, piledriver, soils and material tester, steel fabricator/erector (equipment) and surveyor (non-licensed) and well driller.	Yes <input type="checkbox"/>	No <input type="checkbox"/>	N/A <input checked="" type="checkbox"/>	Yes <input type="checkbox"/>	No <input type="checkbox"/>
<b>Painters and Allied Trades</b> , can also include glaziers, floor coverers, and tapers.	Yes <input type="checkbox"/>	No <input type="checkbox"/>	N/A <input checked="" type="checkbox"/>	Yes <input type="checkbox"/>	No <input type="checkbox"/>

\*This is intended as a "Sample Form" only and is not an official or approved form of the Office of the Labor Commissioner. \*

	Yes	No	N/A	✓	Yes	No
Pile Driver (non-equipment)	<input type="checkbox"/>	<input type="checkbox"/>	<input checked="" type="checkbox"/>	<input type="checkbox"/>	<input type="checkbox"/>	<input type="checkbox"/>
Plasterer	<input type="checkbox"/>	<input type="checkbox"/>	<input checked="" type="checkbox"/>	<input type="checkbox"/>	<input type="checkbox"/>	<input type="checkbox"/>
Plumber/Pipefitter	<input type="checkbox"/>	<input checked="" type="checkbox"/>	<input type="checkbox"/>	<input type="checkbox"/>	<input type="checkbox"/>	<input checked="" type="checkbox"/>
Refrigeration	<input type="checkbox"/>	<input type="checkbox"/>	<input checked="" type="checkbox"/>	<input type="checkbox"/>	<input type="checkbox"/>	<input type="checkbox"/>
Roofer (not sheet metal)	<input type="checkbox"/>	<input type="checkbox"/>	<input checked="" type="checkbox"/>	<input type="checkbox"/>	<input type="checkbox"/>	<input type="checkbox"/>
Sheet Metal Worker, can also include air balance technician.	<input type="checkbox"/>	<input checked="" type="checkbox"/>	<input type="checkbox"/>	<input type="checkbox"/>	<input type="checkbox"/>	<input checked="" type="checkbox"/>
Soils and Materials Tester, includes certified soil tester	<input type="checkbox"/>	<input type="checkbox"/>	<input checked="" type="checkbox"/>	<input type="checkbox"/>	<input type="checkbox"/>	<input type="checkbox"/>
Sprinkler Fitter	<input type="checkbox"/>	<input type="checkbox"/>	<input checked="" type="checkbox"/>	<input type="checkbox"/>	<input type="checkbox"/>	<input type="checkbox"/>
Surveyor (non-licensed)	<input type="checkbox"/>	<input type="checkbox"/>	<input checked="" type="checkbox"/>	<input type="checkbox"/>	<input type="checkbox"/>	<input type="checkbox"/>
Taper	<input type="checkbox"/>	<input type="checkbox"/>	<input checked="" type="checkbox"/>	<input type="checkbox"/>	<input type="checkbox"/>	<input type="checkbox"/>
Tile/Terrazzo Worker/Marble Mason	<input type="checkbox"/>	<input type="checkbox"/>	<input checked="" type="checkbox"/>	<input type="checkbox"/>	<input type="checkbox"/>	<input type="checkbox"/>
Traffic Barrier Erector (See Laborers)	<input type="checkbox"/>	<input type="checkbox"/>	<input checked="" type="checkbox"/>	<input type="checkbox"/>	<input type="checkbox"/>	<input type="checkbox"/>
Truck Driver	<input type="checkbox"/>	<input type="checkbox"/>	<input checked="" type="checkbox"/>	<input type="checkbox"/>	<input type="checkbox"/>	<input type="checkbox"/>
Well Driller (see also Operating Engineer)	<input type="checkbox"/>	<input type="checkbox"/>	<input checked="" type="checkbox"/>	<input type="checkbox"/>	<input type="checkbox"/>	<input type="checkbox"/>
Other*:	<input type="checkbox"/>	<input type="checkbox"/>	<input type="checkbox"/>	<input type="checkbox"/>	<input type="checkbox"/>	<input type="checkbox"/>
	<input type="checkbox"/>	<input type="checkbox"/>	<input type="checkbox"/>	<input type="checkbox"/>	<input type="checkbox"/>	<input type="checkbox"/>
	<input type="checkbox"/>	<input type="checkbox"/>	<input type="checkbox"/>	<input type="checkbox"/>	<input type="checkbox"/>	<input type="checkbox"/>
	<input type="checkbox"/>	<input type="checkbox"/>	<input type="checkbox"/>	<input type="checkbox"/>	<input type="checkbox"/>	<input type="checkbox"/>

Exhibit A

I affirm I am fully authorized to acknowledge, on behalf of the Contractor listed above, the anticipated workforce, and acknowledge that changes to the anticipated workforce which may have an impact on compliance with the Nevada Apprenticeship Utilization Act, 2019 will require the submittal of a revised form within ten (10) working days of such change.

Signed:   
 Name and Title: Ryan Novacek Sales Mgr.  
 Date: 2/14/23  
 Contractor Name: ACCO Engineered Systems, Inc.

\*This is intended as a "Sample Form" only and is not an official or approved form of the Office of the Labor Commissioner. \*





## STAFF REPORT

**Report To:** Board of Supervisors **Meeting Date:** March 2, 2023

**Staff Contact:** Ali Banister, Chief Juvenile Probation

**Agenda Title:** For Possible Action: Discussion and possible action regarding the proposed acceptance of Partnership Carson City's ("PCC") Comprehensive Opioid, Simulant, and Substance Abuse Program ("COSSAP") subgrant funds in the amount of \$90,000, effective January 1, 2023 through August 14, 2023, to be used for an additional full time employee ("FTE") and related expenses, such as training and travel, for a Juvenile Outreach Specialist, and the proposed acceptance of two additional subgrants if they are awarded, each for the same amount per year and for the same purpose through August 14, 2025, for a total award of \$270,000. (Ali Banister, abanister@carson.org)

Staff Summary: PCC has received a COSSAP Grant and has offered to supply \$90,000 per year of their grant funds to reimburse Carson City for three years to fund a Juvenile Outreach Specialist FTE and related expenses to assist the Carson City Juvenile Detention/Probation Department of the First Judicial District Court ("Juvenile Services") to bring a more cohesive solution to assist the community with services for at-risk juveniles. While PCC has stated that it will provide this grant to Juvenile Services for three years, only the first year is before the Board of Supervisors ("Board") for immediate approval because PCC receives a COSSAP grant one year at a time. However, this agenda item also requests advance authorization for acceptance of the grant funds for the next two years if they are awarded.

**Agenda Action:** Formal Action / Motion **Time Requested:** 5 minutes

---

### **Proposed Motion**

I move to authorize acceptance of the subgrant in the amount of \$90,000 as requested and authorize the acceptance of two additional subgrants from the same source, each for the same amount per year for the next two years if they are awarded and subject to the same grant terms and conditions.

### **Board's Strategic Goal**

Quality of Life

### **Previous Action**

N/A

### **Background/Issues & Analysis**

Carson City Juvenile Services has identified a strong need for a Juvenile Outreach Specialist to assist Juvenile Services to provide a more cohesive solution for services for at-risk youth. A supplemental request to add a grant funded Juvenile Outreach Specialist position was approved by the Board as part of the Fiscal Year ("FY") 2023 budget process pending the award of a grant from PCC.

Separately, the State of Nevada Attorney General's Office, PCC and the Nye Communities Coalition applied for the United States Bureau of Justice Assistance ("BJA") Comprehensive Opioid, Simulant, and Substance Abuse Program ("COSSAP") grant and each were awarded \$1,065,097 in grant funding. Through working with PCC, PCC has agreed to award a sub grant of COSSAP funds to Juvenile Services to fund the Juvenile Outreach Specialist FTE \$90,000 per year for three years until August 14, 2025.

Juvenile Services will request that Carson City fund the position starting on August 15, 2025 forward, if grant funding is no longer available.

**Applicable Statute, Code, Policy, Rule or Regulation**

Carson City Grants Administration Policy

**Financial Information**

**Is there a fiscal impact?** Yes

**If yes, account name/number:** Grant Fund: G270523006 2752081 431010

**Is it currently budgeted?** No

**Explanation of Fiscal Impact:** The City will receive up to \$90,000 in COSSAP sub grant funds from the PCC for the position for FYs 2023 and 2024 through August 14, 2023. The FY 2023 budget will be augmented with the grant funds during the second round of budget augmentations.

**Alternatives**

Do not authorize acceptance of the grant and/or provide alternative direction to staff.

**Attachments:**

[PCC Whole Grant Award Ltr.pdf](#)

[COSSAP NOSA unsigned.pdf](#)

[PCC Award Ltr.pdf](#)

[PCC COSSAP Terms and Conditions.pdf](#)

**Board Action Taken:**

Motion: _____	1) _____	Aye/Nay
	2) _____	_____
		_____
		_____
		_____

\_\_\_\_\_  
(Vote Recorded By)

**Nevada Office of the Attorney General**  
**FFY21 Comprehensive Opioid, Stimulant, and Substance Abuse Program (COSSAP)**  
**Sub-Grant Award**

<b>Sub-Grantee:</b>	Partnership Carson City	<b>Total Award:</b>	\$	1,065,097.00
<b>Sub-Grant Number:</b>	2021-COSSAP-04	<b>Total Match:</b>	\$	-
<b>Address:</b>	1925 N. Carson Street Carson City, NV 89701	<b>Total Project Cost:</b>	\$	1,065,097.00
<b>Contact Name:</b>	Hannah McDonald	<b>Project Period:</b>	August 15, 2022 through August 14, 2023	
<b>Phone Number:</b>	775-841-4790	<b>Indirect Rate:</b>	N/A	
<b>Email Address:</b>	<a href="mailto:hannah@pcccarson.org">hannah@pcccarson.org</a>	<b>UEI:</b>	TMDZ243MFKK7	
<b>Project Title:</b>	NPCC COSSAP Project		<b>CCR/SAM Expiration:</b>	1/9/2023

Approved Budget for Project		CFDA No.:	16.838
<b>Category</b>		<b>FEDERAL AWARD #</b>	15PBIA-21-GG-04508-COAP
Personnel	\$ 131,358.00	<b>Federal Award Date:</b>	12/22/2021
Fringe Benefits	\$ -	<b>Total Federal Award:</b>	\$5,751,772
Travel	\$ 7,848.00	<b>Federal Awarding Agency:</b>	U.S. Dept. of Justice, Bureau of Justice Assistance
Equipment	\$ -	<b>State Awarding Agency:</b>	Nevada Office of the Attorney General
Supplies/Operating	\$ 26,000.00	<b>State Authorizing Official:</b>	Debbie Tanaka on behalf of Attorney General Aaron D. Ford
Construction	\$ -	<b>Phone Number:</b>	775-684-1110
Consultant/Contracts	\$ 854,090.00	<b>Email Address:</b>	<a href="mailto:dtanaka@ag.nv.gov">dtanaka@ag.nv.gov</a>
Training	\$ 7,800.00	<b>Address:</b>	Nevada Office of the Attorney General 100 N. Carson Street Carson City, NV 89701
Indirect	\$ 38,001.00	<b>Federal Project Description:</b>	The Comprehensive Opioid, Stimulant, and Substance Abuse Program (COSSAP) was developed as part of the Comprehensive Addiction and Recovery Act (CARA) legislation. COSSAP's purpose is to provide financial and technical assistance to states, units of local government, and Indian tribal governments to develop, implement, or expand comprehensive efforts to identify, respond to, treat, and support those impacted by illicit opioids, stimulants, and other drugs of abuse. COSSAP aims to reduce the impact of opioids, stimulants, and other substances on individuals and communities, including a reduction in the number of overdose fatalities, as well as mitigate the impacts on crime victims by supporting comprehensive, collaborative initiatives.
<b>Total Award</b>	\$ 1,065,097.00		

This award is subject to the federal guidelines established by the Department of Justice, Bureau of Justice Assistance.  
 **TERMS AND CONDITIONS:** This project is approved subject to such special conditions or limitations as set forth on the attached page(s).

<b>AGENCY APPROVAL</b>	
<b>Aaron D. Ford, Attorney General</b>	
<i>Name and title of Appointing Official</i>	
By: Debbie M. Tanaka, Grants Manager	
x 	/ 1/5/23
<i>Signature of Approving Official/Date</i>	

<b>SUBGRANTEE ACCEPTANCE</b>	
Hannah McDonald Executive Director	Jack Araza Board Chair
<i>Printed name and title of Executive Director or Equivalent</i>	
x  12/23/2022	x  1-2-23
<i>Signature of Executive Director or Equivalent and Date</i>	

**Partnership Carson City  
2023 NOTICE OF SUBGRANT AWARD  
COSSAP**

<p><b>Coalition:</b> Partnership Carson City DUNS: 13 526 9756</p>	<p><b>Sub Grantee Name:</b> Carson City Juvenile Services</p>																					
<p><b>Address:</b> 1925 N. Carson Street Carson City, NV 89701</p>	<p><b>Address:</b> 740 S. Saliman Carson City, Nevada 89701</p>																					
<p><b>Sub Grant Period:</b> January 1, 2023 – August 14, 2023</p>	<p><b>Sub Grantee EIN#:</b> 88-6000189</p> <p><b>Sub Grantee DUNS#:</b> (No Longer Used)</p> <p><b>Sub Grantee UFI#:</b> DTBPJMA2QFC8</p> <p><b>SAM Registration Expiration:</b> June 24, 2023</p>																					
<p><b>Reason for Award:</b> To fund an Outreach Specialist to provide services and referrals to high-risk clients. Services to include early intervention programs, diversion, evidence-based education groups in the community and community service.</p>																						
<p><b>County(ies) to be served:</b> Carson City and Storey County</p>																						
<p><b>Approved Budget Categories:</b></p> <table style="width: 100%; border-collapse: collapse;"> <tr> <td style="width: 70%;">1. Personnel</td> <td style="width: 10%; text-align: center;">\$</td> <td style="width: 20%; text-align: right;">90,000.00</td> </tr> <tr> <td>2. Contractual/Consultant</td> <td style="text-align: center;">\$</td> <td style="text-align: right;">XXX</td> </tr> <tr> <td>3. Travel</td> <td style="text-align: center;">\$</td> <td style="text-align: right;">XXX</td> </tr> <tr> <td>4. Training</td> <td style="text-align: center;">\$</td> <td style="text-align: right;">XXX</td> </tr> <tr> <td>5. Operating</td> <td style="text-align: center;">\$</td> <td style="text-align: right;">XXX</td> </tr> <tr> <td>6. Other</td> <td style="text-align: center;">\$</td> <td style="text-align: right;">XXX</td> </tr> <tr> <td style="text-align: right;"><b>Total Cost</b></td> <td style="text-align: center;"><b>\$</b></td> <td style="text-align: right;"><b>XXX</b></td> </tr> </table>		1. Personnel	\$	90,000.00	2. Contractual/Consultant	\$	XXX	3. Travel	\$	XXX	4. Training	\$	XXX	5. Operating	\$	XXX	6. Other	\$	XXX	<b>Total Cost</b>	<b>\$</b>	<b>XXX</b>
1. Personnel	\$	90,000.00																				
2. Contractual/Consultant	\$	XXX																				
3. Travel	\$	XXX																				
4. Training	\$	XXX																				
5. Operating	\$	XXX																				
6. Other	\$	XXX																				
<b>Total Cost</b>	<b>\$</b>	<b>XXX</b>																				
<p><b>Disbursement of funds will be as follows:</b> Payment will be made upon receipt and acceptance of an invoice and supporting documentation specifically requesting reimbursement for actual expenditures <i>specific to this sub grant</i>. Total reimbursement will not exceed \$90,000.00 during the sub grant period.</p>																						
<b>Source of Funds:</b>	<b>Amount:</b>	<b>% of Funds:</b>	<b>CFDA#:</b>	<b>Federal Grant #:</b>																		
1. This award is subject to the federal guidelines established by the Department of Justice, Bureau of Justice Assistance, and is awarded to Partnership Carson City Through the Nevada Attorney General's Office.	\$90,000.00	100%	16.838	15PBJA-21-GG-04508-COAP																		
<p><b>Terms and Conditions</b> In accepting these grant funds, it is understood that:</p> <ol style="list-style-type: none"> <li>1. Expenditures must comply with appropriate state and/or federal regulations.</li> <li>2. This award is subject to the availability of appropriate funds.</li> <li>3. Recipient of these funds agrees to stipulations listed in Sections A-C, and Attachments A-B of this sub grant award.</li> <li>4. By signing you are agreeing to follow the attached scope of work (SOW) and the attached detailed budget.</li> </ol>																						
Lori Bagwell Mayor		Date																				
Hannah McDonald Executive Director		Date																				
Samantha Szoyka Deputy Director		Date																				

**Partnership Carson City  
NOTICE OF SUB GRANT AWARD**

**SECTION A  
Assurances**

As a condition of receiving sub granted funds from Partnership Carson City (PCC), the Sub grantee agrees to the following conditions:

1. Approval of sub grant budget by PCC constitutes prior approval for the expenditure of funds for specified purposes included in this budget.
2. Sub grantee agrees grant funds may not be used for any other purpose than the awarded purpose. In the event sub grantee expenditures do not comply with this condition, that portion not in compliance will not be reimbursed to the sub grantee or must be refunded to PCC.
3. Sub grantee acknowledges that this sub grant and the continuation of this sub grant is contingent upon sufficient funds being appropriated, budgeted, and otherwise made available by the State Legislature and/or federal sources. If funds become unavailable PCC may restrict, reduce, or terminate funding under this award. Notice of any restriction or reduction will include instructions and detailed information on how PCC will fund the services and/or goods to be procured with the restricted or reduced funds.
4. Sub grantee acknowledges that to better address the needs of Nevada, funds identified in this sub grant may be reallocated if any terms of the sub grant are not met, including failure to meet the scope of work. PCC may reallocate funds to other programs to ensure that gaps in service are addressed. If the scope of work is not being met, sub grantees will be provided a chance to develop an action plan on how the scope of work will be met and technical assistance will be provided by PCC staff. The sub grantee will have 60 days to improve the scope of work and carry out the approved action plan. If performance has not improved, PCC will provide a written notice identifying the reduction of funds and the necessary steps.
5. Unless specified by PCC, any changes to the approved sub grant that will result in an amendment must be received within the timeframe specified in Section B, prior to the end of the sub grant period. Amendment requests received after the deadline will be denied.
6. Sub grantee acknowledges that requests to revise the approved sub grant must be made in writing using the appropriate forms and provide sufficient narrative detail to determine justification. Expenses that are incurred without prior PCC approval may not be reimbursed. PCC has the authority to require an amendment for any change (Section B), but will generally follow these parameters in the process of determining whether an amendment is needed:
  - a. Any overall increases or decreases to the award will require an amendment.
  - b. Any changes to the Scope of Work will require an amendment.
    - i. A printed and signed copy of the Scope of Work Summary must be included.
  - c. Numerous changes to the budget over the course of the budget period and the nature of the changes could result in PCC requiring an amendment.
7. Sub grantee must be in compliance with all state, local and federal laws and ordinances governing the type of facility or program receiving PCC funding, including all licensure and certifications required. In particular, recipients of state funding must have the following:
  - a. State Business License or proof of eligibility for State Business License exemption. Further information can be found on the Secretary of State website: <http://nvsos.gov>
  - b. An Employer Identification Number (EIN), issued by the IRS for the purpose of tax administration.

- c. A current Vendor Number obtained through the State Controller's Office. This must be updated whenever there is a change to any information on the form including:
    - i. Sub grantee's bank / bank account
    - ii. Business address
  - d. An active Dun and Bradstreet Universal Number System (DUNS) as required by the Federal Funding Accountability and Transparency Act.
  - e. Enrollment in the System Award Management (SAM) and Unique Entity Identification (UEI) as required by the Federal Funding Accountability and Transparency Act.
8. Recipients of sub grants are required to maintain sub grant accounting records, identifiable by sub grant number. Such records shall be maintained in accordance with the following:
- a. Records may be destroyed by the sub grantee six (6) calendar years after the final financial and narrative reports have been submitted to the PCC.
  - b. In all cases an overriding requirement exists to retain records until notified in writing of resolution of any audit questions relating to individual sub grants.

Sub grant accounting records are considered to be all records relating to the expenditure and reimbursement of funds awarded under this sub grant award. Records required for retention includes all accounting records and related original and supporting documents that substantiate costs charged to the sub grant activity.

9. Restrictions on Expenditure of Funds: Sub grantees will not expend PCC funds, for any of the following purposes:
- a. To purchase or improve land: purchase, construct, or permanently improve, other than minor remodeling, any building or other facility; or purchase major medical equipment.
  - b. To make any one purchase, including equipment, over \$2,000.
  - c. To satisfy any requirement for the expenditure of non-federal funds as a condition for the receipt of federal funds.
10. Federal Funds will not be awarded to any entity other than a public or nonprofit private entity or city agency include sheriff's departments, health divisions, private contractors, etc.
11. Sub grants are subject to inspection and audit by representatives of PCC, the Division of Public and Behavioral Health, Nevada Department of Health and Human Services, the State Department of Administration, the Audit Division of the Legislative Counsel Bureau or other appropriate state or federal agencies to:
- a. Verify financial transactions and determine whether funds were used in accordance with applicable laws, regulations and procedures;
  - b. Ascertain whether policies, plans and procedures are being followed;
  - c. Provide management with objective and systematic appraisals of financial and administrative controls, including information as to whether operations are carried out effectively, efficiently and economically;
  - d. Determine reliability of financial aspects of the conduct of the project; and
  - e. Chapter 218 of the NRS states that the Legislative Auditor, as directed by the Legislative Commission pursuant to NRS 218.340, shall conduct a special audit of an entity which is not an agency of this State but which receives an appropriation of public money during any fiscal year. The sub grantee agrees to make available to the Legislative Auditor of the State of Nevada all books, accounts, claims, reports, vouchers or other records of information that the Legislative Auditor determines to be necessary to conduct an audit pursuant to NRS 218.
12. Audits or year-end financial reports are required of sub grantees receiving funds. Refer to Section D for the annual audit policy and requirements from the Division of Public and Behavioral Health, Behavioral Health Prevention and Treatment.



13. Sub grantee shall provide PCC with renewal or replacement evidence of insurance no less than thirty days before the expiration or replacement of the required insurance. Sub grantee shall provide proof of worker's compensation insurance as required by Nevada Revised Statutes Chapters 616A through 616D inclusive. Commercial general liability insurance shall be on an occurrence basis and shall be at least as broad as ISO 1996 form CG 00 01 (or a substitute a form providing equivalent coverage); and shall cover liability arising from premises, operations, independent contractors, completed operations, personal injury, products, civil lawsuits, Title VII actions and liability assumed under an insured contract (including the tort liability of another assumed in a business contract). PCC shall be named as the Certificate Holder on the Certificate of Liability Insurance.
14. Sub grantee agrees to disclose any existing or potential conflicts of interest relative to the performance of services resulting from this sub grant award. PCC reserves the right to disqualify any grantee on the grounds of actual or apparent conflict of interest. Any attempt to intentionally or unintentionally conceal or obfuscate a conflict of interest will automatically result in the disqualification of funding.
15. Sub grantee agrees to comply with the requirements of the Civil Rights Act of 1964, as amended, and the Rehabilitation Act of 1973, P.L. 93-112, as amended, and any relevant program-specific regulations, and shall not discriminate against any employee or offer or for employment because of race, national origin, creed, color, gender, religion, age, sexual preference, disability or handicap condition (including AIDS and AIDS-related conditions).
16. Sub grantee agrees to comply with the Americans with Disabilities Act of 1990 (P.L. 101-136), 42 U.S.C. 12101, as amended, and regulations adopted there under contained in 28 CFR 26.101-36.999 inclusive, and any relevant program-specific regulations.
17. Sub grantee agrees to comply with the requirements of the Health Insurance Portability and Accountability Act of 1996, 45 C.F.R. 160, 162 and 164, as amended. If the sub grant award includes functions or activities that involve the use or disclosure of Protected Health Information, the Sub grantee agrees to enter into a Business Associate Agreement with PCC, as required by 45 C.F.R 164.504 (e).
18. Sub grantee certifies, by signing this sub grant, that neither it nor its principals are presently debarred, suspended, proposed for debarment, declared ineligible, or voluntarily excluded from participation in this transaction by any federal department or agency. This certification is made pursuant to regulations implementing Executive Order 12549, Debarment and Suspension, 28 C.F.R. pt. 67 § 67.510, as published as pt. VII of May 26, 1988, Federal Register (pp.19150-19211). This provision shall be required of every sub grantee receiving any payment in whole or in part from federal funds.
19. Sub grantee agrees, whether expressly prohibited by federal, state, or local law, or otherwise, that no funding associated with this sub grant will be used for any purpose associated with or related to lobbying or influencing or attempting to lobby or influence for any purpose the following:
  - a. Any federal, state, county or local agency, legislature, commission, counsel, or Board;
  - b. Any federal, state, county or local legislator, commission member, council member, Board member, or other elected official; or
  - c. Any officer or employee of any federal, state, county or local agency, legislature, commission, counsel, or Board.
20. Indemnification: To the fullest extent permitted by law sub grantee shall indemnify, hold harmless and defend, not excluding the State's right to participate, the State from and against all liability, claims, actions, damages, losses, and expenses, including, without limitation, reasonable attorneys' fees and costs, arising out of any alleged negligent or willful acts or omissions of Sub grantee, its officers, employees and agents.
21. Sub grantees will report within 24 hours the occurrence of an incident, which may cause imminent danger to the health or safety of the clients, participants, staff of the program, or a visitor to the program. [NAC 458.153 3(e)].

22. Sub grantee agrees to participate in reporting all required data and information through the SAPTA data reporting system and to the evaluation team as required; or, if applicable, another qualified Electronic Health Record reporting system (EHR).
23. Sub grantee will:
  - a. Be a "tobacco, alcohol, and other drug free" environment in which the use of tobacco products, alcohol, and illegal drugs will not be allowed;
  - b. Have documentation on file verifying Nevada Repository and FBI background checks every 5 years were conducted on all staff, volunteers, and consultants occupying clinical and supportive roles, if sub grantee serves minors with funds awarded through this sub grant;
  - c. Adopt and maintain a system of internal controls consistent with Generally Accepted Accounting (GAAP) principles that results in the fiscal integrity and stability of the organization;
  - d. Comply with all applicable rules, regulations, requirements, guidelines, and policies and procedures to include, but not limited to:
    - i. 75 CFR Part 74
    - ii. OMB Circular A-133
    - iii. All applicable funding source requirements
    - iv. All other federal rules related to federal funding
    - v. Chapter 458 of the Nevada Revised Statutes
    - vi. Chapter 458 of the Nevada Administrative Code
    - vii. Substance Abuse Prevention and Treatment Agency policies and procedures
    - viii. All other applicable state regulations and policies, and
    - ix. All terms listed within this award
24. Certification must be current and fees paid prior to release of certificate in order to receive funding from the PCC.
25. Sub grantee will identify the source of funding on all printed and electronic documents purchased or produced within the scope of this sub grant, using the current approved attribution statement.
26. Failure to meet any condition listed within the sub grant award may result in withholding reimbursement payments, disqualification of future funding, and/or termination of current funding.



**Partnership Carson City  
2022 – 2023 NOTICE OF SUB GRANT AWARD**

**SECTION B  
Prevention Services Additional Assurances**

Sub grantee, also agrees to:

1. Submit any changes to the approved sub grant that will result in an amendment, to be received by PCC 60 days prior to the end of the sub grant period. Amendment requests received after the 60-day deadline will be denied. Simple changes can be made up to July 10<sup>th</sup> 2023.
2. Become coalition members and assist with efforts to implement the CSAP's Strategic Prevention Framework Planning Process:
3. Enter Session Activity Detail records at the start of each recurring program iteration.
4. Provide a program representative to attend Prevention training as listed below:
  - a. All full-time staff must annually complete a minimum of twenty (20) hours of training.
  - b. All part time staff must annually complete a minimum for ten (10) hours of training.
  - c. Participate in the implementation of evidence-based prevention programs, strategies, policies, and practices.
5. Participate in the implementation of the program provided evaluation tool (pre/posttest) by all sub recipients offering recurring direct service prevention programs: ensure that completed surveys are submitted to the PCC immediately following completion of the document. Should the program lack an evaluation tool
6. By signing this award you agree to follow the terms and conditions/ assurances within this document and the attached terms and conditions signed by Partnership Carson City with the BJA and AG offices.

**CONTACT INFORMATION:**

All questions or concerns should be directed to:

Partnership Carson City  
Hannah McDonald  
1925 N. Carson Street  
Carson City, NV 89701  
775-841-4730  
Hannah@pcccarson.org

**FUNDING SOURCE INFORMATION:**

- A. Substance Abuse Prevention and Treatment Block Grant (SAPTBG): According to SAPTBG, these funds are available to support all types of treatment and prevention for both alcohol and other drug abuse. This is federal funding passed through PCC to sub grantees.
- B. Substance Abuse Primary Prevention (SAPP): The purpose of this funding is to provide prevention efforts at the community level statewide that are focused on reducing the incidence of methamphetamine use. This is state general funding passed through PCC to sub grantees. The purpose of this funding is the implementation of evidence based direct service substance abuse prevention programs, practices, and strategies at the community level. This is state general funding passed through PCC to sub grantees.

- C. State Liquor Tax: The purpose of the state liquor tax dollars is to support secondary and tertiary programs; programs working with incarcerated individuals or those likely to recede. The dollars fund the Forensic Assessment Services Triage Team (FASTT) and supplemental programs such as Mobile Outreach Services Team (MOST).
- D. The Comprehensive Opioid, Stimulant, and Substance Abuse Program (COSSAP) was developed as part of the Comprehensive Addiction and Recovery Act (CARA) legislation. COSSAP's purpose is to provide financial and technical assistance to states, units of local government, and Indian tribal governments to develop, implement, or expand comprehensive efforts to identify, respond to, treat, and support those impacted by illicit opioids, stimulants, and other drugs of abuse. COSSAP aims to reduce the impact of opioids, stimulants, and other substances on individuals and communities, including a reduction in the number of overdose fatalities, as well as mitigate the impacts on crime victims by supporting comprehensive, collaborative initiatives.

**Partnership Carson City  
2023 NOTICE OF SUBGRANT AWARD**

**SECTION C  
Conditions and Reimbursement**

**Sub grantee, agrees to provide the following services and reports according to the identified timeframes:**

Provide all services as identified in the scope of work (Attachment A).

Conditions:

1. Quarterly reports will be due quarterly by the 10th of the month following each quarter. If the 10th of the month falls on a weekend, the report will be due by the first business day following the weekend.
2. Any items purchased that extend beyond the sub grant period (including, but not limited to, supplies, computers, monitors, televisions, and any other furniture or equipment) regardless of cost must be maintained on an inventory list by the sub grantee. Prior to reimbursement a copy of the packing list and a list of serial numbers and models must be submitted to PCC. The items must be able to be independently verified by location and serial number. PCC reserves the right to request equipment purchased using PCC funds is returned to PCC for use in another program.
3. Sub grantee will actively participate in coalition activities by assigning one or more representatives to a PCC task force, committee, or initiative.

**Sub grantee agrees to adhere to the following budget:**

Personnel	\$	\$90,000.00
Consultants/Contracts	\$	
Travel	\$	XXX
Training	\$	XXX
Operating	\$	XXX
Other	\$	
<b>Total Cost</b>	<b>\$</b>	<b>\$90,000.00</b>

**Reimbursement shall be on the following basis:**

1. A Request for Reimbursement will be submitted electronically to PCC and will include only items contained within the sub grant documents. Requests for advance of payment will not be considered or allowed.
2. Sub grantee will enter all required data into the SAPTA data reporting system and submit any required reporting prior to submitting a reimbursement request.
3. Sub grantee will submit, to PCC, the Request for Reimbursement and a supporting schedule summarizing the total amount and type of expenditures made during the reporting period within 10 days following the end of each month. A request must be submitted as a zero-dollar request if no expenses were incurred during the month.
4. Sub grantee agrees that submittal of the electronic reimbursement request constitutes an electronic signature and indicates that all source documentation is approved and on file with original signature when required.
5. Sub grantee must retain copies of approved travel claims, consultant invoices, payroll register indicating title, receipts for goods purchased, and any other relevant source documentation in support of reimbursement requests. The amount requested cannot exceed the amount of the actual expenditure.
6. Additional expenditure detail will be provided upon request from PCC. If additional detail or copies of backup documentation are requested by PCC, the information will be required to be given within 10 business days of the

request. Any costs requested without sufficient approved backup will be denied until such support can be produced.

7. Travel expenses, per diem, and other related expenses must conform to the procedures and rates allowed for State officers and employees.
8. Contracts, including lease agreements must be received by PCC prior to reimbursement payments.
9. PCC has the right to withhold reimbursement if any of the terms of the sub grant are not met, including the scope of work.

**Additionally, the sub grantee agrees to provide:**

1. A final Request for Reimbursement to PCC within **20 days** of the CLOSE OF THE SUBGRANT PERIOD. Any unobligated funds shall be returned to the State at that time, or if not already requested, shall be deducted from the final award.

**PCC agrees to:**

1. Process Requests for Reimbursement in a timely manner. PCC will reimburse sub grantees and contractors within 80 days of submittal and approval of documentation. Requests for reimbursement will be sent to [hannah@pccarson.org](mailto:hannah@pccarson.org) and [Lindsey@pccarson.org](mailto:Lindsey@pccarson.org)
2. Provide technical assistance to ensure compliance with sub grant and to maintain program integrity.
3. PCC reserves the right to reject requests for reimbursement under this sub grant until any delinquent forms, reports, and expenditure documentation are submitted to and accepted.

**Both parties agree:**

Program Compliance and Fiscal Monitors are a condition of receipt of funding. Programs receiving PCC funding are required to participate in both the certification and the monitor processes. A monitor is regulatory in nature and the purpose of a monitor is to accomplish the following:

1. Verify that funds are being utilized as identified in grant award documents.
2. Ensure that PCC funds programs in compliance with state and federal requirements and restrictions.
3. Identify problems or difficulties at an early point in time.
4. Coordinate the efficient delivery of services to Nevada's population.

**Termination:**

This sub grant agreement may be terminated by either party prior to the date set forth on the Notice of Sub Grant Award period, provided the termination shall not be effective until 30 days after a party has served written notice upon the other party. This agreement may be terminated by mutual consent of both parties or unilaterally by either party without cause. The parties expressly agree that this Agreement shall be terminated immediately if for any reason the division, state, and/or federal funding ability to satisfy this Agreement is withdrawn, limited, or impaired.

Partnership Carson City  
1925 N. Carson St.  
Carson City, NV 89701



Carson City Board of Supervisors  
Juvenile Probation and Detention

To Whom it May Concern,

Partnership Carson City has been awarded the Comprehensive Opioid, Stimulant, and Substance Abuse Program (COSSAP) Grant. Through a shared grant application with Partnership Carson City (PCC), Nye Communities Coalition and the Nevada Attorney General's Office PCC has been awarded \$1,065,987 each year for three years. The COSSAP, formerly the Comprehensive Opioid Abuse Program (COAP), was developed as part of the Comprehensive Addiction and Recovery Act (CARA) legislation. The cornerstone of BJA's COSSAP initiative is its emphasis on partnership and collaboration across the public health, behavioral health, and public safety sectors. Effective community responses leverage the combined expertise of each of these disciplines and rely upon unified and coordinated strategies. COSSAP's purpose is to provide financial and technical assistance to states, units of local government, and Indian tribal governments to develop, implement, or expand comprehensive efforts to identify, respond to, treat, and support those impacted by illicit opioids, stimulants and other drugs of abuse.

The BJA and the COSSAP funds they provide meet the goals and objectives are at the forefront of PCC; which is why PCC is honored to be funding Carson City Juvenile Detention/Probation department. The award amount for the department is \$90,000.00 each year for 3 years. There is additional paperwork to be processed before the department can begin to spend these funds. JPO will work with PCC to finalize a budget and scope of work that meets the grants deliverables.

PCC is thrilled to once again fund a staff member for JPO, and looks forward to a continued relationship.

For questions or concerns please call Hannah McDonald at 775-841-4730.

Thank you,

Hannah McDonald, Executive Director Partnership Carson City

## Partnership Carson City

### 2021 COMPREHENSIVE OPIOID, STIMULANT, AND SUBSTANCE ABUSE SITE-BASED PROGRAM (COSSAP) TERMS AND CONDITIONS

#### ACRONYMS:

HJA - Bureau of Justice Administration	NRS - Nevada Revised Statutes
CBO - Community Based Organization	NVOAG - Nevada Office of the Attorney General ("Recipient" or "Grantee")
CFR - Code of Federal Regulations	OIG - Office of the Inspector General
DOJ - (U.S.) Department of Justice	OJP - Office of Justice Programs
DUNS (Dun & Bradstreet) Data Universal Numbering System	OMB - (White House) Office of Management & Budget
EEOP - Equal Employment Opportunity Plan	PL - Public Law
FFATA - Federal Funding Accountability & Transparency Act	SMART - Office of Sex Offender Sentencing Monitoring Apprehending Registering and Tracking
FSRS - FFATA Sub-award Reporting System	USC - United States Code
GPRA - Government Performance & Results Act	
NPO/NGO - Non-profit Organization/Non- governmental Organization	

#### **By accepting and signing this award and initialing the Terms and Conditions,**

1. The sub-recipient/sub-grantee understands that funding is contingent upon available Federal funds and award levels may be increased or decreased during the course of the project period; and
2. The sub-recipient/sub-grantee understands and will comply with all applicable award conditions.
3. The sub-recipient/sub-grantee understands that it must not rely on this grant funding for sustainability beyond this award period

***Award Conditions include all Federal Pass-Through Special Conditions, State of Nevada/Nevada Office of Attorney General (NVOAG) conditions and any sub-recipient/sub-grantee specific conditions that are required to ensure full grant compliance.***

#### GENERAL COMPLIANCE CONDITIONS:

1. All awards are contingent upon sub-recipient/sub-grantee's submission of the signed Award Document, initialed Terms and Conditions, and applicable items identified in this document.
2. All sub-recipient/sub-grantee awards are contingent upon sub-recipient/sub-grantee having and maintaining current CCR/System for Award Management or SAM registration throughout the award period.
3. The sub-recipient/sub-grantee agrees to comply with applicable requirements regarding registration with the System for Award Management (SAM) (or with a successor government-wide system officially designated by OMB and DOJ). The sub-recipient/sub-grantee also agrees to comply with applicable restrictions on sub-awards to first-tier sub-recipients that do not acquire and provide a Data Universal Numbering System (DUNS) number. The details of recipient obligations are posted on the U.S. Department of Justice website at <http://www.ojw.usdoj.gov/docs/sam-award-term.pdf> (Award condition: Registration with the System for Award Management and Universal Identifier Requirements) and are incorporated by reference here. This condition does not apply to an award to an individual who received the award as a natural person (i.e., unrelated to any business or non-profit organization that he or she may own or operate in his or her name).





4. All sub-grant awards are contingent upon the sub-recipient/sub-grantee obtaining a current Vendor Registration Identification Number with the Nevada Office of the Controller and/or confirming the correct Vendor Number/payment address if their agency has multiple listings. This must be verified by the Fiscal Officer and returned with signed and initialed award documents. Verifications and corrections must be done by sub-recipient/sub-grantee on the Nevada Controller's website: <http://controller.nv.gov/VendorDB/About/Forms/>
5. Sub-recipient/sub-grantee must submit project related sub-contracts and/or sub-awards to NVOAG for approval prior to implementation of contracted project activities.
6. Approval of this award does not indicate approval of any consultant rate in excess of \$650 per day or \$81.25/hr. A detailed justification must be submitted to and approved by the NVOAG prior to obligation or expenditure of such funds.
7. Sub-recipient/sub-grantee agrees that all positions funded through the COSSAP grant must be doing the actual work identified in the approved application. The sub-recipient/sub-grantee also agrees that Personnel and Fringe expenses charged to COSSAP are reflective of the time worked on the funded project.
8. Sub-recipient/sub-grantee warrants that all personnel providing services hereunder are United States citizens or are fully and legally authorized to work in the United States. Failure to comply with the foregoing is grounds for immediate termination of this Agreement.
9. Sub-recipient/sub-grantee must provide job descriptions of staff funded and performing award-related activities. These must be submitted with executed award documents. Personnel changes and applicable job descriptions must be reported to and approved by NVOAG on a Project Change Notice (PCN) within thirty (30) days of occurrence. All staff funded by the award must be doing the work identified.
10. The sub-recipient/sub-grantee agrees that if they receive any funding that is duplicative of funding received under this grant, they will notify their NVOAG grant manager as soon as possible so that a PCN can be issued changing the budget and project activities to eliminate the duplication. Further, the sub-recipient/sub-grantee agrees and understands that any duplicative funding will be de-obligated from its award and returned to NVOAG.
11. The sub-recipient/sub-grantee acknowledges that failure to submit an acceptable EEOP (if organization is required to submit one pursuant to 28 CFR, Section 42.302), that is approved by the Office for Civil Rights (OCR), is a violation of the Standard Assurances executed by the organization, and may result in suspension of funding, until such time as the recipient is in compliance, or termination of the award.
12. The sub-recipient/sub-grantee agrees to comply with the applicable requirements of 28 CFR Part 38, the DOJ regulation governing "Equal Treatment for Faith Based Organizations" (the "Equal Treatment Regulation"). The Equal Treatment Regulation provides in part that DOJ grant awards of direct funding may not be used to fund any inherently religious activities, such as worship, religious instruction, or proselytization. Sub-recipient/sub-grantees of direct grants may still engage in inherently religious activities, but such activities must be separate in time or place from the DOJ funded program, and participation in such activities by individuals receiving services from a sub-recipient/sub-grantee must be voluntary. The Equal Treatment Regulation also makes clear that organizations participating in programs directly funded by the DOJ are not permitted to discriminate in the provision of services on the basis of a beneficiary's religion.
13. The sub-recipient/sub-grantee understands and agrees that award funds may not be used to discriminate against or denigrate the religious or moral beliefs of students who participate in programs for which financial assistance is provided from those funds, or the parents or legal guardians of such students.
14. The sub-recipient/sub-grantee agrees that awarded funds will be used to supplement, not supplant, non-federal funds that would otherwise be available for the activities under this grant.

15. The sub-recipient/sub-grantee understands and agrees that grant funds may be frozen and the award may be terminated if the sub-recipient/sub-grantee does not respond in a timely fashion to requests for information, to address compliance with any of the Terms and Conditions, and/or with NVOAG/OCFO/OIG audit/monitoring and findings.
16. The sub-recipient/sub-grantee understands and agrees that misuse of award funds may result in a range of penalties, including suspension of current and future funds, suspension or debarment from federal grants, recoupment of monies provided under an award, and civil and/or criminal penalties.
17. The NVOAG, upon a finding that there has been substantial failure by the sub-recipient/sub-grantee to comply with applicable laws, regulations, and/or the terms and conditions of the award or relevant solicitation, will terminate or suspend until the NVOAG is satisfied that there is no longer such failure, all or part of the award, in accordance with the provisions of 28 CFR Part 18, as applicable mutatis mutandis.
18. Sub-recipient/sub-grantee agrees that any changes in federal or state law and/or policies regarding grant compliance become part of the award and these Terms and Conditions upon receipt of written notification by postal or electronic mail delivery.
19. Sub-recipient/sub-grantee must retain all documents, including electronic records, related to this award for a minimum of three (3) years following the NVOAG acceptance of their final program and fiscal reports.

**REPORTING CONDITIONS:**

20. This is a cost reimbursable award. Sub-recipient/sub-grantee agrees to submit Monthly Reimbursement Reports (MFR) to NVOAG with all necessary back-up documentation to justify expenditures. MFRs must be submitted no later than the end of the month following the month of the claim period (*i.e. August 2022 MFR is due by September 30, 2022*), with the exception of June's MFR, which is due by July 15<sup>th</sup>. An MFR must be submitted monthly even if no reimbursement funds are requested. The signed MFR Back-Up Summary and supporting documentation must be submitted electronically to the [AGgrants@ag.ny.gov](mailto:AGgrants@ag.ny.gov) email address. There is no need to express mail the MFR and back up documentation.
21. Sub-recipient/sub-grantee understands all financial reimbursements are contingent upon full compliance with sub-recipient/sub-grantee award conditions. Unfulfilled compliance requirements lasting longer than sixty (60) calendar days may result in forfeiture of this award and denial of future funding.
22. NVOAG reserves the right to refuse MFR claims submitted past the date due. NVOAG also reserves the right to alter MFR due dates at the end of the grant period or in response to unforeseen circumstances upon electronic notification to sub-recipient/sub-grantee.
23. The sub-recipient/sub-grantee agrees to provide and cooperate with any assessments, information or documentation requests from NVOAG necessary to evaluate project progress, compliance and to process reimbursements.
24. Sub-recipient/sub-grantee agrees to comply with requirements for reporting identified at <https://www.cossapresources.org/Program/SiteGrants/Grantee/Management>.
25. Sub-recipient/sub-grantee agrees to submit Performance Management Reports to [AGgrants@ag.ny.gov](mailto:AGgrants@ag.ny.gov) by the 15<sup>th</sup> of the month following the end of the quarter for the duration of the grant.
26. The sub-recipient/sub-grantee and any of its sub-recipients must promptly refer to OIG and NVOAG any credible evidence that a principal, employee, agent, contractor, sub-recipient, subcontractor, or other person has 1) submitted a claim for award funds that violates the False Claims Act; or (2) committed a criminal or civil violation of laws pertaining to fraud, conflict of interest, bribery, gratuity, or similar misconduct involving award funds. Potential fraud, waste, abuse, or misconduct should be reported to the OIG and NVOAG by mail:

Office of the Attorney General

Office of the Inspector General

Page 3 of 15

August 2022

Authorizing Official Initials

AB

Board President/Equivalent Initials



Grants Unit  
Investigations Division  
100 North Carson Street  
Carson City, Nevada 89701-4717  
E-mail: [dtunaka@ag.nv.gov](mailto:dtunaka@ag.nv.gov)  
Phone: (775) 684-1110  
Fax: (775) 684-1102

U.S. Department of Justice  
Investigations Division – Grantee Reporting  
950 Pennsylvania Avenue, N.W.  
Washington, DC 20530  
Online: <https://oig.justice.gov/hotline/contact-grants.htm>  
Hotline (English & Spanish) (800) 869-4499  
Hotline Fax: (202) 616-9881

Additional information is available from the DOJ/OIG website at <https://oig.justice.gov/hotline>, or by contacting the NVOAG.

#### AWARD REQUIREMENTS

27. The conditions of this award are material requirements of the award. Compliance with any certifications or assurances submitted by or on behalf of the recipient that relate to conduct during the period of performance also is a material requirement of this award.

Failure to comply with any one or more of these award requirements -- whether a condition set out in full below, a condition incorporated by reference below, or a certification or assurance related to conduct during the award period -- may result in the Office of Justice Programs ("OJP") taking appropriate action with respect to the recipient and the award. Among other things, the OJP may withhold award funds, disallow costs, or suspend or terminate the award. The Department of Justice ("DOJ"), including OJP, also may take other legal action as appropriate.

Any materially false, fictitious, or fraudulent statement to the federal government related to this award (or concealment or omission of a material fact) may be the subject of criminal prosecution (including under 18 U.S.C. 1001 and/or 1621, and/or 34 U.S.C. 10271-10273), and also may lead to imposition of civil penalties and administrative remedies for false claims or otherwise (including under 31 U.S.C. 3729-3730 and 3801-3812)

Should any provision of a requirement of this award be held to be invalid or unenforceable by its terms, that provision shall first be applied with a limited construction so as to give it the maximum effect permitted by law. Should it be held, instead, that the provision is utterly invalid or -unenforceable, such provision shall be deemed severable from this award.

#### 28. Applicability of Part 200 Uniform Requirements

The Uniform Administrative Requirements, Cost Principles, and Audit Requirements in 2 C.F.R. Part 200, as adopted and supplemented by DOJ in 2 C.F.R. Part 2800 (together, the "Part 200 Uniform Requirements") apply to this FY 2021 award from OJP.

The Part 200 Uniform Requirements were first adopted by DOJ on December 26, 2014. If this FY 2021 award supplements funds previously awarded by OJP under the same award number (e.g., funds awarded during or before December 2014), the Part 200 Uniform Requirements apply with respect to all funds under that award number (regardless of the award date, and regardless of whether derived from the initial award or a supplemental award) that are obligated on or after the acceptance date of this FY 2021 award.

For more information and resources on the Part 200 Uniform Requirements as they relate to OJP awards and sub awards ("sub grants"), see the OJP website at <https://ojp.gov/funding/Part200UniformRequirements.htm>.

Record retention and access: Records pertinent to the award that the recipient (and any sub recipient ("sub grantee") at any tier) must retain -- typically for a period of 3 years from the date of submission of the final expenditure report (SF 425), unless a different retention period applies -- and to which the recipient (and any sub recipient ("sub grantee") at any tier) must provide access, include performance measurement information, in addition to the financial records, supporting documents, statistical records, and other pertinent records indicated at 2 C.F.R. 200.333.

In the event that an award-related question arises from documents or other materials prepared or distributed by OJP that may appear to conflict with, or differ in some way from, the provisions of the Part 200 Uniform Requirements, the recipient is to contact OJP promptly for clarification.

Furthermore, any sub-recipient using Office of Justice Programs grant funds, in whole or in part, to collect, aggregate, and/or share data on behalf of a government agency, must guarantee that the agency that owns the data and its approved designee(s) will retain unrestricted access to the data, in accordance with all applicable law, regulations, and BJA policy: a) in an expeditious manner upon request by the agency; b) in a clearly defined format that is open, user-friendly, and unfettered by unreasonable proprietary restrictions; and c) at a minimal additional cost to the requestor (which cost may be borne by using grant funds).

#### 29. Compliance with DOJ Grants Financial Guide

References to the DOJ Grants Financial Guide are to the DOJ Grants Financial Guide as posted on the OJP website (currently, Financial Guide <https://www.ojp.gov/funding/financialguidetodoj/overview> and 2 CFR 200 Uniform Guidance [https://www.ecfr.gov/cgi-bin/textidx?tpl=/ecfrbrowse/Title02/2cfr200\\_main\\_02.tpl](https://www.ecfr.gov/cgi-bin/textidx?tpl=/ecfrbrowse/Title02/2cfr200_main_02.tpl)), including any updated version that may be posted during the period of performance. The recipient agrees to comply with the DOJ Grants Financial Guide.

#### 30. Reclassification of various statutory provisions to a new Title 34 of the United States Code

On September 1, 2017, various statutory provisions previously codified elsewhere in the U.S. Code were editorially reclassified to a new Title 34, entitled "Crime Control and Law Enforcement." The reclassification encompassed a number of statutory provisions pertinent to OJP awards (that is, OJP grants and cooperative agreements), including many provisions previously codified in Title 42 of the U.S. Code.

Effective as of September 1, 2017, any reference in this award document to a statutory provision that has been reclassified to the new Title 34 of the U.S. Code is to be read as a reference to that statutory provision as reclassified to Title 34. This rule of construction specifically includes references set out in award conditions, references set out in material incorporated by reference through award conditions, and references set out in other award requirements

#### 31. Requirements related to "de minimis" indirect cost rate

A recipient that is eligible under the Part 200 Uniform Requirements and other applicable law to use the "de minimis" indirect cost rate described in 2 C.F.R. 200.414(f), and that elects to use the "de minimis" indirect cost rate, must advise OJP in writing of both its eligibility and its election, and must comply with all associated requirements in the Part 200 Uniform Requirements. The "de minimis" rate may be applied only to modified total direct costs (MTDC) as defined by the Part 200 Uniform Requirements.

#### 32. Requirement to report potentially duplicative funding

If the recipient currently has other active awards of federal funds, or if the recipient receives any other award of federal funds during the period of performance for this award, the recipient promptly must determine whether funds from any of those other federal awards have been, are being, or are to be used (in whole or in part) for one or more of the identical cost items for which funds are provided under this award. If so, the recipient must promptly notify the DOJ awarding agency (OJP or OVW, as appropriate) in writing of the potential duplication, and, if so requested by the DOJ awarding agency, must seek a budget-modification or change-of-project-scope grant adjustment notice (GAN) to eliminate any inappropriate duplication of funding.

#### 33. Requirement to report actual or imminent breach of personally identifiable information (PII)

The recipient (and any "sub recipient" at any tier) must have written procedures in place to respond in the event of an actual or imminent "breach" (OMB M-17-12) if it (or a sub recipient)-- 1) creates, collects, uses, processes, stores, maintains, disseminates, discloses, or disposes of "personally identifiable information (PII)" (2 CFR 200.79) within the scope of an OJP grant-funded program or activity, or 2) uses or operates a "Federal information system" (OMB

Circular A-130). The recipient's breach procedures must include a requirement to report actual or imminent breach of PII to an OJP Program Manager no later than 24 hours after an occurrence of an actual breach, or the detection of an imminent breach.

34. All sub awards ("sub grants") must have specific federal authorization

The recipient, and any sub recipient ("sub grantee") at any tier, must comply with all applicable requirements for authorization of any sub award. This condition applies to agreements that -- for purposes of federal grants administrative requirements -- OJP considers a "sub award" (and therefore does not consider a procurement "contract").

The details of the requirement for authorization of any sub award are posted on the OJP web site at <https://ojp.gov/funding/Explore/SubAwardAuthorization.htm> (Award condition: All sub awards ("sub grants") must have specific federal authorization), and are incorporated by reference here.

35. Specific post-award approval required to use a noncompetitive approach in any procurement contract that would exceed \$150,000

The recipient, and any sub recipient ("sub grantee") at any tier, must comply with all applicable requirements to obtain specific advance approval to use a noncompetitive approach in any procurement contract that would exceed the Simplified Acquisition Threshold (currently, \$150,000). This condition applies to agreements that -- for purposes of federal grants administrative requirements -- OJP considers a procurement "contract" (and therefore does not consider a sub sub award).

The details of the requirement for advance approval to use a noncompetitive approach in a procurement contract under an OJP award are posted on the OJP web site at <https://ojp.gov/funding/Explore/NoncompetitiveProcurement.htm> (Award condition: Specific post-award approval required to use a noncompetitive approach in a procurement contract (if contract would exceed \$150,000)), and are incorporated by reference here.

36. Requirements pertaining to prohibited conduct related to trafficking in persons (including reporting requirements and OJP authority to terminate award)

The recipient, and any sub recipient ("sub grantee") at any tier, must comply with all applicable requirements (including requirements to report allegations) pertaining to prohibited conduct related to the trafficking of persons, whether on the part of recipients, sub recipients ("sub grantees"), or individuals defined (for purposes of this condition) as "employees" of the recipient or of any sub recipient.

The details of the recipient's obligations related to prohibited conduct related to trafficking in persons are posted on the OJP web site at <https://ojp.gov/funding/Explore/ProhibitedConduct-Trafficking.htm> (Award condition: Prohibited conduct by recipients and sub recipients related to trafficking in persons (including reporting requirements and OJP authority to terminate award)), and are incorporated by reference here.

37. Compliance with applicable rules regarding approval, planning, and reporting of conferences, meetings, trainings, and other events

The recipient, and any sub recipient ("sub grantee") at any tier, must comply with all applicable laws, regulations, policies, and official DOJ guidance (including specific cost limits, prior approval and reporting requirements, where applicable) governing the use of federal funds for expenses related to conferences (as that term is defined by DOJ), including the provision of food and/or beverages at such conferences, and costs of attendance at such conferences. Information on the pertinent DOJ definition of conferences and the rules applicable to this award appears in the DOJ Grants Financial Guide (currently, as section 3.10 of "Post-award Requirements" in the "DOJ Grants Financial Guide").

38. Requirement for data on performance and effectiveness under the award

The recipient and sub recipient must collect and maintain data that measure the performance and effectiveness of work under this award. The data must be provided to OJP in the manner (including within the timeframes) specified by OJP in the program solicitation or other applicable written guidance. Data collection supports compliance with the Government Performance and Results Act (GPRA) and the GPRA Modernization Act of 2010, and other applicable laws.

#### 39. OJP Training Guiding Principles

Any training or training materials that the recipient -- or any sub recipient ("sub grantee") at any tier -- develops or delivers with OJP award funds must adhere to the OJP Training Guiding Principles for Grantees and Sub grantees, available at <https://ojp.gov/funding/Implement/TrainingPrinciplesForGrantees-Sub-grantees.htm>

<https://www.ojp.gov/funding/Implement/training-guiding-principles-grantees-and-subgrantees>

#### 40. Effect of failure to address audit issues

The recipient and sub recipient understand and agree that the DOJ awarding agency (OJP or OVW, as appropriate) may withhold award funds, or may impose other related requirements, if (as determined by the DOJ awarding agency) the recipient does not satisfactorily and promptly address outstanding issues from audits required by the Part 200 Uniform Requirements (or by the terms of this award), or other outstanding issues that arise in connection with audits, investigations, or reviews of DOJ awards.

#### 41. Potential imposition of additional requirements

The recipient agrees to comply with any additional requirements that may be imposed by the DOJ awarding agency (OJP or BJA, as appropriate) during the period of performance for this award, if the recipient is designated as "high-risk" for purposes of the DOJ high-risk grantee list.

#### 42. Compliance with DOJ regulations pertaining to civil rights and nondiscrimination - 28 C.F.R. Part 42

The recipient, and any sub recipient ("sub grantee") at any tier, must comply with all applicable requirements of 28 C.F.R. Part 42, specifically including any applicable requirements in Subpart E of 28 C.F.R. Part 42 that relate to an equal employment opportunity program.

#### 43. Compliance with DOJ regulations pertaining to civil rights and nondiscrimination - 28 C.F.R. Part 54

The recipient, and any sub recipient ("sub grantee") at any tier, must comply with all applicable requirements of 28 C.F.R. Part 54, which relates to nondiscrimination on the basis of sex in certain "education programs."

#### 44. Compliance with DOJ regulations pertaining to civil rights and nondiscrimination - 28 C.F.R. Part 38

The recipient, and any sub recipient ("sub grantee") at any tier, must comply with all applicable requirements of 28 C.F.R. Part 38, specifically including any applicable requirements regarding written notice to program beneficiaries and prospective program beneficiaries.

Among other things, 28 C.F.R. Part 38 includes rules that prohibit specific forms of discrimination on the basis of religion, a religious belief, a refusal to hold a religious belief, or refusal to attend or participate in a religious practice. Part 38 also sets out rules and requirements that pertain to recipient and sub recipient ("sub grantee") organizations that engage in or conduct explicitly religious activities, as well as rules and requirements that pertain to recipients and sub recipients that are faith-based or religious organizations.

The text of the regulation, now entitled "Partnerships with Faith-Based and Other Neighborhood Organizations," is available via the Electronic Code of Federal Regulations (currently accessible at <https://www.ecfr.gov/cgi-bin/ECFR?page=browse>), by browsing to Title 28-Judicial Administration, Chapter I, Part 38, under e-CFR "current" data.



45. Restrictions on "lobbying"

In general, as a matter of federal law, federal funds awarded by OJP may not be used by the recipient, or any sub recipient ("sub grantee") at any tier, either directly or indirectly, to support or oppose the enactment, repeal, modification, or adoption of any law, regulation, or policy, at any level of government. See 18 U.S.C. 1913. (There may be exceptions if an applicable federal statute specifically authorizes certain activities that otherwise would be barred by law.)

Another federal law generally prohibits federal funds awarded by OJP from being used by the recipient, or any sub recipient at any tier, to pay any person to influence (or attempt to influence) a federal agency, a Member of Congress, or Congress (or an official or employee of any of them) with respect to the awarding of a federal grant or cooperative agreement, sub grant, contract, subcontract, or loan, or with respect to actions such as renewing, extending, or modifying any such award. See 31 U.S.C. 1352. Certain exceptions to this law apply, including an exception that applies to Indian tribes and tribal organizations.

Should any question arise as to whether a particular use of federal funds by a recipient (or sub recipient) would or might fall within the scope of these prohibitions, the recipient is to contact OJP for guidance, and may not proceed without the express prior written approval of OJP.

46. Compliance with general appropriations-law restrictions on the use of federal funds (FY 2021)

The recipient, and any sub recipient ("sub grantee") at any tier, must comply with all applicable restrictions on the use of federal funds set out in federal appropriations statutes. Pertinent restrictions, including from various "general provisions" in the Consolidated Appropriations Act, 2021, are set out at <https://www.ojp.gov/funding/explore/overview>, and are incorporated by reference here

Should a question arise as to whether a particular use of federal funds by a recipient (or a sub recipient) would or might fall within the scope of an appropriations-law restriction, the recipient is to contact OJP for guidance, or the sub recipient is to notify the Grants Unit Manager at NVOAG who will contact OJP for guidance, and recipient and sub recipient may not proceed without the express prior written approval of OJP.

47. Reporting Potential Fraud, Waste, and Abuse, and Similar Misconduct

The recipient and any sub recipients ("sub grantees") must promptly refer to the DOJ Office of the Inspector General (OIG) any credible evidence that a principal, employee, agent, sub recipient, contractor, subcontractor, or other person has, in connection with funds under this award -- (1) submitted a claim that violates the False Claims Act; or (2) committed a criminal or civil violation of laws pertaining to fraud, conflict of interest, bribery, gratuity, or similar misconduct.

Potential fraud, waste, abuse, or misconduct involving or relating to funds under this award should be reported to the OIG by-- (1) mail directed to: Office of the Inspector General, U.S. Department of Justice, Investigations Division, 1425 New York Avenue, N.W. Suite 7100, Washington, DC 20530; and/or (2) the DOJ OIG hotline: (contact information in English and Spanish) at (800) 869-4499 (phone) or (202) 616-9881 (fax).

Additional information is available from the DOJ OIG website at <https://oig.justice.gov/hotline>.

48. Restrictions and certifications regarding non-disclosure agreements and related matters

No recipient or sub recipient ("sub grantee") under this award, or entity that receives a procurement contract or subcontract with any funds under this award, may require any employee or contractor to sign an internal confidentiality agreement or statement that prohibits or otherwise restricts, or purports to prohibit or restrict, the reporting (in accordance with law) of waste, fraud, or abuse to an investigative or law enforcement representative of a federal department or agency authorized to receive such information.

The foregoing is not intended, and shall not be understood by the agency making this award, to contravene requirements applicable to Standard Form 312 (which relates to classified information), Form 4414 (which relates to sensitive compartmented information), or any other form issued by a federal department or agency governing the nondisclosure of classified information.

1. In accepting this award, the recipient--

- a. represents that it neither requires nor has required internal confidentiality agreements or statements from employees or contractors that currently prohibit or otherwise currently restrict (or purport to prohibit or restrict) employees or contractors from reporting waste, fraud, or abuse as described above; and
- b. certifies that, if it learns or is notified that it is or has been requiring its employees or contractors to execute agreements or statements that prohibit or otherwise restrict (or purport to prohibit or restrict), reporting of waste, fraud, or abuse as described above, it will immediately stop any further obligations of award funds, will provide prompt written notification to the federal agency making this award, and will resume (or permit resumption of) such obligations only if expressly authorized to do so by that agency.

2. If the recipient does or is authorized under this award to make sub awards ("sub grants"), procurement contracts, or both--

a. it represents that--

- (1) it has determined that no other entity that the recipient's application proposes may or will receive award funds (whether through a sub award ("sub grant"), procurement contract, or subcontract under a procurement contract) either requires or has required internal confidentiality agreements or statements from employees or contractors that currently prohibit or otherwise currently restrict (or purport to prohibit or restrict) employees or contractors from reporting waste, fraud, or abuse as described above; and
- (2) it has made appropriate inquiry, or otherwise has an adequate factual basis, to support this representation; and

- b. it certifies that, if it learns or is notified that any sub recipient, contractor, or subcontractor entity that receives funds under this award is or has been requiring its employees or contractors to execute agreements or statements that prohibit or otherwise restrict (or purport to prohibit or restrict), reporting of waste, fraud, or abuse as described above, it will immediately stop any further obligations of award funds to or by that entity, will provide prompt written notification to the federal agency making this award, and will resume (or permit resumption of) such obligations only if expressly authorized to do so by that agency.

49. Compliance with 41 U.S.C. 4712 (including prohibitions on reprisal; notice to employees)

The recipient (and any sub recipient at any tier) must comply with, and is subject to, all applicable provisions of 41 U.S.C. 4712, including all applicable provisions that prohibit, under specified circumstances, discrimination against an employee as reprisal for the employee's disclosure of information related to gross mismanagement of a federal grant, a gross waste of federal funds, an abuse of authority relating to a federal grant, a substantial and specific danger to public health or safety, or a violation of law, rule, or regulation related to a federal grant.

The recipient also must inform its employees, in writing (and in the predominant native language of the workforce), of employee rights and remedies under 41 U.S.C. 4712.

Should a question arise as to the applicability of the provisions of 41 U.S.C. 4712 to this award, the recipient is to contact the DOJ awarding agency (OJP or OVW, as appropriate) for guidance.

50. Encouragement of policies to ban text messaging while driving

Pursuant to Executive Order 13513, "Federal Leadership on Reducing Text Messaging While Driving," 74 Fed. Reg. 51225 (October 1, 2009), DOJ encourages recipients and sub recipients ("sub grantees") to adopt and enforce policies banning employees from text messaging while driving any vehicle during the course of performing work funded by

this award, and to establish workplace safety policies and conduct education, awareness, and other outreach to decrease crashes caused by distracted drivers.

51. Requirement to disclose whether recipient is designated "high risk" by a federal grant-making agency outside of DOJ

If the recipient is designated "high risk" by a federal grant-making agency outside of DOJ, currently or at any time during the course of the period of performance under this award, the recipient must disclose that fact and certain related information to OJP by email at [OJP.ComplianceReporting@ojp.usdoj.gov](mailto:OJP.ComplianceReporting@ojp.usdoj.gov). For purposes of this disclosure, high risk includes any status under which a federal awarding agency provides additional oversight due to the recipient's past performance, or other programmatic or financial concerns with the recipient. The recipient's disclosure must include the following: 1. The federal awarding agency that currently designates the recipient high risk, 2. The date the recipient was designated high risk, 3. The high-risk point of contact at that federal awarding agency (name, phone number, and email address), and 4. The reasons for the high-risk status, as set out by the federal awarding agency.

52. The award recipient and sub-award recipients agree to participate in a data collection process measuring program outputs and outcomes. The data elements for this process will be outlined by the Office of Justice Programs.

53. Protection of human research subjects

The recipient (and any sub recipient at any tier) must comply with the requirements of 28 C.F.R. Part 46 and all OJP policies and procedures regarding the protection of human research subjects, including obtainment of Institutional Review Board approval, if appropriate, and subject informed consent.

54. Grantee and sub grantee agree that assistance funds awarded under this grant will not be used to support any inherently religious activities, such as worship, religious instruction, or proselytization. If the grantee refers participants to, or provides, a non-Federally funded program or service that incorporates such religious activities, (1) any such activities must be voluntary for program participants, and (2) program participants may not be excluded from participation in a program or otherwise penalized or disadvantaged for any failure to accept a referral or services. If participation in a non-Federally funded program or service that incorporates inherently religious activities is deemed a critical treatment or support service for program participants, the grantee agrees to identify and refer participants who object to the inherently religious activities of such program or service to, or provide, a comparable secular alternative program or service.

55. The recipient agrees to cooperate with any assessments, national evaluation efforts, or information or data collection requests, including, but not limited to, the provision of any information required for the assessment or evaluation of any activities within this project.

56. FFATA reporting: Sub awards, sub sub awards and executive compensation

The recipient must comply with applicable requirements to report first-tier sub awards ("sub grants") of \$30,000 or more and, in certain circumstances, to report the names and total compensation of the five most highly compensated executives of the recipient and first-tier sub recipients (first-tier "sub grantees") of award funds. The details of recipient obligations, which derive from the Federal Funding Accountability and Transparency Act of 2006 (FFATA), are posted on the OJP web site at <https://ojp.gov/funding/Explore/FFATA.htm> (Award condition: Reporting Sub awards and Executive Compensation), and are incorporated by reference here.

This condition, including its reporting requirement, does not apply to-- (1) an award of less than \$30,000, or (2) an award made to an individual who received the award as a natural person (i.e., unrelated to any business or non-profit organization that he or she may own or operate in his or her name).

57. Copyright; Data rights

The recipient and sub recipient acknowledge that OJP reserves a royalty-free, non-exclusive, and irrevocable license to reproduce, publish, or otherwise use, and authorize others to use (in whole or in part, including in connection with

derivative works), for Federal purposes: (1) any work subject to copyright developed under an award or sub award; and (2) any rights of copyright to which a recipient or sub recipient purchases ownership with Federal support.

The recipient and sub recipient acknowledge that OJP has the right to (1) obtain, reproduce, publish, or otherwise use the data first produced under an award or sub award; and (2) authorize others to receive, reproduce, publish, or otherwise use such data for Federal purposes. "Data" includes data as defined in Federal Acquisition Regulation (FAR) provision 52.227-14 (Rights in Data - General).

It is the responsibility of the recipient (and of each sub recipient, if applicable) to ensure that this condition is included in any sub award under this award.

The recipient has the responsibility to obtain from sub recipients, contractors, and subcontractors (if any) all rights and data necessary to fulfill the recipient's obligations to the Government under this award. If a proposed sub recipient, contractor, or subcontractor refuses to accept terms affording the Government such rights, the recipient shall promptly bring such refusal to the attention of the OJP program manager for the award and not proceed with the agreement in question without further authorization from the OJP program office.

With respect to any subject invention in which NVOAG or a sub award recipient or subcontractor retains title, the federal government shall have a nonexclusive, nontransferable, irrevocable, paid-up license to practice or have practiced for or on behalf of the United States the subject invention throughout the world. The sub award recipient or subcontractor will retain all rights provided for the award recipient in this clause, and the award recipient will not, as a part of the consideration for awarding the sub award, obtain rights in the sub award recipient's or subject inventions. Communication on matters relating to this Patent Rights Clause should be directed to IIR, which will review and forward them to the General Counsel, OJP, DOJ.

58. Any Web site that is funded in whole or in part under this award must include the following statement on the home page, on all major entry pages (i.e., pages (exclusive of documents) whose primary purpose is to navigate the user to interior content), and on any pages from which a visitor may access or use a Web-based service, including any pages that provide results or outputs from the service: "This Web site is funded in whole or in part through a grant from the Bureau of Justice Assistance, Office of Justice Programs, U.S. Department of Justice. Neither the U.S. Department of Justice nor any of its components operate, control, are responsible for, or necessarily endorse, this Web site (including, without limitation, its content, technical infrastructure, and policies, and any services or tools provided)." The full text of the foregoing statement must be clearly visible on the home page. On other pages, the statement may be included through a link, entitled "Notice of Federal Funding and Federal Disclaimer," to the full text of the statement.

59. The recipient and sub recipient agree to submit to BJA for review and approval any curricula, training materials, proposed publications, reports, or any other written materials that will be published, including web-based materials and web site content, through funds from this grant at least thirty (30) working days prior to the targeted dissemination date. Any written, visual, or audio publications, with the exception of press releases, whether published at the grantee's or government's expense, shall contain the following statements: "This project was supported by Grant No. 15PBJA-21-GG-04508-COAP awarded by the Bureau of Justice Assistance. The Bureau of Justice Assistance is a component of the Department of Justice's Office of Justice Programs, which also includes the Bureau of Justice Statistics, the National Institute of Justice, the Office of Juvenile Justice and Delinquency Prevention, the Office for Victims of Crime, and the SMART Office. Points of view or opinions in this document are those of the author and do not necessarily represent the official position or policies of the U.S. Department of Justice." The current edition of the DOJ Grants Financial Guide provides guidance on allowable printing and publication activities.

60. With respect to this award, federal funds may not be used to pay cash compensation (salary plus bonuses) to any employee of the award recipient at a rate that exceeds 110% of the maximum annual salary payable to a member of the federal government's Senior Executive Service (SES) at an agency with a Certified SES Performance Appraisal System for that year. (An award recipient may compensate an employee at a higher rate, provided the amount in excess of this compensation limitation is paid with non-federal funds.)

This limitation on compensation rates allowable under this award may be waived on an individual basis at the discretion of the OJP official indicated in the program announcement under which this award is made.

AB



61. Recipient integrity and performance matters: Requirement to report information on certain civil, criminal, and administrative proceedings to SAM and FAPIIS

The recipient and sub recipient must comply with any and all applicable requirements regarding reporting of information on civil, criminal, and administrative proceedings connected with (or connected to the performance of) either this OJP award or any other grant, cooperative agreement, or procurement contract from the federal government. Under certain circumstances, recipients of OJP awards are required to report information about such proceedings, through the federal System for Award Management (known as "SAM"), to the designated federal integrity and performance system (currently, "FAPIIS").

The details of recipient obligations regarding the required reporting (and updating) of information on certain civil, criminal, and administrative proceedings to the federal designated integrity and performance system (currently, "FAPIIS") within SAM are posted on the OJP web site at <https://ojp.gov/funding/FAPIIS.htm> (Award condition: Recipient Integrity and Performance Matters, including Recipient Reporting to FAPIIS), and are incorporated by reference here.

62. The recipient and sub recipient agree to comply with OJP grant monitoring guidelines, protocols, and procedures, and to cooperate with BJA and OCFO on all grant monitoring requests, including requests related to desk reviews, enhanced programmatic desk reviews, and/or site visits. The recipient agrees to provide to BJA and OCFO all documentation necessary to complete monitoring tasks, including documentation related to any sub awards made under this award. Further, the recipient agrees to abide by reasonable deadlines set by BJA and OCFO for providing the requested documents. Failure to cooperate with BJA's/OCFO's grant monitoring activities may result in sanctions affecting the recipient's DOJ awards, including, but not limited to: withholdings and/or other restrictions on the recipient's access to grant funds; referral to the Office of the Inspector General for audit review; designation of the recipient as a DOJ High Risk grantee; or termination of an award(s).

63. Recipient understands and agrees that it must submit quarterly Federal Financial Reports (SF-425) and semi-annual performance reports through GMS (<https://grants.ojp.usdoj.gov>), and that it must submit quarterly performance metrics reports through BJA's Performance Measurement Tool (PMT) website (<https://bjapmt.ojp.gov/>). For more detailed information on reporting and other requirements, refer to BJA's website. Failure to submit required reports by established deadlines may result in the freezing of grant funds and High Risk designation.

64. The recipient may not obligate, expend, or draw down any award funds for indirect costs, unless and until either - (1) the recipient submits to OJP a current, federally-approved indirect cost rate agreement, or (2) the recipient determines that it is eligible under the Part 200 Uniform Requirements to use the "de minimis" indirect cost rate described in 2 C.F.R. 200.414(f), and advises OJP in writing of both its eligibility and its election.

65. The sub-recipient understands and acknowledges that it cannot use any federal funds, either directly or indirectly, in support of any contract or sub award to either the Association of Community Organizations for Reform Now (ACORN) or its subsidiaries, without the express prior written approval of OJP.

66. To the fullest extent permitted by law, each party shall forever indemnify, defend, and hold harmless the other party, its officers, directors, employees, representatives, agents, members and affiliates and each of its or their heirs, personal representatives, successors, and assigns, from and against any and every claim, demand, liability, loss, damage, action, debt, judgment, execution, cost, and expense (including reasonable attorney fees and court costs), of whatever kind or nature, which may be asserted against or suffered or incurred by the foregoing indemnities, or any of them, and which arise, directly or indirectly, either in law or in equity, as a result of any misrepresentation or breach of any warranty, covenant, obligation, or term by the indemnifying party hereunder, or by reason of any act or omission of the indemnifying party, its officers, employees, subcontractors, sub recipients, representatives or agents in the performance of the work.

**Comprehensive Opioid, Stimulant, and Substance Abuse Site-based Program (COSSAP) Grant - Specific Terms and Conditions**

67. Sub-recipient agrees to serve the jurisdictions included in their approved budget and scope of work.
68. Sub-recipient agrees to adhere to the allowable usage categories; 1) law enforcement and other first responder diversion programs, 2) naloxone for law enforcement and other first responders, and 3) identifiable and accessible take-back programs for unused controlled substances found in the home and used by hospitals and long-term care facilities.
69. In addition to the approved scope of work activities outlined in the allowable usage categories, sub-grantee will continue to actively and collaboratively engage on the proposed initiative with the existing workgroup, and assist in building the workgroup throughout the program period of performance .
70. Sub-recipient agrees to plan to respond to requests for data and information from the Bureau of Justice Assistance (BJA) designated researcher who may conduct site-specific visits or cross-site visits to conduct and evaluation of the MOST/FASTT.
71. Sub-recipient agrees to attend/participate in monthly calls with the Bureau of Justice Assistance (BJA), Institute for Intergovernmental Research (IIR), and partners. Additionally, the sub-recipient agrees to submit quarterly Performance Measurement reports by the 15<sup>th</sup> of the month after the quarter to [AGgrants@ag.nv.gov](mailto:AGgrants@ag.nv.gov).
72. During the period of this sub-award, confidential material may be disclosed between the parties to permit agreed-upon services to be performed. Such material will be identified at the time it is provided to the other party. Each party will advise and require all assigned employees, agents and consultants to treat such material as confidential and will not disclose such information or work products to any person, organization or corporation. At any time during this sub award, the Institute for Intergovernmental Research (IIR) may require a separate supplemental nondisclosure agreement to be executed detailing any applicable additional obligations.
73. Information sharing projects funded under this award must comply with DOJ's Global Justice Information Sharing Initiative (Global) guidelines. The sub-recipient must conform to the Global Standards Package (GSP) and all constituent elements, where applicable, as described at [https://it.ojp.gov/gsp\\_grantondition](https://it.ojp.gov/gsp_grantondition). The sub-recipient must document planned approaches to information sharing and describe compliance with the GSP and appropriate privacy policy that protects shared information or provide detailed justification for why an alternative approach is recommended.
74. Sub-recipient and sub subrecipient agree to take reasonable steps to provide meaningful access to the project and activities funded under this Award for persons with limited English proficiency pursuant to information located at <http://www.lep.gov> .
75. All travel reimbursements must conform to the limits established by the U.S. General Service Administration as published at <http://www.gsa.gov>. Authorized travel will be reimbursed in accordance with the NVOAG travel policy.
76. To avoid duplicating existing networks or IT systems in any initiatives funded by BJA for law enforcement information sharing systems which involve interstate connectivity between jurisdictions, such systems shall employ, to the extent possible, existing networks as the communication backbone to achieve interstate connectivity, unless the recipient can demonstrate to the satisfaction of BJA that this requirement would not be cost effective or would impair the functionality of an existing or proposed IT system.
77. Sub-recipient/sub-grantee agrees to submit an executed copy of the Statement of Sub-grant Audit Arrangements with the executed award documents.
78. When applicable, sub-recipient/sub-grantee agrees to provide NVOAG with an electronic or hard copy of their most recent agency audit and annual reports within seven (7) days of receipt of same, but no later than June 30, 2022.





79. Sub-recipient/sub-grantee agrees to complete the Office for Civil Rights (OCR) training no later than September 30, 2022. The link for this training is <http://ojp.gov/about/ocr/assistance.htm>.

All recipients and sub-recipients of federal funds are prohibited from discriminating in services and employment because of race, color, national origin, religion, disability, sex, and age. For a complete review of these civil rights laws, see <https://ojp.gov/funding/Explore/LegalOverview/CivilRightsRequirements.htm>.

80. Sub-recipient/sub-grantee agrees to have and keep all applicable liability coverages current.

81. Sub-recipient/sub-grantee must have policies and procedures in place to adequately respond to and resolve complaints from those they serve and those they employ, including "whistle-blower" complaints. More information may be found at <https://www.ojp.gov/program/civil-rights/overview>.

82. Sub-recipient must have policy for making determinations of suitability before certain individuals may interact with participating minors. This requirement applies regardless of an individual's employment status. Details of this requirement are posted on the OJP web site at <https://ojp.gov/funding/Explore/Interact-Minors.htm> (Award Condition: Determination of suitability requires, in advance, for certain individuals who may interact with participating minors), and are incorporated by reference here.

83. The recipient must ensure that, as part of the hiring process for any position within the United States that is or will be funded (in whole or in part) with award funds, the recipient (or any subrecipient) properly verifies the employment eligibility of the individual who is being hired, consistent with the provisions of 8 U.S.C. § 1324a(a)(1) and (2). The details of the recipient's obligations under this condition are posted on the OVW website at <https://www.justice.gov/ovw/award-conditions> (Award Condition: Employment eligibility verification for hiring under award) and are incorporated by reference here.

Restrictions and certifications regarding non-disclosure agreements and related matters. No recipient or sub-recipient under this award, or entity that receives a contract or subcontract with any funds under this award, may require any employee or contractor to sign an internal confidentiality agreement or statement that prohibits or otherwise restricts, or purports to prohibit or restrict, the reporting (in accordance with law) of waste, fraud, or abuse to an investigative or law enforcement representative of a federal department or agency authorized to receive such information.

The foregoing is not intended, and shall not be understood by the agency making this award, to contravene requirements applicable to Standard Form 312 (which relates to classified information), Form 4414 (which relates to sensitive compartmented information), or any other form issued by a federal department or agency governing the nondisclosure of classified information.

1. In accepting this award, the recipient
  - a. Represents that it neither requires nor has required internal confidentiality agreements or statements from employees or contractors that currently prohibit or otherwise currently restrict (or purport to prohibit or restrict) employees or contractors from reporting waste, fraud, or abuse as described above; and
  - b. Certifies that, if it hears or is notified that it is or has been requiring its employees or contractors to execute agreements or statements that prohibit or otherwise restrict (or purport to prohibit or restrict), reporting of waste, fraud, or abuse as described above, it will immediately stop any further obligations of award funds, will provide prompt written notification to the agency making this award, and will resume (or permit resumption of) such obligations only if expressly authorized to do so by that agency.
2. If the recipient does or is authorized to make subawards or contracts under this award –
  - a. It represents that –
    - i. It has determined that no other entity that the recipient's application proposes may or will receive award funds (whether through a subaward, contract, or subcontract) either requires or has required internal confidentiality agreements or statements from employees or contractors that currently prohibit or otherwise currently restrict (or purport to prohibit or

restrict) employees or contractors from reporting waste, fraud, or abuse as described above;  
and

- ii. It has made appropriate inquiry, or otherwise has an adequate factual basis, to support this representation; and
- b. It certifies that, if it learns or is notified that any subrecipient, contractor, or subcontractor entity that receives funds under this award is or has been requiring its employees or contractors to execute agreements or statements that prohibit or otherwise restrict (or purport to prohibit or restrict), reporting of waste, fraud, or abuse as described above, it will immediately stop any further obligations of award funds to or by that entity, will provide prompt written notification to the agency making this award, and will assume (or permit resumption of) such obligations only if expressly authorized to do so by that agency.

84. Sub-recipient must comply with all confidentiality requirements of 34 U.S.C. 10231 and 28 C.F.R. Part 22 that are applicable to collection, use, and revelation of data information. The subrecipient further agrees, as a condition of sub-award approval, to submit a Privacy Certificate that is in accord with requirements of 28 C.F.R. Part 22 and, in particular, 28 C.F.R. 22.23 to NV OAG.

85. Sub-recipient/sub-grantee agrees to monitoring conducted by the OAG, whether it be through site visits, desk reviews, monthly meetings, and/or quarterly meetings

86. If the sub-recipient/sub-grantee has/will have lower tier sub-recipients, the sub-recipient/sub-grantee will monitor lower tier sub-recipients for compliance with this award.

87. Sub-recipients must use Overdose Detection Mapping Application Program (ODMAP) for suspected overdose data trends for the subrecipients area of responsibility to target outreach and harm reduction activities such as distribution of naloxone. An appropriate point of contact must maintain access and can coordinate with the OAG Substance Abuse/Law Enforcement Coordinator for training and access no later than 60 days after executing sub-award. The OAG will provide training on the use of ODMAP to the sub-recipients on how to produce reports that highlight areas of higher suspected overdoses. ODMAP data trend reports must be referenced in quarterly reporting that highlight which areas were targeted for outreach and harm reduction activities.



## STAFF REPORT

**Report To:** Board of Supervisors **Meeting Date:** March 2, 2023

**Staff Contact:** Jason D. Woodbury, District Attorney

**Agenda Title:** For Possible Action: Discussion and possible action regarding a proposed settlement of claims by the State of Nevada and its political subdivisions, including Carson City, against Walmart Inc. concerning opioid-related claims and the execution of a proposed "Subdivision Participation Form" to be included in the written settlement agreement which will result in Carson City receiving approximately \$328,343.01 in accordance with the terms of the settlement agreement and the One Nevada Agreement previously agreed upon among the State of Nevada and participating political subdivisions. (Jason D. Woodbury, jwoodbury@carson.org)

**Staff Summary:** The State of Nevada and the law firm of Eglet Adams have negotiated terms of a proposed settlement with Walmart to resolve opioid-related claims by the State of Nevada and its political subdivisions which are parties to the One Nevada Agreement. Under the terms of the proposed settlement agreement, Carson City would agree to release and forever discharge its "Released Claims," as defined in the settlement agreement, in exchange for Walmart's payment of \$32,231,037.17 to the State of Nevada to be allocated among the State and participating political subdivisions in accordance with the terms of the One Nevada Agreement. Carson City's net allocation of the Walmart settlement funds is presently estimated to be \$328,343.01. Staff recommends approval of the proposed settlement.

**Agenda Action:** Formal Action / Motion **Time Requested:** 15 Minutes

---

### **Proposed Motion**

I move to approve the settlement as presented and to authorize the Mayor to execute the documents necessary to memorialize Carson City's participation in the settlement.

### **Board's Strategic Goal**

Quality of Life

### **Previous Action**

June 16, 2022 (Item 11A) - the Board of Supervisors ("Board") approved Amendment No. 2 to the One Nevada Agreement authorizing the State of Nevada to receive monetary settlements and distribute them in the manner established by the One Nevada Agreement.

February 3, 2022 (Item 12B) - the Board approved Carson City's participation in settlement of claims by the State of Nevada and Local Governments against three opioid distributors and Johnson & Johnson for the total gross sum of \$285,188,201.67 to be allocated among the State and Local Governments in accordance with the One Nevada Agreement and an amendment to the One Nevada Agreement reducing the contingency fee agreement applicable to the two settlements from 25% to 15%.

August 5, 2021 (Item 14A) - the Board approved Carson City's participation in the One Nevada Agreement, whereby the State and its political subdivisions agreed to consolidate efforts in the prosecution of claims against parties involved in the manufacture, distribution, and dispensing of opioids.

May 3, 2018 (Item 18A) - the Board approved a Contingency Fee Agreement with the Eglet Prince (now Eglet Adams) law firm for purposes of seeking recovery of monetary damages and injunctive relief to compensate Carson City for the substantial negative impact opioids have actually and proximately caused to Carson City.

**Background/Issues & Analysis**

The proposed agreement would settle all of Carson City's opioid-related claims against Walmart. In exchange for a release of all opioid-related claims against Walmart, Walmart would provide funds to the State of Nevada in the amount of approximately \$32,231,037.17. The State of Nevada will access the settlement funds and allocate them among the parties participating in the One Nevada Agreement pursuant to the terms of the proposed settlement agreement and the One Nevada Agreement. Carson City's allocation of the settlement funds is presently estimated to be \$328,343.01. None of the settlement amount above described will be allocated to attorneys' fees or to the costs incurred in negotiating the settlement. Rather, attorneys' fees and costs will be allocated from a separate fund pursuant to the terms of the proposed agreement. The proposed settlement would not affect Carson City's claims against other parties involved in the manufacture, distribution or dispensing of opioids.

**Applicable Statute, Code, Policy, Rule or Regulation**

NRS Chapter 244; art. 2 of the Carson City Charter

**Financial Information**

**Is there a fiscal impact?** Yes

**If yes, account name/number:** General Fund - 1011081-463040 Opioid Settlement

**Is it currently budgeted?** No

**Explanation of Fiscal Impact:** Carson City's allocation of the settlement funds is presently estimated to be \$328,343.01.

**Alternatives**

Do not approve Carson City's participation in the proposed settlement and/or provide alternative direction.

**Attachments:**

[Walmart Settlement Agreement \(2022.12.02\)\\_FINAL.pdf](#)

[Walmart Settlement Participation Form - Exhibit K.pdf](#)

[Opioid Allocation Disbursement - Walmart \(estimated\).pdf](#)

**Board Action Taken:**

Motion: _____	1) _____	Aye/Nay
	2) _____	_____
		_____
		_____
		_____

\_\_\_\_\_  
(Vote Recorded By)





# **WALMART SETTLEMENT** **AGREEMENT**

**TABLE OF CONTENTS**

	<b>Page</b>
I. Definitions.....	2
II. Participation by States and Subdivisions; Effectiveness of Agreement .....	14
III. Injunctive Relief.....	16
IV. Settlement Payments.....	16
V. Allocation and Use of Settlement Payments.....	25
VI. Enforcement.....	32
VII. Participation by Subdivisions.....	37
VIII. Additional Remediation.....	39
IX. Plaintiffs’ Attorneys’ Fees and Costs.....	39
X. Release .....	40
XI. Later Litigating Subdivisions; Non-Settling States .....	44
XII. Miscellaneous.....	45
EXHIBIT A - Alleged Harm.....	A-1
EXHIBIT B - Enforcement Committee Organization Bylaws .....	B-1
EXHIBIT C - Litigating Subdivisions List.....	C-1
EXHIBIT D - [Intentionally Omitted] .....	D-1
EXHIBIT E - List of Opioid Remediation Uses.....	E-1
EXHIBIT F - List of States and Overall Allocation Percentages .....	F-1
EXHIBIT G - Subdivisions Eligible to Receive Direct Allocations from the Subdivision Fund and Subdivision Fund Allocation Percentages .....	G-1
EXHIBIT H - [Intentionally Omitted] .....	H-1
EXHIBIT I - Primary Subdivisions .....	I-1
EXHIBIT J - Illustrative List of Released Entities .....	J-1

EXHIBIT K - Subdivision Settlement Participation Form ..... K-1

EXHIBIT L - Settlement Fund Administrator .....L-1

EXHIBIT M - Maximum Payment Amounts .....M-1

EXHIBIT N - Additional Remediation Amount Allocation Percentages..... N-1

EXHIBIT O - Adoption of a State-Subdivision Agreement..... O-1

EXHIBIT P - Injunctive Relief..... P-1

EXHIBIT Q - [Intentionally Omitted] ..... Q-1

EXHIBIT R - Agreement on Attorneys’ Fees, Costs, and Expenses.....R-1

EXHIBIT S - Agreement on the State Outside Counsel Fee Fund.....S-1

EXHIBIT T - Agreement on the State Cost Fund.....T-1

EXHIBIT U - IRS Form 1098-F..... U-1

EXHIBIT V - Walmart Settlement Agreement Sign-on Form ..... V-1

EXHIBIT W - Non-Litigating Threshold Subdivisions List ..... W-1

EXHIBIT X - Governor's Release of Opioid-Related Claims..... X-1

## **WALMART SETTLEMENT AGREEMENT**

This Settlement Agreement, dated as of November 14, 2022 (the “*Agreement*”), sets forth the terms of settlement between and among the Settling States, Walmart, and the Participating Subdivisions (as those terms are defined below). Upon satisfaction of the conditions set forth in Section II, this Agreement will be binding on all Settling States, Participating Subdivisions, and Walmart. This Agreement will then be submitted for entry as part of Consent Judgments in the respective courts of each of the Settling States, pursuant to the terms set forth in Section II.

WHEREAS, certain States and Subdivisions have filed or could file Actions in various forums against Walmart raising Claims or allegations concerning, related to, based upon, or in connection with the Alleged Harms and/or the Covered Conduct;

WHEREAS, Walmart (i) denies each and all of the Claims and allegations of wrongdoing made by the States and Litigating Subdivisions in each of the Actions and maintains that it has meritorious defenses; (ii) denies all assertions of wrongdoing or liability against Walmart arising out of any of the conduct, statements, acts or omissions alleged, or that could have been alleged, in the Actions already brought or that could be brought by any State or Subdivision related to the Covered Conduct and/or Alleged Harms and contends that the factual allegations made in the current Actions relating to Walmart are false and materially inaccurate; (iii) denies that any State, Subdivision, or resident thereof, was harmed by any conduct of Walmart; (iv) denies liability, denies any wrongdoing, and denies it violated any federal or state statute or common law; and (v) maintains that Walmart would be able to successfully defend against the Claims and allegations at trial, that the facts do not support the allegations, that Walmart engaged in no misconduct or unlawful activity, and that Walmart caused no harm to any State, Subdivisions, or resident thereof;

WHEREAS, the Parties have investigated the facts and analyzed the relevant legal issues regarding the Claims and defenses that have been or could have been asserted in the Actions;

WHEREAS, objective data metrics reported in the federal ARCOS database demonstrate that on a national basis Walmart dispensed on average materially fewer and less potent opioids per store than other major chain pharmacies and many independent pharmacies nationwide, and Walmart’s share of opioids distributed and dispensed nationwide was substantially lower than other major chain pharmacies;

WHEREAS, Walmart has implemented policies, procedures, and controls relating to the dispensing of prescription opioid medications and other controlled substances, including pharmacist training and empowerment programs, company-wide limitations on strength and duration of acute opioid prescriptions, and opioid data analytics, which Walmart uses to identify and investigate potentially problematic prescribing practices;

WHEREAS, the Parties have determined that it is preferable to resolve any claims the States and Subdivisions may have through a cooperative and mutually beneficial settlement that provides funding to remediate Alleged Harms;

WHEREAS, the Parties have each considered the costs, delays and uncertainty associated with the prosecution and defense of an action and the continued prosecution and defense of the Actions;

WHEREAS, the Parties believe the settlement set forth herein avoids the uncertainties of litigation and assures that the benefits reflected herein are obtained;

WHEREAS, the States have concluded that the terms of the settlement are fair, reasonable and adequate and in the best interest of the States and all Subdivisions and citizens and residents of the States;

WHEREAS, the Parties have agreed to the terms herein for the sole purpose of settlement, and nothing herein may be taken as or construed to be an admission or concession of any violation of law, rule, or regulation, or of any other matter of fact or law, or of any liability or wrongdoing or lack thereof;

WHEREAS no part of this Agreement, including its statements and commitments, shall constitute evidence of any liability, fault, or wrongdoing, or of any lack thereof;

WHEREAS, unless the contrary is expressly stated, this Agreement is not intended for use by any Party or any third party for any purpose not expressly stated herein, including submission to any court for any purpose other than Court approvals associated with this Agreement;

NOW, THEREFORE, IT IS HEREBY AGREED by and between the States, Participating Subdivisions, and Walmart, by and through their respective counsel, as follows:

## **I. Definitions**

For all sections of this Agreement except Exhibit E and Exhibit P, the following definitions apply:

A. “*Remediation Accounts Fund*” means the component of the Settlement Fund described in Section V.E.

B. “*Actions*” means any lawsuit by a Settling State or Participating Subdivision asserting any Released Claim against one or more Released Entities.

C. “*Additional Remediation Amount*” means the amount available to the Settling States totaling up to \$16,006,471.88.

D. “*Advisory Committee*” has the meaning set forth in Section V.E.2.d.

E. “*Agreement*” has the definition set forth in the preamble, including all exhibits.

F. “*Alleged Harms*” means the alleged past, present, and future financial and societal harms and related expenditures arising out of the alleged misuse and abuse of Products, non-exclusive examples of which are described in the documents listed on Exhibit A, including those expenditures that have allegedly arisen as a result of the physical and bodily injuries sustained by individuals suffering from opioid-related addiction, abuse, death, and other related diseases and disorders, and that have allegedly been caused by Walmart.

G. “*Allocation Statute*” means a state law that governs allocation, distribution, and/or use of some or all of the Settlement Fund amounts allocated to that State and/or its Subdivisions. In addition to modifying the allocation as set forth in Section V.D.2, an Allocation Statute may, without limitation, contain a Statutory Trust, further restrict expenditures of funds, form an advisory committee, establish oversight and reporting requirements, or address other default provisions and other matters related to the funds. An Allocation Statute is not required to address all three (3) types of funds comprising the Settlement Fund or all default provisions.

H. “*Appropriate Official*” has the meaning set forth in Section XII.F.3.

I. “*Base Payment*” has the meaning set forth in Section IV.D.

J. “*Bankruptcy Code*” means Title 11 of the United States Code, 11 U.S.C. §§ 101, *et seq.*

K. “*Bar*” means either: (1) a law barring Subdivisions in a State from maintaining Released Claims against Released Entities (either through a direct bar or through a grant of authority to release claims and the exercise of such authority in full); or (2) a ruling by the highest court of the State (or, in a State with a single intermediate court of appeals, the intermediate court of appeals when not subject to further review by the highest court of the State) setting forth the general principle that Subdivisions in the State may not maintain any Released Claims against Released Entities, whether on the ground of this Agreement (or the release in it) or otherwise. For the avoidance of doubt, a law or ruling that is conditioned or predicated upon payment by a Released Entity (apart from payments made by Walmart under this Agreement) shall not constitute a Bar.

L. “*Case-Specific Resolution*” means either: (1) a law barring the Subdivision at issue from maintaining any Released Claims against any Released Entities (either through a direct bar or through a grant of authority to release claims and the exercise of such authority in full); or (2) a ruling by a court of competent jurisdiction over the Subdivision at issue that the Subdivision may not maintain any Released Claims at issue against any Released Entities, whether on the ground of this Agreement (or the release in it) or otherwise. For the avoidance of doubt, a law or ruling that is conditioned or predicated upon payment by a Released Entity (apart from payments made by Walmart under this Agreement) shall not constitute a Case-Specific Resolution.

M. “*Claim*” means any past, present or future cause of action, claim for relief, cross-claim or counterclaim, theory of liability, demand, derivative claim, request, assessment, charge, covenant, damage, debt, lien, loss, penalty, judgment, right, obligation, dispute, suit, contract, controversy, agreement, *parens patriae* claim, promise, performance, warranty, omission, or grievance of any nature whatsoever, whether legal, equitable, statutory, regulatory or administrative, whether arising under federal, state or local common law, statute, regulation, guidance, ordinance or principles of equity, whether filed or unfiled, whether asserted or unasserted, whether known or unknown, whether accrued or unaccrued, whether foreseen, unforeseen or unforeseeable, whether discovered or undiscovered, whether suspected or unsuspected, whether fixed or contingent, and whether existing or hereafter arising, in all such cases, including but not limited to any request for declaratory, injunctive, or equitable relief, compensatory, punitive, or statutory damages, absolute liability, strict liability, restitution,

abatement, subrogation, contribution, indemnity, apportionment, disgorgement, reimbursement, attorney fees, expert fees, consultant fees, fines, penalties, expenses, costs or any other legal, equitable, civil, administrative, or regulatory remedy whatsoever.

N. “*Claim-Over*” means a Claim asserted by a Non-Released Entity against a Released Entity on the basis of contribution, indemnity, or other claim-over on any theory relating to a Non-Party Covered Conduct Claim asserted by a Releasor.

O. “*Consent Judgment*” means a state-specific consent judgment in a form to be agreed by the Settling States and Walmart prior to the State Participation Date that, among other things, (1) approves this Agreement and (2) provides for the release set forth in Section X.A, including the dismissal with prejudice of any Released Claims that the Settling State has brought against Released Entities.

P. “*Covered Conduct*” means any actual or alleged act, failure to act, negligence, statement, error, omission, breach of any duty, conduct, event, transaction, agreement, misstatement, misleading statement or other activity of any kind whatsoever from the beginning of time through the Threshold Subdivision Participation Date (and any past, present, or future consequence of any such act, failure to act, negligence, statement, error, omission, breach of duty, conduct, event, transaction, agreement, misstatement, misleading statement or other activity) relating in any way to (a) the distribution, dispensing, delivery, monitoring, reporting, supply, sale, prescribing, physical security, warehousing, coverage, purchases, reimbursement, discovery, development, manufacture, packaging, repackaging, marketing, promotion, advertising, labeling, recall, withdrawal, or use or abuse of any Product; orders, prescriptions, formularies, guidelines, payments or rebates for any Product; policies, practices and/or operating procedures, insurance, claim or benefit administration, claim adjudication, plan design, data and sales thereof, relating to any Product; and any system, plan, policy or advocacy relating to any Product, including, but not limited to, any unbranded promotion, marketing, programs, or campaigns relating to any Product; (b) the characteristics, properties, risks, or benefits of any Product; (c) the reporting, disclosure, nonreporting or non-disclosure to federal, state or other regulators of orders or prescriptions, related to any Product; (d) the purchasing, selling, acquiring, disposing of, importing, exporting, handling, processing, packaging, supplying, distributing, or converting of any Product; or (e) controls against diversion, corresponding responsibility, and suspicious order monitoring; *provided, however*, that as to any Claim that a Releasor has brought or could bring, Covered Conduct does not include noncompliance with statutory or administrative supply security standards concerning cleanliness of facilities or stopping counterfeit products, so long as such standards apply to the storage and distribution of both controlled and non-controlled pharmaceuticals.

Q. “*Deposit Date*” means fifteen (15) days after the Effective Date.

R. “*Designated State*” means New York.

S. “*Effective Date*” has the meaning set forth in Section II.C.

T. “*Eligible State*” means the states, commonwealths, and territories of the United States of America, as well as the District of Columbia and Puerto Rico, but excluding New Mexico,



West Virginia, and any Separately Settling State. The use of non-capitalized “state” to describe something (e.g., “state court”) shall also be read to include parallel entities in commonwealths, territories, and the District of Columbia (e.g., “territorial court”).

U. “*Enforcement Committee*” means a committee consisting of certain representatives of the Settling States and of the Participating Subdivisions selected and operating pursuant to the organizational bylaws set forth at Exhibit B. Notice pursuant to Section XII.Q shall be provided when there are changes in membership or contact information.

V. “*Final Order*” means an order or judgment of a court of competent jurisdiction with respect to the applicable subject matter (1) which has not been reversed or superseded by a modified or amended order, is not currently stayed, and as to which any right to appeal or seek *certiorari*, review, reargument, stay, or rehearing has expired, and as to which no appeal or petition for *certiorari*, review, reargument, stay, or rehearing is pending, or (2) as to which an appeal has been taken or petition for *certiorari*, review, reargument, stay, or rehearing has been filed and (a) such appeal or petition for *certiorari*, review, reargument, stay, or rehearing has been resolved by the highest court to which the order or judgment was appealed or from which *certiorari*, review, reargument, stay, or rehearing was sought, or (b) the time to appeal further or seek *certiorari*, review, reargument, stay, or rehearing has expired and no such further appeal or petition for *certiorari*, review, reargument, stay, or rehearing is pending.

W. “*First Subdivision Participation Date*” has the meaning set forth in Section IV.C.3.a.

X. “*Global Settlement Remediation Amount*” means the remediation and abatement amount of up to \$2,393,794,118.64.

Y. “*Global Settlement Amount*” means the sum of (a) the Remediation Payment, (b) the Additional Remediation Amount, and (c) any attorneys’ fees and costs set forth in Exhibit R, Exhibit S and Exhibit T.

Z. “*Implementation Administrator*” means the vendor agreed to by Walmart and the Enforcement Committee and retained by Walmart to provide notice pursuant to Section VII.A and to manage the initial joinder period for Subdivisions, including the issuance and receipt of Subdivision Participation Forms.

AA. “*Incentive BC Subdivisions*” has the meaning set forth in Section IV.E.2.a.

BB. “*Incentive Payment A*” means the incentive payment described in Section IV.E.1.

CC. “*Incentive Payment BC*” means the incentive payment described in Section IV.E.2.

DD. “*Incentive Payment D*” means the incentive payment described in Section IV.E.3.

EE. “*Injunctive Relief Terms*” means the terms described in Section III and set forth in Exhibit P.

FF. “*Later Litigating Subdivision*” means a Subdivision (or Subdivision official asserting the right of or for the Subdivision to recover for Alleged Harms to the Subdivision and/or the people thereof) that: (1) first files a lawsuit bringing a Released Claim against a Released Entity after the Threshold Subdivision Participation Date; or (2) adds a Released Claim against a Released Entity after the Threshold Subdivision Participation Date to a lawsuit brought before the Threshold Subdivision Participation Date that, prior to the Threshold Subdivision Participation Date, did not include any Released Claims against a Released Entity; or (3) (a) was a Litigating Subdivision whose Released Claims against Released Entities were resolved by a legislative Bar or legislative Case-Specific Resolution as of the Threshold Subdivision Participation Date, (b) such legislative Bar or legislative Case-Specific Resolution is subject to a Revocation Event after the Threshold Subdivision Participation Date, and (c) the earlier of the date of completion of opening statements in a trial in an action brought by a Subdivision in that Settling State that includes a Released Claim against a Released Entity or one hundred eighty (180) days from the Revocation Event passes without a Bar or Case-Specific Resolution being implemented as to that Litigating Subdivision or the Litigating Subdivision’s Released Claims being dismissed; or (4) (a) was a Litigating Subdivision whose Released Claims against Released Entities were resolved by a judicial Bar or judicial Case-Specific Resolution as of the Threshold Subdivision Participation Date, (b) such judicial Bar or judicial Case-Specific Resolution is subject to a Revocation Event after the Threshold Subdivision Participation Date, and (c) such Litigating Subdivision takes any action in its lawsuit asserting a Released Claim against a Released Entity other than seeking a stay or dismissal.

GG. “*Litigating Subdivisions*” means all Subdivisions that have brought any Released Claim against any Released Entity as of the Threshold Subdivision Participation Date. Attached as Exhibit C is a list of the Litigating Subdivisions in each Eligible State and Separately Settling State. Exhibit C will be updated (including with any corrections) periodically, and a final version of Exhibit C will be attached hereto as of the Threshold Subdivision Participation Date.

HH. “*National Arbitration Panel*” means the panel comprised as described in Section VI.F.3.b.

II. “*National Disputes*” has the meaning set forth in Section VI.F.3.a.

JJ. “*Non-Litigating Subdivision*” means any Subdivision that is neither a Litigating Subdivision nor a Later Litigating Subdivision.

KK. “*Non-Litigating Threshold Subdivision*” means (a) all general-purpose Subdivisions with a population equal to or greater than 30,000 that have not brought a Released Claim against any Released Entity as of the Threshold Subdivision Participation Date and (b) all general-purpose Subdivisions with populations between 10,000 and 30,000 that have not brought Released Claim against any Released Entity but have brought a claim related to opioid products, including any Claims related to the Covered Conduct and/or Alleged Harms, against McKesson, AmerisourceBergen, Cardinal Health, Janssen Pharmaceuticals, or any parents, subsidiaries, divisions, predecessors, successors, and assigns of McKesson, AmerisourceBergen, Cardinal Health, or Janssen Pharmaceuticals. Attached as Exhibit W is a list of the Non-Litigating Threshold Subdivisions in each Eligible State and Separately Settling State. Exhibit W will be

updated (including with any corrections) periodically, and a final version of Exhibit W will be attached hereto as of the Threshold Subdivision Participation Date.

LL. “*Non-Participating Subdivision*” means any Subdivision that is not a Participating Subdivision.

MM. “*Non-Party Covered Conduct Claim*” means a Claim against any Non-Released Entity involving, arising out of, or related to Alleged Harms and/or Covered Conduct (or conduct that would be Covered Conduct if engaged in by a Released Entity).

NN. “*Non-Party Settlement*” means a settlement by any Releasor that settles any Non-Party Covered Conduct Claim and includes a release of any Non-Released Entity.

OO. “*Non-Released Entity*” means an entity that is not a Released Entity.

PP. “*Non-Settling State*” means any Eligible State that is not a Settling State.

QQ. “*Opioid Remediation*” means care, treatment, and other programs and expenditures (including reimbursement for past such programs or expenditures<sup>1</sup> except where this Agreement restricts the use of funds solely to future Opioid Remediation) designed to remediate Alleged Harms, including to (1) address the misuse and abuse of opioid products, (2) treat or mitigate opioid use or related disorders, or (3) mitigate other alleged effects of, including on those injured as a result of, the opioid epidemic. Exhibit E provides a non-exhaustive list of expenditures that qualify as being paid for Opioid Remediation. Qualifying expenditures may include reasonable related administrative expenses.

RR. “*Overall Allocation Percentage*” means a Settling State’s percentage as set forth in Exhibit F.

SS. “*Participating Population Levels*” has the meaning set forth in Section II.B.1.

TT. “*Participating Subdivision*” means any Subdivision in a Settling State that joins the settlement and meets the requirements for becoming a Participating Subdivision under Section VII.B or Section VII.C, as applicable.

UU. “*Parties*” means Walmart and the Settling States (each, a “*Party*”).

VV. “*Payment Year*” means the calendar year during which the applicable Payout Amount is made in accordance with Section IV.B. Payment Year 1 is 2023, Payment Year 2 is 2024 and so forth.

WW. “*Payout Amount*” means the total amount payable to the Settling States by the Settlement Fund Administrator for each Payment Year, as calculated by the Settlement Fund Administrator pursuant to Section IV.B. For the avoidance of doubt, this term does not include amounts paid pursuant to Section VIII and Section IX.

---

<sup>1</sup> Reimbursement includes amounts paid to any governmental entities for past expenditures or programs.

XX. “*Percentage of Incentive BC Subdivision Population*” has the meaning set forth in Section IV.E.2.a.

YY. “*Primary Fire District*” means a fire district that covers a population of 25,000, or 0.20% of an Eligible State’s population if an Eligible State’s population is greater than 18 million. If not easily calculable from state data sources and agreed to between the Eligible State and Walmart, a fire district’s population is calculated by dividing the population of the county or counties a fire district serves by the number of fire districts in the county or counties. “Primary Fire Districts” shall mean fire districts as identified in connection with the implementation of the July 21, 2021 Janssen Settlement Agreement.

ZZ. “*Primary Subdivision*” means any General-Purpose Government (including, but not limited to, a municipality, county, county subdivision, city, town, township, parish, village, borough, gore, or any other entities that provide municipal-type government) with a population over 10,000. Attached as Exhibit I is an agreed list of the Primary Subdivisions in each State.

AAA. “*Prior Litigating Subdivision*” means a Subdivision (or Subdivision official) that brought any Released Claim against any Released Entity prior to the Threshold Subdivision Participation Date and all such Released Claims were separately settled or finally adjudicated prior to the Threshold Subdivision Participation Date; *provided, however*, that if the final adjudication was pursuant to a Bar, such Subdivision shall not be considered a Prior Litigating Subdivision. Notwithstanding the prior sentence, Walmart and the Settling State of the relevant Subdivision may agree in writing that the Subdivision shall not be considered a Prior Litigating Subdivision.

BBB. “*Product*” means any chemical substance, whether used for medicinal or non-medicinal purposes, and whether natural, synthetic, or semi-synthetic, or any finished pharmaceutical product made from or with such substance, that is (1) an opioid or opiate, as well as any product containing any such substance; (2) a benzodiazepine, a muscle relaxer, carisoprodol, zolpidem, or gabapentin; or (3) a combination or “cocktail” of any stimulant or other chemical substance prescribed, sold, bought, or dispensed to be used together that includes opioids or opiates. “Product” shall include, but is not limited to, any substance consisting of or containing buprenorphine, codeine, fentanyl, hydrocodone, hydromorphone, meperidine, methadone, morphine, oxycodone, oxymorphone, tapentadol, tramadol, opium, heroin, carfentanil, diazepam, estazolam, quazepam, alprazolam, clonazepam, oxazepam, flurazepam, triazolam, temazepam, midazolam, carisoprodol, gabapentin, or any variant of these substances or any similar substance. Notwithstanding the foregoing, nothing in this section prohibits a Settling State from taking administrative or regulatory action related to benzodiazepine (including, but not limited to, diazepam, estazolam, quazepam, alprazolam, clonazepam, oxazepam, flurazepam, triazolam, temazepam, and midazolam), a muscle relaxer, carisoprodol, zolpidem, or gabapentin that is wholly independent from the use of such drugs in combination with opioids, provided such action does not seek money (including abatement and/or remediation) for conduct prior to the Effective Date.

CCC. “*Released Claims*” means any and all Claims that directly or indirectly are based on, arise out of, or in any way relate to or concern Covered Conduct and/or Alleged Harms occurring prior to the Threshold Subdivision Participation Date. Without limiting the foregoing, “Released Claims” include any Claims that have been asserted against the Released Entities by

any Settling State or any of its Litigating Subdivisions or Litigating Special Districts in any federal, state or local action or proceeding (whether judicial, arbitral, or administrative) based on, arising out of or relating to, in whole or in part, the Covered Conduct and/or Alleged Harms, or any such Claims that could be or could have been asserted now or in the future in those actions or in any comparable action or proceeding brought by a State, any of its Subdivisions or Special Districts, or any Releasors (whether or not such State, Subdivision, Special District, or Releasor has brought such action or proceeding). Released Claims also include all Claims asserted in any proceeding to be dismissed pursuant to the Agreement, whether or not such claims relate to Covered Conduct and/or Alleged Harms. The Parties intend that “Released Claims” be interpreted broadly. This Agreement does not release Claims by private individuals. It is the intent of the Parties that Claims by private individuals be treated in accordance with applicable law. Released Claims is also used herein to describe Claims brought by a Later Litigating Subdivision or other non-party Subdivision or Special District that would have been Released Claims if they had been brought by a Releasor against a Released Entity.

DDD. “*Released Entities*” means Walmart and (1) all of Walmart’s past and present direct or indirect parents, subsidiaries, divisions, predecessors, successors, and assigns; (2) the past and present direct or indirect subsidiaries, divisions, and joint ventures, of any of the foregoing; (3) all of Walmart’s insurers (solely in their role as insurers with respect to the Released Claims); (4) all of Walmart’s, or of any entity described in subsection (1), past and present joint ventures; and (5) the respective past and present officers, directors, members, shareholders (solely in their capacity as shareholders of the foregoing entities), partners, trustees, and employees of any of the foregoing (for actions that occurred during and related to their work for, or employment with, Walmart). Any person or entity described in subsections (3)-(5) shall be a Released Entity solely in the capacity described in such clause and shall not be a Released Entity with respect to its conduct in any other capacity. For the avoidance of doubt, any joint venture partner of a joint venture in subsection (2) or (4) is not a Released Entity unless such entity independently falls within subsections (1)-(5) above. An illustrative list of Walmart’s present joint ventures, subsidiaries and affiliates and predecessor entities is set forth in Exhibit J. With respect to joint ventures (including predecessor entities), only entities listed on Exhibit J are Released Entities. Current or former Defendants in *In re: National Prescription Opiate Litigation*, No. 1: 17-md-2804 (N.D. Ohio) (“MDL”) (or in other pending litigation asserting a Claim for Covered Conduct, as identified in the “*National Opiate Litigation – Case and Defendant Extract*” provided to Walmart by the Plaintiffs’ Executive Committee on November 12, 2022) not identified in Exhibit J are not considered Released Entities, provided, however, that any Walmart entities that fall within clauses (1)-(5) above against whom Released Claims are brought in the MDL on or after November 14, 2022 shall be considered Released Entities even if not listed on Exhibit J. For the avoidance of doubt, any entity acquired, or joint venture entered into, by Walmart after the Threshold Subdivision Participation Date is not a Released Entity.

EEE. “*Releasors*” means (1) each Settling State; (2) each Participating Subdivision; and (3) without limitation and to the maximum extent of the power of each Settling State’s Attorney General and/or Participating Subdivision to release Claims, (a) the Settling State’s and Participating Subdivision’s departments, agencies, divisions, boards, commissions, Subdivisions, districts, instrumentalities of any kind and attorneys, including its Attorney General, and any person in their official capacity whether elected or appointed to serve any of the foregoing, and any agency, person, or other entity claiming by or through any of the foregoing, (b) any public

entities, public instrumentalities, public educational institutions, unincorporated districts, fire districts, irrigation districts, water districts, law enforcement districts, emergency services districts, school districts, hospital districts and other Special Districts in a Settling State, and (c) any person or entity acting in a *parens patriae*, sovereign, quasi-sovereign, private attorney general, qui tam, taxpayer, or other capacity seeking relief on behalf of or generally applicable to the general public with respect to a Settling State or Subdivision in a Settling State, whether or not any of them participate in the Agreement. The inclusion of a specific reference to a type of entity in this definition shall not be construed as meaning that the entity is not a Subdivision. Each Settling State’s Attorney General represents that he or she has or has obtained (or will obtain no later than the Threshold Subdivision Participation Date) the authority set forth in Section X.G. In addition to being a Releaser as provided herein, a Participating Subdivision shall also provide the Subdivision Participation Agreement referenced in Section VII providing for a release to the fullest extent of the Participating Subdivision’s authority.

FFF. “*Remediation Payment*” has the meaning set forth in Section IV.B.1.<sup>2</sup>

GGG. “*Revocation Event*” means, with respect to a Bar, Settlement Class Resolution, or Case-Specific Resolution, a revocation, rescission, reversal, overruling, or interpretation that in any way limits the effect of such Bar, Settlement Class Resolution, or Case-Specific Resolution on Released Claims, or any other action or event that otherwise deprives the Bar, Settlement Class Resolution, or Case-Specific Resolution of force or effect in any material respect.

HHH. “*Second Subdivision Participation Date*” has the meaning set forth in Section IV.C.3.b.

III. “*Separately Settling State*” means each of Alabama, Florida, and any other Eligible State that, prior to the State Participation Date, enters into a settlement agreement with Walmart that is separate from this Agreement and resolves substantially all Released Claims against Walmart.

JJJ. “*Settlement Class Resolution*” means a class action resolution in a court of competent jurisdiction in a Settling State (that is not successfully removed to federal court) with respect to a class of Subdivisions in that Settling State that (1) conforms with that Settling State’s statutes, case law, and rules of procedure regarding class actions; (2) is approved and entered as an order of a court of competent jurisdiction in that Settling State and such order has become a Final Order; (3) is binding on all Non-Participating Subdivisions in that Settling State (other than opt outs as permitted under the next sentence); (4) provides that all such Non-Participating Subdivisions may not bring any Released Claims against any Released Entities, whether on the ground of this Agreement (or the releases herein) or otherwise; and (5) does not impose any costs

---

<sup>2</sup> The total maximum amount of this settlement is up to \$3,011,242,061, which includes (i) up to \$2,393,794,118.64 in the Remediation Payment; (ii) up to \$297,720,376.93 in Subdivision Attorneys’ Fees, Expenses and Costs; (iii) up to \$48,019,415.63 in the State Outside Counsel Fee Fund, State Cost Fund and Additional Remediation Amount; (iv) a credit of \$215,567,502.95 for Walmart’s settlement with the state of Florida and its subdivisions; (v) a credit of \$48,963,983.74 for Walmart’s settlement with the state of Alabama and its subdivisions; (vi) a credit of \$1,051,663.05 for ineligible subdivisions Lake County and Trumbull County of Ohio; and (vii) a credit of \$6,125,000.00 for Walmart’s settlement with Nassau County and Suffolk County of New York. In no event shall Walmart’s payment obligation under this Agreement exceed the sum of (i)-(iii) above.

or obligations on Walmart other than those provided for in this Agreement, or contain any provision inconsistent with any provision of this Agreement. If applicable state law requires that opt-out rights be afforded to members of the class, a class action resolution otherwise meeting the foregoing requirements shall qualify as a Settlement Class Resolution unless Subdivisions collectively representing more than one percent (1%) of the total population of that Settling State opt out. In seeking certification of any Settlement Class, the applicable Settling State and Participating Subdivisions shall make clear that certification is sought solely for settlement purposes and shall have no applicability beyond approval of the settlement for which certification is sought. Nothing in this Agreement constitutes an admission by any Party that class certification would be appropriate for litigation purposes in any case or for purposes unrelated to this Agreement.

KKK. “*Settlement Fund*” means the interest-bearing fund established pursuant to this Agreement into which the payment under Section IV is made. The Settlement Fund is comprised of the Remediation Accounts Fund, State Fund, and Subdivision Fund.

LLL. “*Settlement Fund Administrator*” means the entity that determines the payments and reversions due under Section IV and Section VIII, including annually determining the Payout Amount and calculating Incentive Payments, administers the Settlement Fund, and distributes amounts into three sub-funds (the Remediation Accounts Fund, State Fund, and Subdivision Fund) pursuant to this Agreement. The duties of the Settlement Fund Administrator shall be governed by this Agreement. Prior to the Threshold Subdivision Participation Date, Walmart and the Enforcement Committee shall agree to selection and removal processes for and the identity of the Settlement Fund Administrator, and a detailed description of the Settlement Fund Administrator’s duties and responsibilities, including a detailed mechanism for paying the Settlement Fund Administrator’s fees and costs, all of which shall be appended to the Agreement as Exhibit L.

MMM. “*Settling State*” means an Eligible State that has entered into this Agreement with Walmart and delivers an executed State Participation Form and executed releases in accordance with Section II.A.

NNN. “*State Fund*” means the component of the Settlement Fund described in Section V.C.

OOO. “*State Participation Form*” means the form attached as Exhibit V.

PPP. “*State Participation Date*” has the meaning set forth in Section II.A.1.

QQQ. “*State Participation Threshold*” has the meaning set forth in Section II.A.1.

RRR. “*State-Subdivision Agreement*” means an agreement that a Settling State reaches with the Subdivisions in that Settling State regarding the allocation, distribution, and/or use of funds allocated to that Settling State and to its Subdivisions. A State-Subdivision Agreement shall be effective if approved pursuant to the provisions of Exhibit O or if adopted by statute. Preexisting agreements addressing funds other than those allocated pursuant to this Agreement shall qualify if the approval requirements of Exhibit O are met. A Settling State and its Subdivisions may revise a State-Subdivision Agreement if approved pursuant to the provisions of Exhibit O, or if such revision is adopted by statute.



SSS. “*Statutory Trust*” means a trust fund established by state law to receive funds allocated to a Settling State’s Remediation Accounts Fund and restrict any expenditures made using funds from such Settling State’s Remediation Accounts Fund to Opioid Remediation, subject to reasonable administrative expenses. A Settling State may give a Statutory Trust authority to allocate one (1) or more of the three (3) types of funds comprising such State’s Settlement Fund, but this is not required.

TTT. “*Sub-Fund(s)*” means the Remediation Accounts Fund, State Fund, and Subdivision Fund, individually or collectively, as applicable.

UUU. “*Subdivision*” means any (1) General-Purpose Government (including, but not limited to, a municipality, county, county subdivision, city, town, township, parish, village, borough, gore, or any other entities that provide municipal-type government), School District, or Special District within a Settling State, and (2) any other subdivision or subdivision official or sub-entity of or located within a Settling State (whether political, geographical or otherwise, whether functioning or non-functioning, regardless of population overlap, and including, but not limited to, nonfunctioning governmental units and public institutions) that has filed a lawsuit that includes a Released Claim against a Released Entity in a direct, *parens patriae*, or any other capacity. “General-Purpose Government,” “School District,” and “Special District” shall correspond to the “five basic types of local governments” recognized by the U.S. Census Bureau and match the 2017 list of Governmental Units.<sup>3</sup> The three (3) General-Purpose Governments are county, municipal, and township governments; the two (2) special purpose governments are School Districts and Special Districts.<sup>4</sup> The terms “Fire District,” “Health District,” “Hospital District,” and “Library District” shall correspond to categories of Special Districts recognized by the U.S. Census Bureau.<sup>5</sup> References to a Settling State’s Subdivisions or to a Subdivision “in,” “of,” or “within” such Settling State include Subdivisions located within the Settling State even if they are not formally or legally a sub-entity of such Settling State; *provided, however*, that a “health district” that includes any of the following words or phrases in its name shall not be considered a Subdivision: mosquito, pest, insect, spray, vector, animal, air quality, air pollution, clean air, coastal water, tuberculosis, and sanitary. Each of Lake and Trumbull Counties of Ohio shall not be considered “Subdivisions” for purposes of this Agreement.

VVV. “*Subdivision Allocation Percentage*” means the portion of a Settling State’s Subdivision Fund set forth in Exhibit G that a Subdivision will receive pursuant to Section V.C or Section V.D if it becomes a Participating Subdivision. The aggregate Subdivision Allocation

---

<sup>3</sup> <https://www.census.gov/data/datasets/2017/econ/gus/public-use-files.html>.

<sup>4</sup> *E.g.*, U.S. Census Bureau, “Technical Documentation: 2017 Public Use Files for State and Local Government Organization” at 7 (noting that “the Census Bureau recognizes five basic types of local governments,” that three of those are “general purpose governments” (county governments, municipal governments, and township governments), and that the other two are “school district and special district governments”), [https://www2.census.gov/programs-surveys/gus/datasets/2017/2017\\_gov\\_org\\_meth\\_tech\\_doc.pdf](https://www2.census.gov/programs-surveys/gus/datasets/2017/2017_gov_org_meth_tech_doc.pdf).

<sup>5</sup> A list of 2017 Government Units provided by the Census Bureau identifies 38,542 Special Districts and categorizes them by “FUNCTION\_NAME.” “Govt\_Units\_2017\_Final” spreadsheet, “Special District” sheet, included in “Independent Governments - list of governments with reference information,” <https://www.census.gov/data/datasets/2017/econ/gus/public-use-files.html>. As used herein, “fire district” corresponds to Special District function name “24 – Local Fire Protection,” “Health District” corresponds to Special District function name “32 – Health,” “Hospital District” corresponds to Special District function name “40 – Hospitals,” and “Library District” corresponds to Special District function name “52 – Libraries.” *See id.*

Percentage of all Subdivisions receiving a Subdivision Allocation Percentage in each State shall equal one hundred percent (100%). Immediately upon the effectiveness of any State-Subdivision Agreement, Allocation Statute, Statutory Trust, or voluntary redistribution allowed by Section V.D.3 (or upon the effectiveness of an amendment to any State-Subdivision Agreement, Allocation Statute, Statutory Trust, or voluntary redistribution allowed by Section V.D.3) that addresses allocation from the Subdivision Fund, whether before or after the Threshold Subdivision Participation Date, Exhibit G will automatically be amended to reflect the allocation from the Subdivision Fund pursuant to the State-Subdivision Agreement, Allocation Statute, Statutory Trust, or voluntary redistribution allowed by Section V.D.3. The Subdivision Allocation Percentages contained in Exhibit G may not change once notice is distributed pursuant to Section VII.A, except upon the effectiveness of any State-Subdivision Agreement, Allocation Statute, Statutory Trust, or voluntary redistribution allowed by Section V.D.3 (or upon the effectiveness of an amendment to any State-Subdivision Agreement, Allocation Statute, Statutory Trust, or voluntary redistribution allowed by Section V.D.3) that addresses allocation from the Subdivision Fund. For the avoidance of doubt, no Subdivision not listed on Exhibit G shall receive an allocation from the Subdivision Fund, and no provision of this Agreement shall be interpreted to create such an entitlement.

WWW. “*Subdivision Fund*” means the component of the Settlement Fund described in Section V.C.

XXX. “*Subdivision Participation Agreement*” means the form of agreement attached as Exhibit K that Participating Subdivisions must execute and return to the Settlement Fund Administrator.

YYY. “*Subdivision Participation Thresholds*” has the meaning set forth in Section II.B.

ZZZ. “*Third Subdivision Participation Date*” has the meaning set forth in Section IV.C.3.c.

AAAA. “*Threshold Motion*” means a motion to dismiss or equivalent dispositive motion made at the outset of litigation under applicable procedure. A Threshold Motion must include as potential grounds for dismissal any applicable Bar or the relevant release by a Settling State or Participating Subdivision provided under this Agreement and, where appropriate under applicable law, any applicable limitations defense.

BBBB. “*Threshold State*” means the District of Columbia, Puerto Rico, and the states of the United States of America, excluding New Mexico and West Virginia.

CCCC. “*Threshold Subdivision Participation Date*” has the meaning set forth in Section II.B.1.

DDDD. “*Total Remediation Amount*” means the aggregate amount paid or incurred by Walmart hereunder other than amounts paid as attorneys’ fees and costs or identified pursuant to Section V.B.2 as being used to pay attorneys’ fees, investigation costs or litigation costs.

EEEE. “*Walmart*” means Walmart Inc.

## II. Participation by States and Subdivisions; Effectiveness of Agreement

### A. *State Participation Threshold.*

1. On November 14, 2022, this Agreement shall be distributed to all Eligible States by the Enforcement Committee. The Eligible States' Attorneys General shall then have until December 15, 2022, or such later date as agreed to in writing by Walmart and the Enforcement Committee prior to December 15, 2022 (the "*State Participation Date*"), to decide whether to become Settling States. Eligible States that determine to become Settling States shall sign a Participation Form, in the form attached as Exhibit V, on or before the State Participation Date and provide it to Walmart and the Enforcement Committee.

2. To meet the State Participation Threshold, more than 85% of all Threshold States, by number of such states (the "*State Participation Threshold*"), must have joined this Agreement as Settling States on or before the State Participation Date. For purposes of calculating the State Participation Threshold, each Separately Settling State that is also a Threshold State shall be included in both the numerator and the denominator for purposes of calculating whether the State Participation Threshold has been satisfied. For the avoidance of doubt, to be satisfied, the State Participation Threshold requires that 43 or more of the 50 Threshold States (a) become Settling States by signing a Participation Form or (b) be included in both the numerator and the denominator for purposes of calculating the State Participation Threshold by virtue of being a Separately Settling State that is also a Threshold State.

3. Within the first business day on or after three (3) calendar days after the State Participation Date, the Enforcement Committee will deliver all signed State Participation Forms to Walmart. If the State Participation Threshold has not been satisfied by the State Participation Date, this Agreement will have no further effect and all releases and other commitments or obligations contained herein or in State Participation Forms will be void, provided, however, that on or after the State Participation Date, Walmart shall have the unilateral right in its sole discretion to extend the State Participation Date or to proceed with the Settlement if the State Participation Threshold has not been satisfied.

### B. *Subdivision Participation Thresholds.*

1. If the State Participation Threshold has been satisfied by the State Participation Date, each of the Settling States will use reasonable efforts to ensure that, by March 31, 2023, or such later date as agreed to in writing by Walmart and the Enforcement Committee prior to March 31, 2023 (the "*Threshold Subdivision Participation Date*"), the Settling States have met the following "*Subdivision Participation Thresholds*": (1) more than 85% of the aggregate population of all Litigating Subdivisions located in the Settling States and Separately Settling States (calculated on an aggregated basis and not a State-by-State basis): (a) have become Participating Subdivisions by executing a Subdivision Participation Agreement, including a release (subject to Section VII.D), in accordance with Section VII.C, (b) are subject to a Bar or Case-Specific Resolution or (c) have joined a settlement between Walmart and a Separately Settling State by executing a participation

form, including a release; and (2) more than 85% of the aggregate population of all Non-Litigating Threshold Subdivisions located in the Settling States and Separately Settling States (calculated on an aggregated basis and not a State-by-State basis): (a) have become Participating Subdivisions by executing a Subdivision Participation Agreement, including a release (subject to Section VII.D), in accordance with Section VII.B, (b) are subject to a Bar or Case-Specific Resolution, or (c) have joined a settlement between Walmart and a Separately Settling State by executing a participation form, including a release (together, the “*Participating Population Levels*”). For the avoidance of doubt, for purposes of calculating the Participating Population Levels for the Subdivision Participation Thresholds, all Litigating Subdivisions and Non-Litigating Threshold Subdivisions located in Separately Settling States shall be included in the respective denominators for purposes of calculating whether the Subdivision Participation Thresholds have been satisfied, and any such Litigating Subdivisions or Non-Litigating Threshold Subdivisions located in Separately Settling States that have joined such separate settlement agreement with Walmart by executing a participation form, including a release, shall be included in the respective numerators for purposes of calculating whether the Subdivision Participation Thresholds have been satisfied.<sup>6</sup>

2. As soon as practicable following the Threshold Subdivision Participation Date, the Settlement Fund Administrator shall calculate the Participating Population Levels and determine whether the Subdivision Participation Thresholds have been met.

a. As soon as practicable following calculation of the Participating Population Levels, the Settlement Fund Administrator shall give notice to Walmart, the Settling States, and the Enforcement Committee of the Participating Population Levels and whether the Subdivision Participation Thresholds have been met.

b. Within ten (10) calendar days of the notice provided by the Settlement Fund Administrator, any Party or the Enforcement Committee may dispute, in writing, the calculation of the Participating Population Levels or the determination of whether the Subdivision Participation Thresholds have been met. Such disputing party must provide a written notice of dispute to the Settlement Fund Administrator, the Enforcement Committee, and Walmart (and the affected Settling State, as applicable) identifying the nature of the dispute.

c. Within ten (10) calendar days of the sending of a written notice of dispute, any affected party may submit a response, in writing, to the Settlement Fund Administrator, the Enforcement Committee, Walmart, and the disputing Party (and the affected Settling State, as applicable) identifying the basis for disagreement with the notice of dispute.

---

<sup>6</sup> For purposes of calculating the Participating Population Levels for the Subdivision Participation Thresholds, the populations of Lake and Trumbull Counties of Ohio and Nassau and Suffolk Counties of New York shall be excluded entirely from both the numerator and denominator of the Subdivision Participation Thresholds of both the Litigating Subdivisions and Non-Litigating Threshold Subdivisions. Nassau and Suffolk Counties of New York also shall be excluded from both the numerator and denominator for purposes of calculating New York’s Incentive BC Subdivision participation.

d. After the time period for a response to be filed has passed, the Settlement Fund Administrator, the Enforcement Committee, Walmart, and the disputing Party (and the affected Settling State, as applicable) shall meet and confer within ten (10) calendar days in an attempt to resolve the dispute. If no resolution is reached, disputes described in this subsection shall be handled in accordance with the terms of Section VI.F.3.

3. If the Subdivision Participation Thresholds are not satisfied by the Threshold Subdivision Participation Date, then any and all releases, commitments or obligations contained herein or in State Participation Forms or Subdivision Participation Agreements shall be void, provided, however, that on or after the Threshold Subdivision Participation Date, Walmart shall have the unilateral right in its sole discretion to extend the Threshold Subdivision Participation Date or to proceed with the Settlement if one or both of the Subdivision Participation Thresholds have not been satisfied.

C. *Conditions to Effectiveness.* If (1) the State Participation Threshold is met by the State Participation Date and (2) the Subdivision Participation Thresholds are met by the Threshold Subdivision Participation Date, then this Agreement will be deemed effective fifteen (15) days after (a) the Threshold Subdivision Participation Date, or (b) such time as the Settlement Fund Administrator has completed the Participating Population Level calculations necessary to determine whether the Subdivision Participation Thresholds have been achieved, the Settlement Fund Administrator has provided notice of such calculations and determinations to the Parties, and any disputes concerning such calculations and determinations have been resolved subject to Section II.B.2.a-d, whichever is later (the “*Effective Date*”). Subject to Walmart’s unilateral right in its sole discretion to extend the State Participation Date and/or the Threshold Subdivision Participation Date if the State Participation Threshold or Subdivision Participation Thresholds have not been met by their respective deadlines, or to proceed with the Settlement if one or more of the State Participation Threshold or Subdivision Participation Thresholds have not been met, as set forth in Sections II.A.3 and II.B.3, if either of the foregoing clauses (1) or (2) is not satisfied by the State Participation Date or the Threshold Subdivision Participation Date, respectively, then any and all commitments or obligations (including any and all releases) contained herein or in any State Participation Form or Subdivision Participation Agreement shall be void.

D. *Consent Judgments.* Promptly after the Effective Date, the Parties will proceed to file the Consent Judgments, and the obligations in the State Participation Forms and Subdivision Participation Agreements will become effective and binding as of the Effective Date.

### **III. Injunctive Relief**

A. *Injunctive Relief.* As part of the Consent Judgments, the Parties agree to the entry of the injunctive relief terms as set forth in Exhibit P.

### **IV. Settlement Payments**

A. *Settlement Fund.* All payments under this Section IV shall be made into the Settlement Fund. The Settlement Fund shall be allocated and used only as specified in Section V.

B. *Payment by Walmart.*

1. Provided the conditions set out in Sections II.A-C are met, within seven (7) calendar days after the Effective Date, the Settlement Fund Administrator shall determine the amount representing the maximum total allocation of opioid remediation and abatement payments for the Settling States (the “*Remediation Payment*”), as calculated by multiplying (a) the total allocation percentages accorded to the Settling States in accordance with Exhibit F by (b) the Global Settlement Remediation Amount.

2. Fifteen (15) calendar days after the Effective Date (the “*Deposit Date*”), Walmart shall deposit the Remediation Payment into the Settlement Fund. The Remediation Payment shall be distributed to the Settling States and/or refunded to Walmart by the Settlement Fund Administrator consistent with the terms of this Agreement. Any interest earned on the Remediation Payment within the Settlement Fund, to the extent not used to pay the fees for the Settlement Fund Administrator, shall become and remain part of the Remediation Payment within the Settlement Fund and be made available for payments on a pro rata basis to the eventual recipients of the funds (either to Walmart in the case of refund or to the applicable Settling State) in accordance with this Agreement.

3. The Settlement Fund Administrator shall determine the Remediation Payment to be deposited by Walmart on the Deposit Date pursuant to Section IV.B.1. The allocation for each Settling State shall be based on the percentages set out in Exhibit F. For the avoidance of doubt, each of West Virginia, New Mexico, Florida, Alabama, and any other Separately Settling State are not eligible to receive payments under this Agreement.

C. *Payments to Settling States and Reversions to Walmart.*

1. *Payments and Refunds.* Subject to the terms of this Section IV.C.1, Settling States shall be eligible to receive payments under this Agreement over a period not to exceed six (6) years. Such payments shall be paid from the Settlement Fund by the Settlement Fund Administrator. Settling States shall be eligible for at most two payments from the Payout Amount in Payment Year 1 and one payment of the Payout Amount for each of Payment Years 2 through 6. Walmart shall be refunded any portion of the Remediation Payment that Settling States failed to earn in a given Payment Year and that Settling States are not able to earn in future years, as well as accrued interest on such amounts, as of the First Subdivision Participation Date and each subsequent anniversary of the First Subdivision Participation Date. The Settlement Fund Administrator will retain sufficient funds in the Settlement Fund in Payment Years 1 and 2 to pay amounts owed to Settling States due to additional Subdivision participation in Payment Years 2 and/or 3.

2. *Procedure for Calculation of Payments and Refunds; Disputes.*

a. Calculation of Payments and Refunds. As soon as practicable following the Threshold Subdivision Participation Date, after determining the Remediation Payment in accordance with Section IV.B, and as soon as practical after each of the First, Second, and Third Subdivision Participation Dates, and as soon as practical after each of the Incentive Payment D Look-Back Dates, the

Settlement Fund Administrator shall calculate (1) the Payout Amount (including the amount of the Settlement Fund to be allocated to the Settlement Fund Administrator in costs and fees pursuant to Section V.C.4); (2) the amount to be received by each Settling State; (3) the amount to be received by the separate types of funds for each Settling State (if applicable); (4) the allocation to be received by each Settling State's Participating Subdivisions listed on Exhibit G; and (5) the amount of any refund due to Walmart, and the Settlement Fund Administrator shall give notice to Walmart, the Settling States, and the Enforcement Committee of each such amount in clauses (1) through (5). If Walmart and the Enforcement Committee inform the Settlement Fund Administrator that they agree on the amounts to be calculated pursuant to clauses (1), (2), and (5) above, the Settlement Fund Administrator shall treat those amounts as the calculated amount. If a Settling State informs the Settlement Fund Administrator that it and its Participating Subdivisions listed on Exhibit G have reached consensus on the amounts to be calculated pursuant to clauses (3) and/or (4) above, the Settlement Fund Administrator shall use those amounts so long as they are consistent with the amount calculated pursuant to clause (2). The Payout Amount shall be based on each Settling State's eligibility to receive one or more Incentive Payment(s) as set out in Section IV.E. For the avoidance of doubt, any Subdivision not listed on Exhibit G shall not receive an allocation from the Subdivision Fund, and no provision of this Agreement shall be interpreted to create such an entitlement.

b. Notice of Dispute. Within twenty-one (21) calendar days of the notice provided by the Settlement Fund Administrator, (1) Walmart, any Settling State or the Enforcement Committee may dispute, in writing, the calculation of the Payout Amount (including the amount allocated for Settlement Fund Administrator costs and fees), whether a Settling State qualifies for an Incentive Payment, or the amount to be received by a Settling State and/or its Participating Subdivisions listed on Exhibit G and (2) a Participating Subdivision may dispute, in writing, the calculation of the amounts under Section IV.C.2.a clauses 3 or 4 solely with respect to such amounts calculated for the Settling State in which it is located and without disputing the amounts calculated under Section IV.C.2.a clauses 1, 2, or 5. A dispute will be deemed invalid and disregarded if it challenges the allocations adopted by a State-Subdivision Agreement approved pursuant to the provisions of Exhibit O or by statute. Such disputing party must provide a written notice of dispute to the Settlement Fund Administrator, the Enforcement Committee, any affected Settling State or Participating Subdivision, and Walmart identifying the nature of the dispute, the amount of money that is disputed, and the Settling State(s) or Participating Subdivision(s) affected.

c. Response to Notice of Dispute. Within twenty-one (21) calendar days of the sending of a written notice of dispute, any affected party may submit a response, in writing, to the Settlement Fund Administrator, the Enforcement Committee, any affected Settling State or Participating Subdivision, and Walmart identifying the basis for disagreement with the notice of dispute.

d. Resolution of Disputes. If no response is filed within the specified time period, the Settlement Fund Administrator shall adjust the amount calculated consistent with the written notice of dispute, the Settlement Fund Administrator shall pay the adjusted Payout Amount, and the dispute shall be considered finally resolved. If a written response to the written notice of dispute is timely sent to the Settlement Fund Administrator, the Settlement Fund Administrator shall notify Walmart and the Enforcement Committee of the preliminary amount to be paid out by the Settlement Fund Administrator, which shall be the smaller of the amount originally calculated by the Settling Administrator or the amount that would be consistent with the notice of dispute, *provided, however*, that in no circumstances shall the preliminary amount to be paid to a Settling State be higher than the maximum amount of Incentive Payment A for that Payment Year.

e. Final resolution of such disputes shall be handled in accordance with the terms of Section VI.F and the Settlement Fund Administrator shall not distribute any amount subject to a dispute being resolved under Section VI.F until such time when the dispute is finally resolved.

3. *Timing of Payments and Reversions.*

a. Payment to the Settling States from the Settlement Fund of the Base Payment will be made as soon as practicable following the Threshold Subdivision Participation Date and the Settlement Fund Administrator's calculation of payment amounts, provision of notice to the Parties, and resolution of any disputes, as applicable and as set forth in Section IV.C.2.a-e (the "*Payout Procedure*"). Any additional payments to the Settling States and/or any reversion to Walmart for Payment Year 1 will be made as soon as practicable following July 15, 2023 or such later date agreed to in writing by Walmart and the Enforcement Committee (the "*First Subdivision Participation Date*") and the Settlement Fund Administrator's completion of the Payout Procedure.

b. In Payment Year 2, payment to the Settling States and/or any reversion to Walmart will be based on Subdivision Participation as of July 15, 2024 or such later date agreed to in writing by Walmart and the Enforcement Committee (the "*Second Subdivision Participation Date*") and will be made as soon as practicable following the Settlement Fund Administrator's completion of the Payout Procedure, as applicable.

c. In Payment Year 3, payment to the Settling States and/or any reversion to Walmart will be based on (i) Subdivision Participation as of July 15, 2025 or such later date agreed to in writing by Walmart and the Enforcement Committee (the "*Third Subdivision Participation Date*") and (ii) eligibility for Incentive D, as set forth in Section IV.E.3, and will be made as soon as practicable following the Settlement Fund Administrator's completion of the Payout Procedure, as applicable.



d. In Payment Years 4 through 6, payment to the Settling States and/or any reversion to Walmart will be based on eligibility for Incentive Payment D, as set forth in Section IV.E.3. Payment will be made as soon as practicable following the Settlement Fund Administrator's completion of the Payout Procedure, as applicable.

e. The Settlement Fund Administrator may combine the payments under this Section IV with funds to be distributed by other comparable opioid settlements. In determining when payments for each Payment Year will be made, the Settlement Fund Administrator may take into account the timeline for the availability of disbursements under other comparable opioid settlements.

D. *Base Payment.* Each Settling State will receive a base payment equal to thirty-eight percent (38%) of such Settling State's Overall Allocation Percentage of the Global Settlement Remediation Amount (the "*Base Payment*"). The Base Payment shall be made as soon as practicable after the Effective Date.

E. *Incentive Payments.* Each Settling State shall be eligible to receive additional incentive payments totaling up to a maximum of sixty two percent (62%) of such Settling State's Overall Allocation Percentage of the Global Settlement Remediation Amount, with the actual amount depending on whether and the extent to which the criteria set forth below are met in such Settling State. In no event shall any Settling State receive more than one hundred percent (100%) of its respective Overall Allocation Percentage of the Global Settlement Remediation Amount under this Agreement. The incentive payments shall be divided among three (3) categories, referred to as Incentive Payments A, BC, and D. As applicable, Incentive Payments A and BC will be paid in at most three payments in Payment Years 1 through 3: one payment in Payment Year 1, one payment in Payment Year 2, and one payment in Payment Year 3. Incentive Payment D will be paid over four installments in Payment Years 3 through 6, provided a Settling State remains eligible to receive Incentive Payment D throughout that period and has not otherwise earned Incentive Payment A. The incentive payments shall be determined by the Settlement Fund Administrator and made with respect to a specific Settling State based on its eligibility for that Payment Year under the criteria set forth below.

1. Incentive Payment A. Incentive Payment A shall be equal to sixty-two (62%) of a Settling State's Overall Allocation Percentage of the Global Settlement Remediation Amount, provided such Settling State becomes eligible for Incentive Payment A and subject to Section IV.E.1.a. Incentive Payment A is mutually exclusive with Incentive Payments BC and D; if a Settling State receives Incentive Payment A, such Settling State is not eligible for Incentive Payments BC or D. If a Settling State is not eligible for Incentive Payment A by the Third Subdivision Participation Date, it shall not be eligible for Incentive Payment A in any succeeding year. Eligibility for Incentive Payment A is as follows:

a. A Settling State is eligible for Incentive Payment A if, as of the First Subdivision Participation Date in Payment Year 1, the Second Subdivision Participation Date in Payment Year 2, or the Third Subdivision Participation Date in Payment Year 3, (i) there is a Bar in that State in full force and effect; (ii) there

is a Settlement Class Resolution in that State in full force and effect; (iii) there is a ruling from the State's highest court barring all Subdivisions from bringing or maintaining Released Claims; (iv) the Released Claims of all of the following entities are released through the execution of Subdivision Participation Agreements: (1) all Litigating Subdivisions, (2) all Non-Litigating Primary Subdivisions, (3) all non-litigating School Districts with a K-12 student enrollment of at least 25,000 or 0.10% of a State's population, whichever is greater, (4) all non-litigating Health Districts and Hospital Districts that have at least one hundred twenty-five (125) hospital beds in one or more hospitals rendering services in that district, and (5) all Primary Fire Districts; or (v) a combination of the actions in clauses (i)-(v) has achieved the same level of resolution of Claims by Subdivisions (e.g., a Bar against future litigation combined with full joinder by Litigating Subdivisions). For the avoidance of doubt, subsection (iv) cannot be satisfied unless all Litigating Subdivisions are Participating Subdivisions or there is a Case-Specific Resolution against any such Subdivisions that are not Participating Subdivisions. Each Settling State that believes it qualifies for Incentive A shall provide notice to Walmart, the Enforcement Committee, and the Settlement Fund Administrator, including data sources or other information establishing such Settling State's entitlement to Incentive A, by the First, Second, or Third Participation Dates, as applicable. Walmart and the Enforcement Committee shall meet and confer in order to agree on data sources for purposes of this Section IV.E.1.a prior to the State Participation Date. For the avoidance of doubt, any disputes regarding whether a Settling State qualifies for Incentive A shall be handled in accordance with the Payout Procedure.

b. If a Settling State becomes eligible for Incentive A in Payment Years 2 or 3, then the Settling State shall be entitled to receive the remaining incentive payments that the Settling State could have earned (the "*Remaining Incentive Payments*"), which equals (i) ninety-seven percent (97%) of such Settling State's Overall Allocation Percentage of the Global Settlement Remediation Amount, representing the maximum Incentive Payment BC, minus any Incentive Payment BC amounts previously paid to such Settling State in Payment Year 1 (or, if such Settling State first becomes eligible for Incentive Payment A in Payment Year 3, the sum of any Incentive Payment BC payment amounts previously paid to the Settling State in Payment Years 1 and 2), the resulting difference of which shall be reduced by 12.5% if Incentive Payment A is achieved in Payment Year 2 or by 25% if Incentive Payment A is achieved in Payment Year 3; and (ii) three percent (3%) of such Settling State's Overall Allocation Percentage of the Global Settlement Remediation Amount, representing Incentive Payment D, as described in Section IV.E.3.

2. Incentive Payment BC. If a Settling State does not qualify for Incentive Payment A, it may still qualify to receive up to fifty-nine percent (59%) of the Settling State's Overall Allocation Percentage of the Global Settlement Remediation Amount under Incentive Payment BC. A Settling State may earn Incentive Payment BC in Payment Years 1 through 3 and may receive, when combined with the Settling State's Base Payment, a

maximum of up to 97% of the Settling State’s Overall Allocation Percentage of the Global Settlement Remediation Amount. Eligibility for Incentive Payment BC is as follows:

a. Subject to Section IV.E.1, the amount of Incentive Payment BC for which a Settling State is eligible shall be determined based on the aggregate population of the Settling State’s Incentive BC Subdivisions that participate in the Agreement or have had their claims resolved through a Case-Specific Resolution, divided by the aggregate population of all of the Settling State’s Incentive BC Subdivisions. The Settling State’s Incentive BC Subdivisions are (i) all Litigating Subdivisions (including School Districts and Special Districts) and (ii) all Non-Litigating Threshold Subdivisions (collectively, all Litigating Subdivisions and all Non-Litigating Threshold Subdivisions are “*Incentive BC Subdivisions*”). The percentage of the Settling State’s Overall Allocation Percentage of the Global Settlement Remediation Amount, inclusive of the Base Payment, to which the Settling State is entitled shall be determined according to the table of Incentive BC payment levels below:

<b>Percentage of Incentive BC Subdivision Population<sup>7</sup></b>	<b>Percentage of Settling State’s Overall Allocation Percentage of the Global Settlement Remediation Amount (includes the Base Payment)</b>
Participation of 85% but less than 86%	Payment of 43%
Participation of 86% but less than 87%	Payment of 46%
Participation of 87% but less than 88%	Payment of 49%
Participation of 88% but less than 89%	Payment of 52%
Participation of 89% but less than 90%	Payment of 55%
Participation of 90% but less than 91%	Payment of 58%
Participation of 91% but less than 92%	Payment of 61%
Participation of 92% but less than 93%	Payment of 64%
Participation of 93% but less than 94%	Payment of 67%
Participation of 94% but less than 95%	Payment of 70%
Participation of 95% but less than 96%	Payment of 75%
Participation of 96% but less than 97%	Payment of 79.5%
Participation of 97% but less than 98%	Payment of 84%
Participation of 98% but less than 99%	Payment of 88.5%
Participation of 99% but less than 100%	Payment of 93% o

<sup>7</sup> The “Percentage of Incentive BC Subdivision Population” shall be determined by the aggregate population of the Settling State’s Incentive BC Subdivisions that participate in the Agreement or have had their claims resolved through a Case-Specific Resolution divided by the aggregate population of the Settling State’s Incentive BC Subdivisions. In calculating the Settling State’s population that resides in Incentive BC Subdivisions, the population of the Settling State’s Incentive BC Subdivisions shall be the sum of the population of all Incentive BC Subdivisions in the Settling State, notwithstanding that persons may be included within the population of more than one Incentive BC Subdivision. An individual Subdivision shall not be included more than once in either the numerator or denominator of the calculation regardless if it (or any of its officials) is named more than once as plaintiffs in the same lawsuit; *provided, however*, that for the avoidance of doubt, no Subdivision will be excluded from the numerator or denominator under this sentence unless a Subdivision otherwise counted in the denominator has the authority to release the Claims (consistent with Section XI) of the Subdivision to be excluded.

Participation of 100%	Payment of 97%
-----------------------	----------------

b. For Payment Year 1, the Settlement Fund Administrator shall calculate and allocate Incentive Payment BC payments to Settling States based on the Settling State’s Incentive BC Subdivision Population participation rate as of the First Subdivision Participation Date. Payments to the Settling States and/or any refund to Walmart shall be made as soon as practicable after the Settlement Fund Administrator’s completion of the Payout Procedure, as applicable.

c. For Payment Year 2, additional payments of Incentive Payment BC shall be made to any Settling State for which the Settling State’s Incentive BC Subdivision Population participation rate as of the Second Subdivision Participation Date results in a higher payment level than for Payment Year 1. Any Incentive Payment BC payment to a Settling State in Payment Year 2 will be 87.5% of the difference between (i) the Incentive BC payment calculated pursuant to Section IV.E.2.a using the Second Subdivision Participation Date and (ii) the Incentive BC payment calculated pursuant to Section IV.E.2.a using the First Subdivision Participation Date. Any payments to Settling States or reversion to Walmart will be made as soon as practicable following the Settlement Fund Administrator’s completion of the Payout Procedure, as applicable.

d. For Payment Year 3, additional payments of Incentive Payment BC shall be made to any Settling State for which the Settling State’s Incentive BC Subdivision Population participation rate as of the Third Subdivision Participation Date results in a higher payment level than for Payment Year 2. Any Incentive Payment BC payment to a Settling State in Payment Year 3 will be 75% of the difference between (i) the Incentive BC payment calculated pursuant to Section IV.E.2.a using the Third Subdivision Participation Date and (ii) the Incentive BC payment calculated pursuant to Section IV.E.2.a using the Second Subdivision Participation Date. Any payments to Settling States or reversion to Walmart will be made as soon as practicable following the Settlement Fund Administrator’s completion of the Payout Procedure, as applicable.

e. The Settlement Fund Administrator shall withhold sufficient funds from Participating Subdivisions in each Payment Year to pay Non-Participating Subdivisions listed on Exhibit G for the Payment Year if they become Participating Subdivisions by the Second Subdivision Participation Date or Third Subdivision Participation Date. If such Non-Participating Subdivisions do not become Participating Subdivisions by the Third Subdivision Participation Date, such withheld funds will be allocated to Participating Subdivisions based on the allocation percentages on Exhibit G. For the avoidance of doubt, nothing in this subsection allows a Non-Participating Subdivision to receive funds until and unless it becomes a Participating Subdivision.

3. Incentive Payment D. Incentive Payment D shall be applied starting at Payment Year 3 and the amount of Incentive Payment D in each year will depend on (i) the Settling State’s eligibility as set out in Section IV.E.3.a and (ii) the Percentage of

Incentive BC Subdivision Population achieved by the Settling State as of the Third Subdivision Participation Date. Incentive Payment D shall be equal to between three percent (3%) and fifteen percent (15%) of the of the Settling State’s Overall Allocation Percentage of the Global Settlement Remediation Amount. The Incentive Payment D may be earned in each of Payment Years 3 through 6. Eligibility for Incentive Payment D is as follows:

a. A Settling State is eligible for Incentive Payment D if there has been no Later Litigating Subdivision (for purposes of Incentive Payment D, Later Litigating Subdivisions are limited to (i) a Primary Subdivision; (ii) a school district with a K-12 student enrollment of at least 25,000 or 0.10% of the State’s population, whichever is greater; (iii) a health district or hospital district that has at least one hundred twenty-five (125) hospital beds in one or more hospitals rendering services in that district; and (iv) Primary Fire Districts) in that State that has had a Claim against a Released Entity survive more than six (6) months after denial in whole or in part of a Threshold Motion as of July 15 of Payment Years 3 to 6 (each, an “*Incentive Payment D Look-Back Date*”).

b. To the extent a Settling State achieves a Percentage of Incentive BC Subdivision Population of 95% or above as of the Third Subdivision Participation Date, the level of Incentive Payment D is reduced according to the schedule below. The following portions of Incentive Payment D are paid in equal installments in Payment Years 3 through 6:

<b>Percentage of Incentive BC Subdivision Population as of the Third Subdivision Participation Date</b>	<b>Incentive Payment D Amount as a Percentage of Settling State’s Overall Allocation Percentage of the Global Settlement Remediation Amount</b>
Participation below 95%	15%
Participation of 95% but less than 96%	13%
Participation of 96% but less than 97%	11%
Participation of 97% but less than 98%	9%
Participation of 98% but less than 99%	7%
Participation of 99% but less than 100%	5%
Participation of 100%	3%

c. The Settlement Fund Administrator shall determine a Settling State’s eligibility for Incentive Payment D as of the Incentive Payment D Look-Back Date in Payment Years 3 through 6. If a Later Litigating Subdivision’s lawsuit in that Settling State survives more than six (6) months after denial in whole or in part of a Threshold Motion, that State shall not be eligible for Incentive Payment D for the Payment Year in which that occurs and any subsequent Payment Year. Prior to the Incentive Payment D Look-Back Date in Payment Years 3 through 6, Walmart may provide the Settlement Fund Administrator and the

Enforcement Committee with notice identifying any Settling State(s) it believes do not qualify for Incentive Payment D and information supporting its belief.

d. If, at any time within six (6) years of the Threshold Subdivision Participation Date, any Subdivision becomes a Later Litigating Subdivision (as that term is limited by Section IV.E.3.a), then Walmart shall, within thirty (30) days of Walmart or any Released Entity being served or otherwise informed of the prosecution of such Released Claims, provide notice to the Settling State in which such Released Claims are being pursued and shall give the relevant Settling State a reasonable opportunity to extinguish the Released Claims without any payment or any other obligations being imposed upon any Released Entities (apart from the Global Settlement Amount payable by Walmart under the Agreement or the Injunctive Relief Terms imposed on it). The relevant Settling State and Walmart shall confer and use reasonable efforts to promptly resolve the lawsuit so that it is dismissed with prejudice. Nothing in this subsection creates an obligation for a Settling State to make a monetary payment or incur any other obligation to an entity filing a lawsuit.

e. Notwithstanding Section IV.E.3, a Settling State can become re-eligible for Incentive Payment D if the lawsuit that survived a Threshold Motion is dismissed pursuant to a later motion on grounds included in the Threshold Motion, in which case the Settling State shall be eligible for any missed payments of Incentive Payment D in the following Payment Year, less any litigation fees and costs incurred by Walmart in the interim, except that if the dismissal motion occurs after the completion of opening statements in such action, the Settling State shall not be eligible for Incentive Payment D.

## **V. Allocation and Use of Settlement Payments**

A. *Components of Settlement Fund.* The Settlement Fund shall be comprised of a Remediation Accounts Fund, a State Fund, and a Subdivision Fund for each Settling State. The payment made under Section IV into the Settlement Fund shall be initially allocated among those three (3) Sub-Funds and distributed and used as provided below or as provided for by a State-Subdivision Agreement (or other State-specific allocation of funds).

### **B. Use of Settlement Payments.**

1. It is the intent of the Parties that the payments disbursed from the Settlement Fund to Settling States and Participating Subdivisions be for Opioid Remediation to address Alleged Harms, subject to exceptions that must be documented in accordance with Section V.B.2. In no event may less than eighty-five percent (85%) of Walmart's maximum payment amounts, distributed pursuant to Section IV, Section VIII, and Section IX as set forth on Exhibit M over the entirety of all Payment Years (but not in any single Payment Year) be spent on Opioid Remediation.

2. While disfavored by the Parties, a Settling State or a Participating Subdivision may, subject to the limitation in the second sentence of Section V.B.1, use

monies from the Settlement Fund (that have not been restricted by this Agreement solely to future Opioid Remediation) for purposes that do not qualify as Opioid Remediation, provided that if, at any time, a Settling State or a Participating Subdivision listed on Exhibit G uses any monies from the Settlement Fund for a purpose that does not qualify as Opioid Remediation, such Settling State or Participating Subdivision listed on Exhibit G shall identify such amounts and report to the Settlement Fund Administrator and Walmart how such funds were used, including if used to pay attorneys' fees, investigation costs, litigation costs, or costs related to the operation and enforcement of this Agreement, respectively. It is the intent of the Parties that the reporting under this Section V.B.2 shall be available to the public. For the avoidance of doubt, (a) any amounts not identified under this Section V.B.2 as used to pay attorneys' fees, investigation costs, or litigation costs shall be included in the "Total Remediation Amount" for purposes of Section V.F and (b) Participating Subdivisions not listed on Exhibit G may only use monies from the Settlement Fund for purposes that qualify as Opioid Remediation.

C. *Allocation of Settlement Fund.* The allocation of the Settlement Fund allows for different approaches to be taken in different States, such as through a State-Subdivision Agreement. Given the uniqueness of States and their Subdivisions, Settling States and their Subdivisions are encouraged to enter into State-Subdivision Agreements in order to direct the allocation of their portion of the Settlement Fund. This Agreement has no effect on the ability of Settling States and their Subdivisions to internally agree on the allocation of their portion of the Settlement Fund. As set out below, the Settlement Fund Administrator will make an initial allocation to three (3) state-level Sub-Funds. The Settlement Fund Administrator will then, for each Settling State and its Participating Subdivisions, apply the terms of this Agreement and any relevant State-Subdivision Agreement, Statutory Trust, Allocation Statute, or voluntary redistribution of funds as set out below before disbursing the funds.

1. Base Payments. The Settlement Fund Administrator will allocate Base Payments under Section IV.D on a State-specific basis in proportion to each Settling State's respective Overall Allocation Percentage. Base Payments for each Settling State will then be allocated fifteen percent (15%) to its State Fund, seventy percent (70%) to its Remediation Accounts Fund, and fifteen percent (15%) to its Subdivision Fund. Amounts may be reallocated and will be distributed as provided in Section V.D.

2. Incentive Payments. The Settlement Fund Administrator will treat incentive payments under Section IV.E on a State-specific basis in proportion to each Settling State's respective Overall Allocation Percentage. Incentive payments for which a Settling State is eligible under Section IV.E will be allocated fifteen percent (15%) to its State Fund, seventy percent (70%) to its Remediation Accounts Fund, and fifteen percent (15%) to its Subdivision Fund. Amounts may be reallocated and will be distributed as provided in Section V.D.

3. Settlement Fund Administrator. Prior to the Threshold Subdivision Participation Date, Walmart and the Enforcement Committee will agree to a detailed mechanism consistent with the foregoing for the Settlement Fund Administrator to follow in allocating, apportioning, and distributing payments, which shall then be appended hereto as Exhibit L.

4. Settlement Fund Administrator Costs. Any costs and fees associated with or arising out of the duties of the Settlement Fund Administrator as described in Exhibit L shall be paid from the interest accrued in the Settlement Fund; *provided, however*, that if such accrued interest is insufficient to pay the entirety of any such costs and fees, Walmart shall pay fifty percent (50%) of the additional amount and fifty percent (50%) shall be paid out of the Settlement Fund.

D. *Settlement Fund Reallocation and Distribution.*

As set forth below, within a particular Settling State's account, amounts contained in the Sub-Funds may be reallocated and distributed per a State-Subdivision Agreement or other means. If the apportionment of amounts is not addressed and controlled under Section V.D.1 and Section V.D.2, then the default provisions of Section V.D.4 apply. It is not necessary that a State-Subdivision Agreement or other means of allocating funds pursuant to Section V.D.1 and Section V.D.2 address all of the Sub-Funds. For example, a Statutory Trust might only address disbursements from a Settling State's Remediation Accounts Fund.

1. Distribution by State-Subdivision Agreement. If a Settling State has a State-Subdivision Agreement, amounts apportioned to that State's State Fund, Remediation Accounts Fund, and Subdivision Fund under Section V.C shall be reallocated and distributed as provided by that agreement. Any State-Subdivision Agreement entered into or amended after November 14, 2022 shall be applied only if it requires: (a) that all amounts be used for Opioid Remediation, except as allowed by Section V.B.2, and (b) that at least seventy percent (70%) of amounts be used solely for future Opioid Remediation.<sup>8</sup> For a State-Subdivision Agreement to be applied to the relevant portion of the Payout Amount, notice must be provided to Walmart and the Settlement Fund Administrator at least sixty (60) calendar days prior to the First, Second, or Third Subdivision Participation Date.

2. Distribution by Allocation Statute. If a Settling State has an Allocation Statute and/or a Statutory Trust that addresses allocation or distribution of amounts apportioned to such State's State Fund, Remediation Accounts Fund, and/or Subdivision Fund and that, to the extent any or all such Sub-Funds are addressed, requires (1) all amounts to be used for Opioid Remediation, except as allowed by Section V.B.2, and (2) at least seventy percent (70%) of all amounts to be used solely for future Opioid Remediation,<sup>9</sup> then, to the extent allocation or distribution is addressed, the amounts apportioned to that State's State Fund, Remediation Accounts Fund, and Subdivision Fund under Section V.C shall be allocated and distributed as addressed and provided by the applicable Allocation Statute or Statutory Trust. For the avoidance of doubt, an Allocation Statute or Statutory Trust need not address all three (3) Sub-Funds that comprise the Settlement Fund, and if the applicable Allocation Statute or Statutory Trust does not

---

<sup>8</sup> Future Opioid Remediation includes amounts paid to satisfy any future demand by another governmental entity to make a required reimbursement in connection with the past care and treatment of a person related to the Alleged Harms.

<sup>9</sup> Future Opioid Remediation includes amounts paid to satisfy any future demand by another governmental entity to make a required reimbursement in connection with the past care and treatment of a person related to the Alleged Harms.



address distribution of all or some of these three (3) Sub-Funds, the applicable Allocation Statute or Statutory Trust does not replace the default provisions described in Section V.D.4 of any such unaddressed fund. For example, if an Allocation Statute or Statutory Trust that meets the requirements of this Section V.D.2 only addresses funds restricted to remediation and abatement, then the default provisions in this Agreement concerning allocation among the three (3) Sub-Funds and the distribution of the State Fund and Subdivision Fund for that State would still apply, while the distribution of the applicable State's Remediation Accounts Fund would be governed by the qualifying Allocation Statute or Statutory Trust.

3. Voluntary Redistribution. A Settling State may choose to reallocate all or a portion of its State Fund to its Remediation Accounts Fund. A Participating Subdivision included on Exhibit G may choose to reallocate all or a portion of its allocation from the Subdivision Fund to the State's Remediation Accounts Fund or to another Participating Subdivision. The Settlement Fund Administrator is not required to honor voluntary redistribution for which notice is provided to it less than sixty (60) days prior to the Payment Date.

4. Distribution in the Absence of a State-Subdivision Agreement, Allocation Statute, or Statutory Trust. If Section V.D.1 and Section V.D.2 do not apply, amounts apportioned to that State's State Fund, Remediation Accounts Fund, and Subdivision Fund under Section V.C shall be distributed as follows:

a. Amounts apportioned to that State's State Fund shall be distributed to that State.

b. Amounts apportioned to that State's Remediation Accounts Fund shall be distributed consistent with Section V.E. Each Settling State shall submit to the Settlement Fund Administrator a designation of a lead state agency or other entity to serve as the single point of contact for that Settling State's funding requests from the Remediation Accounts Fund and other communications with the Settlement Fund Administrator. The designation of an individual entity is for administrative purposes only and such designation shall not limit funding to such entity or even require that such entity receive funds from this Agreement. The designated entity shall be the only entity authorized to request funds from the Settlement Fund Administrator to be disbursed from that Settling State's Remediation Accounts Fund. If a Settling State has established a Statutory Trust, then that Settling State's single point of contact may direct the Settlement Fund Administrator to release the State's Remediation Accounts Fund to the Statutory Trust.

c. Amounts apportioned to that State's Subdivision Fund shall be distributed to Participating Subdivisions in that State included on Exhibit G per the Subdivision Allocation Percentage listed in Exhibit G. Section V.F shall govern amounts that would otherwise be distributed to Non-Participating Subdivisions listed in Exhibit G. For the avoidance of doubt and notwithstanding any other provision in this Agreement, no Non-Participating Subdivision will receive any

amount from the Settlement Fund, regardless of whether such Subdivision is included on Exhibit G.

d. Special Districts shall not be allocated funds from the Subdivision Fund, except through a voluntary redistribution allowed by Section V.D.3. A Settling State may allocate funds from its State Fund or Remediation Accounts Fund for Special Districts.

5. Restrictions on Distribution. No amounts may be distributed from the Subdivision Fund contrary to Section VII, *i.e.*, no amounts may be distributed directly to Non-Participating Subdivisions to the extent such a distribution would violate Section VII.D or Section VII.G. Amounts allocated to the Subdivision Fund that cannot be distributed by virtue of the preceding sentence shall be distributed into the sub-account in the Remediation Accounts Fund for the Settling State in which the Subdivision is located, unless those payments are redirected elsewhere by a State-Subdivision Agreement described in Section V.D.1 or by an Allocation Statute or a Statutory Trust described in Section V.D.2.

E. *Provisions Regarding the Remediation Accounts Fund.*

1. State-Subdivision Agreement, Allocation Statute, and Statutory Trust Fund Provisions. A State-Subdivision Agreement, Allocation Statute, or Statutory Trust may govern the operation and use of amounts in that State's Remediation Accounts Fund so long as it complies with the requirements of Section V.D.1 or Section V.D.2, as applicable, and all direct payments to Subdivisions comply with Section VII.D through Section VII.F.

2. Absence of a State-Subdivision Agreement, Allocation Statute, or Statutory Trust. In the absence of a State-Subdivision Agreement, Allocation Statute, or Statutory Trust that addresses distribution, the Remediation Accounts Fund will be used solely for future Opioid Remediation<sup>10</sup> and the following shall apply with respect to a Settling State:

a. *Regional Remediation.*

(i) At least fifty percent (50%) of distributions for remediation from a State's Remediation Accounts Fund shall be annually allocated and tracked to the regional level. A Settling State may allow the Advisory Committee established pursuant to Section V.E.2.d to define its regions and assign regional allocations percentages. Otherwise, a Settling State shall (A) define its initial regions, which shall consist of one (1) or more General-Purpose Subdivision(s) and which shall be designated by the state agency with primary responsibility for substance abuse disorder services employing, to the maximum extent practical, existing regions established in that State for opioid abuse treatment or other public health purposes; (B) assign initial regional allocation percentages to the regions based on the

---

<sup>10</sup> Future Opioid Remediation includes amounts paid to satisfy any future demand by another governmental entity to make a required reimbursement in connection with the past care and treatment of a person related to the Alleged Harms.

Subdivision Allocation Percentages in Exhibit G and an assumption that all Subdivisions included on Exhibit G will become Participating Subdivisions.

(ii) This minimum regional expenditure percentage is calculated using the Settling State’s initial Remediation Accounts Fund allocation and does not include any additional amounts a Settling State has directed to its Remediation Accounts Fund from its State Fund, or any other amounts directed to the fund. A Settling State may dedicate more than fifty percent (50%) of its Remediation Accounts Fund to the regional expenditure and may annually adjust the percentage of its Remediation Accounts Fund dedicated to regional expenditures as long as the percentage remains above the minimum amount.

(iii) The Settling State (A) has the authority to adjust the definition of the regions, and (B) may annually revise the percentages allocated to each region to reflect the number of General-Purpose Subdivisions in each region that are Non-Participating Subdivisions.

b. *Subdivision Block Grants.* Certain Subdivisions shall be eligible to receive regional allocation funds in the form of block grants for future Opioid Remediation.<sup>11</sup> A Participating Subdivision eligible for block grants is a county or parish (or in the case of States that do not have counties or parishes that function as political subdivisions, a city) that (1) does not contain a Litigating Subdivision or a Later Litigating Subdivision for which it has the authority to end the litigation through a release, bar or other action, (2) either (i) has a population of 400,000 or more or (ii) in the case of California has a population of 750,000 or more, and (3) has funded or otherwise managed an established health care or treatment infrastructure (*e.g.*, health department or similar agency). Each Subdivision eligible to receive block grants shall be assigned its own region.

c. *Small States.* Notwithstanding the provisions of Section V.E.2.a, Settling States with populations under four (4) million that do not have existing regions described in Section V.E.2.a shall not be required to establish regions. However, such a Settling State that contains one (1) or more Subdivisions eligible for block grants under Section V.E.2.c shall be divided regionally so that each block-grant eligible Subdivision is a region and the remainder of the state is a region.

d. *Advisory Committee.* The Settling State shall designate an Opioid Settlement Remediation Advisory Committee (the “*Advisory Committee*”) to provide input and recommendations regarding remediation spending from that Settling State’s Remediation Accounts Fund. A Settling State may elect to use an existing advisory committee or similar entity (created outside of a State-

---

<sup>11</sup> Future Opioid Remediation includes amounts paid to satisfy any future demand by another governmental entity to make a required reimbursement in connection with the past care and treatment of a person related to the Alleged Harms.

Subdivision Agreement or Allocation Statute); *provided, however*, the Advisory Committee or similar entity shall meet the following requirements:

(i) Written guidelines that establish the formation and composition of the Advisory Committee, terms of service for members, contingency for removal or resignation of members, a schedule of meetings, and any other administrative details;

(ii) Composition that includes at least an equal number of local representatives as state representatives;

(iii) A process for receiving input from Subdivisions and other communities regarding how the opioid crisis is affecting their communities, their abatement needs, and proposals for abatement strategies and responses; and

(iv) A process by which Advisory Committee recommendations for expenditures for Opioid Remediation will be made to and considered by the appropriate state agencies.

3. Remediation Accounts Fund Reporting. The Settlement Fund Administrator shall track and assist in the report of remediation disbursements as agreed to between Walmart and the Enforcement Committee.

F. *Nature of Payment.* Walmart, the Settling States, and the Participating Subdivisions each acknowledge and agree that notwithstanding anything to the contrary in this Agreement, including, but not limited to, the scope of the Released Claims:

1. They have entered into this Agreement to avoid the delay, expense, inconvenience, and uncertainty of further litigation;

2. (a) The Settling States and Participating Subdivisions sought restitution and remediation (within the meaning of 26 U.S.C. § 162(f)(2)(A) and 26 C.F.R. § 1.162-21(e)(4)(i), (ii)) as damages for the Alleged Harms; (b) the Total Remediation Amount is less than or equal to the amount, in the aggregate, of the Alleged Harms allegedly suffered by the Settling States and Participating Subdivisions; and (c) the portion of the Total Remediation Amount received by each Settling State or Participating Subdivision is less than or equal to the amount of the Alleged Harms allegedly suffered by such Settling State or Participating Subdivision;

3. The payment of the Total Remediation Amount by Walmart constitutes restitution and remediation (within the meaning of 26 U.S.C. § 162(f)(2)(A) and 26 C.F.R. § 1.162-21(e)(4)(i), (ii)) for alleged damage or harm (as compensation for alleged damage or harm arising out of alleged bodily injury) allegedly caused by Walmart in order to restore, in whole or in part, the Settling States, Participating Subdivisions, and persons to the same position or condition that they would be in had the Settling States, Participating Subdivisions, and persons not suffered the Alleged Harms, and constitutes restitution and

remediation for alleged damage or harm allegedly caused by the potential violation of a law and/or is an amount paid to come into compliance with the law; and

4. For the avoidance of doubt: (a) the entire Total Remediation Amount is properly characterized as described in Section V.F, (b) no portion of the Total Remediation Amount represents reimbursement to any Settling State or Participating Subdivision or other person or entity for the fees or costs of any investigation or litigation, including without limitation attorneys' fees, (c) no portion of the Global Settlement Amount represents the disgorgement of any allegedly ill-gotten gains, and (d) no portion of the Global Settlement Amount is paid for or in place of any fine, penalty, punitive damages, or other punitive assessments.

## **VI. Enforcement**

A. *Enforceability.* This Agreement is enforceable only by the Settling States and Walmart; *provided, however*, that Released Entities may enforce Section X and Participating Subdivisions have the enforcement rights described in Section VI.D. Except to the extent allowed by the Injunctive Relief Terms, Settling States and Participating Subdivisions shall not have enforcement rights with respect to either the terms of this Agreement that apply only to or in other States or any Consent Judgment entered into by another Settling State. Participating Subdivisions shall not have enforcement rights against Walmart with respect to this Agreement or any Consent Judgment except that Participating Subdivisions shall have enforcement rights as set forth herein as to payments that would be allocated to the Subdivision Fund or Remediation Accounts Fund pursuant to Section V; *provided, however*, that each Settling State shall allow Participating Subdivisions in such Settling State to notify it of any perceived violations of this Agreement or the applicable Consent Judgment.

B. *Jurisdiction.* Walmart consents to the jurisdiction of the court in which the Consent Judgment is filed, limited to resolution of disputes identified in Section VI.F.2 for resolution in that court.

C. *Specific Terms Dispute Resolution.*

1. Any dispute that is addressed by the provisions set forth in the Injunctive Relief Terms shall be resolved as provided therein.

2. In the event that Walmart believes that the eighty-five percent (85%) requirement established in Section V.B.1 is not being satisfied, Walmart may request that Walmart and the Enforcement Committee meet and confer regarding the use of funds to implement Section V.B.1. The completion of such meet-and-confer process is a precondition to further action regarding any such dispute. Further action concerning Section V.B.1 shall (i) be limited to Walmart obtaining a reversion of its Payout Amount by no more than five percent (5%) of the difference between the actual amount of Opioid Remediation and the eighty-five percent (85%) requirement established in Section V.B.1; and (ii) only reduce payments to those Settling States and their Participating Subdivisions that are below the eighty-five percent (85%) requirement established in Section V.B.1;

provided that Walmart shall not obtain a reversion of funds restricted to future Opioid Remediation.

D. *State-Subdivision Enforcement.*

1. A Subdivision shall not have enforcement rights against a Settling State in which it is located with respect to this Agreement or any Consent Judgment except that a Participating Subdivision listed on Exhibit G shall have enforcement rights (a) as provided for in a State-Subdivision Agreement, Allocation Statute, or Statutory Trust with respect to intrastate allocation (b) in the absence of a State-Subdivision Agreement, Allocation Statute, or Statutory Trust, to address allegations that (i) the Settling State's use of Remediation Accounts Fund monies were not used for uses similar to or in the nature of those uses contained in Exhibit E; or (ii) a Settling State failed to pay funds directly from the Remediation Accounts Fund to a Participating Subdivision eligible to receive a block grant pursuant to Section V.E.2.b.

2. A Settling State shall have enforcement rights against a Participating Subdivision located in its territory (a) as provided for in a State-Subdivision Agreement, Allocation Statute, or Statutory Trust; or (b) in the absence of a State-Subdivision Agreement, Allocation Statute, or Statutory Trust, to address allegations that the Participating Subdivisions' uses of Remediation Accounts Fund monies were not used for purposes similar to or in the nature of those uses contained in Exhibit E.

3. As between Settling States and Participating Subdivisions, the above rights are contractual in nature and nothing herein is intended to limit, restrict, change or alter any other existing rights under law.

E. *Subdivision Payment Enforcement.* A Participating Subdivision listed on Exhibit G shall have the same right as a Settling State pursuant to Section VI.F.3.a(iv) to seek resolution regarding the failure by Walmart to make its Payout Amount.

F. *Other Terms Regarding Dispute Resolution.*

1. Except as provided by Section VI.C, the parties to a dispute shall promptly meet and confer in good faith to resolve any dispute. If the parties cannot resolve the dispute informally, and unless otherwise agreed in writing, they shall follow the remaining provisions of this Section VI.F to resolve the dispute.

2. Except to the extent provided by Section VI.C or Section VI.F.3, all disputes shall be resolved in either the court that entered the relevant Consent Judgment or, if no such Consent Judgment was entered, a state or territorial court with jurisdiction located wherever the seat of the relevant state government is located.

a. State court proceedings shall be governed by the rules and procedures of the relevant forum.

b. For the avoidance of doubt, disputes to be resolved in state court include, but are not limited to, the following:

(i) disputes concerning whether expenditures qualify as Opioid Remediation;

(ii) disputes between a Settling State and its Participating Subdivisions as provided by Section VI.D, except to the extent the State-Subdivision Agreement provides for other dispute resolution mechanisms. For the avoidance of doubt, disputes between a Settling State and any Participating Subdivision shall not be considered National Disputes;

(iii) whether this Agreement and relevant Consent Judgment are binding under state law;

(iv) the extent of the Attorney General's or other participating entity's authority under state law, including the extent of the authority to release claims;

(v) whether the definition of a Bar, a Case-Specific Resolution, Final Order, lead state agency as described in Section V.D.4.b, Later Litigating Subdivision, Litigating Subdivision, or Threshold Motion have been met; and

(vi) all other disputes not specifically identified in Section VI.C or Section VI.F.3.

c. Any Party may request that the National Arbitration Panel provide an interpretation of any provision of the settlement that is relevant to the state court determination, and the National Arbitration Panel shall make reasonable best efforts to supply such interpretation within the earlier of thirty (30) calendar days or the time period required by the state court proceedings. Any Party may submit that interpretation to the state court to the extent permitted by, and for such weight provided by, the state court's rules and procedures. If requested by a Party, the National Arbitration Panel shall request that its interpretation be accepted in the form of an *amicus curiae* brief, and any attorneys' fees and costs for preparing any such filing shall be paid for by the requesting Party.

3. National Disputes involving a Settling State, a Participating Subdivision that has enforcement rights pursuant to Section VI.A, and/or Walmart (together, "*Participating Parties*") shall be resolved by the National Arbitration Panel.

a. National Disputes are disputes that are not addressed by Section VI.C, and which are exceptions to Section VI.F.2's presumption of resolution in state courts because they involve issues of interpretation of terms contained in this Agreement applicable to all Settling States without reference to a particular State's law. Disputes between a Settling State and any Participating Subdivision shall not be considered National Disputes. National Disputes are limited to the following:

(i) the amount of withholding attributable to Non-Settling States;

- (ii) issues involving the scope and definition of Product;
- (iii) interpretation and application of the terms “Alleged Harms,” “Covered Conduct,” “Released Entities,” and “Released Claims”;
- (iv) the failure by the Settlement Fund Administrator to pay the Payout Amount or the Additional Remediation Amount in a Payment Year, but for the avoidance of doubt, disputes between Walmart and a Settling State over the amounts owed only to that state that do not affect any other Settling State shall not be considered National Disputes;
- (v) the interpretation and application of any most-favored-nation provision in Section XII.E;
- (vi) questions regarding the performance and/or removal of the Settlement Fund Administrator;
- (vii) disputes involving liability of successor entities;
- (viii) disputes that require a determination of the sufficiency of participation in order to qualify for Incentive Payments A, BC or D;
- (ix) disputes requiring the interpretation of Agreement terms that are national in scope or impact, which shall mean disputes requiring the interpretation of Agreement terms that (i) concretely affect four (4) or more Settling States; and (ii) do not turn on unique definitions and interpretations under state law; and
- (x) any dispute subject to resolution under Section VI.F.1 but for which all parties to the dispute agree to arbitration before the National Arbitration Panel under the provisions of this Section VI.F.2.

b. The National Arbitration Panel shall be comprised of three (3) arbitrators. One (1) arbitrator shall be chosen by Walmart, one (1) arbitrator shall be chosen by the Enforcement Committee with due input from Participating Subdivisions listed on Exhibit G, and the third arbitrator shall be agreed upon by the first two (2) arbitrators. The membership of the National Arbitration Panel is intended to remain constant throughout the term of this Agreement, but in the event that replacements are required, the retiring arbitrator shall be replaced by the party that selected him/her.

c. The National Arbitration Panel shall make reasonable best efforts to decide all matters within one hundred eighty (180) calendar days of filing, and in no event shall it take longer than one (1) year.

d. The National Arbitration Panel shall conduct all proceedings in a reasonably streamlined process consistent with an opportunity for the parties to be heard. Issues shall be resolved without the need for live witnesses where feasible,



and with a presumption in favor of remote participation to minimize the burdens on the Participating Parties.

e. To the extent allowed under state law, a Settling State, a Participating Subdivision that has enforcement rights pursuant to Section VI.A, and (at any Participating Party's request) the National Arbitration Panel may certify to an appropriate state court any question of state law. The National Arbitration Panel shall be bound by a final state court determination of such a certified question. The time period for the arbitration shall be tolled during the course of the certification process.

f. The arbitrators will give due deference to any authoritative interpretation of state law, including any declaratory judgment or similar relief obtained by a Settling State, a Participating Subdivision that has enforcement rights pursuant to Section VI.A, or Walmart on a state law issue.

g. The decisions of the National Arbitration Panel shall be binding on Settling States, Participating Subdivisions, Walmart, and the Settlement Fund Administrator. In any proceeding before the National Arbitration Panel involving a dispute between a Settling State and Walmart whose resolution could prejudice the rights of a Participating Subdivision(s) in that Settling State, such Participating Subdivision(s) shall be allowed to file a statement of view in the proceeding.

h. Nothing herein shall be construed so as to limit or otherwise restrict a State from seeking injunctive or other equitable relief in state court to protect the health, safety, or welfare of its citizens.

i. Each Participating Party shall bear its own costs in any arbitration or court proceeding arising under this Section VI. The costs for the arbitrators on the National Arbitration Panel shall be divided and paid equally by the disputing sides for each individual dispute, *e.g.*, a dispute between Walmart and Settling States/Participating Subdivisions shall be split fifty percent (50%) by Walmart and fifty percent (50%) by the Settling States/Participating Subdivisions that are parties to the dispute; a dispute between a Settling State and a Participating Subdivision shall be split fifty percent (50%) by the Settling State that is party to the dispute and fifty percent (50%) by any Participating Subdivisions that are parties to the dispute.

4. Prior to initiating an action to enforce pursuant to this Section VI.F, the complaining Participating Party must:

a. Provide written notice to the Enforcement Committee of its complaint, including the provision of the Consent Judgment and/or Agreement that the practice appears to violate, as well as the basis for its interpretation of the disputed provision. The Enforcement Committee shall establish a reasonable process and timeline for obtaining additional information from the involved parties; *provided, however*, that the date the Enforcement Committee establishes for

obtaining additional information from the parties shall not be more than forty-five (45) calendar days following the notice. The Enforcement Committee may advise the involved parties of its views on the complaint and/or seek to resolve the complaint informally.

b. Wait to commence any enforcement action until thirty (30) calendar days after the date that the Enforcement Committee establishes for obtaining additional information from the involved parties.

5. If the Participating Parties to a dispute cannot agree on the proper forum for resolution of the dispute under the provisions of Section VI.F.1 or Section VI.F.2, a committee comprising the Enforcement Committee and sufficient representatives of Walmart such that the members of the Enforcement Committee have a majority of one (1) member will determine, within twenty-eight (28) calendar days of receiving notification of the dispute relating to the proper forum, the forum where the dispute will be initiated. The forum identified by such committee shall be the sole forum for resolving the issue of which forum will hear the substantive dispute, and the committee's identification of such forum in the first instance shall not be entitled to deference by the forum selected.

G. *No Effect.* Nothing in this Agreement shall be interpreted to limit the Settling States' Civil Investigative Demand ("CID") or investigative subpoena authority, to the extent such authority exists under applicable state law and the CID or investigative subpoena is issued pursuant to such authority, and Walmart reserves all of its rights in connection with a CID or investigative subpoena issued pursuant to such authority.

## **VII. Participation by Subdivisions**

A. *Notice.* Prior to the State Participation Date, the Parties shall agree on a vendor to serve as the Implementation Administrator and provide notice pursuant to this Section VII.A. No later than fifteen (15) calendar days after the State Participation Date, the Implementation Administrator shall send individual written notice (which may be delivered via e-mail or other electronic means) of the opportunity to participate in this Agreement and the requirements of participation to all Subdivisions in the Settling States that are (1) Litigating Subdivisions or (2) Non-Litigating Subdivisions listed on Exhibit G. To the extent a Special District is entitled to an allocation for a direct payment through its inclusion in Exhibit G pursuant to a State-Subdivision Agreement, Allocation Statute, Statutory Trust, or voluntary redistribution, the Implementation Administrator, with the cooperation of the Settling States, shall also send individual written notice (which may be delivered via e-mail or other electronic means) of the opportunity to participate in this Agreement and the requirements of participation to such Special Districts. Unless otherwise agreed by the Parties, the version of Exhibit G used for notice shall be the one in place as of the State Participation Date. Notice (which may be delivered via e-mail or other electronic means) shall also be provided simultaneously to counsel of record for Litigating Subdivisions and known counsel for Non-Litigating Subdivisions and Special Districts listed on Exhibit G. The notice will include that the deadline for becoming a Participating Subdivision is the Threshold Subdivision Participation Date. Nothing contained herein shall preclude a Settling State from providing further notice to or otherwise contacting any of its Subdivisions about becoming a Participating

Subdivision, including beginning any of the activities described in this paragraph prior to the State Participation Date.

B. *Requirements for Becoming a Participating Subdivision—Non-Litigating Subdivisions.* A Non-Litigating Subdivision in a Settling State may become a Participating Subdivision by returning an executed Subdivision Participation Agreement to the Settlement Fund Administrator (subject to Section VII.D) specifying (1) that the Subdivision agrees to the terms of this Agreement pertaining to Subdivisions, (2) that the Subdivision releases all Released Claims against all Released Entities, (3) that the Subdivision agrees to use monies it receives, if any, from the Settlement Fund pursuant to the applicable requirements of Section V; *provided, however*, that Non-Litigating Subdivisions may only use monies originating from the Settlement Fund for purposes that qualify as Opioid Remediation, and (4) that the Subdivision submits to the jurisdiction of the court where the relevant state seat of government is located for purposes limited to that court's role under this Agreement. The required Participation Agreement is attached as Exhibit K.

C. *Requirements for Becoming a Participating Subdivision—Litigating Subdivisions/Later Litigating Subdivisions.* A Litigating Subdivision or Later Litigating Subdivision in a Settling State may become a Participating Subdivision by returning an executed Subdivision Participation Agreement to the Settlement Fund Administrator (subject to Section VII.D) and upon prompt dismissal with prejudice of its lawsuit following the Threshold Subdivision Participation Date or the date on which the conditions for effectiveness in Section II.C have been met, whichever is later. A Settling State may require each Litigating Subdivision in that State to specify on the Participation Agreement whether its counsel has waived any contingency fee contract with that Participating Subdivision and whether, if eligible, it intends to seek fees pursuant to Exhibit R. The Settlement Fund Administrator shall provide quarterly reports of this information to the parties organized by Settling State. A Litigating Subdivision or Later Litigating Subdivision may not become a Participating Subdivision after the completion of opening statements in a trial of the lawsuit it brought that includes a Released Claim against a Released Entity. For avoidance of doubt, where a subdivision official other than a General-Purpose Government has filed a lawsuit that includes a Released Claim against a Released Entity in a direct, *parens patriae*, or any other capacity, that Subdivision may become a Participating Subdivision only if, in addition to the other requirements of this Section VII.C, the lawsuit filed by the subdivision official has also been dismissed with prejudice.

D. All Subdivision Participation Agreements returned to the Settlement Fund Administrator prior to the Effective Date (if any) shall be held by the Settlement Fund Administrator until the Effective Date, at which time the obligations created by such forms and releases in them become effective. If, for any reason, the Settlement Agreement does not become effective, all obligations created by such forms and releases in them shall be void *ab initio* and all Settlement Participation Forms shall be returned to Counsel for Litigating Subdivisions or to the Subdivisions not represented by counsel or destroyed to the extent that such destruction is not prohibited by then-existing document preservation obligations.

E. *Ineligible Subdivisions.* Subdivisions in Non-Settling States and Prior Litigating Subdivisions are not eligible to be Participating Subdivisions.

F. *Non-Participating Subdivisions.* Non-Participating Subdivisions shall not directly receive any portion of any Payout Amount, including from the State Fund and direct distributions from the Remediation Accounts Fund; however, a Settling State may choose to fund future Opioid Remediation that indirectly benefits Non-Participating Subdivisions.

G. *Unpaid Allocations to Non-Participating Subdivisions.* Any payments allocated pursuant to Section V.D to a Non-Participating Subdivision that cannot be paid pursuant to this Section VII will either be allocated to the Settlement Fund for the Settling State in which the Non-Participating Subdivision is located, unless those payments are redirected elsewhere by a State-Subdivision Agreement or by a Statutory Trust, or be refunded to Walmart, if such funds may no longer be earned by the applicable Settling State pursuant to Section IV.C.1.

## **VIII. Additional Remediation**

A. *Additional Remediation Amount.* Pursuant to the maximum payment amounts set forth in Exhibit M and subject to the reduction specified in Section VIII.B, Walmart shall pay an Additional Remediation Amount to the Settling States.

B. *Reduction of Additional Remediation Amount.* The amounts owed by Walmart pursuant to this Section VIII shall be reduced by the allocations set forth on Exhibit N for any Non-Settling States.

C. *Use of Funds.* All funds paid as an Additional Remediation Amount shall be part of the Total Remediation Amount, shall be used for Opioid Remediation, except as allowed by Section V.B.2, and shall be governed by the same requirements as specified in Section V.F. Such funds shall be disbursed by the Settlement Fund Administrator to the relevant Settling States as allocated by Exhibit N as part of the first payment in Payment Year 1.

D. For the avoidance of doubt, (1) notwithstanding anything to the contrary in Section VIII.C, but subject to the limitation in the second sentence of Section V.B.1 and the identification and reporting requirements in Section V.B.2, a Settling State that retained outside counsel in connection with the investigation of one or more Chain Pharmacies, as that term is defined in Exhibit S, that receives an Additional Remediation Amount because the Settling State was not otherwise eligible to receive funds from the State Outside Counsel Fee Fund may choose to have the Additional Remediation Amount designated to pay the Settling State's outside counsel, and may instruct the Settlement Fund Administrator to pay those funds directly to the Settling State's outside counsel, and (2) Additional Remediation Amount funds, including funds designated by a Settling State to pay its outside counsel under this paragraph, shall not be subject to allocation as provided in Sections V.C through V.E.

## **IX. Plaintiffs' Attorneys' Fees and Costs**

The Agreement on Attorneys' Fees, Costs, and Expenses is set forth in Exhibit R and incorporated herein by reference. The Agreement on the State Outside Counsel Fee Fund and Agreement on the Joint State Cost Fund are set forth in Exhibit S and Exhibit T, respectively, and are incorporated herein by reference.

## **X. Release**

A. *Scope.* As of the Threshold Subdivision Participation Date, the Released Entities are hereby released and forever discharged from all of the Releasors' Released Claims. Each Settling State (for itself and its Releasors) and Participating Subdivision (for itself and its Releasors) hereby absolutely, unconditionally, and irrevocably covenants not to bring, file, or claim; or to cause, assist in bringing or permit to be brought, filed, or claimed; or to otherwise seek to establish liability for any Released Claim against any Released Entity in any forum whatsoever. The releases provided for in this Agreement are broad, shall be interpreted so as to give the Released Entities the broadest possible bar against any liability relating in any way to any Released Claim, and extend to the full extent of the power of each Settling State and its Attorney General to release claims. This Agreement shall be a complete bar to any Released Claim.

### **B. Claim-Over and Non-Party Settlement.**

1. It is the intent of the Parties that:

a. Released Entities should not seek contribution or indemnification (other than pursuant to an insurance contract), from other parties for their payment obligations under this Agreement;

b. the payments made under this Agreement shall be the sole payments made by the Released Entities to the Releasors involving, arising out of, or related to Alleged Harms and/or Covered Conduct (or conduct that would be Covered Conduct if engaged in by a Released Entity);

c. Claims by Releasors against non-Parties shall not result in additional payments by Released Entities, whether through contribution, indemnification or any other means; and

d. the Agreement meets the requirements of the Uniform Contribution Among Joint Tortfeasors Act and any similar state law or doctrine that reduces or discharges a released party's liability to any other parties.

The provisions of this Section X.B are to be implemented consistent with these principles. This Agreement and the releases and dismissals provided for herein are made in good faith.

2. No Released Entity shall seek to recover for amounts paid under this Agreement based on indemnification, contribution, or any other theory from a manufacturer, pharmacy, hospital, pharmacy benefit manager, health insurer, third-party vendor, trade association, distributor, or health care practitioner; *provided* that a Released Entity shall be relieved of this prohibition with respect to any entity that asserts a Claim-Over against it. For the avoidance of doubt, nothing herein shall prohibit a Released Entity from recovering amounts owed pursuant to insurance contracts.

3. If any Releasor enters into a Non-Party Settlement on or after the Effective Date, including in any bankruptcy case or through any plan of reorganization (whether individually or as a class of creditors), the Releasor will include (or in the case of a Non-

Party Settlement made in connection with a bankruptcy case, will cause the debtor to include), unless prohibited from doing so under applicable law, in the Non-Party Settlement a prohibition on contribution or indemnity of any kind substantially equivalent to that required from Walmart in Section X.B.2, or a release from such Non-Released Entity in favor of the Released Entities (in a form equivalent to the releases contained in this Agreement) of any Claim-Over. The obligation to obtain the prohibition and/or release required by this subsection is a material term of this Agreement.

4. If any Releasor obtains a judgment with respect to a Non-Party Covered Conduct Claim against a Non-Released Entity that does not contain the prohibition described in Section X.B.3, or any Releasor files a Non-Party Covered Conduct Claim against a Non-Released Entity in bankruptcy or a Releasor is prevented for any reason from obtaining a prohibition/release in a Non-Party Settlement as provided in Section X.B.3, and such Non-Released Entity asserts a Claim-Over against a Released Entity, the Released Entity shall be relieved of the prohibition in Section X.B.2 with respect to that Non-Released Entity and that Releasor and Walmart shall take the following actions to ensure that the Released Entities do not pay more with respect to Alleged Harms and/or Covered Conduct to Releasors or to Non-Released Entities than the amounts owed under this Settlement Agreement by Walmart:

a. Walmart shall notify that Releasor of the Claim-Over within sixty (60) calendar days of the assertion of the Claim-Over or sixty (60) calendar days of the Effective Date of this Agreement, whichever is later;

b. Walmart and that Releasor shall meet and confer concerning the means to hold Released Entities harmless and ensure that they are not required to pay more with respect to Alleged Harms and/or Covered Conduct than the amounts owed by Walmart under this Agreement;

c. That Releasor and Walmart shall take steps sufficient and permissible under the law of the State of the Releasor to hold Released Entities harmless from the Claim-Over and ensure Released Entities are not required to pay more with respect to Alleged Harms and/or Covered Conduct than the amounts owed by Walmart under this Agreement. Such steps may include, where permissible:

(i) Filing of motions to dismiss or such other appropriate motion by Walmart or Released Entities, and supported by Releasors, in response to any claim filed in litigation or arbitration;

(ii) Reduction of that Releasors' Claim and any judgment it has obtained or may obtain against such Non-Released Entity by whatever amount is necessary to extinguish such Claim-Over under applicable law, up to the amount that Releasor has obtained, may obtain, or has authority to control from such Non-Released Entity;

(iii) Placement into escrow of funds paid by the Non-Released Entities such that those funds are available to satisfy the Claim-Over;

(iv) Return of monies paid by Walmart to that Releasor under this Agreement to permit satisfaction of a judgment against or settlement with the Non-Released Entity to satisfy the Claim-Over;

(v) Payment of monies to Walmart by that Releasor to ensure Walmart is held harmless from such Claim-Over, up to the amount that Releasor has obtained, may obtain, or has authority to control from such Non-Released Entity;

(vi) Credit to Walmart under this Agreement to reduce the overall amounts to be paid under the Agreement such that it is held harmless from the Claim-Over; and

(vii) Such other actions as that Releasor and Walmart may devise to hold Walmart harmless from the Claim-Over.

d. The actions of that Releasor and Walmart taken pursuant to clause (c) above must, in combination, ensure Walmart is not required to pay more with respect to Alleged Harms and/or Covered Conduct than the amounts owed by Walmart under this Agreement.

e. In the event of any dispute over the sufficiency of the actions taken pursuant to clause (c) above, Releasor and Walmart may seek review by the National Arbitration Panel, or, upon consent of the parties to the dispute, by the state court where the relevant Consent Judgment was filed. The National Arbitration Panel shall have authority to order a remedy, including one or more of the actions specified in clause (c), sufficient to hold Released Entities fully harmless. In the event that the Panel's actions do not result in Released Entities being held fully harmless, Walmart shall have a claim for breach of this Agreement by Releasors, with the remedy being payment of sufficient funds to hold Walmart harmless from the Claim-Over. For the avoidance of doubt, the prior sentence does not limit or eliminate any other remedy that Walmart may have.

5. To the extent that the Claim-Over is based on a contractual indemnity, the obligations under Section X.B.4 shall extend solely to a Non-Party Covered Conduct Claim against a pharmacy, distributor, clinic, hospital or other purchaser or dispenser of Products, a manufacturer that sold Products, a consultant, and/or a pharmacy benefit manager or other third-party payor. Walmart shall notify the Settling States, to the extent permitted by applicable law, in the event that any of these types of Non-Released Entity asserts a Claim-Over arising out of contractual indemnity against it.

C. *Indemnification and Contribution Prohibited.* No Released Entity shall seek to recover for amounts paid under this Agreement based on indemnification, contribution, or any other theory, from a manufacturer, pharmacy, hospital, pharmacy benefit manager, health insurer, third-party vendor, trade association, distributor, or health care practitioner; *provided* that a

Released Entity shall be relieved of this prohibition with respect to any entity that asserts a Claim-Over against it. For the avoidance of doubt, nothing herein shall prohibit a Released Entity from recovering amounts owed pursuant to insurance contracts. For the avoidance of doubt, nothing herein shall prohibit a Released Entity from recovering amounts owed pursuant to insurance contracts.

D. *General Release.* In connection with the releases provided for in this Agreement, each Settling State (for itself and its Releasers) and Participating Subdivision (for itself and its Releasers) expressly waives, releases, and forever discharges any and all provisions, rights, and benefits conferred by any law of any State or territory of the United States or other jurisdiction, or principle of common law, which is similar, comparable, or equivalent to § 1542 of the California Civil Code, which reads:

**General Release; extent.** A general release does not extend to claims that the creditor or releasing party does not know or suspect to exist in his or her favor at the time of executing the release and that if known by him or her, would have materially affected his or her settlement with the debtor or released party.

A Releaser may hereafter discover facts other than or different from those which it knows, believes, or assumes to be true with respect to the Released Claims, but each Settling State (for itself and its Releasers) and Participating Subdivision (for itself and its Releasers) hereby expressly waives and fully, finally, and forever settles, releases and discharges, upon the Effective Date, any and all Released Claims that may exist as of such date even if Releasers do not know or suspect such claims to exist, whether through ignorance, oversight, error, negligence or through no fault whatsoever, and even if knowledge of the existence of such claims would materially affect the Settling States' decision to enter into this Agreement or the Participating Subdivisions' decision to participate in this Agreement.

E. *Assigned Interest Waiver.* To the extent that any Settling State has any direct or indirect interest in any rights of a third-party that is a debtor under the Bankruptcy Code as a result of a claim arising out of Covered Conduct or Alleged Harms by way of assignment or otherwise, including as a result of being the beneficiary of a trust or other distribution entity, to assert claims against Walmart (whether derivatively or otherwise), under any legal or equitable theory, including for indemnification, contribution, or subrogation, such Settling State waives the right to assert any such claim, or to receive a distribution or any benefit on account of such claim and such claim, distribution, or benefit shall be deemed assigned to Walmart.

F. *Res Judicata.* Nothing in this Agreement shall be deemed to reduce the scope of the res judicata or claim preclusive effect that the settlement memorialized in this Agreement, and/or any Consent Judgment or other judgment entered on this Agreement, gives rise to under applicable law.

G. *Representation and Warranty.* The signatories hereto on behalf of their respective Settling States expressly represent and warrant that they have (or will obtain no later than the Threshold Subdivision Participation Date) the authority to settle and release, to the maximum extent of the State's power, all Released Claims of (1) their respective Settling States, (2) all past



and present executive departments, state agencies, divisions, boards, commissions and instrumentalities with the regulatory authority to enforce state and federal controlled substances acts, and (3) any of their respective Settling State's past and present executive departments, agencies, divisions, boards, commissions and instrumentalities that have the authority to bring Claims related to Alleged Harms and/or Covered Conduct seeking money (including abatement and/or remediation) or revocation of a pharmaceutical distribution or dispensing license. For the purposes of clause (3) above, executive departments, agencies, divisions, boards, commissions, and instrumentalities are those that are under the executive authority or direct control of the State's Governor. Also for the purposes of clause (3), a release from a State's Governor, to be materially similar to that in Exhibit X, is sufficient to demonstrate that the appropriate releases have been obtained.

H. *Effectiveness.* The releases set forth in this Agreement shall not be impacted in any way by any dispute that exists, has existed, or may later exist between or among the Releasors. Nor shall such releases be impacted in any way by any current or future law, regulation, ordinance, or court or agency order limiting, seizing, or controlling the distribution or use of the Settlement Fund or any portion thereof, or by the enactment of future laws, or by any seizure of the Settlement Fund or any portion thereof.

I. *Cooperation.* Settling States will meet and confer with Walmart and simultaneously make reasonable efforts to resolve any action filed by a Subdivision involving any Covered Conduct, Alleged Harms, or a Product that remains pending against Walmart after the First Subdivision Participation Date or that is filed by a Subdivision against Walmart after November 14, 2022. Releasors (i) will not encourage any person or entity to bring or maintain any Released Claim against any Released Entity and (ii) will reasonably cooperate with and not oppose any effort by a Released Entity to secure the prompt dismissal of any and all Released Claims.

J. *Non-Released Claims.* Notwithstanding the foregoing or anything in the definition of Released Claims, this Agreement does not waive, release or limit any criminal liability, Claims for liability under tax law, Claims under securities law by a State Releasor as investor, Claims against parties who are not Released Entities, Claims by private individuals, and any Claims arising under this Agreement for enforcement of this Agreement.

## **XI. Later Litigating Subdivisions; Non-Settling States**

A. *Released Claims against Released Entities.* If a Later Litigating Subdivision in a Settling State maintains a lawsuit for a Released Claim against a Released Entity after the Effective Date, the Released Entity shall take ordinary and reasonable measures to defend the action, including filing a Threshold Motion with respect to the Released Claim. The Released Entity shall further notify the Settling State and Settlement Fund Administrator immediately upon notice of a Later Litigating Subdivision bringing a lawsuit for a Released Claim and shall not oppose a Settling State's submission in support of the Threshold Motion. Walmart shall give the relevant Settling State a reasonable opportunity to extinguish the Released Claims without any payment or any other obligations being imposed upon any Released Entities (apart from the Global Settlement Amount payable by Walmart under the Agreement or the Injunctive Relief Terms incurred by it). The relevant Settling State and Walmart shall confer and use reasonable efforts to promptly resolve

the lawsuit so that it is dismissed with prejudice. Nothing in this subsection creates an obligation for a Settling State to make a monetary payment or incur any other obligation to an entity filing a lawsuit.

B. *Non-Settling States.* Non-Settling States shall not be eligible for any payments or have any rights in connection with this Agreement.

C. *Settlement Class Resolution Opt Outs.* If a Settling State is eligible for Incentive Payment A on the basis of a Settlement Class Resolution, and a Primary Subdivision that opted out of the Settlement Class Resolution maintains a lawsuit asserting a Released Claim against a Released Entity, the Released Entity shall take ordinary and reasonable measures to defend the action, including filing a Threshold Motion with respect to the Released Claim. The Settling State shall seek to obtain either dismissal of the lawsuit in cooperation with Walmart, or a release of the Primary Subdivision's claims.

D. *Revoked Bar, Settlement Class Resolution, or Case-Specific Resolution.* If a Settling State received any Payout Amounts that included any incentive payments earned as a result of the existence of a Bar, Settlement Class Resolution, or Case-Specific Resolution in a Settling State, and there is subsequently a Revocation Event with respect to that Bar, Settlement Class Resolution, or Case-Specific Resolution after the determination of the amount of such Payout Amount, that Settling State shall seek to obtain a release of the claims impacted by the Revocation Event, including but not limited to defending the legality of the Bar, obtaining a dismissal of the claims made against the Released Entity, and obtaining releases from impacted Subdivisions.

## **XII. Miscellaneous**

A. *Population of General-Purpose Governments.* The population figures for General-Purpose Governments shall be the published U.S. Census Bureau's population estimates for July 1, 2019, released May 2020. These population figures shall remain unchanged during the term of this Agreement.<sup>12</sup>

B. *Population of Special Districts.* For any purpose in this Agreement in which the population of a Special District is used other than Section IV.E.1.a and Section IV.E.3.b: (a) School Districts' populations will be measured by the number of students enrolled who are eligible under the Individuals with Disabilities Education Act ("*IDEA*") or Section 504 of the Rehabilitation Act of 1973; (b) Health Districts' and Hospital Districts' populations will be measured at twenty-five percent (25%) of discharges; and (c) all other Special Districts' (including fire districts' and library districts') populations will be measured at ten percent (10%) of the population served. For the avoidance of doubt, this means that California healthcare districts will be measured at ten percent (10%) of their membership. Walmart and the Enforcement Committee shall meet and confer in order to agree on data sources for purposes of this Section XII.B prior to the State Participation Date.

---

<sup>12</sup> The estimates for counties and parishes were accessed at <https://www.census.gov/data/datasets/time-series/demo/popest/2010s-countiestotal.html>. The estimates for cities and towns can currently be found at <https://www.census.gov/data/datasets/time-series/demo/popest/2010s-total-cities-and-towns.html>.

C. *Population Associated with Sheriffs.* For any purpose in this Agreement in which the population associated with a lawsuit by a sheriff is used, the population will be measured at twenty percent (20%) of the capacity of the jail(s) operated by the sheriff.

D. *No Admission.* The Parties intend the settlement as described herein to be a final and complete resolution of all disputes between Walmart and all Releasors. Walmart is entering into this Agreement solely for the purposes of settlement, to resolve all Actions and Released Claims and thereby avoid significant expense, inconvenience and uncertainty. Walmart denies the allegations in the Actions and denies any civil or criminal liability in the Actions. Nothing contained herein may be taken as or deemed to be an admission or concession by Walmart of: (i) any violation of any law, regulation, or ordinance; (ii) any fault, liability, or wrongdoing; (iii) the strength or weakness of any Claim or defense or allegation made in any Action, or in any other past, present or future proceeding relating to any Covered Conduct, Alleged Harms, or any Product; (iv) the legal viability of the Claims and theories in any Action, including but not limited to the legal viability of the relief sought; or (v) any other matter of fact or law. Nothing in this Agreement shall be construed or used to prohibit any Released Entity from engaging in the conduct of its business relating to any Product in accordance with the Injunctive Relief Terms and applicable laws and regulations.

E. *Most-Favored-Nation Provision.*

1. If, after the Effective Date, Walmart enters into any settlement agreement with any Non-Settling State that resolves Claims similar in scope to the Claims released by a Settling State under this Agreement on overall payment terms that are more favorable to such Non-Settling State than the overall payment terms of the Agreement (after due consideration of relevant differences in population or other appropriate factors), then the Settling States may elect to seek review, pursuant to Section XII.E.3, of the overall payment terms of this Agreement and the Non-Settling State agreement so that such Settling State(s) may obtain, with respect to Walmart, overall payment terms at least as favorable as those obtained by such Non-Settling State. “*Overall payment terms*” refers to consideration of all payment terms of the two agreements, taken together, including, but not limited to the amounts of payments, the timing of payments, and conditions or contingencies on payments.

2. For any settlement with a Non-Settling State involving Released Claims that is entered into after the Effective Date, Walmart shall provide the Enforcement Committee with a copy of the settlement agreement or relevant consent judgment within thirty (30) calendar days of the consummation of such settlement. The Enforcement Committee will promptly distribute such copy to all Settling States.

3. In the event that one or more Settling State(s) believes that the overall payment terms of an agreement by Walmart with a Non-Settling State are more favorable to the Non-Settling State, based on the totality of the considerations set forth in Section XII.E.1, the Settling State(s) and Walmart shall engage in the following process:

a. The Settling State(s) shall provide notice, within sixty (60) calendar days of the date on which the Enforcement Committee provides a settlement

agreement or consent judgment to Walmart of their intent to seek revision of this Agreement to provide payment terms that are, on an overall basis, as favorable as those obtained by the Non-Settling State. To the extent allowed by law, such notice shall be confidential and not disclosed publicly and shall provide, in detail, the basis for the State's belief that it is entitled to a revision of the Agreement.

b. Walmart shall, within thirty (30) calendar days, provide a response to the Settling State(s), explaining its position, in detail, as to whether the Settling State(s) are entitled to more favorable overall payment terms than those provided for in this Agreement.

c. In the event the Settling State(s) and Walmart do not reach agreement as to the application of Section XII.E.1, the Settling State(s) may petition the National Arbitration Panel to seek a ruling from the Panel as to the applicability of Section XII.E.1, provided that the Settling State(s) may seek such review only if at least five (5) Settling States co-sign the petition. The Panel shall consider submissions and argument by the parties pursuant to the procedures set forth in Section VI.F.3.

d. The Settling State and Walmart shall be bound by the determination of the National Arbitration Panel.

4. This Section XII.E does not apply to, and there is no ability of any Settling State to seek or obtain revision of this Agreement based on, any Non-Settling State agreement with Walmart that is entered into with: (a) a Non-Settling State after a date ninety (90) calendar days prior to the scheduled start date of a trial between Walmart and the Non-Settling State or any severed or bifurcated portion thereof, provided that, where, in order to complete a settlement, a Non-Settling State and Walmart jointly request an adjournment of the scheduled start date of a trial within ninety (90) days of that date, this exception will apply as if the trial date had not been adjourned; (b) a Non-Settling State that previously litigated to judgment a case related to opioids against any manufacturer, distributor, or pharmacy; or (c) a Non-Settling State that has obtained any court order or judicial determination that grants judgment (in whole or in part) against Walmart. For avoidance of doubt, the National Arbitration Panel shall have no power to review agreements described in this paragraph.

5. This Section XII.E does not apply to, and there is no ability of any Settling State to seek or obtain revision of this Agreement based on, any agreement between Walmart and Non-Participating Subdivisions.

6. This Section XII.E will not apply to any agreement entered into more than eighteen (18) months after the Effective Date.

F. *Tax Cooperation and Reporting.*

1. Upon request by Walmart, the Settling States and Participating Subdivisions agree to perform such further acts and to execute and deliver such further documents as may be reasonably necessary for Walmart to establish the statements set forth in Section

V.F to the satisfaction of their tax advisors, their independent financial auditors, the Internal Revenue Service, or any other governmental authority, including as contemplated by Treasury Regulations Section 1.162-21(b)(3)(ii) and any subsequently proposed or finalized relevant regulations or administrative guidance.

2. Without limiting the generality of Section XII.F.1, each Settling State and Participating Subdivision shall cooperate in good faith with Walmart with respect to any tax claim, dispute, investigation, audit, examination, contest, litigation, or other proceeding relating to this Agreement.

3. The Designated State, on behalf of all Settling States and Participating Subdivisions, shall designate one of its officers or employees to act as the “appropriate official” within the meaning of Treasury Regulations Section 1.6050X-1(f)(1)(ii)(B) (the “*Appropriate Official*”). The Designated State shall direct and ensure that the Appropriate Official timely (a) files (i) at the time this Agreement becomes binding on the Parties, an IRS Form 1098-F in the form attached as Exhibit U with respect to Walmart and (ii) any legally required returns or amended returns with any applicable governmental authority, or any returns requested by Walmart, and (b) provides to Walmart a copy of (i) the IRS Form 1098-F filed with respect to Walmart and (ii) any legally required written statement pursuant to any applicable law and any other document referred to in clause (a)(ii) above. Any such form, return, or statement shall be prepared and filed in a manner fully consistent with Section V.F.

4. Any return, amended return, or written statement filed or provided pursuant to Section XII.F.3, and any similar document, shall be prepared and filed in a manner consistent with reporting the Global Settlement Amount as the “Total amount to be paid” pursuant to this Agreement in Box 1 of IRS Form 1098-F and the Total Remediation Amount as “Restitution/remediation amount” in Box 2 of IRS Form 1098-F, as reflected in the attached Exhibit U. If the Designated State or Appropriate Official shall be required to file any return, amended return, or written statement contemplated by this Section XII.F other than an IRS Form 1098-F in the form attached as Exhibit U, the Designated State shall direct and ensure that the Appropriate Official provides to Walmart a draft of such return, amended return, or written statement no later than sixty (60) calendar days prior to the due date thereof, and shall accept any reasonable revisions from Walmart on the return, amended return, or written statement.

5. For the avoidance of doubt, neither Walmart nor the Settling States and Participating Subdivisions make any warranty or representation to any Settling State, Participating Subdivision, or Releasor as to the tax consequences of the payment of the Total Remediation Amount (or any portion thereof).

G. *No Third-Party Beneficiaries.* Except as expressly provided in this Agreement, no portion of this Agreement shall provide any rights to, or be enforceable by, any person or entity that is not a Settling State or Released Entity. No Settling State may assign or otherwise convey any right to enforce any provision of this Agreement.

H. *Calculation.* Any figure or percentage referred to in this Agreement shall be carried to seven decimal places.

I. *Construction.* None of the Parties and no Participating Subdivision shall be considered to be the drafter of this Agreement or of any of its provisions for the purpose of any statute, case law, or rule of interpretation or construction that would or might cause any provision to be construed against the drafter of this Agreement. The headings of the provisions of this Agreement are not binding and are for reference only and do not affect the meaning of this Agreement.

J. *Cooperation.* Each Party and each Participating Subdivision agrees to use reasonable efforts and to cooperate with the other Parties and Participating Subdivisions to cause this Agreement and Consent Judgments to become effective, to obtain all necessary approvals, consents and authorizations, if any, and to execute all documents and to take such other action as may be appropriate in connection herewith. Consistent with the foregoing, each Party and each Participating Subdivision agrees that it will not directly or indirectly assist or encourage any challenge to this Agreement or any Consent Judgment by any other person, and will support the integrity and enforcement of the terms of this Agreement and the Consent Judgments.

K. *Entire Agreement.* This Agreement, including its exhibits and any other attachments, embodies the entire agreement and understanding between and among the Parties and Participating Subdivisions relating to the subject matter hereof and supersedes (1) all prior agreements and understandings relating to such subject matter, whether written or oral and (2) all purportedly contemporaneous oral agreements and understandings relating to such subject matter.

L. *Execution.* This Agreement may be executed in counterparts and by different signatories on separate counterparts, each of which shall be deemed an original, but all of which shall together be one and the same Agreement. One or more counterparts of this Agreement may be delivered by facsimile or electronic transmission with the intent that it or they shall constitute an original counterpart hereof. One or more counterparts of this Agreement may be signed by electronic signature.

M. *Good Faith and Voluntary Entry.* Each Party warrants and represents that it negotiated the terms of this Agreement in good faith. Each of the Parties and Participating Subdivisions warrants and represents that it freely and voluntarily entered into this Agreement without any degree of duress or compulsion. The Parties and Participating Subdivisions state that no promise of any kind or nature whatsoever (other than the written terms of this Agreement) was made to them to induce them to enter into this Agreement.

N. *Legal Obligations.* Nothing in this Agreement shall relieve Walmart of the obligation to comply with all state and federal laws, regulations or rules, nor does any provision herein permit any acts or practices prohibited by such laws, regulations, or rules. Except with respect to the Injunctive Relief Terms, in the event of a conflict between this Agreement and any requirement or requirements of federal, state, or local laws, such that Walmart cannot comply with this Agreement without violating such a requirement or requirements, Walmart shall document such conflicts and notify the Attorney(s) General of the relevant Settling State(s) that it intends to comply with the requirement or requirements to the extent necessary to eliminate the conflict.

With respect to the Injunctive Relief Terms, in the event of such a conflict, the procedures set forth in Exhibit P at § I(4)(c) of the Injunctive Relief Terms will be followed.

O. *No Prevailing Party.* The Parties and Participating Subdivisions each agree that they are not the prevailing party in this action, for purposes of any claim for fees, costs, or expenses as prevailing parties arising under common law or under the terms of any statute, because the Parties and Participating Subdivisions have reached a good faith settlement. The Parties and Participating Subdivisions each further waive any right to challenge or contest the validity of this Agreement on any ground, including, without limitation, that any term is unconstitutional or is preempted by, or in conflict with, any current or future law. Nothing in the previous sentence shall modify, or be construed to conflict with, Section XII.N.

P. *Non-Admissibility.* Neither this Agreement nor any act performed or document executed pursuant to or in furtherance of this Agreement: (i) is or may be deemed to be or may be used as an admission or evidence relating to any matter of fact or law alleged in the Actions, the strength or weakness of any Claim or defense or allegation made in those cases, or any wrongdoing, fault, or liability of any Released Entities; or (ii) is or may be deemed to be or may be used as an admission or evidence relating to any liability, fault or omission of Released Entities in any civil, criminal or administrative proceeding in any court, administrative agency or other tribunal. Neither this Agreement nor any act performed or document executed pursuant to or in furtherance of this Agreement shall be admissible in any proceeding for any purpose, except to enforce the terms of this Agreement, and except that Released Entities may file or use this Agreement in any action (1) involving a determination regarding insurance coverage; (2) involving a determination of the taxable income or tax liability of any Released Entities; (3) to support a defense or counterclaim based on principles of res judicata, collateral estoppel, release, good-faith settlement, judgment bar or reduction or on any other theory of claim preclusion or issue preclusion or similar defense or counterclaim; (4) to support a Claim for contribution and/or indemnification; or (5) to support any other argument or defense by a Released Entities that the Remediation Payment provides a measure of compensation for Alleged Harms or otherwise satisfy the relief sought.

Q. *Notices.* All notices or other communications under this Agreement shall be in writing (including, but not limited to, electronic communications) and shall be given to the recipients indicated below:

For the Attorney(s) General:

Josh Stein, Attorney General  
North Carolina Department of Justice  
Attn: Daniel Mosteller, Deputy General Counsel  
PO Box 629  
Raleigh, NC 27602  
Dmosteller@ncdoj.gov

Dave Yost, Attorney General  
Ohio Attorney's General Office  
Attn: Jonathan Blanton, First Assistant Attorney General

30 East Broad Street  
Columbus, OH 43215  
Jonathan.Blanton@OhioAGO.gov

Letitia James, Attorney General  
New York State Office of the Attorney General  
Attn: Jennifer Levy, First Deputy Attorney General  
28 Liberty Street  
New York, NY 10005  
Jennifer.Levy@ag.ny.gov

For the Plaintiffs' Executive Committee:

Paul T. Farrell, Jr.  
Farrell & Fuller, LLP  
270 Munoz Rivera Ave., Suite 201  
San Juan, Puerto Rico 00918  
paul@farrellfuller.com

Jayne Conroy  
Simmons Hanly Conroy LLC  
112 Madison Avenue, 7th Floor  
New York, NY 10016-7416  
JConroy@simmonsfirm.com

Joseph F. Rice  
Motley Rice LLC  
28 Bridgeside Blvd.  
Mount Pleasant, SC 29464  
jrice@motleyrice.com

For Walmart:

Karen Roberts  
Executive Vice President and General Counsel  
Walmart, Inc.  
702 S.W. 8<sup>th</sup> Street  
Bentonville, AR 72716  
Karen.Roberts@walmartlegal.com

Notices to Walmart's attorneys shall be delivered to:

David W. Ogden  
Charles C. Speth  
Wilmer Cutler Pickering Hale and Dorr LLP  
1875 Pennsylvania Avenue, NW  
Washington, DC 20006



David.Ogden@wilmerhale.com  
Charles.Speth@wilmerhale.com

Brian K. Mahanna  
Wilmer Cutler Pickering Hale and Dorr LLP  
7 World Trade Center  
250 Greenwich Street  
New York, NY 10007  
Brian.Mahanna@wilmerhale.com

Any Party or the Plaintiffs' Executive Committee may change or add the contact information of the persons designated to receive notice on its behalf by notice given (effective upon the giving of such notice) as provided in this Section XII.Q.

R. *No Waiver.* The waiver of any rights conferred hereunder shall be effective only if made by written instrument executed by the waiving Party or Parties. The waiver by any Party of any breach of this Agreement shall not be deemed to be or construed as a waiver of any other breach, whether prior, subsequent, or contemporaneous, nor shall such waiver be deemed to be or construed as a waiver by any other Party.

S. *Severability.* In the event any one or more immaterial provisions of this Agreement shall for any reason be held to be invalid, illegal or unenforceable in any respect, such invalidity, illegality or unenforceability shall not affect any other provision of this Agreement.

T. *Preservation of Privilege.* Nothing contained in this Agreement or any Consent Judgment, and no act required to be performed pursuant to this Agreement or any Consent Judgment, is intended to constitute, cause, or effect any waiver (in whole or in part) of any attorney-client privilege, work product protection, or common interest/joint defense privilege, and each Party and Participating Subdivision agrees that it shall not make or cause to be made in any forum any assertion to the contrary.

U. *Successors.*

1. This Agreement shall be binding upon, and inure to the benefit of, Walmart and its respective successors and assigns.

2. Walmart shall not sell the majority of its voting stock or substantially all its assets without obtaining the acquiror's agreement that it will constitute a successor with respect to Walmart's obligations under this Agreement.

3. Walmart shall not in one (1) transaction, or a series of related transactions, sell, or transfer assets (other than sales or transfers of inventories, or sales or transfers to an entity owed directly or indirectly by Walmart) having a fair market value equal to twenty-five percent (25%) or more of the consolidated assets of Walmart where the sale or transfer transaction is announced after the Effective Date, is not for fair consideration, and would foreseeably and unreasonably jeopardize Walmart's ability to make the payments under this Agreement that are due on or before the third Payment Date following the close

of a sale or transfer transaction. The above restriction shall not apply if Walmart obtains the acquiror's agreement that it will be either a guarantor of or successor to the percentage of Walmart's remaining payment obligations under this Agreement equal to the percentage of Walmart's consolidated assets being sold or transferred in such transaction. Percentages under this section shall be determined in accordance with the United States generally accepted accounting principles and as of the date of Walmart's most recent publicly filed consolidated balance sheet prior to the date of entry into the sale or transfer agreement at issue. This Section XII.U.3 shall be enforceable solely by the Enforcement Committee, and any objection under this Section XII.U.3 not raised within twenty (20) calendar days from the date that Walmart transmits notice of the transaction to the Enforcement Committee is waived. Any dispute under this Section XII.U.3 shall be a National Dispute as described in Section VI.F.3 and must be raised exclusively with the National Arbitration Panel as described therein within twenty (20) calendar days of the announcement, and the sole remedy shall be an order enjoining the transaction.

4. The restrictions set forth in Sections XII.U.2-3 shall expire sixty (60) days after Walmart satisfies the payment terms in Section IV.B.

V. *Waiver.* Walmart, for good and valuable consideration the receipt of which is acknowledged, hereby (a) waives, foregoes and relinquishes all rights to utilize and/or seek relief under any of the following laws of the State of Texas for the restructuring of its debts or liabilities related to Released Claims, Claims that would have been Released Claims if they had been brought by a Releasor against a Released Entity before the Effective Date, or this Agreement: Tex. Bus. Orgs. Code § 10.003 (Contents of Plan of Merger: More Than One Successor) or any other statute of Subchapter A of Chapter 10 of Tex. Bus. Orgs. Code to the extent such statute relates to multi-successor mergers (and/or any other similar laws or statutes in any other state or territory); Tex. Bus. Orgs. Code §§ 11.01–11.414 (Winding Up and Termination of Domestic Entity); or Tex. Bus. & Com. Code §§ 23.01–23.33 (Assignments for the Benefit of Creditors) (collectively, the “Texas Statutes”), and (b) agrees, warrants and represents that it will not file, request or petition for relief under the Texas Statutes related to its debts or liabilities related to Released Claims, Claims that would have been Released Claims if they had been brought by a Releasor against a Released Entity before the Effective Date, or this Agreement, in each case until ninety (90) days after Walmart satisfies the payment terms in Section IV.B. The foregoing waiver and relinquishment includes, without limitation, until ninety (90) days after Walmart satisfies the payment terms in Section IV.B, Walmart's rights to execute a divisional merger or equivalent transaction or restructuring related to its debts or liabilities related to Released Claims, Claims that would have been Released Claims if they had been brought by a Releasor against a Released Entity before the Effective Date, or this Agreement that in each case has the intent or foreseeable effect of (i) separating material assets from material liabilities and (ii) assigning or allocating all or a substantial portion of those liabilities to any subsidiary or affiliate that files for relief under chapter 11 of the Bankruptcy Code, or pursuant to which such subsidiary or affiliate that files for relief under chapter 11 of the Bankruptcy Code would be assuming or retaining all or a substantial portion of those liabilities.

W. *Modification, Amendment, Alteration.* In the event the Plaintiffs' Executive Committee, the Executive Committee of the State Attorneys General, or Walmart concludes prior to December 1, 2022 that technical corrections are required to this Agreement, the Plaintiffs' Executive Committee, the Executive Committee of the State Attorneys General, and Walmart shall

meet and confer and make such amendments as they agree are appropriate. Except as otherwise provided in this Agreement, after the State Participation Date, any modification, amendment, or alteration of this Agreement by the Parties shall be binding only if evidenced in writing signed by Walmart, along with the signatures of at least two-thirds of the Settling States along with a representation from each such Settling State that either: (1) the Advisory Committee or similar entity established or recognized by that Settling State (either pursuant to Section V.E.2.d, by a State-Subdivision Agreement, or by statute) voted in favor of the modification, amendment or alteration of this Agreement including at least one member appointed by the Participating Subdivisions; or (2) in States without any Advisory Committee, that 50.1% (by population) of the Participating Subdivisions expressed approval of the modification, amendment, or alteration of this Agreement in a writing.

X. *Termination.*

1. Unless otherwise agreed to by Walmart and the Settling State in question, this Agreement or the Consent Judgment as to that Settling State and all of its terms (except Section XII.P and any other non-admissibility provisions, which shall continue in full force and effect) shall be canceled and terminated with respect to the Settling State, and the Agreement and all orders issued by the courts in the Settling State pursuant to the Agreement shall become null and void and of no effect, only if one or more of the following conditions applies:

a. a Consent Judgment approving this Agreement without modification of any of the Agreement's terms has not been entered as to the Settling State by a court of competent jurisdiction on or before one hundred eighty (180) days after the Effective Date; or

b. this Agreement has been disapproved by a court of competent jurisdiction to which it was presented for approval and/or entry (or, in the event of an appeal from or review of a decision of such a court to approve this Agreement and the Consent Judgment, by the court hearing such appeal or conducting such review), and the time to appeal from such disapproval has expired, or, in the event of an appeal from such disapproval, the appeal has been dismissed or the disapproval has been affirmed by the court of last resort to which such appeal has been taken and such dismissal or disapproval has become no longer subject to further appeal (including, without limitation, review by the United States Supreme Court).

2. If this Agreement is terminated with respect to a Settling State for whatever reason pursuant to Section XII.X.1, then:

a. an applicable statute of limitation or any similar time requirement (excluding any statute of repose) shall be tolled from the date the Settling State signed this Agreement until the later of the time permitted by applicable law or for one year from the date of such termination, with the effect that Walmart and the Settling State in question shall be in the same position with respect to the statute of limitation as they were at the time the Settling State filed its action; and

b. Walmart and the Settling State in question shall jointly move the relevant court of competent jurisdiction for an order reinstating the actions and claims dismissed pursuant to the terms of this Agreement governing dismissal, with the effect that Walmart and the Settling State in question shall be in the same position with respect to those actions and claims as they were at the time the action or claim was stayed or dismissed.

3. Unless Walmart and the Enforcement Committee agree otherwise, this Agreement, with the exception of the Injunctive Relief Terms that have their own provisions on duration, shall terminate as to all Parties after the Payout Amount in Payment Year 6 is paid, *provided* that Walmart has performed its payment obligations under the Agreement as of that date. Notwithstanding any other provision in this Section XII.X.3 or in this Agreement, all releases under this Agreement will remain effective in perpetuity.

Y. *Governing Law.* Except (1) as otherwise provided in this Agreement or (2) as necessary, in the sole judgment of the National Arbitration Panel, to promote uniformity of interpretation for matters within the scope of the National Arbitration Panel's authority, this Agreement shall be governed by and interpreted in accordance with the respective laws of each Settling State, without regard to the conflict of law rules of such Settling State, that is seeking to enforce the Agreement against Walmart or against which Walmart is seeking enforcement. Notwithstanding any other provision in this subsection on governing law, any disputes relating to the Settlement Fund Escrow shall be governed by and interpreted in accordance with the law of the state where the escrow agent has its primary place of business.

**EXHIBIT A**

**Alleged Harms**

The following expert reports that were filed in connection with the case captioned *In re: National Prescription Opiate Litigation*, No. 1: 17-md-2804 (N.D. Ohio) provide non-exclusive examples of Alleged Harms:

1. Expert report of G. Caleb Alexander, dated April 16, 2021.
2. Expert report of David Cutler, dated April 16, 2021; supplemental expert report of David Cutler, dated April 21, 2021; and second supplemental expert report of David Cutler, dated May 10, 2021.
3. Expert report of David Herzberg, dated April 16, 2021.
4. Expert report of Katherine M. Keyes, Ph.D., dated April 16, 2021; supplemental expert report of Katherine M. Keyes, Ph.D, dated June 2, 2021.
5. Expert report of Dr. Anna Lembke, dated April 16, 2021.
6. Expert report of Harvey Rosen, dated April 16, 2021.
7. Expert report of Nancy Young, dated April 16, 2021.

## **EXHIBIT B**

### **Enforcement Committee Organization Bylaws**

#### **ARTICLE I**

These bylaws constitute the code of rules adopted by the Settling States and Participating Subdivisions for the creation of an Enforcement Committee (the “Committee”) to exist and operate during the term of the Agreement in connection with Walmart and shall control the regulation and management of the Committee’s affairs.

#### **ARTICLE II**

##### **Purpose**

The Committee is organized for the sole purpose of evaluating and taking such action as deemed reasonable, necessary, and appropriate by the members of the Committee on the matters delegated to the Committee under that certain Settlement Agreement between the Settling States and Walmart dated November 14, 2022.

#### **ARTICLE III**

##### **Members of the Committee**

**(1) Number of Members**

The Committee will consist of thirteen (13) members (the “Members”). Upon majority resolution of the Committee, the number of Members may be increased or decreased from time to time, but in no event shall a decrease have the effect of decreasing the total number of Members to less than seven Members.

**(2) Initial Members**

The Committee initially will consist of eight (8) Settling State Members and five (5) Participating Subdivision Members; at least two (2) of the Participating Subdivisions shall be counties and threat least two (2) shall be municipalities. The initial Settling State Members are representatives from: [●]. The initial Participating Subdivision Members are: [●]. Until fifteen (15) months from the Effective Date contained in the Settlement Agreement, the Participating Subdivisions may designate their outside counsel to serve as their representative. After fifteen (15) months from the Effective Date, an employee or official of the Participating Subdivision must be the designated as the representative of the Participating Subdivision.

**(3) Term of Members**

The term of office for Members of the Committee will be until the end of the term of the Settlement Agreement unless and until a Member withdraws or resigns from the Committee.

**(4) Resignation**

Any Member may resign at any time by delivering written notice to the Chairperson of the Committee. Such resignation shall take effect upon receipt or, if later, at the time specified in the notice.

**(5) Removal**

(a) Any Member may be removed without cause, at any time, by a majority of the entire Committee, at a Regular or Special Meeting called for that purpose. Any Member under consideration of removal must first be notified about the consideration by written notice at least five days prior to the meeting at which the vote takes place.

(b) In the event that any Member is not a Settling State or a Participating Subdivision or the Member subsequently becomes a Later Litigating Subdivision, the Member shall be removed immediately without notice or vote of the Committee.

**(6) Vacancies**

In the event of a vacancy, the Members of the same type (Settling State or Participating Subdivision) shall select another Settling State or Participating Subdivision to fill that Member's position.

**(7) Compensation**

Members shall not receive any salaries or other compensation for their services, but, by resolution of the Committee, may be reimbursed for any actual expenses incurred in the performance of their duties for the Committee, as long as a majority of disinterested Members approve the reimbursement. Any reimbursement shall be sought from the Settlement Fund Administrator.

**ARTICLE IV**

**Conflicts of Interest and Code of Ethics**

If a Member, agent, or employee of the Committee has a conflict of interest, he or she may not participate in a vote, discussion, or decision about the matter. Each Member shall follow any applicable state or local law with respect to conflicts, gifts, and ethics.

**ARTICLE V**

**Committee Meetings**

**(1) Place of Meetings**

Meetings of the Committee will be held at any place that the Chairperson may designate, including by telephonic or electronic means.

**(2) Regular Meetings**

Regular meetings of the Committee shall be held as deemed necessary by the Chairperson or any three members.

**(3) Notice of Meetings**

Written notice of the date, time, place and subject of each meeting must be provided to the Members at least 72 hours before the scheduled time of the meeting, except when there is an emergency or urgent public necessity.

**(4) Quorum**

A majority of the incumbent Members (not counting vacancies) shall constitute a quorum for the purposes of convening a meeting or conducting business.

**(5) Voting and Proxy**

When it is necessary to vote on any matter before the Committee, Members may vote by electronic means as provided in these Bylaws. Proxy voting is permitted. In order for a matter to pass, the matter must have a majority vote of Members present and must have at least one vote from a Settling State Member and a Participating Subdivision Member. In the event that there is a Quorum, but no Settling State or Participating Subdivision Member is present, then a matter may pass with a simple majority vote.

**(6) Minutes**

The Committee shall prepare and keep minutes. The minutes must state the subject of each deliberation and indicate each vote, order, decision, or other action taken.

**ARTICLE VI**  
**Officers**

**(1) Roster of Officers**

The Committee shall have a Chairperson, a Vice Chairperson, and a Secretary. The Committee may have at its discretion, such other officers as may be appointed by the Members of the Committee. One person may hold two or more offices, except those serving as Chairperson.

**(2) Election and Removal of Officers**

All officers shall serve two-year terms. The election shall be conducted at the first meeting of the fiscal year. Officers shall remain in office until their successors have been selected. Officers may serve consecutive terms without limit. The election of officers shall be by majority vote of the Members of the Committee attending the meeting.

**(3) Vacancies**

If a vacancy occurs during the term of office for any elected officer, the Members of the Committee shall elect a new officer to fill the remainder of the term as soon as practical, by majority vote of Members present.

**(4) Chairperson**

The Chairperson will supervise and control the affairs of the Committee and shall exercise such supervisory powers as may be given him/her by the Members of the Committee. The Chairperson will perform all duties incident to such office and such other duties as may be provided in these bylaws or as may be prescribed from time to time by the Committee. The Chairperson shall preside at all meetings and shall exercise parliamentary control in accordance with Robert's Rules of Order.

**(5) Vice Chairperson**

The Vice Chairperson shall act in place of the Chairperson in the event of the Chairperson's absence, inability, or refusal to act, and shall exercise and discharge such other duties as may be required by the Committee. The Vice Chairperson shall serve as the parliamentarian and interpret any ambiguities of the bylaws.



- (6) **Secretary**  
The Secretary will keep and maintain all records related to the Committee and take minutes of all meetings.
- (7) **Records**  
All elected officers and committee chairpersons shall relinquish their records to the Chairperson immediately upon the completion of their term of office or completion of a project.
- (8) **Resignation**  
An officer may resign the office while not resigning membership from the Committee, by submitting a letter to the Chairperson. Vacancies occurring in any office shall be appointed for the remainder of the term.

## **ARTICLE VII**

### **Duties**

- (1) **Prior to the Effective Date**  
The Committee shall be responsible for any additional negotiations with Walmart, including, but not limited to, negotiating extensions of any periods created by the Settlement Agreement, except that any additional negotiations related to the Injunctive Relief Terms (Exhibit P) shall be handled by the States Injunctive Relief Committee in accordance with the terms of Exhibit P.
- (2) **After the Effective Date**  
The Committee shall establish procedures for the receipt of notices that a dispute exists concerning the Agreement and review of such disputes, pursuant to Section [●] of the Agreement. Members may engage with Walmart, Settling States, and Participating Subdivisions attempting to resolve any dispute without further action by the Committee. The Committee may request additional information from Walmart, Settling States, and Participating Subdivisions to the extent the Committee believes such information is necessary to understand, resolve, or provide advice related to a dispute. The Committee shall endeavor to provide advice relative to the dispute no later than 60 days after receipt of notice.

## **ARTICLE VIII**

### **Rules of Procedure**

The proceedings and business of the Committee shall be governed by Robert's Rules of Order unless otherwise waived by the Committee.

## **ARTICLE IX**

### **Operations**

- (1) **Records**  
The Committee will keep correct and complete records and will also keep minutes of the proceedings of the Committee meetings and Committees. The Committee will keep such records at its principal place of business at a place designated by the Chairperson.

All elected officers and committee chairpersons shall relinquish their records to the Chairperson, immediately upon the completion of their term of office.

**(2) Inspection of Books and Records**

The minutes of a meeting are public records and shall be available for public inspection and copying on request to the Committee's Chairperson or the Chairperson's designee.

**(3) Amendments**

The bylaws may be amended at any time by a vote of a majority of Members present and must have at least one vote from a Settling State Member and a Participating Subdivision Member. In the event that there is a Quorum, but no Settling State or Participating Subdivision Member is present, then a matter may pass with a simple majority vote.

## EXHIBIT C

### Litigating Subdivisions Exhibit

- |     |                                  |     |   |
|-----|----------------------------------|-----|---|
| 1.  | Alabaster, City of, Alabama      | 44. | East Brewton, City of, Alabama  |
| 2.  | Albertville, City of, Alabama    | 45. | Elmore, County of, Alabama  |
| 3.  | Arab, City of, Alabama           | 46. | Enterprise, City of, Alabama  |
| 4.  | Ashville, City of, Alabama       | 47. | Fairhope, City of, Alabama  |
| 5.  | Athens, City of, Alabama         | 48. | Fayette, City of, Alabama   |
| 6.  | Attalla, City of, Alabama        | 49. | Fayette, County of, Alabama/<br>Fayette, (Sheriff of) County of,<br>Alabama     |
| 7.  | Auburn, City of, Alabama         | 50. | Florence, City of, Alabama  |
| 8.  | Baldwin, County of, Alabama      | 51. | Foley, City of, Alabama   |
| 9.  | Bay Minette, City of, Alabama    | 52. | Fort Deposit, Town of, Alabama  |
| 10. | Berry, Town of, Alabama          | 53. | Fort Payne, City of, Alabama  |
| 11. | Bessemer, City of, Alabama       | 54. | Fultondale, City of, Alabama  |
| 12. | Bibb, County of, Alabama         | 55. | Gadsden, City of, Alabama   |
| 13. | Birmingham, City of, Alabama     | 56. | Geraldine, Town of, Alabama   |
| 14. | Boaz, City of, Alabama           | 57. | Gilbertown, Town of, Alabama  |
| 15. | Brewton, City of, Alabama        | 58. | Grant, Town of, Alabama   |
| 16. | Bridgeport, City of, Alabama     | 59. | Graysville, City of, Alabama  |
| 17. | Brookwood, Town of, Alabama      | 60. | Guin, City of, Alabama  |
| 18. | Butler, Town of, Alabama         | 61. | Gulf Shores, City of, Alabama   |
| 19. | Calera, City of, Alabama         | 62. | Guntersville, City of, Alabama  |
| 20. | Calhoun, County of, Alabama      | 63. | Haleyville, City of, Alabama  |
| 21. | Camp Hill, Town of, Alabama      | 64. | Hamilton, City of, Alabama  |
| 22. | Carbon Hill, City of, Alabama    | 65. | Hartselle, City of, Alabama   |
| 23. | Cedar Bluff, Town of, Alabama    | 66. | Helena, City of, Alabama  |
| 24. | Centre, City of, Alabama         | 67. | Henagar, City of, Alabama   |
| 25. | Centreville, City of, Alabama    | 68. | Homewood, City of, Alabama  |
| 26. | Cherokee, County of, Alabama     | 69. | Hueytown, City of, Alabama  |
| 27. | Cherokee, Town of, Alabama       | 70. | Huntsville, City of, Alabama  |
| 28. | Childersburg, City of, Alabama   | 71. | Irondale, City of, Alabama  |
| 29. | Chilton, County of, Alabama      | 72. | Jackson, County of, Alabama   |
| 30. | Clanton, City of, Alabama        | 73. | Jacksonville, City of, Alabama  |
| 31. | Coffee, County of, Alabama       | 74. | Jasper, City of, Alabama  |
| 32. | Columbiana, City of, Alabama     | 75. | Jefferson, County of, Alabama/<br>Jefferson, (Sheriff of) County of,<br>Alabama |
| 33. | Cordova, City of, Alabama        | 76. | Jefferson County Board of Health,<br>Alabama                                    |
| 34. | Cullman, City of, Alabama        | 77. | Lamar, County of, Alabama/<br>Lamar, (Sheriff of) County of, Alabama            |
| 35. | Cullman, County of, Alabama      | 78. | Lauderdale, County of, Alabama  |
| 36. | Dadeville, City of, Alabama      | 79. | Lawrence, County of, Alabama  |
| 37. | Dallas, County of, Alabama       | 80. | Leesburg, City of, Alabama  |
| 38. | Daphne, City of, Alabama         |     |   |
| 39. | Decatur, City of, Alabama        |     |   |
| 40. | Demopolis, City of, Alabama      |     |   |
| 41. | Dora, City of, Alabama           |     |   |
| 42. | Double Springs, Town of, Alabama |     |   |
| 43. | Douglas, Town of, Alabama        |     |   |

81. Lincoln, City of, Alabama
82. Loxley, Town of, Alabama
83. Madison, County of, Alabama
84. Marengo, County of, Alabama
85. Marion, County of, Alabama
86. Marshall, County of, Alabama
87. Millbrook, City of, Alabama
88. Mobile, City of, Alabama
89. Mobile, County of, Alabama
90. Moody, City of, Alabama
91. Morgan, County of, Alabama
92. Moulton, City of, Alabama
93. Mountain Brook, City of, Alabama
94. Munford, Town of, Alabama
95. Nauvoo, Town of, Alabama
96. New Hope, City of, Alabama
97. Northport, City of, Alabama
98. Oakman, City of, Alabama
99. Oakman, Town of, Alabama
100. Opelika, City of, Alabama
101. Opp, City of, Alabama
102. Ozark, City of, Alabama
103. Parrish, City of, Alabama
104. Pelham, City of, Alabama
105. Phenix City, City of, Alabama
106. Pickens, County of, Alabama
107. Piedmont, City of, Alabama
108. Pike, County of, Alabama
109. Pleasant Grove, City of, Alabama
110. Prichard, City of, Alabama
111. Ragland, Town of, Alabama
112. Rainbow City, City of, Alabama
113. Randolph, County of, Alabama
114. Roanoke, City of, Alabama
115. Robertsdale, City of, Alabama
116. Saraland, City of, Alabama
117. Scottsboro, City of, Alabama
118. Selma, City of, Alabama
119. Semmes, City of, Alabama
120. Sipsy, Town of, Alabama
121. Slocumb, City of, Alabama
122. Spanish Fort, City of, Alabama
123. Springville, City of, Alabama
124. Sumiton, City of, Alabama
125. Summerdale, Town of, Alabama
126. Sylacauga, City of, Alabama
127. Talladega, County of, Alabama
128. Tallapoosa, County of, Alabama
129. Thomasville, City of, Alabama
130. Troy, City of, Alabama
131. Trussville, City of, Alabama
132. Tuscaloosa, County of, Alabama
133. Vernon, City of, Alabama
134. Vestavia Hills, City of, Alabama
135. Walker, County of, Alabama
136. West Blocton, Town of, Alabama
137. Wetumpka, City of, Alabama
138. Winfield, City of, Alabama
139. Winston, County of, Alabama
140. Woodville, Town of, Alabama
141. Arizona Municipal Risk Retention Pool, Arizona
142. Conchise, County of, Arizona
143. Kingman, City of, Arizona
144. Maricopa, County of, Arizona
145. Mohave, County of, Arizona
146. Phoenix, City of, Arizona
147. Pinal, County of, Arizona
148. Prescott, City of, Arizona
149. Yuma, County of, Arizona
150. Jefferson, County of, Arkansas
151. Pulaski, County of, Arkansas
152. Amador, County of, California
153. Board of Education of the Pleasant Valley School District, California
154. Butte, County of, California
155. Calaveras, County of, California
156. Chico, City of, California
157. Chula Vista, City of, California
158. Clearlake, City of, California
159. Del Norte, County of, California
160. El Dorado, County of, California
161. Fresno, County of, California
162. Huntington Beach, City of, California
163. Imperial, County of, California
164. Inyo, County of, California
165. Laguna Beach, City of, California
166. Lakeport, City of, California
167. Lassen, County of, California
168. Lassen County Office of Education, California

- |      |   |      |                                     |
|------|---|------|-------------------------------------|
| 169. | Madera, County of, California   | 208. | Pueblo, County of, Colorado         |
| 170. | Mariposa, County of, California   | 209. | Sheridan, City of, Colorado         |
| 171. | Mendocino, County of, California  | 210. | Thornton, City of, Colorado         |
| 172. | Merced, County of, California   | 211. | Beacon Falls, Town of, Connecticut  |
| 173. | Modoc, County of, California  | 212. | Berlin, Town of, Connecticut        |
| 174. | Mono, County of, California   | 213. | Bethlehem, Town of, Connecticut     |
| 175. | Monterey, County of, California   | 214. | Bridgeport, City of, Connecticut    |
| 176. | Nevada, County of, California   | 215. | Bristol, City of, Connecticut       |
| 177. | Placer, County of, California   | 216. | Coventry, Town of, Connecticut      |
| 178. | Plumas, County of, California   | 217. | East Hartford, Town of, Connecticut |
| 179. | Riverside, County of, California  | 218. | Enfield, Town of, Connecticut       |
| 180. | Sacramento, County of, California   | 219. | Fairfield, Town of, Connecticut     |
| 181. | San Bernardino, County of,<br>California  | 220. | Middlebury, Town of, Connecticut    |
| 182. | San Diego, County of, California  | 221. | Middletown, City of, Connecticut    |
| 183. | San Jose, City of, California   | 222. | Milford, City of, Connecticut       |
| 184. | San Leandro Unified School District,<br>California  | 223. | Monroe, City of, Connecticut        |
| 185. | San Luis Obispo, County of,<br>California   | 224. | Naugatuck, Borough of, Connecticut  |
| 186. | Santa Clara, County of, California/<br>Santa Clara, (District Attorney of)<br>County of, California | 225. | New Milford, Town of, Connecticut   |
| 187. | Shasta, County of, California   | 226. | Newtown, Town of, Connecticut       |
| 188. | Siskiyou, County of, California   | 227. | North Haven, Town of, Connecticut   |
| 189. | Susanville Elementary School<br>District, California  | 228. | Norwich, City of, Connecticut       |
| 190. | Sutter, County of, California   | 229. | Oxford, Town of, Connecticut        |
| 191. | Tehama, County of, California   | 230. | Prospect, Town of, Connecticut      |
| 192. | Trinity, County of, California  | 231. | Roxbury, Town of, Connecticut       |
| 193. | Tulare, County of, California   | 232. | Seymour, Town of, Connecticut       |
| 194. | Tuolumne, County of, California   | 233. | Sheldon, City of, Connecticut       |
| 195. | Yolo, County of, California   | 234. | Southbury, Town of, Connecticut     |
| 196. | Yuba, County of, California   | 235. | Southington, Town of, Connecticut   |
| 197. | Alamosa, City of/ Town of,<br>Colorado  | 236. | Stratford, Town of, Connecticut     |
| 198. | Alamosa, County of, Colorado  | 237. | Thomaston, Town of, Connecticut     |
| 199. | Brighton, City of, Colorado   | 238. | Tolland, Town of, Connecticut       |
| 200. | Chaffee, County of, Colorado  | 239. | Torrington, City of, Connecticut    |
| 201. | Conejos, County of, Colorado  | 240. | Waterbury, City of, Connecticut     |
| 202. | Federal Heights, City of, Colorado  | 241. | West Haven, City of, Connecticut    |
| 203. | Greeley, City of, Colorado  | 242. | Wethersfield, Town of, Connecticut  |
| 204. | Lakewood, City of, Colorado   | 243. | Windham, Town of, Connecticut       |
| 205. | Las Animas, County of, Colorado   | 244. | Wolcott, Town of, Connecticut       |
| 206. | Mesa, County of, Colorado   | 245. | Woodbury, Town of, Connecticut      |
| 207. | Otero, County of, Colorado  | 246. | Sussex, County of, Delaware         |
|      |   | 247. | Alachua, County of, Florida         |
|      |   | 248. | Apopka, City of, Florida            |
|      |   | 249. | Bay, County of, Florida             |
|      |   | 250. | Bradenton, City of, Florida         |
|      |   | 251. | Bradford, County of, Florida        |
|      |   | 252. | Brevard, County of, Florida         |
|      |   | 253. | Broward, County of, Florida         |

- 254. Clay, County of, Florida
- 255. Clearwater, City of, Florida
- 256. Coconut Creek, City of, Florida
- 257. Coral Springs, City of, Florida
- 258. Daytona Beach, City of, Florida
- 259. Daytona Beach Shores, City of, Florida
- 260. Deerfield Beach, City of, Florida
- 261. Deltona, City of, Florida
- 262. Dixie, County of, Florida
- 263. Eatonville, Town of, Florida
- 264. Escambia, County of, Florida
- 265. Florida City, City of, Florida
- 266. Fort Lauderdale, City of, Florida
- 267. Fort Pierce, City of, Florida
- 268. Gilchrist, County of, Florida
- 269. Hallandale Beach, City of, Florida
- 270. Hamilton, County of, Florida
- 271. Homestead, City of, Florida
- 272. Jackson, County of, Florida
- 273. Lake, County of, Florida
- 274. Lauderhill, City of, Florida
- 275. Lee, County of, Florida
- 276. Leon, County of, Florida
- 277. Levy, County of, Florida
- 278. Lynn Haven, City of, Florida
- 279. Manatee, County of, Florida
- 280. Marion, County of, Florida
- 281. Miami Gardens, City of, Florida
- 282. Miami-Dade, County of, Florida
- 283. Miami-Dade County School Board, Florida
- 284. Miramar, City of, Florida
- 285. Monroe, County of, Florida
- 286. New Port Richey, City of, Florida
- 287. Niceville, City of, Florida
- 288. North Miami, City of, Florida
- 289. Ocala, City of, Florida
- 290. Ocoee, City of, Florida
- 291. Okaloosa, County of, Florida
- 292. Orange, County of, Florida
- 293. Orlando, City of, Florida
- 294. Ormond Beach, City of, Florida
- 295. Osceola, County of, Florida
- 296. Oviedo, City of, Florida
- 297. Palatka, City of, Florida
- 298. Palm Bay, City of, Florida
- 299. Palm Beach, County of, Florida
- 300. Palmetto, City of, Florida
- 301. Panama City, City of, Florida
- 302. Pasco, County of, Florida
- 303. Pembroke Pines, City of, Florida
- 304. Pensacola, City of, Florida
- 305. Pinellas, County of, Florida
- 306. Pinellas Park, City of, Florida
- 307. Pompano Beach, City of, Florida
- 308. Port St. Lucie, City of, Florida
- 309. Putnam, County of, Florida
- 310. Putnam County School Board, Florida
- 311. Sanford, City of, Florida
- 312. Santa Rosa, County of, Florida
- 313. Sarasota, City of, Florida
- 314. Seminole, County of, Florida
- 315. St. Augustine, City of, Florida
- 316. St. Johns, County of, Florida
- 317. St. Lucie, County of, Florida
- 318. St. Petersburg, City of, Florida
- 319. Suwannee, County of, Florida
- 320. Sweetwater, City of, Florida
- 321. Tallahassee, City of, Florida
- 322. Taylor, County of, Florida
- 323. Union, County of, Florida
- 324. Volusia, County of, Florida
- 325. Walton, County of, Florida
- 326. Albany, City of, Georgia
- 327. Appling, County of, Georgia/  
Appling, (Sheriff of) County of, Georgia
- 328. Athens-Clarke County, Unified Government of, Georgia
- 329. Atlanta, City of, Georgia
- 330. Augusta, City of, Georgia
- 331. Bainbridge, City of, Georgia
- 332. Baldwin, County of, Georgia/  
Baldwin, (Sheriff of) County of, Georgia
- 333. Banks, County of, Georgia
- 334. Bartow, County of, Georgia
- 335. Ben Hill, County of, Georgia
- 336. Bibb, County of, Georgia/  
Bibb, (Sheriff of) County of, Georgia

- 337. Brantley, County of, Georgia
- 338. Bulloch, County of, Georgia
- 339. Burke, County of, Georgia
- 340. Butts, County of, Georgia
- 341. Camden, County of, Georgia
- 342. Candler, County of, Georgia
- 343. Carroll, County of, Georgia
- 344. Catoosa, County of, Georgia
- 345. Charlton, County of, Georgia
- 346. Cherokee, County of, Georgia
- 347. Clay, County of, Georgia
- 348. Clayton, County of, Georgia
- 349. Clinch, County of, Georgia
- 350. Cobb, County of, Georgia
- 351. Coffee, County of, Georgia/ Coffee,  
(Sheriff of) County of, Georgia
- 352. Columbia, County of, Georgia
- 353. Columbus, City of, Georgia
- 354. Cook, County of, Georgia
- 355. Crisp, County of, Georgia/ Crisp,  
(Sheriff of) County of, Georgia
- 356. Dade, County of, Georgia
- 357. Dawson, County of, Georgia
- 358. Decatur, County of, Georgia
- 359. DeKalb, County of, Georgia
- 360. Dooly, County of, Georgia
- 361. Dougherty, County of, Georgia
- 362. Early, County of, Georgia
- 363. Effingham, County of, Georgia
- 364. Elbert, County of, Georgia
- 365. Emanuel, County of, Georgia
- 366. Evans, County of, Georgia
- 367. Fayette, County of, Georgia
- 368. Fitzgerald, City of, Georgia
- 369. Forsyth, County of, Georgia
- 370. Fulton, County of, Georgia
- 371. Gainesville, City of, Georgia
- 372. Glascock, County of, Georgia
- 373. Glynn, County of, Georgia/ Glynn,  
(Sheriff of) County of, Georgia
- 374. Grady, County of, Georgia
- 375. Greene, County of, Georgia
- 376. Gwinnett, County of, Georgia
- 377. Habersham, County of, Georgia
- 378. Hall, County of, Georgia
- 379. Hancock, County of, Georgia
- 380. Henry, County of, Georgia
- 381. Houston, County of, Georgia/  
Houston, (Sheriff of) County of,  
Georgia
- 382. Irwin, County of, Georgia
- 383. Jackson, County of, Georgia
- 384. Jasper, County of, Georgia
- 385. Jeff Davis, County of, Georgia/ Jeff  
Davis, (Sheriff of) County of,  
Georgia
- 386. Jefferson, County of, Georgia
- 387. Johnson, County of, Georgia
- 388. Jones, County of, Georgia
- 389. Laurens, County of, Georgia
- 390. Lee, County of, Georgia
- 391. Liberty, County of, Georgia
- 392. Lincoln, County of, Georgia
- 393. Long, County of, Georgia
- 394. Lowndes, County of, Georgia
- 395. Lumpkin, County of, Georgia
- 396. Macon-Bibb County, Consolidated  
Government of, Georgia
- 397. Madison, County of, Georgia
- 398. McDuffie, County of, Georgia
- 399. McIntosh, County of, Georgia
- 400. Milledgeville, City of, Georgia
- 401. Monroe, County of, Georgia
- 402. Montgomery, County of, Georgia
- 403. Newton, County of, Georgia
- 404. Oconee, County of, Georgia
- 405. Oglethorpe, County of, Georgia
- 406. Pike, County of, Georgia
- 407. Polk, County of, Georgia
- 408. Pulaski, County of, Georgia
- 409. Rabun, County of, Georgia
- 410. Randolph, County of, Georgia
- 411. Rockdale, County of, Georgia
- 412. Rome, City of, Georgia
- 413. Savannah, City of, Georgia
- 414. Screven, County of, Georgia
- 415. Seminole, County of, Georgia
- 416. Spalding, County of, Georgia
- 417. Springfield, City of, Georgia
- 418. Stephens, County of, Georgia
- 419. Sumter, County of, Georgia
- 420. Taliaferro, County of, Georgia

421. Tattnall, County of, Georgia  
422. Tift, County of, Georgia/ Tift,  
(Sheriff of) County of, Georgia  
423. Tifton, City of, Georgia  
424. Toombs, County of, Georgia  
425. Towns, County of, Georgia  
426. Troup, County of, Georgia  
427. Twiggs, County of, Georgia  
428. Union, County of, Georgia  
429. Walton, County of, Georgia  
430. Ware, County of, Georgia/ Ware,  
(Sheriff of) County of, Georgia  
431. Warren, County of, Georgia  
432. Washington, County of, Georgia  
433. Wayne, County of, Georgia/ Wayne,  
(Sheriff of) County of, Georgia  
434. Wilkes, County of, Georgia  
435. Worth, County of, Georgia  
436. Kaua'i, County of, Hawaii  
437. Ada, County of, Idaho  
438. Adams, County of, Idaho  
439. Bingham, County of, Idaho  
440. Blaine, County of, Idaho  
441. Boise, County of, Idaho  
442. Bonneville, County of, Idaho  
443. Camas, County of, Idaho  
444. Canyon, County of, Idaho  
445. Caribou, County of, Idaho  
446. Cassia, County of, Idaho  
447. Elmore, County of, Idaho  
448. Gooding, County of, Idaho  
449. Latah, County of, Idaho  
450. Minidoka, County of, Idaho  
451. Owyhee, County of, Idaho  
452. Payette, County of, Idaho  
453. Board of Education of East Aurora,  
School District 131, Illinois  
454. Board of Education of Joliet  
Township High School, District 204,  
Illinois  
455. Board of Education of Thornton  
Fractional Township High Schools,  
District 215, Illinois  
456. Board of Education of Thornton  
Township High Schools, District  
205, Illinois  
457. Boone, County of, Illinois  
458. Bureau, County of, Illinois  
459. Calhoun, County of, Illinois  
460. Champaign, County of, Illinois  
461. Chicago, City of, Illinois  
462. Chicago School District No. 299,  
Illinois  
463. Christian, County of, Illinois  
464. Coles, County of, Illinois  
465. Cook, County of, Illinois  
466. Dekalb, County of, Illinois  
467. DuPage, County of, Illinois  
468. Effingham, County of, Illinois  
469. Franklin, County of, Illinois  
470. Harrisburg, City of, Illinois  
471. Henry, County of, Illinois  
472. Herrin, City of, Illinois  
473. Jefferson, County of, Illinois  
474. Jersey, County of, Illinois  
475. Johnson, County of, Illinois  
476. Kane, County of, Illinois  
477. Kankakee, County of, Illinois  
478. Kendall, County of, Illinois  
479. Lawrence, County of, Illinois  
480. Lee, County of, Illinois  
481. Livingston, County of, Illinois  
482. Logan, County of, Illinois  
483. Macon, County of, Illinois  
484. Macoupin, County of, Illinois  
485. Marion, City of, Illinois  
486. Marion, County of, Illinois  
487. McHenry, County of, Illinois  
488. Piatt, County of, Illinois  
489. Princeton, City of, Illinois  
490. Putnam, County of, Illinois  
491. Rock Island, County of, Illinois  
492. Rockford, City of, Illinois  
493. Saline, County of, Illinois  
494. Sangamon, County of, Illinois  
495. Schuyler, County of, Illinois  
496. Shelby, County of, Illinois  
497. Stephenson, County of, Illinois  
498. Union, County of, Illinois  
499. West Frankfort, City of, Illinois  
500. White, County of, Illinois  
501. Will, County of, Illinois



- 502. Winnebago, County of, Illinois
- 503. Alexandria, City of, Indiana
- 504. Allen, County of, Indiana
- 505. Atlanta, Town of, Indiana
- 506. Beech Grove, City of, Indiana
- 507. Benton, County of, Indiana
- 508. Bloomington, City of, Indiana
- 509. Brownstown, Town of, Indiana
- 510. Chandler, Town of, Indiana
- 511. Connersville, City of, Indiana
- 512. Danville, Town of, Indiana
- 513. Delaware, County of, Indiana
- 514. Elwood, City of, Indiana
- 515. Evansville, City of, Indiana
- 516. Fishers, City of, Indiana
- 517. Fort Wayne, City of, Indiana
- 518. Franklin, City of, Indiana
- 519. Franklin, County of, Indiana
- 520. Gary, City of, Indiana
- 521. Greenwood, City of, Indiana
- 522. Hammond, City of, Indiana
- 523. Harrison, County of, Indiana
- 524. Howard, County of, Indiana
- 525. Huntington, City of, Indiana
- 526. Indianapolis-Marion County,  
Consolidated Government of,  
Indiana
- 527. Jackson, County of, Indiana
- 528. Jasper, City of, Indiana
- 529. Jeffersonville, City of, Indiana
- 530. Jennings, County of, Indiana
- 531. Lafayette, City of, Indiana
- 532. Lake, County of, Indiana
- 533. LaPorte, County of, Indiana
- 534. Lawrence, City of, Indiana
- 535. Lawrence, County of, Indiana
- 536. Logansport, City of, Indiana
- 537. Madison, City of, Indiana
- 538. Madison, County of, Indiana
- 539. Marshall, County of, Indiana
- 540. Martinsville, City of, Indiana
- 541. Mooresville, Town of, Indiana
- 542. Morgan, County of, Indiana
- 543. Muncie, City of, Indiana
- 544. New Albany, City of, Indiana
- 545. New Castle, City of, Indiana
- 546. Noblesville, City of, Indiana
- 547. Plainfield, Town of, Indiana
- 548. Porter, County of, Indiana
- 549. Portland, City of, Indiana
- 550. Pulaski, County of, Indiana
- 551. Ripley, County of, Indiana
- 552. Scott, County of, Indiana
- 553. Seymour, City of, Indiana
- 554. Sheridan, Town of, Indiana
- 555. South Bend, City of, Indiana
- 556. St. Joseph, County of, Indiana
- 557. Terre Haute, City of, Indiana
- 558. Tippecanoe, County of, Indiana
- 559. Upland, Town of, Indiana
- 560. Vanderburgh, County of, Indiana
- 561. Vigo, County of, Indiana
- 562. West Lafayette, City of, Indiana
- 563. Westfield, City of, Indiana
- 564. Zionsville, Town of, Indiana
- 565. Adair, County of, Iowa
- 566. Adams, County of, Iowa
- 567. Allamakee, County of, Iowa
- 568. Appanoose, County of, Iowa
- 569. Audubon, County of, Iowa
- 570. Benton, County of, Iowa
- 571. Black Hawk, County of, Iowa
- 572. Bremer, County of, Iowa
- 573. Buchanan, County of, Iowa
- 574. Buena Vista, County of, Iowa
- 575. Calhoun, County of, Iowa
- 576. Carroll, County of, Iowa
- 577. Cedar, County of, Iowa
- 578. Cerro Gordo, County of, Iowa
- 579. Cherokee, County of, Iowa
- 580. Chickasaw, County of, Iowa
- 581. Clay, County of, Iowa
- 582. Clayton, County of, Iowa
- 583. Clinton, County of, Iowa
- 584. Dallas, County of, Iowa
- 585. Delaware, County of, Iowa
- 586. Des Moines, County of, Iowa
- 587. Emmet, County of, Iowa
- 588. Fayette, County of, Iowa
- 589. Fremont, County of, Iowa
- 590. Hamilton, County of, Iowa
- 591. Hancock, County of, Iowa

592. Hardin, County of, Iowa  
593. Harrison, County of, Iowa  
594. Henry, County of, Iowa  
595. Howard, County of, Iowa  
596. Humboldt, County of, Iowa  
597. Ida, County of, Iowa  
598. Jasper, County of, Iowa  
599. Johnson, County of, Iowa  
600. Jones, County of, Iowa  
601. Keokuk, County of, Iowa  
602. Lee, County of, Iowa  
603. Lyon, County of, Iowa  
604. Madison, County of, Iowa  
605. Mahaska, County of, Iowa  
606. Marion, County of, Iowa  
607. Mills, County of, Iowa  
608. Mitchell, County of, Iowa  
609. Monroe, County of, Iowa  
610. Montgomery, County of, Iowa  
611. Muscatine, County of, Iowa  
612. O'Brien, County of, Iowa  
613. Osceola, County of, Iowa  
614. Plymouth, County of, Iowa  
615. Pocahontas, County of, Iowa  
616. Polk, County of, Iowa  
617. Pottawattamie, County of, Iowa  
618. Poweshiek, County of, Iowa  
619. Sac, County of, Iowa  
620. Scott, County of, Iowa  
621. Shelby, County of, Iowa  
622. Sioux, County of, Iowa  
623. Tama, County of, Iowa  
624. Taylor, County of, Iowa  
625. Union, County of, Iowa  
626. Webster, County of, Iowa  
627. Winnebago, County of, Iowa  
628. Winneshiek, County of, Iowa  
629. Worth, County of, Iowa  
630. Wright, County of, Iowa  
631. Allen, County of, Kansas/ Allen,  
(District Attorney of) County of,  
Kansas  
632. Barber, County of, Kansas  
633. Bourbon, County of, Kansas  
634. Cherokee, County of, Kansas  
635. Cowley, County of, Kansas  
636. Crawford, County of, Kansas  
637. Dickinson, County of, Kansas/  
Dickinson, (District Attorney of)  
County of, Kansas  
638. Elk, County of, Kansas/ Elk,  
(District Attorney of) County of,  
Kansas  
639. Elkhardt, City of, Kansas  
640. Finney, County of, Kansas/ Finney,  
(Board of County Commissioners of)  
County of, Kansas  
641. Ford, (Board of County  
Commissioners of) County of,  
Kansas  
642. Greenwood, County of, Kansas/  
Greenwood, (District Attorney of)  
County of, Kansas  
643. Harvey, County of, Kansas  
644. Johnson, County of, Kansas  
645. Kansas, City of, Kansas  
646. Leavenworth, County of, Kansas  
647. Manter, City of, Kansas  
648. Meade, County of, Kansas/ Meade,  
(District Attorney of) County of,  
Kansas  
649. Montgomery, County of, Kansas  
650. Morton, County of, Kansas/ Morton,  
(District Attorney of) County of,  
Kansas  
651. Neosho, County of, Kansas  
652. Overland Park, City of, Kansas  
653. Pratt, County of, Kansas  
654. Reno, County of, Kansas  
655. Sedgwick, County of, Kansas  
656. Seward, County of, Kansas/ Seward,  
(District Attorney of) County of,  
Kansas  
657. Stanton, County of, Kansas/ Stanton,  
(District Attorney of) County of,  
Kansas  
658. Ulysses, City of, Kansas  
659. Wabaunsee, County of, Kansas/  
Wabaunsee, (District Attorney of)  
County of, Kansas  
660. Wichita, City of, Kansas/ Wichita,  
(District Attorney of) City of, Kansas

- 661. Wyandotte, County of, Kansas
- 662. Adair, County of, Kentucky
- 663. Anderson, County of, Kentucky
- 664. Bell, County of, Kentucky
- 665. Bellefonte, City of, Kentucky
- 666. Benham, City of, Kentucky
- 667. Board of Education of Breathitt County Public Schools, Kentucky
- 668. Board of Education of Bullitt County Public Schools, Kentucky
- 669. Board of Education of Estill County Public Schools, Kentucky
- 670. Board of Education of Fayette County Public Schools, Kentucky
- 671. Board of Education of Hart County Public Schools, Kentucky
- 672. Board of Education of Jefferson County Public Schools, Kentucky
- 673. Board of Education of Johnson County Public School District, Kentucky
- 674. Board of Education of LaRue County Public Schools, Kentucky
- 675. Board of Education of Lawrence County Public Schools, Kentucky
- 676. Board of Education of Martin County Public Schools, Kentucky
- 677. Board of Education of Menifee County Public Schools, Kentucky
- 678. Board of Education of Owsley County Public Schools, Kentucky
- 679. Board of Education of Wolfe County Public Schools, Kentucky
- 680. Boone, County of, Kentucky
- 681. Bourbon, County of, Kentucky
- 682. Boyd, County of, Kentucky
- 683. Boyle, County of, Kentucky
- 684. Breckinridge, County of, Kentucky
- 685. Buckhorn, City of, Kentucky
- 686. Campbell, County of, Kentucky
- 687. Christian, County of, Kentucky
- 688. Clark, County of, Kentucky
- 689. Covington, City of, Kentucky
- 690. Edmonson, County of, Kentucky
- 691. Estill, County of, Kentucky
- 692. Floyd, County of, Kentucky
- 693. Franklin, County of, Kentucky
- 694. Grant, County of, Kentucky
- 695. Green, County of, Kentucky
- 696. Greenup, City of, Kentucky
- 697. Hardin, County of, Kentucky
- 698. Harlan, City of, Kentucky
- 699. Harlan, County of, Kentucky
- 700. Henderson, County of, Kentucky
- 701. Hopkins, County of, Kentucky
- 702. Hyden, City of, Kentucky
- 703. Jenkins, City of, Kentucky
- 704. Jessamine, County of, Kentucky
- 705. Kenton, County of, Kentucky
- 706. Knott, County of, Kentucky
- 707. Knox, County of, Kentucky
- 708. Lawrence, County of, Kentucky
- 709. Letcher, County of, Kentucky
- 710. Lexington-Fayette, Urban County of, Kentucky
- 711. Lincoln, County of, Kentucky
- 712. London, City of, Kentucky
- 713. Louisville/Jefferson, County Metro Government of, Kentucky
- 714. Loyall, City of, Kentucky
- 715. Lynch, City of, Kentucky
- 716. Madison, County of, Kentucky
- 717. Manchester, City of, Kentucky
- 718. Marshall, County of, Kentucky
- 719. McCracken, County of, Kentucky
- 720. Meade, County of, Kentucky
- 721. Monroe, County of, Kentucky
- 722. Montgomery, County of, Kentucky
- 723. Morehead, City of, Kentucky
- 724. Ohio, County of, Kentucky
- 725. Oldham, County of, Kentucky
- 726. Owsley, County of, Kentucky
- 727. Paducah, City of, Kentucky
- 728. Perry, County of, Kentucky
- 729. Pike, County of, Kentucky
- 730. Pineville, City of, Kentucky
- 731. Pippa Passes, City of, Kentucky
- 732. Prestonsburg, City of, Kentucky
- 733. Pulaski, County of, Kentucky
- 734. Rowan, County of, Kentucky
- 735. Russell, City of, Kentucky
- 736. Scott, County of, Kentucky

737. Shelby, County of, Kentucky  
738. South Shore, City of, Kentucky  
739. Union, County of, Kentucky  
740. Vanceburg, City of, Kentucky  
741. Warren, County of, Kentucky  
742. Wayne, County of, Kentucky  
743. Whitesburg, City of, Kentucky  
744. Whitley, County of, Kentucky  
745. Worthington, City of, Kentucky  
746. Alexandria, City of, Louisiana  
747. Allen, Parish of, Louisiana/ Allen, (Sheriff of) Parish of, Louisiana  
748. Ascension, Parish of, Louisiana / Ascension, (Sheriff of) Parish of, Louisiana  
749. Ascension Parish School Board, Louisiana  
750. Assumption, Parish of, Louisiana/ Assumption, (Police Jury of) Parish of, Louisiana/ Assumption, (Sheriff of) Parish of, Louisiana  
751. Avoyelles, Parish of, Louisiana/ Avoyelles, (Police Jury of) Parish of, Louisiana/ Avoyelles, (Sheriff of) Parish of, Louisiana  
752. Baldwin, Town of, Louisiana  
753. Bastrop, City of, Louisiana  
754. Baton Rouge, City of, Louisiana  
755. Beauregard, Parish of, Louisiana  
756. Benton Fire Protection District No. 4, Louisiana  
757. Berwick, Town of, Louisiana  
758. Bogalusa, City of, Louisiana  
759. Bossier, City of, Louisiana  
760. Bossier, Parish of, Louisiana  
761. Caddo Fire Protection District No. 1, Louisiana  
762. Caddo, Parish of, Louisiana  
763. Calcasieu, Parish of, Louisiana/ Calcasieu, (Police Jury of) Parish of, Louisiana/ Calcasieu, (Sheriff of) Parish of, Louisiana  
764. Caldwell, Parish of, Louisiana  
765. Catahoula, Parish of, Louisiana/ Catahoula, (Sheriff of) Parish of, Louisiana  
766. Claiborne, Parish of, Louisiana  
767. Concordia, Parish of, Louisiana/ Concordia, (Sheriff of) Parish of, Louisiana  
768. Delhi, Town of, Louisiana  
769. Desoto Fire Protection District No. 8, Louisiana  
770. Donaldsonville, City of, Louisiana  
771. East Baton Rouge, Parish of, Louisiana/ East Baton Rouge, (Sheriff of) Parish of, Louisiana  
772. East Carroll, Parish of, Louisiana/ East Carroll, (Sheriff of) Parish of, Louisiana  
773. Eunice, City of, Louisiana  
774. Evangeline, Parish of, Louisiana/ Evangeline, (Police Jury of) Parish of, Louisiana/ Evangeline, (Sheriff of) Parish of, Louisiana  
775. Ferriday, Town of, Louisiana  
776. Franklin, City of, Louisiana  
777. Franklin, Parish of, Louisiana  
778. Gramercy, Town of, Louisiana  
779. Grant, Parish of, Louisiana/ Grant, (District Attorney of) Parish of, Louisiana  
780. Iberia, Parish of, Louisiana/ Iberia, (Sheriff of) Parish of, Louisiana  
781. Iberia Parish School Board, Louisiana  
782. Jackson, Parish of, Louisiana  
783. Jefferson Davis, Parish of, Louisiana/ Jefferson Davis, (Police Jury of) Parish of, Louisiana/ Jefferson Davis, (Sheriff of) Parish of, Louisiana  
784. Jefferson, Parish of, Louisiana/ Jefferson, (Sheriff of) Parish of, Louisiana  
785. Kenner, City of, Louisiana  
786. Lafayette, Parish of, Louisiana/ Lafayette, (Sheriff of) Parish of, Louisiana  
787. Lafourche, Parish of, Louisiana  
788. Lafourche Parish School Board, Louisiana

789. Lake Charles, City of, Louisiana
790. Lake Providence, Town of, Louisiana
791. LaSalle, Parish of, Louisiana
792. Lutcher, Town of, Louisiana
793. Madisonville, Town of, Louisiana
794. Mandeville, City of, Louisiana
795. Monroe, City of, Louisiana
796. Morehouse, Parish of, Louisiana/  
Morehouse, (Sheriff of) Parish of, Louisiana
797. Natchitoches, City of, Louisiana/  
Natchitoches, (District Attorney of) Parish of, Louisiana
798. New Iberia, City of, Louisiana
799. New Orleans, City of, Louisiana/  
New Orleans, (Sheriff of) City of, Louisiana
800. New Roads, City of, Louisiana
801. Opelousas, City of, Louisiana
802. Orleans, Parish of, Louisiana/  
Orleans, (Sheriff of) Parish of, Louisiana
803. Ouachita, Parish of, Louisiana/  
Ouachita, (Police Jury of) Parish of, Louisiana/  
Ouachita, (Sheriff of) Parish of, Louisiana
804. Patterson, City of, Louisiana
805. Pearl River, Town of, Louisiana
806. Pineville, City of, Louisiana
807. Pointe Coupee, Parish of, Louisiana
808. Prevost Memorial Hospital, Louisiana
809. Rapides, Parish of, Louisiana/  
Rapides, (District Attorney of) Parish of, Louisiana/  
Rapides, (Sheriff of) Parish of, Louisiana
810. Red River Fire Protection District, Louisiana
811. Red River, Parish of, Louisiana
812. Richland, Parish of, Louisiana/  
Richland, (Sheriff of) Parish of, Louisiana
813. Richwood, Town of, Louisiana
814. Sabine, Parish of, Louisiana/  
Sabine, (Police Jury of) Parish of, Louisiana/  
Sabine, (Sheriff of) Parish of, Louisiana
815. Saint Martinville, City of, Louisiana
816. Shreveport, City of, Louisiana
817. Slidell, City of, Louisiana
818. St. Bernard, Parish of, Louisiana/  
St. Bernard, (Sheriff of) Parish of, Louisiana
819. St. Bernard Parish School Board, Louisiana
820. St. Charles, Parish of, Louisiana/  
St. Charles, (Sheriff of) Parish of, Louisiana
821. St. James, Parish of, Louisiana
822. St. James Parish School Board, Louisiana
823. St. John the Baptist, Parish of, Louisiana
824. St. Landry, Parish of, Louisiana/  
St. Landry, (President of) Parish of, Louisiana/  
St. Landry, (Sheriff of) Parish of, Louisiana
825. St. Martin, Parish of, Louisiana
826. St. Mary, Parish of, Louisiana/  
St. Mary, (District Attorney of) Parish of, Louisiana/  
St. Mary, (Sheriff of) Parish of, Louisiana
827. St. Mary Parish School Board, Louisiana
828. St. Tammany Fire Protection District No. 1, Louisiana
829. St. Tammany Fire Protection District No. 2, Louisiana
830. St. Tammany Fire Protection District No. 3, Louisiana
831. St. Tammany Fire Protection District No. 4, Louisiana
832. St. Tammany Fire Protection District No. 5, Louisiana
833. St. Tammany Fire Protection District No. 12, Louisiana
834. St. Tammany Fire Protection District No. 13, Louisiana
835. St. Tammany, Parish of, Louisiana/  
St. Tammany, (Coroner's Office of)

- Parish of, Louisiana/ St. Tammany,  
(Sheriff of) Parish of, Louisiana
836. Tensas, Parish of, Louisiana/ Tensas,  
(Sheriff of) Parish of, Louisiana
837. Union, Parish of, Louisiana
838. Vermillion, (Police Jury of) Parish  
of, Louisiana
839. Vernon, Parish of, Louisiana/  
Vernon, (Sheriff of) Parish of,  
Louisiana
840. Washington, Parish of, Louisiana/  
Washington, (Sheriff of) Parish of,  
Louisiana
841. Webster, Parish of, Louisiana
842. West Ascension Parish Hospital  
Service District, Louisiana
843. West Baton Rouge Fire Protection  
District No. 1, Louisiana
844. West Baton Rouge, Parish of,  
Louisiana
845. West Carroll, Parish of, Louisiana/  
West Carroll, (Sheriff of) Parish of,  
Louisiana
846. West Monroe, Parish of, Louisiana
847. Winn, Parish of, Louisiana/ Winn,  
(District Attorney of) Parish of,  
Louisiana
848. Androscoggin, County of, Maine
849. Aroostook, County of, Maine
850. Auburn, City of, Maine
851. Augusta, City of, Maine
852. Bangor, City of, Maine
853. Biddeford, City of, Maine
854. Board of Education of Bangor  
School Department, Maine
855. Board of Education of Cape  
Elizabeth School Department, Maine
856. Board of Education of Ellsworth  
School Department, Maine
857. Board of Education of Maine  
Regional School Unit 10, Maine
858. Board of Education of Maine  
Regional School Unit 13, Maine
859. Board of Education of Maine  
Regional School Unit 25, Maine
860. Board of Education of Maine  
Regional School Unit 26, Maine
861. Board of Education of Maine  
Regional School Unit 29, Maine
862. Board of Education of Maine  
Regional School Unit 34, Maine
863. Board of Education of Maine  
Regional School Unit 40, Maine
864. Board of Education of Maine  
Regional School Unit 50, Maine
865. Board of Education of Maine  
Regional School Unit 57, Maine
866. Board of Education of Maine  
Regional School Unit 60, Maine
867. Board of Education of Maine  
Regional School Unit 71, Maine
868. Board of Education of Maine  
Regional School Unit 9, Maine
869. Board of Education of Maine School  
Administrative District 11, Maine
870. Board of Education of Maine School  
Administrative District 15, Maine
871. Board of Education of Maine School  
Administrative District 28/Five  
Town Central School District, Maine
872. Board of Education of Maine School  
Administrative District 35, Maine
873. Board of Education of Maine School  
Administrative District 44, Maine
874. Board of Education of Maine School  
Administrative District 53, Maine
875. Board of Education of Maine School  
Administrative District 55, Maine
876. Board of Education of Maine School  
Administrative District 6, Maine
877. Board of Education of Maine School  
Administrative District 61, Maine
878. Board of Education of Maine School  
Administrative District 72, Maine
879. Board of Education of Portland  
School Department, Maine
880. Board of Education of Scarborough  
School Department, Maine
881. Board of Education of South  
Portland School Department, Maine

882. Board of Education of St. George  
Municipal School District, Maine
883. Board of Education of Waterville  
School Department, Maine
884. Calais, City of, Maine
885. Cumberland, County of, Maine
886. Kennebec, County of, Maine
887. Knox, County of, Maine
888. Lewiston, City of, Maine
889. Lincoln, County of, Maine
890. Penobscot, County of, Maine
891. Portland, City of, Maine
892. Rockland, City of, Maine
893. Saco, City of, Maine
894. Sagadahoc, County of, Maine
895. Sanford, City of, Maine
896. Somerset, County of, Maine
897. Waldo, County of, Maine
898. Washington, County of, Maine
899. Waterville, City of, Maine
900. York, County of, Maine
901. Aberdeen, City of, Maryland
902. Allegany, County of, Maryland
903. Baltimore City Board of School  
Commissioners, Maryland
904. Bel Air, Town of, Maryland
905. Berlin, Town of, Maryland
906. Bowie, City of, Maryland
907. Calvert, County of, Maryland
908. Cambridge, City of, Maryland
909. Caroline, County of, Maryland
910. Cecil, County of, Maryland
911. Charles, County of, Maryland
912. Charlestown, Town of, Maryland
913. Cumberland, City of, Maryland
914. Dorchester, County of, Maryland
915. Frederick, City of, Maryland
916. Frederick, County of, Maryland
917. Frostburg, City of, Maryland
918. Garrett, County of, Maryland
919. Grantsville, Town of, Maryland
920. Hagerstown, City of, Maryland
921. Harford, County of, Maryland
922. Havre De Grace, City of, Maryland
923. Laurel, City of, Maryland
924. Mountain Lake Park, Town of,  
Maryland
925. North East, Town of, Maryland
926. Oakland, Town of, Maryland
927. Perryville, Town of, Maryland
928. Prince George's, County of,  
Maryland
929. Rockville, City of, Maryland
930. Seat Pleasant, City of, Maryland
931. Somerset, County of, Maryland
932. St. Mary's, County of, Maryland
933. Talbot, County of, Maryland
934. Vienna, Town of, Maryland
935. Washington, County of, Maryland
936. Westminster, City of, Maryland
937. Wicomico, County of, Maryland
938. Acushnet, Town of, Massachusetts
939. Agawam, City of, Massachusetts
940. Amesbury, City of, Massachusetts
941. Aquinnah, Town of, Massachusetts
942. Athol, Town of, Massachusetts
943. Auburn, Town of, Massachusetts
944. Ayer, Town of, Massachusetts
945. Barnstable, Town of, Massachusetts
946. Belchertown, Town of,  
Massachusetts
947. Beverly, City of, Massachusetts
948. Billerica, Town of, Massachusetts
949. Brewster, Town of, Massachusetts
950. Bridgewater, Town of,  
Massachusetts
951. Brockton, City of, Massachusetts
952. Brookline, Town of, Massachusetts
953. Cambridge, City of, Massachusetts
954. Canton, Town of, Massachusetts
955. Carver, Town of, Massachusetts
956. Charlton, Town of, Massachusetts
957. Chelmsford, Town of, Massachusetts
958. Chicopee, City of, Massachusetts
959. Clarksburg, Town of, Massachusetts
960. Clinton, Town of, Massachusetts
961. Danvers, Town of, Massachusetts
962. Dedham, Town of, Massachusetts
963. Dennis, Town of, Massachusetts
964. Douglas, Town of, Massachusetts
965. Dudley, Town of, Massachusetts

- 966. East Bridgewater, Town of, Massachusetts
- 967. Eastham, Town of, Massachusetts
- 968. Easthampton, City of, Massachusetts
- 969. Easton, Town of, Massachusetts
- 970. Everett, City of, Massachusetts
- 971. Fairhaven, Town of, Massachusetts
- 972. Falmouth, Town of, Massachusetts
- 973. Fitchburg, City of, Massachusetts
- 974. Framingham, City of, Massachusetts
- 975. Freetown, Town of, Massachusetts
- 976. Georgetown, Town of, Massachusetts
- 977. Gloucester, City of, Massachusetts
- 978. Grafton, Town of, Massachusetts
- 979. Greenfield, City of, Massachusetts
- 980. Hanson, Town of, Massachusetts
- 981. Haverhill, City of, Massachusetts
- 982. Holliston, Town of, Massachusetts
- 983. Holyoke, City of, Massachusetts
- 984. Hopedale, Town of, Massachusetts
- 985. Hull, Town of, Massachusetts
- 986. Kingston, Town of, Massachusetts
- 987. Lakeville, Town of, Massachusetts
- 988. Leicester, Town of, Massachusetts
- 989. Leominster, City of, Massachusetts
- 990. Leverett, Town of, Massachusetts
- 991. Longmeadow, Town of, Massachusetts
- 992. Lowell, City of, Massachusetts
- 993. Ludlow, Town of, Massachusetts
- 994. Lunenburg, Town of, Massachusetts
- 995. Lynn, City of, Massachusetts
- 996. Lynnfield, Town of, Massachusetts
- 997. Malden, City of, Massachusetts
- 998. Marblehead, Town of, Massachusetts
- 999. Marshfield, Town of, Massachusetts
- 1000. Mashpee, Town of, Massachusetts
- 1001. Mattapoisett, Town of, Massachusetts
- 1002. Medford, City of, Massachusetts
- 1003. Melrose, City of, Massachusetts
- 1004. Methuen, City of, Massachusetts
- 1005. Middleborough, Town of, Massachusetts
- 1006. Milford, Town of, Massachusetts
- 1007. Millbury, Town of, Massachusetts
- 1008. Millis, Town of, Massachusetts
- 1009. Natick, Town of, Massachusetts
- 1010. New Bedford, Town of, Massachusetts
- 1011. Newburyport, City of, Massachusetts
- 1012. North Adams, City of, Massachusetts
- 1013. North Andover, Town of, Massachusetts
- 1014. North Attleborough, Town of, Massachusetts
- 1015. North Reading, Town of, Massachusetts
- 1016. Northampton, City of, Massachusetts
- 1017. Northbridge, Town of, Massachusetts
- 1018. Norton, Town of, Massachusetts
- 1019. Norwell, Town of, Massachusetts
- 1020. Norwood, Town of, Massachusetts
- 1021. Orange, Town of, Massachusetts
- 1022. Oxford, Town of, Massachusetts
- 1023. Palmer, City of, Massachusetts
- 1024. Peabody, City of, Massachusetts
- 1025. Pembroke, Town of, Massachusetts
- 1026. Pittsfield, City of, Massachusetts
- 1027. Plainville, Town of, Massachusetts
- 1028. Plymouth, Town of, Massachusetts
- 1029. Provincetown, Town of, Massachusetts
- 1030. Randolph, City of, Massachusetts
- 1031. Rehoboth, Town of, Massachusetts
- 1032. Rockland, Town of, Massachusetts
- 1033. Salem, City of, Massachusetts
- 1034. Salisbury, Town of, Massachusetts
- 1035. Sandwich, Town of, Massachusetts
- 1036. Scituate, Town of, Massachusetts
- 1037. Seekonk, Town of, Massachusetts
- 1038. Sheffield, Town of, Massachusetts
- 1039. Shirley, Town of, Massachusetts
- 1040. Somerset, Town of, Massachusetts
- 1041. South Hadley, Town of, Massachusetts
- 1042. Southbridge, City of, Massachusetts
- 1043. Spence, Town of, Massachusetts
- 1044. Springfield, City of, Massachusetts
- 1045. Stoneham, Town of, Massachusetts



- 1046. Stoughton, Town of, Massachusetts
- 1047. Sturbridge, Town of, Massachusetts
- 1048. Sudbury, Town of, Massachusetts
- 1049. Sutton, Town of, Massachusetts
- 1050. Swampscott, Town of,  
Massachusetts
- 1051. Templeton, Town of, Massachusetts
- 1052. Tewksbury, Town of, Massachusetts
- 1053. Truro, Town of, Massachusetts
- 1054. Tyngsborough, Town of,  
Massachusetts
- 1055. Upton, Town of, Massachusetts
- 1056. Wakefield, Town of, Massachusetts
- 1057. Walpole, Town of, Massachusetts
- 1058. Ware, Town of, Massachusetts
- 1059. Warren, Town of, Massachusetts
- 1060. Watertown, City of, Massachusetts
- 1061. Wellfleet, Town of, Massachusetts
- 1062. West Boylston, Town of,  
Massachusetts
- 1063. West Bridgewater, Town of,  
Massachusetts
- 1064. West Springfield, City of,  
Massachusetts
- 1065. Westborough, Town of,  
Massachusetts
- 1066. Westford, Town of, Massachusetts
- 1067. Williamsburg, Town of,  
Massachusetts
- 1068. Wilmington, Town of,  
Massachusetts
- 1069. Winchendon, Town of,  
Massachusetts
- 1070. Woburn, City of, Massachusetts
- 1071. Worcester, City of, Massachusetts
- 1072. Alcona, County of, Michigan
- 1073. Alger, County of, Michigan
- 1074. Alpena, County of, Michigan
- 1075. Antrim, County of, Michigan
- 1076. Arenac, County of, Michigan
- 1077. Baraga, County of, Michigan
- 1078. Benzie, County of, Michigan
- 1079. Berrien, County of, Michigan
- 1080. Branch, County of, Michigan
- 1081. Calhoun, County of, Michigan
- 1082. Canton, Charter Township of,  
Michigan
- 1083. Cass, County of, Michigan
- 1084. Charlevoix, County of, Michigan
- 1085. Chippewa, County of, Michigan
- 1086. Clinton, County of, Michigan
- 1087. Clinton, Village of, Michigan
- 1088. Crawford, County of, Michigan
- 1089. Delta, County of, Michigan
- 1090. Detroit, City of, Michigan
- 1091. Dickinson, County of, Michigan
- 1092. East Lansing, City of, Michigan
- 1093. Eaton, County of, Michigan
- 1094. Escanaba, City of, Michigan
- 1095. Genesee, County of, Michigan
- 1096. Grand Rapids, City of, Michigan
- 1097. Grand Traverse, County of,  
Michigan
- 1098. Gratiot, County of, Michigan
- 1099. Hillsdale, County of, Michigan
- 1100. Houghton, County of, Michigan
- 1101. Huron Charter Township, Township  
of, Michigan
- 1102. Ingham, County of, Michigan
- 1103. Ionia, County of, Michigan
- 1104. Iosco, County of, Michigan
- 1105. Iron, County of, Michigan
- 1106. Iron Mountain, City of, Michigan
- 1107. Isabella, County of, Michigan
- 1108. Jackson, City of, Michigan
- 1109. Kalamazoo, County of, Michigan
- 1110. Kent, County of, Michigan
- 1111. Lake, County of, Michigan
- 1112. Lansing, City of, Michigan
- 1113. Leelanau, County of, Michigan
- 1114. Lenawee, County of, Michigan
- 1115. Livingston, County of, Michigan
- 1116. Livonia, City of, Michigan
- 1117. Luce, County of, Michigan
- 1118. Macomb, County of, Michigan
- 1119. Manistee, County of, Michigan
- 1120. Marquette, County of, Michigan
- 1121. Mason, County of, Michigan
- 1122. Monroe, County of, Michigan
- 1123. Montcalm, County of, Michigan
- 1124. Montmorency, County of, Michigan

- 1125. Muskegon, County of, Michigan
- 1126. Newaygo, County of, Michigan
- 1127. Northville, City of, Michigan
- 1128. Oceana, County of, Michigan
- 1129. Ogemaw, County of, Michigan
- 1130. Ontongon, County of, Michigan
- 1131. Osceola, County of, Michigan
- 1132. Otsego, County of, Michigan
- 1133. Pittsfield Charter Township,  
Township of, Michigan
- 1134. Pontiac, City of, Michigan
- 1135. Presque Isle, County of, Michigan
- 1136. Romulus, City of, Michigan
- 1137. Roscommon, County of, Michigan
- 1138. Saginaw, County of, Michigan
- 1139. Sanilac, County of, Michigan
- 1140. Sault Ste. Marie, City of, Michigan
- 1141. Shiawassee, County of, Michigan
- 1142. St. Clair, County of, Michigan
- 1143. Traverse, City of, Michigan
- 1144. Tuscola, County of, Michigan
- 1145. Van Buren Charter Township,  
Township of, Michigan
- 1146. Washtenaw, County of, Michigan
- 1147. Wayne, City of, Michigan
- 1148. Westland, City of, Michigan
- 1149. Wexford, County of, Michigan
- 1150. Anoka, County of, Minnesota
- 1151. Big Stone, County of, Minnesota
- 1152. Board of Education of Minnetonka  
School District No. 276, Minnesota
- 1153. Dakota, County of, Minnesota
- 1154. Douglas, County of, Minnesota
- 1155. Itasca, County of, Minnesota
- 1156. McLeod, County of, Minnesota
- 1157. Meeker, County of, Minnesota
- 1158. Morrison, County of, Minnesota
- 1159. Mower, County of, Minnesota
- 1160. St. Louis, County of, Minnesota
- 1161. St. Paul, City of, Minnesota
- 1162. Washington, County of, Minnesota
- 1163. Winona, County of, Minnesota
- 1164. Adams, County of, Mississippi
- 1165. Amite, County of, Mississippi
- 1166. Amory, City of, Mississippi
- 1167. Arcola, Town of, Mississippi
- 1168. Bolivar, County of, Mississippi
- 1169. Brookhaven, City of, Mississippi
- 1170. Centreville, Town of, Mississippi
- 1171. Clarksdale, City of, Mississippi
- 1172. Columbia, City of, Mississippi
- 1173. Covington, County of, Mississippi
- 1174. DeSoto, County of, Mississippi
- 1175. Forrest, County of, Mississippi
- 1176. Greenwood, City of, Mississippi
- 1177. Grenada, City of, Mississippi
- 1178. Grenada, County of, Mississippi
- 1179. Gulfport, City of, Mississippi
- 1180. Harrison, County of, Mississippi
- 1181. Hattiesburg, City of, Mississippi
- 1182. Hinds, County of, Mississippi
- 1183. Holly Springs, City of, Mississippi
- 1184. Indianola, City of, Mississippi
- 1185. Issaquena, County of, Mississippi
- 1186. Iuka, City of, Mississippi
- 1187. Jackson, City of, Mississippi
- 1188. Jonestown, Town of, Mississippi
- 1189. Lafayette, County of, Mississippi
- 1190. Laurel, City of, Mississippi
- 1191. Leflore, County of, Mississippi
- 1192. Lincoln, County of, Mississippi
- 1193. Long Beach, City of, Mississippi
- 1194. Lumberton, City of, Mississippi
- 1195. Madison, County of, Mississippi
- 1196. Marion, County of, Mississippi
- 1197. Marshall, County of, Mississippi
- 1198. Meridian, City of, Mississippi
- 1199. Monroe, County of, Mississippi
- 1200. Mound Bayou, City of, Mississippi
- 1201. Neshoba, County of, Mississippi
- 1202. New Albany, City of, Mississippi
- 1203. Pascagoula, City of, Mississippi
- 1204. Pearl River, County of, Mississippi
- 1205. Philadelphia, City of, Mississippi
- 1206. Prentiss, County of, Mississippi
- 1207. Scott, County of, Mississippi
- 1208. Stone, County of, Mississippi
- 1209. Summit, Town of, Mississippi
- 1210. Sunflower, County of, Mississippi
- 1211. Tippah, County of, Mississippi
- 1212. Union, County of, Mississippi
- 1213. Washington, County of, Mississippi

- 1214. Wiggins, City of, Mississippi
- 1215. Audrain, County of, Missouri
- 1216. Barry, County of, Missouri
- 1217. Barton, County of, Missouri
- 1218. Boone, County of, Missouri
- 1219. Buchanan, County of, Missouri
- 1220. Butler, County of, Missouri
- 1221. Callaway, County of, Missouri
- 1222. Camden, County of, Missouri
- 1223. Cape Girardeau, County of, Missouri
- 1224. Cass, County of, Missouri
- 1225. Chariton, County of, Missouri
- 1226. Christian, County of, Missouri
- 1227. Clinton, County of, Missouri
- 1228. Cole, County of, Missouri
- 1229. Crawford, County of, Missouri
- 1230. Dent, County of, Missouri
- 1231. Douglas, County of, Missouri
- 1232. Dunklin, County of, Missouri
- 1233. Franklin, County of, Missouri
- 1234. Gasconade, County of, Missouri
- 1235. Greene, County of, Missouri
- 1236. Harrisonville, Town of, Missouri
- 1237. Henry, County of, Missouri
- 1238. Howell, County of, Missouri
- 1239. Independence, City of, Missouri
- 1240. Iron, County of, Missouri
- 1241. Jackson, County of, Missouri
- 1242. Jasper, County of, Missouri
- 1243. Jefferson, County of, Missouri
- 1244. Johnson, County of, Missouri
- 1245. Joplin, City of, Missouri
- 1246. Kansas, City of, Missouri
- 1247. Knox, County of, Missouri
- 1248. Lafayette, County of, Missouri
- 1249. Lawrence, County of, Missouri
- 1250. Lewis, County of, Missouri
- 1251. Lincoln, County of, Missouri
- 1252. Livingston, County of, Missouri
- 1253. Madison, County of, Missouri
- 1254. Maries, County of, Missouri
- 1255. McDonald, County of, Missouri
- 1256. Miller, County of, Missouri
- 1257. Moniteau, County of, Missouri
- 1258. Montgomery, County of, Missouri
- 1259. Morgan, County of, Missouri
- 1260. Nodaway, County of, Missouri
- 1261. Osage, County of, Missouri
- 1262. Ozark, County of, Missouri
- 1263. Pemiscot, County of, Missouri
- 1264. Perry, County of, Missouri
- 1265. Pettis, County of, Missouri
- 1266. Phelps, County of, Missouri
- 1267. Pike, County of, Missouri
- 1268. Polk, County of, Missouri
- 1269. Pulaski, County of, Missouri
- 1270. Randolph, County of, Missouri
- 1271. Ray, County of, Missouri
- 1272. Reynolds, County of, Missouri
- 1273. Ripley, County of, Missouri
- 1274. Schuyler, County of, Missouri
- 1275. Scott, County of, Missouri
- 1276. Sedalia, City of, Missouri
- 1277. Shannon, County of, Missouri
- 1278. Shelby, County of, Missouri
- 1279. Springfield, City of, Missouri
- 1280. St. Charles, County of, Missouri
- 1281. St. Francois, County of, Missouri
- 1282. St. Joseph, City of, Missouri
- 1283. St. Louis, County of, Missouri
- 1284. Ste. Genevieve, County of, Missouri
- 1285. Stone, County of, Missouri
- 1286. Taney, County of, Missouri
- 1287. Texas, County of, Missouri
- 1288. Vernon, County of, Missouri
- 1289. Warren, County of, Missouri
- 1290. Washington, County of, Missouri
- 1291. Webster, County of, Missouri
- 1292. Wright, County of, Missouri
- 1293. Cascade, County of, Montana
- 1294. Great Falls, City of, Montana
- 1295. Missoula, County of, Montana
- 1296. Douglas, County of, Nebraska
- 1297. Lincoln, County of, Nebraska
- 1298. Sarpy, County of, Nebraska
- 1299. South Sioux, City of, Nebraska
- 1300. Carson, City of, Nevada
- 1301. Churchill, County of, Nevada
- 1302. Clark, County of, Nevada
- 1303. Douglas, County of, Nevada
- 1304. Esmeralda, County of, Nevada
- 1305. Fernley, City of, Nevada

- 1306. Henderson, City of, Nevada
- 1307. Humboldt, County of, Nevada
- 1308. Las Vegas, City of, Nevada
- 1309. North Las Vegas, City of, Nevada
- 1310. Nye, County of, Nevada
- 1311. Sparks, City of, Nevada
- 1312. Washoe, County of, Nevada
- 1313. West Wendover, City of, Nevada
- 1314. Belknap, County of, New Hampshire
- 1315. Belmont, Town of, New Hampshire
- 1316. Berlin, City of, New Hampshire
- 1317. Board of Education of Goshen School District, New Hampshire
- 1318. Board of Education of Kearsarge Regional School Unit-School Administrative Unit 65, New Hampshire
- 1319. Board of Education of Lebanon School District, New Hampshire
- 1320. Board of Education of Pittsfield School District, New Hampshire
- 1321. Board of Education of Tamworth School District, New Hampshire
- 1322. Carroll, County of, New Hampshire
- 1323. Cheshire, County of, New Hampshire
- 1324. Claremont, County of, New Hampshire
- 1325. Concord, City of, New Hampshire
- 1326. Coos, County of, New Hampshire
- 1327. Derry, Town of, New Hampshire
- 1328. Franklin, City of, New Hampshire
- 1329. Grafton, County of, New Hampshire
- 1330. Hillsborough, County of, New Hampshire
- 1331. Keene, City of, New Hampshire
- 1332. Laconia, City of, New Hampshire
- 1333. Londonderry, Town of, New Hampshire
- 1334. Manchester, City of, New Hampshire
- 1335. Nashua, City of, New Hampshire
- 1336. Rochester, City of, New Hampshire
- 1337. Rockingham, County of, New Hampshire
- 1338. Strafford, County of, New Hampshire
- 1339. Sullivan, County of, New Hampshire
- 1340. Barnegat, Township of, New Jersey
- 1341. Bayonne, City of, New Jersey
- 1342. Burlington, County of, New Jersey
- 1343. Clifton, City of, New Jersey
- 1344. Clinton, Town of, New Jersey
- 1345. Elizabeth, City of, New Jersey
- 1346. Hudson, County of, New Jersey
- 1347. Hunterdon, County of, New Jersey
- 1348. Ocean, County of, New Jersey
- 1349. Paramus, Borough of, New Jersey
- 1350. Ridgefield, Borough of, New Jersey
- 1351. Saddlebrook, Township of, New Jersey
- 1352. Trenton, City of, New Jersey
- 1353. Vineland, City of, New Jersey
- 1354. Albany, City of, New York
- 1355. Allegany, County of, New York
- 1356. Amityville, Village of, New York
- 1357. Amsterdam, City of, New York
- 1358. Auburn, City of, New York
- 1359. Babylon, Village of, New York
- 1360. Bellmore Fire District, New York
- 1361. Bellport, Village of, New York
- 1362. Board of Education of Rochester City School District, New York
- 1363. Brookhaven, Town of, New York
- 1364. Broome, County of, New York
- 1365. Buffalo, City of, New York
- 1366. Centereach Fire District, New York
- 1367. Centerport Fire District, New York
- 1368. Clarkstown, Town of, New York
- 1369. Clinton, County of, New York
- 1370. Columbia, County of, New York
- 1371. Cortland, County of, New York
- 1372. Dutchess, County of, New York
- 1373. East Hampton, Village of, New York
- 1374. East Rockaway, Village of, New York
- 1375. Erie, County of, New York
- 1376. Farmingdale, Village of, New York
- 1377. Floral Park, Village of, New York
- 1378. Franklin, County of, New York
- 1379. Friendship Engine & Hose Company, New York
- 1380. Fulton, County of, New York

- 1381. Garden City, Village of, New York
- 1382. Genesee, County of, New York
- 1383. Geneva, City of, New York
- 1384. Great Neck, Village of, New York
- 1385. Greene, County of, New York
- 1386. Greenport, Village of, New York
- 1387. Hamilton, County of, New York
- 1388. Hauppauge Fire District, New York
- 1389. Haverstraw, Town of, New York
- 1390. Hempstead, Town of, New York
- 1391. Hempstead, Village of, New York
- 1392. Herkimer, County of, New York
- 1393. Herkimer, Town of, New York
- 1394. Hicksville Water District, New York
- 1395. Huntington, Town of, New York
- 1396. Island Park, Village of, New York
- 1397. Islandia, Village of, New York
- 1398. Islip Terrace Fire District, New York
- 1399. Islip, Town of, New York
- 1400. Ithaca, City of, New York
- 1401. Jefferson, County of, New York
- 1402. Kingston, City of, New York
- 1403. Lackawanna, City of, New York
- 1404. Lake Grove, Village of, New York
- 1405. Lawrence, Village of, New York
- 1406. Levittown Fire District, New York
- 1407. Lewis, County of, New York
- 1408. Lindenhurst, Village of, New York
- 1409. Lloyd Harbor, Village of, New York
- 1410. Long Beach, City of, New York
- 1411. Lynbrook, Village of, New York
- 1412. Massapequa Park, Village of, New York
- 1413. Melville Fire District, New York
- 1414. Mill Neck, Village of, New York
- 1415. Miller Place Fire District, New York
- 1416. Monroe, County of, New York
- 1417. Montgomery, County of, New York
- 1418. Mount Sinai Fire District, New York
- 1419. Nassau, County of, New York
- 1420. Nesconset Fire District, New York
- 1421. New Hyde Park, Village of, New York
- 1422. New York, City of, New York
- 1423. Niagara, County of, New York
- 1424. Nissequogue, Village of, New York
- 1425. North Hempstead, Town of, New York
- 1426. North Merrick Fire District, New York
- 1427. North Patchogue Fire District, New York
- 1428. Northport, Village of, New York
- 1429. Ogdensburg, City of, New York
- 1430. Old Westbury, Village of, New York
- 1431. Oneida, County of, New York
- 1432. Onondaga, County of, New York
- 1433. Ontario, County of, New York
- 1434. Orange, County of, New York
- 1435. Orangetown, Town of, New York
- 1436. Oswego, County of, New York
- 1437. Oyster Bay, Town of, New York
- 1438. Patchogue, Village of, New York
- 1439. Plattsburgh, City of, New York
- 1440. Poquott, Village of, New York
- 1441. Port Washington North, Village of, New York
- 1442. Port Washington Water District, New York
- 1443. Poughkeepsie, City of, New York
- 1444. Poughkeepsie, Town of, New York
- 1445. Ramapo, Town of, New York
- 1446. Rensselaer, County of, New York
- 1447. Ridge Fire District, New York
- 1448. Riverhead, Town of, New York
- 1449. Rochester, City of, New York
- 1450. Rome, City of, New York
- 1451. Rosalyn Water District, New York
- 1452. Saltaire, Village of, New York
- 1453. Saratoga, County of, New York
- 1454. Saratoga Springs, City of, New York
- 1455. Schenectady, City of, New York
- 1456. Schenectady, County of, New York
- 1457. Schoharie, County of, New York
- 1458. Schuyler, County of, New York
- 1459. Seneca, County of, New York
- 1460. Smithtown Fire District, New York
- 1461. Smithtown, Town of, New York
- 1462. South Farmingdale Fire District, New York

- 1463. Southampton, Town of, New York
- 1464. Southold, Town of, New York
- 1465. Southwestern Central School District, New York
- 1466. St. James Fire District, New York
- 1467. St. Lawrence, County of, New York
- 1468. Steuben, County of, New York
- 1469. Stewart Manor, Village of, New York
- 1470. Stony Brook Fire District, New York
- 1471. Stony Point, City of, New York
- 1472. Suffern, Village of, New York
- 1473. Suffolk, County of, New York
- 1474. Sullivan, County of, New York
- 1475. Syracuse, City of, New York
- 1476. The Branch, Village of, New York
- 1477. Tompkins, County of, New York
- 1478. Troy, City of, New York
- 1479. Ulster, County of, New York
- 1480. Uniondale Fire District, New York
- 1481. Utica, City of, New York
- 1482. Valley Stream, Village of, New York
- 1483. Washington, County of, New York
- 1484. West Hampton Dunes, Village of, New York
- 1485. West Haverstraw, Village of, New York
- 1486. Westbury, Village of, New York
- 1487. Westchester, County of, New York
- 1488. Wyoming, County of, New York
- 1489. Yonkers, City of, New York
- 1490. Alamance, County of, North Carolina
- 1491. Alexander, County of, North Carolina
- 1492. Anson, County of, North Carolina
- 1493. Ashe, County of, North Carolina
- 1494. Beaufort, County of, North Carolina
- 1495. Bladen, County of, North Carolina
- 1496. Brunswick, County of, North Carolina
- 1497. Buncombe, County of, North Carolina
- 1498. Burke, County of, North Carolina
- 1499. Cabarrus, County of, North Carolina
- 1500. Caldwell, County of, North Carolina
- 1501. Camden, County of, North Carolina
- 1502. Canton, Town of, North Carolina
- 1503. Carteret, County of, North Carolina
- 1504. Caswell, County of, North Carolina
- 1505. Catawba, County of, North Carolina
- 1506. Chatham, County of, North Carolina
- 1507. Cherokee, County of, North Carolina
- 1508. Cleveland, County of, North Carolina
- 1509. Columbus, County of, North Carolina
- 1510. Craven, County of, North Carolina
- 1511. Cumberland, County of, North Carolina
- 1512. Dare, County of, North Carolina
- 1513. Davidson, County of, North Carolina
- 1514. Davie, County of, North Carolina
- 1515. Duplin, County of, North Carolina
- 1516. Durham, County of, North Carolina
- 1517. Fayetteville, City of, North Carolina
- 1518. Forsyth, County of, North Carolina
- 1519. Franklin, County of, North Carolina
- 1520. Gaston, County of, North Carolina
- 1521. Granville, County of, North Carolina
- 1522. Greene, County of, North Carolina
- 1523. Greensboro, City of, North Carolina
- 1524. Guilford, County of, North Carolina
- 1525. Halifax, County of, North Carolina
- 1526. Haywood, County of, North Carolina
- 1527. Henderson, City of, North Carolina
- 1528. Hickory, City of, North Carolina
- 1529. Iredell, County of, North Carolina
- 1530. Jacksonville, City of, North Carolina
- 1531. Lenoir, County of, North Carolina
- 1532. Lincoln, County of, North Carolina
- 1533. Martin, County of, North Carolina
- 1534. McDowell, County of, North Carolina
- 1535. Mecklenburg, County of, North Carolina
- 1536. Mitchell, County of, North Carolina
- 1537. Moore, County of, North Carolina
- 1538. New Hanover, County of, North Carolina
- 1539. Onslow, County of, North Carolina
- 1540. Orange, County of, North Carolina

- 1541. Pamlico, County of, North Carolina
- 1542. Pasquotank, County of, North Carolina
- 1543. Person, County of, North Carolina
- 1544. Pitt, County of, North Carolina
- 1545. Randolph, County of, North Carolina
- 1546. Richmond, County of, North Carolina
- 1547. Robeson, County of, North Carolina
- 1548. Rockingham, County of, North Carolina
- 1549. Rowan, County of, North Carolina
- 1550. Rutherford, County of, North Carolina
- 1551. Sampson, County of, North Carolina
- 1552. Scotland, County of, North Carolina
- 1553. Surry, County of, North Carolina
- 1554. Vance, County of, North Carolina
- 1555. Watauga, County of, North Carolina
- 1556. Wayne, County of, North Carolina
- 1557. Wilkes, County of, North Carolina
- 1558. Wilmington, City of, North Carolina
- 1559. Winston-Salem, City of, North Carolina
- 1560. Barnes, County of, North Dakota
- 1561. Benson, County of, North Dakota
- 1562. Bismarck, City of, North Dakota
- 1563. Burleigh, County of, North Dakota
- 1564. Devils Lake, City of, North Dakota
- 1565. Dickey, County of, North Dakota
- 1566. Dunn, County of, North Dakota
- 1567. Eddy, County of, North Dakota
- 1568. Foster, County of, North Dakota
- 1569. Grand Forks, County of, North Dakota
- 1570. Lamoure, County of, North Dakota
- 1571. Lisbon, City of, North Dakota
- 1572. McKenzie, County of, North Dakota
- 1573. McLean, County of, North Dakota
- 1574. Mercer, County of, North Dakota
- 1575. Mountrail, County of, North Dakota
- 1576. Pembina, County of, North Dakota
- 1577. Pierce, County of, North Dakota
- 1578. Ramsey, County of, North Dakota
- 1579. Ransom, County of, North Dakota
- 1580. Richland, County of, North Dakota
- 1581. Rolette, County of, North Dakota
- 1582. Sargent, County of, North Dakota
- 1583. Stark, County of, North Dakota
- 1584. Towner, County of, North Dakota
- 1585. Walsh, County of, North Dakota
- 1586. Ward, County of, North Dakota
- 1587. Wells, County of, North Dakota
- 1588. Williams, County of, North Dakota
- 1589. Adams, County of, Ohio
- 1590. Akron, City of, Ohio/ Akron, (District Attorney of) City of, Ohio
- 1591. Allen, County of, Ohio
- 1592. Ashland, City of, Ohio
- 1593. Ashland, County of, Ohio
- 1594. Ashtabula, County of, Ohio
- 1595. Athens, County of, Ohio
- 1596. Auglaize, County of, Ohio
- 1597. Aurora, City of, Ohio
- 1598. Barberton, City of, Ohio
- 1599. Belmont, County of, Ohio
- 1600. Board of Education of Boardman Local Schools, Ohio
- 1601. Board of Education of Liberty Local Schools, Ohio
- 1602. Boston Heights, Village of, Ohio
- 1603. Boston, Township of, Ohio
- 1604. Broadview Heights, City of, Ohio
- 1605. Brooklyn Heights, Village of, Ohio
- 1606. Butler, County of, Ohio
- 1607. Champaign, County of, Ohio
- 1608. Cincinnati, City of, Ohio
- 1609. Clermont, County of, Ohio
- 1610. Cleveland, City of, Ohio/ Cleveland, (District Attorney of) City of, Ohio
- 1611. Clinton, County of, Ohio
- 1612. Clinton, Village of, Ohio
- 1613. Columbiana, County of, Ohio
- 1614. Copley, Township of, Ohio
- 1615. Coshocton, County of, Ohio
- 1616. Coventry, Township of, Ohio
- 1617. Crawford, County of, Ohio
- 1618. Cuyahoga, County of, Ohio/ Cuyahoga, (District Attorney of) County of, Ohio
- 1619. Cuyahoga Falls, City of, Ohio
- 1620. Darke, County of, Ohio

- 1621. Dayton, City of, Ohio
- 1622. Delaware, County of, Ohio
- 1623. East Cleveland, City of, Ohio
- 1624. Elyria, City of, Ohio
- 1625. Erie, County of, Ohio
- 1626. Euclid, City of, Ohio
- 1627. Fairfield, City of, Ohio
- 1628. Fairfield, County of, Ohio
- 1629. Fairlawn, City of, Ohio
- 1630. Fayette, County of, Ohio/ Fayette,  
(District Attorney of) County of,  
Ohio
- 1631. Findlay, City of, Ohio
- 1632. Franklin, County of, Ohio
- 1633. Fulton, County of, Ohio
- 1634. Gallia, County of, Ohio
- 1635. Garfield Heights, City of, Ohio
- 1636. Geauga, County of, Ohio
- 1637. Green, City of, Ohio
- 1638. Guernsey, County of, Ohio
- 1639. Hamilton, City of, Ohio
- 1640. Hamilton, County of, Ohio
- 1641. Hancock, County of, Ohio
- 1642. Harrison, County of, Ohio
- 1643. Hocking, County of, Ohio
- 1644. Huron, City of, Ohio
- 1645. Huron, County of, Ohio
- 1646. Ironton, City of, Ohio
- 1647. Jackson, County of, Ohio
- 1648. Jefferson, County of, Ohio
- 1649. Kent, City of, Ohio
- 1650. Knox, County of, Ohio
- 1651. Lake, County of, Ohio
- 1652. Lakemore, Village of, Ohio
- 1653. Lawrence, County of, Ohio
- 1654. Lebanon, City of, Ohio
- 1655. Lexington, Village of, Ohio
- 1656. Licking, County of, Ohio
- 1657. Lima, City of, Ohio
- 1658. Logan, County of, Ohio
- 1659. Lorain, City of, Ohio
- 1660. Lorain, County of, Ohio
- 1661. Lucas, County of, Ohio
- 1662. Lyndhurst, City of, Ohio
- 1663. Macedonia, City of, Ohio
- 1664. Marietta, City of, Ohio
- 1665. Marion, County of, Ohio
- 1666. Mayfield Heights, City of, Ohio
- 1667. Meigs, County of, Ohio
- 1668. Mercer, County of, Ohio
- 1669. Middletown, City of, Ohio
- 1670. Mogadore, Village of, Ohio
- 1671. Montgomery, (Board of County  
Commissioners of) County of, Ohio
- 1672. Munroe Falls, City of, Ohio
- 1673. Muskingum, County of, Ohio
- 1674. New Franklin, City of, Ohio
- 1675. Newburgh Heights, Village of, Ohio
- 1676. Noble, County of, Ohio
- 1677. North Olmsted, City of, Ohio
- 1678. North Ridgeville, City of, Ohio
- 1679. North Royalton, City of, Ohio
- 1680. Norton, City of, Ohio
- 1681. Olmsted Falls, City of, Ohio
- 1682. Ottawa, County of, Ohio
- 1683. Painesville, City of, Ohio
- 1684. Parma, City of, Ohio
- 1685. Parma Heights, City of, Ohio
- 1686. Peninsula, Village of, Ohio
- 1687. Pike, County of, Ohio
- 1688. Portage, County of, Ohio
- 1689. Portsmouth, City of, Ohio
- 1690. Ravenna, City of, Ohio
- 1691. Richfield, Village of, Ohio
- 1692. Ross, County of, Ohio
- 1693. Sandusky, County of, Ohio
- 1694. Scioto, County of, Ohio
- 1695. Seneca, County of, Ohio
- 1696. Seven Hills, City of, Ohio
- 1697. Shelby, County of, Ohio
- 1698. Silver Lake, Village of, Ohio
- 1699. Springfield, Township of, Ohio
- 1700. St. Marys, City of, Ohio
- 1701. Stark, County of, Ohio
- 1702. Stow, City of, Ohio
- 1703. Strongsville, City of, Ohio
- 1704. Summit, County of, Ohio/ Summit,  
(District Attorney of) County of,  
Ohio/ Summit, (Public Health  
District of) County of, Ohio
- 1705. Tallmadge, City of, Ohio
- 1706. Toledo, City of, Ohio



- 1707. Trumbull, County of, Ohio
- 1708. Valley Fire District, Ohio
- 1709. Van Wert, County of, Ohio
- 1710. Warren, City of, Ohio
- 1711. Warrensville Heights, City of, Ohio
- 1712. Washington, County of, Ohio
- 1713. Wayne, County of, Ohio
- 1714. Wickliffe, City of, Ohio
- 1715. Williams, County of, Ohio
- 1716. Wyandot, County of, Ohio
- 1717. Ada, City of, Oklahoma
- 1718. Altus, City of, Oklahoma
- 1719. Anadarko, City of, Oklahoma
- 1720. Atoka, (Board of County Commissioners of) County of, Oklahoma
- 1721. Beckham, (Board of County Commissioners of) County of, Oklahoma
- 1722. Bethany, City of, Oklahoma
- 1723. Broken Arrow, City of, Oklahoma
- 1724. Caddo, (Board of County Commissioners of) County of, Oklahoma
- 1725. Choctaw, (Board of County Commissioners of) County of, Oklahoma
- 1726. Cimarron, (Board of County Commissioners of) County of, Oklahoma
- 1727. Cleveland, (Board of County Commissioners of) County of, Oklahoma
- 1728. Coal, (Board of County Commissioners of) County of, Oklahoma
- 1729. Comanche, County of, Oklahoma
- 1730. Craig, (Board of County Commissioners of) County of, Oklahoma
- 1731. Creek, (Board of County Commissioners of) County of, Oklahoma
- 1732. Custer, (Board of County Commissioners of) County of, Oklahoma
- 1733. Delaware, County of, Oklahoma
- 1734. Dewey, (Board of County Commissioners of) County of, Oklahoma
- 1735. Edmond, City of, Oklahoma
- 1736. El Reno, City of, Oklahoma
- 1737. Elk City, City of, Oklahoma
- 1738. Enid, City of, Oklahoma
- 1739. Garvin, County of, Oklahoma
- 1740. Grady, (Board of County Commissioners of) County of, Oklahoma
- 1741. Greer, (Board of County Commissioners of) County of, Oklahoma
- 1742. Guthrie, City of, Oklahoma
- 1743. Harmon, (Board of County Commissioners of) County of, Oklahoma
- 1744. Harper, (Board of County Commissioners of) County of, Oklahoma
- 1745. Haskell, (Board of County Commissioners of) County of, Oklahoma
- 1746. Hughes, (Board of County Commissioners of) County of, Oklahoma
- 1747. Jackson, (Board of County Commissioners of) County of, Oklahoma
- 1748. Jefferson, (Board of County Commissioners of) County of, Oklahoma
- 1749. Jenks, City of, Oklahoma
- 1750. Johnston, (Board of County Commissioners of) County of, Oklahoma
- 1751. Kay, (Board of County Commissioners of) County of, Oklahoma
- 1752. Kiowa, (Board of County Commissioners of) County of, Oklahoma

- 1753. Latimer, (Board of County Commissioners of) County of, Oklahoma
- 1754. Lawton, City of, Oklahoma
- 1755. LeFlore, (Board of County Commissioners of) County of, Oklahoma
- 1756. Lincoln, (Board of County Commissioners of) County of, Oklahoma
- 1757. Logan, (Board of County Commissioners of) County of, Oklahoma
- 1758. Love, (Board of County Commissioners of) County of, Oklahoma
- 1759. Major, (Board of County Commissioners of) County of, Oklahoma
- 1760. Mayes, (Board of County Commissioners of) County of, Oklahoma
- 1761. McClain, County of, Oklahoma
- 1762. McCurtain, (Board of County Commissioners of) County of, Oklahoma
- 1763. Midwest City, City of, Oklahoma
- 1764. Muskogee, City of, Oklahoma
- 1765. Muskogee, (Board of County Commissioners of) County of, Oklahoma
- 1766. Mustang, City of, Oklahoma
- 1767. Noble, (Board of County Commissioners of) County of, Oklahoma
- 1768. Nowata, (Board of County Commissioners of) County of, Oklahoma
- 1769. Okfuskee, County of, Oklahoma
- 1770. Oklahoma City, City of, Oklahoma
- 1771. Oklahoma, County of, Oklahoma
- 1772. Okmulgee, (Board of County Commissioners of) County of, Oklahoma
- 1773. Osage, County of, Oklahoma
- 1774. Ottawa, County of, Oklahoma
- 1775. Owasso, City of, Oklahoma
- 1776. Pawnee, County of, Oklahoma
- 1777. Payne, (Board of County Commissioners of) County of, Oklahoma
- 1778. Pittsburg, (Board of County Commissioners of) County of, Oklahoma
- 1779. Ponca City, City of, Oklahoma
- 1780. Pottawatomie, (Board of County Commissioners of) County of, Oklahoma
- 1781. Roger Mills, (Board of County Commissioners of) County of, Oklahoma
- 1782. Rogers, (Board of County Commissioners of) County of, Oklahoma
- 1783. Seminole, City of, Oklahoma
- 1784. Seminole, County of, Oklahoma
- 1785. Shawnee, City of, Oklahoma
- 1786. Stephens, (Board of County Commissioners of) County of, Oklahoma
- 1787. Texas, (Board of County Commissioners of) County of, Oklahoma
- 1788. Tillman, County of, Oklahoma
- 1789. Tulsa, City of, Oklahoma
- 1790. Tulsa, County of, Oklahoma
- 1791. Washington, (Board of County Commissioners of) County of, Oklahoma
- 1792. Woods, (Board of County Commissioners of) County of, Oklahoma
- 1793. Woodward, (Board of County Commissioners of) County of, Oklahoma
- 1794. Yukon, City of, Oklahoma
- 1795. Clackamas, County of, Oregon
- 1796. Clatsop, County of, Oregon
- 1797. Columbia, County of, Oregon
- 1798. Coos, County of, Oregon
- 1799. Jackson, County of, Oregon
- 1800. Josephine, County of, Oregon

- 1801. Lane, County of, Oregon
- 1802. Multnomah, County of, Oregon
- 1803. Portland, City of, Oregon
- 1804. Washington, County of, Oregon
- 1805. Yamhill, County of, Oregon
- 1806. Adams, County of, Pennsylvania
- 1807. Allegheny, (District Attorney of) County of, Pennsylvania
- 1808. Armstrong, County of, Pennsylvania
- 1809. Beaver, County of, Pennsylvania/ Beaver, (District Attorney of) County of, Pennsylvania
- 1810. Bedford, County of, Pennsylvania
- 1811. Bensalem, Township of, Pennsylvania
- 1812. Berks, (District Attorney of) County of, Pennsylvania
- 1813. Bradford, County of, Pennsylvania
- 1814. Bristol, Township of, Pennsylvania
- 1815. Bucks, County of, Pennsylvania/ Bucks, (District Attorney of) County of, Pennsylvania
- 1816. Cambria, County of, Pennsylvania
- 1817. Carbon, County of, Pennsylvania
- 1818. Chester, (District Attorney of) County of, Pennsylvania
- 1819. Clarion, County of, Pennsylvania
- 1820. Clearfield, (District Attorney of) County of, Pennsylvania
- 1821. Clinton, County of, Pennsylvania
- 1822. Coatesville, City of, Pennsylvania
- 1823. Columbia, County of, Pennsylvania
- 1824. Dauphin, County of, Pennsylvania/ Dauphin, (District Attorney of) County of, Pennsylvania
- 1825. Delaware, County of, Pennsylvania/ Delaware, (District Attorney of) County of, Pennsylvania
- 1826. Edwardsville, Borough of, Pennsylvania
- 1827. Erie, County of, Pennsylvania/ Erie, (District Attorney of) County of, Pennsylvania
- 1828. Exeter, Township of, Pennsylvania
- 1829. Fairview, Township of, Pennsylvania
- 1830. Fayette, County of, Pennsylvania
- 1831. Forty Fort, Borough of, Pennsylvania
- 1832. Franklin, County of, Pennsylvania
- 1833. Greene, County of, Pennsylvania
- 1834. Hanover, Township of, Pennsylvania
- 1835. Hazleton, City of, Pennsylvania
- 1836. Huntington, County of, Pennsylvania
- 1837. Indiana, County of, Pennsylvania
- 1838. Kingston, City of, Pennsylvania
- 1839. Lackawanna, County of, Pennsylvania
- 1840. Lawrence, County of, Pennsylvania/ Lawrence, (District Attorney of) County of, Pennsylvania
- 1841. Lehigh, County of, Pennsylvania/ Lehigh, (District Attorney of) County of, Pennsylvania
- 1842. Lock Haven, City of, Pennsylvania
- 1843. Lower Makefield, Township of, Pennsylvania
- 1844. Luzerne, County of, Pennsylvania
- 1845. Lycoming, County of, Pennsylvania
- 1846. Mercer, County of, Pennsylvania
- 1847. Middletown, Township of, Pennsylvania
- 1848. Monroe, County of, Pennsylvania
- 1849. Morrisville, Borough of, Pennsylvania
- 1850. Nanticoke, City of, Pennsylvania
- 1851. Newtown, Township of, Pennsylvania
- 1852. Norristown, Municipality of, Pennsylvania
- 1853. Northampton, (District Attorney of) County of, Pennsylvania
- 1854. Northumberland, County of, Pennsylvania
- 1855. Philadelphia, City of/ County of, Pennsylvania/ Philadelphia, (District Attorney of) City of/ County of, Pennsylvania
- 1856. Pike, County of, Pennsylvania
- 1857. Plains Township, Township of, Pennsylvania
- 1858. Schuylkill, County of, Pennsylvania
- 1859. Sugar Notch, Borough of, Pennsylvania

- 1860. Tioga, County of, Pennsylvania
- 1861. Warminster, Township of, Pennsylvania
- 1862. Warrington, Township of, Pennsylvania
- 1863. Washington, County of, Pennsylvania
- 1864. West Norriton, Township of, Pennsylvania
- 1865. West Pittston, Borough of, Pennsylvania
- 1866. Westmoreland, County of, Pennsylvania/ Westmoreland, (District Attorney of) County of, Pennsylvania
- 1867. Wilkes-Barre, City of, Pennsylvania
- 1868. Wilkes-Barre, Township of, Pennsylvania
- 1869. Wright, Township of, Pennsylvania
- 1870. Wyoming, Borough of, Pennsylvania
- 1871. Wyoming, County of, Pennsylvania/ Wyoming, (District Attorney of) County of, Pennsylvania
- 1872. Canovanas, Municipality of, Puerto Rico
- 1873. Cayey, Municipality of, Puerto Rico
- 1874. Guayanilla, Municipality of, Puerto Rico
- 1875. Juncos, Municipality of, Puerto Rico
- 1876. Loiza, Municipality of, Puerto Rico
- 1877. Rio Grande, Municipality of, Puerto Rico
- 1878. Sabana Grande, Municipality of, Puerto Rico
- 1879. San Juan, Municipality of, Puerto Rico
- 1880. Vega Alta, Municipality of, Puerto Rico
- 1881. Yabucoa, Municipality of, Puerto Rico
- 1882. Burrillville, Town of, Rhode Island
- 1883. Central Falls, City of, Rhode Island
- 1884. Charlestown, Town of, Rhode Island
- 1885. Coventry, Town of, Rhode Island
- 1886. Cranston, City of, Rhode Island
- 1887. Cumberland, Town of, Rhode Island
- 1888. East Greenwich, Town of, Rhode Island
- 1889. East Providence, City of, Rhode Island
- 1890. Foster, Town of, Rhode Island
- 1891. Glocester, Town of, Rhode Island
- 1892. Hopkinton, Town of, Rhode Island
- 1893. Jamestown, Town of, Rhode Island
- 1894. Johnston, Town of, Rhode Island
- 1895. Middletown, Town of, Rhode Island
- 1896. Narragansett, Town of, Rhode Island
- 1897. Newport, City of, Rhode Island
- 1898. North Kingstown, Town of, Rhode Island
- 1899. North Providence, Town of, Rhode Island
- 1900. Pawtucket, City of, Rhode Island
- 1901. Portsmouth, Town of, Rhode Island
- 1902. Richmond, Town of, Rhode Island
- 1903. Scituate, Town of, Rhode Island
- 1904. Smithfield, Town of, Rhode Island
- 1905. South Kingstown, Town of, Rhode Island
- 1906. Warwick, City of, Rhode Island
- 1907. West Greenwich, Town of, Rhode Island
- 1908. West Warwick, Town of, Rhode Island
- 1909. Westerly, Town of, Rhode Island
- 1910. Woonsocket, City of, Rhode Island
- 1911. Abbeville, County of, South Carolina
- 1912. Aiken, County of, South Carolina
- 1913. Allendale, County of, South Carolina
- 1914. Anderson, County of, South Carolina
- 1915. Bamberg, County of, South Carolina
- 1916. Barnwell, County of, South Carolina
- 1917. Beaufort, County of, South Carolina
- 1918. Berkeley, County of, South Carolina
- 1919. Calhoun, County of, South Carolina
- 1920. Charleston, City of, South Carolina
- 1921. Charleston, County of, South Carolina
- 1922. Cherokee, County of, South Carolina
- 1923. Chester, City of, South Carolina
- 1924. Chester, County of, South Carolina

- 1925. Chesterfield, County of, South Carolina
- 1926. Clarendon, County of, South Carolina
- 1927. Colleton, County of, South Carolina
- 1928. Dillon, County of, South Carolina
- 1929. Dorchester, County of, South Carolina
- 1930. Edgefield, County of, South Carolina
- 1931. Fairfield, County of, South Carolina
- 1932. Florence, County of, South Carolina
- 1933. Georgetown, City of, South Carolina
- 1934. Georgetown, County of, South Carolina
- 1935. Greenville, County of, South Carolina
- 1936. Greenwood, County of, South Carolina
- 1937. Hampton, County of, South Carolina
- 1938. Horry, County of, South Carolina
- 1939. Jasper, County of, South Carolina
- 1940. Kershaw, County of, South Carolina
- 1941. Lancaster, County of, South Carolina
- 1942. Laurens, County of, South Carolina
- 1943. Lee, County of, South Carolina
- 1944. Lexington, County of, South Carolina
- 1945. Marion, County of, South Carolina
- 1946. Marlboro, County of, South Carolina
- 1947. McCormick, County of, South Carolina
- 1948. Mt. Pleasant, Town of, South Carolina
- 1949. Myrtle Beach, City of, South Carolina
- 1950. Newberry, County of, South Carolina
- 1951. North Charleston, City of, South Carolina
- 1952. Oconee, County of, South Carolina
- 1953. Orangeburg, City of, South Carolina
- 1954. Orangeburg, County of, South Carolina
- 1955. Pickens, County of, South Carolina
- 1956. Richland, County of, South Carolina
- 1957. Saluda, County of, South Carolina
- 1958. Spartanburg, County of, South Carolina
- 1959. Summerville, Town of, South Carolina
- 1960. Sumter, County of, South Carolina
- 1961. Union, County of, South Carolina
- 1962. Williamsburg, County of, South Carolina
- 1963. York, County of, South Carolina
- 1964. Pennington, County of, South Dakota
- 1965. Alexandria, Town of, Tennessee
- 1966. Algood, City of, Tennessee
- 1967. Anderson, County of, Tennessee
- 1968. Arlington, Town of, Tennessee
- 1969. Baxter, Town of, Tennessee
- 1970. Bedford, County of, Tennessee
- 1971. Bledsoe, County of, Tennessee
- 1972. Blount, County of, Tennessee
- 1973. Bradley, County of, Tennessee
- 1974. Campbell, County of, Tennessee
- 1975. Celina, City of, Tennessee
- 1976. Centertown, Town of, Tennessee
- 1977. Centreville, County of, Tennessee
- 1978. Claiborne, County of, Tennessee
- 1979. Clarksville, City of, Tennessee
- 1980. Clay, County of, Tennessee
- 1981. Clifton, City of, Tennessee
- 1982. Cocke, County of, Tennessee
- 1983. Columbia, City of, Tennessee
- 1984. Cookeville, City of, Tennessee
- 1985. Cornersville, Town of, Tennessee
- 1986. Crossville, City of, Tennessee
- 1987. Cumberland, County of, Tennessee
- 1988. Dekalb, County of, Tennessee
- 1989. Eagleville, City of, Tennessee
- 1990. Fayetteville, City of, Tennessee
- 1991. Fentress, County of, Tennessee
- 1992. Franklin, County of, Tennessee
- 1993. Gatlinburg, City of, Tennessee
- 1994. Giles, County of, Tennessee
- 1995. Grainger, County of, Tennessee
- 1996. Greene, County of, Tennessee
- 1997. Grundy, County of, Tennessee
- 1998. Hamblen County Board of Education, Tennessee

- 1999. Hamilton, County of, Tennessee
- 2000. Hancock County Board of Education, Tennessee
- 2001. Hawkins, County of, Tennessee
- 2002. Haywood, County of, Tennessee
- 2003. Henderson, County of, Tennessee
- 2004. Jefferson, County of, Tennessee
- 2005. Knox, County of, Tennessee
- 2006. Knoxville, City of, Tennessee
- 2007. La Vergene, City of, Tennessee
- 2008. Lauderdale, County of, Tennessee
- 2009. Lewisburg, City of, Tennessee
- 2010. Lexington, City of, Tennessee
- 2011. Loudon, County of, Tennessee
- 2012. Madison, County of, Tennessee
- 2013. Marion, County of, Tennessee
- 2014. Marshall, County of, Tennessee
- 2015. McMinn, County of, Tennessee
- 2016. Meigs, County of, Tennessee
- 2017. Millington, City of, Tennessee
- 2018. Monroe, County of, Tennessee
- 2019. Montgomery, County of, Tennessee
- 2020. Moore, County of, Tennessee
- 2021. Mount Pleasant, City of, Tennessee
- 2022. Murfreesboro, City of, Tennessee
- 2023. Pickett, County of, Tennessee
- 2024. Polk, County of, Tennessee
- 2025. Putnam, County of, Tennessee
- 2026. Rhea, County of, Tennessee
- 2027. Roane, County of, Tennessee
- 2028. Rutherford, County of, Tennessee
- 2029. Rutledge, City of, Tennessee
- 2030. Scott, County of, Tennessee
- 2031. Sequatchie, County of, Tennessee
- 2032. Sevier, County of, Tennessee
- 2033. Shelbyville, City of, Tennessee
- 2034. Smith, County of, Tennessee
- 2035. Smithville, City of, Tennessee
- 2036. Sparta, City of, Tennessee
- 2037. Spencer, City of, Tennessee
- 2038. Spring Hill, City of, Tennessee
- 2039. Union, County of, Tennessee
- 2040. Van Buren, County of, Tennessee
- 2041. Warren, County of, Tennessee
- 2042. Wartrace, Town of, Tennessee
- 2043. Washington, County of, Tennessee
- 2044. Wayne, County of, Tennessee
- 2045. White, County of, Tennessee
- 2046. Williamson, County of, Tennessee
- 2047. Angelina, County of, Texas
- 2048. Bailey, County of, Texas
- 2049. Bexar, County of, Texas
- 2050. Bowie, Town of, Texas
- 2051. Brazos, County of, Texas
- 2052. Burleson, County of, Texas
- 2053. Cherokee, County of, Texas
- 2054. Childress, County of, Texas
- 2055. Clay, County of, Texas
- 2056. Coryell, County of, Texas
- 2057. Dallas, County of, Texas
- 2058. Duval, County of, Texas
- 2059. Eagle Pass, City of, Texas
- 2060. Ellis, County of, Texas
- 2061. Freestone, County of, Texas
- 2062. Henderson, County of, Texas
- 2063. Jim Hogg, County of, Texas
- 2064. Jim Wells, County of, Texas
- 2065. Johnson, County of, Texas
- 2066. Jones, County of, Texas
- 2067. Kaufman, County of, Texas
- 2068. Kendall, County of, Texas
- 2069. Kleberg, County of, Texas
- 2070. Lamar, County of, Texas
- 2071. Laredo, City of, Texas
- 2072. Maverick, County of, Texas
- 2073. McLennan, County of, Texas
- 2074. Montgomery, County of, Texas
- 2075. Nolan, County of, Texas
- 2076. Polk, County of, Texas
- 2077. Rockwall, County of, Texas
- 2078. Rusk, County of, Texas
- 2079. San Antonio, City of, Texas
- 2080. Smith, County of, Texas
- 2081. Stephens, County of, Texas
- 2082. Tarrant, County of, Texas
- 2083. Titus, County of, Texas
- 2084. Upshur, County of, Texas
- 2085. Webb, County of, Texas
- 2086. Wichita, County of, Texas
- 2087. Williamson, County of, Texas
- 2088. Zavala, County of, Texas
- 2089. Beaver, County of, Utah

- 2090. Cache, County of, Utah
- 2091. Daggett, County of, Utah
- 2092. Duchesne, County of, Utah
- 2093. Emery, County of, Utah
- 2094. Garfield, County of, Utah
- 2095. Juab, County of, Utah
- 2096. Kane, County of, Utah
- 2097. Piute, County of, Utah
- 2098. Rich, County of, Utah
- 2099. Salt Lake, County of, Utah
- 2100. Sevier, County of, Utah
- 2101. Summit, County of, Utah
- 2102. Tooele, County of, Utah
- 2103. Uintah, County of, Utah
- 2104. Utah, County of, Utah
- 2105. Wasatch, County of, Utah
- 2106. Washington, County of, Utah
- 2107. Wayne, County of, Utah
- 2108. Weber, County of, Utah
- 2109. Bennington, Town of, Vermont
- 2110. St. Albans, City of, Vermont
- 2111. Accomack, County of, Virginia
- 2112. Alexandria, City of, Virginia
- 2113. Alleghany, County of, Virginia
- 2114. Amherst, County of, Virginia
- 2115. Arlington, County of, Virginia
- 2116. Botetourt, County of, Virginia
- 2117. Bristol, City of, Virginia
- 2118. Buena Vista, City of, Virginia
- 2119. Charlotte, County of, Virginia
- 2120. Chesapeake, City of, Virginia
- 2121. Chesterfield, County of, Virginia
- 2122. Covington, City of, Virginia
- 2123. Culpeper, County of, Virginia
- 2124. Cumberland, County of, Virginia
- 2125. Danville, City of, Virginia
- 2126. Dickenson, County of, Virginia
- 2127. Dinwiddie, County of, Virginia
- 2128. Emporia, City of, Virginia
- 2129. Fairfax, City of, Virginia
- 2130. Fairfax, County of, Virginia
- 2131. Fauquier, County of, Virginia
- 2132. Floyd, County of, Virginia
- 2133. Franklin, County of, Virginia
- 2134. Frederick, County of, Virginia
- 2135. Fredericksburg, City of, Virginia
- 2136. Galax, City of, Virginia
- 2137. Giles, County of, Virginia
- 2138. Goochland, County of, Virginia
- 2139. Greensville, County of, Virginia
- 2140. Halifax, County of, Virginia
- 2141. Henrico, County of, Virginia
- 2142. Henry, County of, Virginia
- 2143. Hopewell, City of, Virginia
- 2144. Isle of Wight, County of, Virginia
- 2145. King and Queen, County of, Virginia
- 2146. Lee, County of, Virginia
- 2147. Lexington, City of, Virginia
- 2148. Loudoun, County of, Virginia
- 2149. Louisa, County of, Virginia
- 2150. Madison, County of, Virginia
- 2151. Mecklenburg, County of, Virginia
- 2152. Montgomery, County of, Virginia
- 2153. Norfolk, City of, Virginia
- 2154. Northampton, County of, Virginia
- 2155. Northumberland, County of, Virginia
- 2156. Norton, City of, Virginia
- 2157. Page, County of, Virginia
- 2158. Patrick, County of, Virginia
- 2159. Pittsylvania, County of, Virginia
- 2160. Prince George, County of, Virginia
- 2161. Prince William, County of, Virginia
- 2162. Pulaski, County of, Virginia
- 2163. Radford, City of, Virginia
- 2164. Richmond, City of, Virginia
- 2165. Richmond, County of, Virginia
- 2166. Roanoke, City of, Virginia
- 2167. Roanoke, County of, Virginia
- 2168. Rockbridge, County of, Virginia
- 2169. Russell, County of, Virginia
- 2170. Salem, City of, Virginia
- 2171. Scott, County of, Virginia
- 2172. Shenandoah, County of, Virginia
- 2173. Smyth, County of, Virginia
- 2174. Stafford, County of, Virginia
- 2175. Tazewell, County of, Virginia
- 2176. Virginia Beach, City of, Virginia
- 2177. Warren, County of, Virginia
- 2178. Washington, County of, Virginia
- 2179. Waynesboro, City of, Virginia
- 2180. Westmoreland, County of, Virginia
- 2181. Winchester, City of, Virginia

- 2182. Wise, County of, Virginia
- 2183. Wythe, County of, Virginia
- 2184. Bainbridge Island, City of, Washington
- 2185. Chelan, County of, Washington
- 2186. Clallam, County of, Washington
- 2187. Everett, City of, Washington
- 2188. Franklin, County of, Washington
- 2189. Island, County of, Washington
- 2190. Jefferson, County of, Washington
- 2191. Kitsap, County of, Washington
- 2192. Lewis, County of, Washington
- 2193. Pierce, County of, Washington
- 2194. Snohomish, County of, Washington
- 2195. Tacoma, City of, Washington
- 2196. Walla Walla, County of, Washington
- 2197. Whitman, County of, Washington
- 2198. Adams, County of, Wisconsin
- 2199. Ashland, County of, Wisconsin
- 2200. Barron, County of, Wisconsin
- 2201. Bayfield, County of, Wisconsin
- 2202. Brown, County of, Wisconsin
- 2203. Buffalo, County of, Wisconsin
- 2204. Burnett, County of, Wisconsin
- 2205. Calumet, County of, Wisconsin
- 2206. Chippewa, County of, Wisconsin
- 2207. Clark, County of, Wisconsin
- 2208. Columbia, County of, Wisconsin
- 2209. Crawford, County of, Wisconsin
- 2210. Dane, County of, Wisconsin
- 2211. Dodge, County of, Wisconsin
- 2212. Door, County of, Wisconsin
- 2213. Douglas, County of, Wisconsin
- 2214. Dunn, County of, Wisconsin
- 2215. Eau Claire, County of, Wisconsin
- 2216. Florence, County of, Wisconsin
- 2217. Fond du Lac, County of, Wisconsin
- 2218. Forest, County of, Wisconsin
- 2219. Grant, County of, Wisconsin
- 2220. Green, County of, Wisconsin
- 2221. Green Lake, County of, Wisconsin
- 2222. Iowa, County of, Wisconsin
- 2223. Iron, County of, Wisconsin
- 2224. Jackson, County of, Wisconsin
- 2225. Jefferson, County of, Wisconsin
- 2226. Juneau, County of, Wisconsin
- 2227. Kenosha, City of, Wisconsin
- 2228. Kenosha, County of, Wisconsin
- 2229. Kewaunee, County of, Wisconsin
- 2230. La Crosse, County of, Wisconsin
- 2231. Lafayette, County of, Wisconsin
- 2232. Langlade, County of, Wisconsin
- 2233. Lincoln, County of, Wisconsin
- 2234. Manitowoc, County of, Wisconsin
- 2235. Marathon, County of, Wisconsin
- 2236. Marinette, County of, Wisconsin
- 2237. Marquette, County of, Wisconsin
- 2238. Menominee, County of, Wisconsin
- 2239. Milwaukee, City of, Wisconsin
- 2240. Milwaukee, County of, Wisconsin
- 2241. Monroe, County of, Wisconsin
- 2242. Oconto, County of, Wisconsin
- 2243. Oneida, County of, Wisconsin
- 2244. Outagamie, County of, Wisconsin
- 2245. Ozaukee, County of, Wisconsin
- 2246. Pepin, County of, Wisconsin
- 2247. Pierce, County of, Wisconsin
- 2248. Pleasant Prairie, Village of, Wisconsin
- 2249. Portage, County of, Wisconsin
- 2250. Price, County of, Wisconsin
- 2251. Racine, County of, Wisconsin
- 2252. Richland, County of, Wisconsin
- 2253. Rock, County of, Wisconsin
- 2254. Rusk, County of, Wisconsin
- 2255. Sauk, County of, Wisconsin
- 2256. Sawyer, County of, Wisconsin
- 2257. Shawano, County of, Wisconsin
- 2258. Sheboygan, County of, Wisconsin
- 2259. St. Croix, County of, Wisconsin
- 2260. Taylor, County of, Wisconsin
- 2261. Trempealeau, County of, Wisconsin
- 2262. Vernon, County of, Wisconsin
- 2263. Vilas, County of, Wisconsin
- 2264. Walworth, County of, Wisconsin
- 2265. Washburn, County of, Wisconsin
- 2266. Washington, County of, Wisconsin
- 2267. Waukesha, County of, Wisconsin
- 2268. Waupaca, County of, Wisconsin
- 2269. Waushara, County of, Wisconsin
- 2270. Winnebago, County of, Wisconsin
- 2271. Wood, County of, Wisconsin



- 2272. Carbon, County of, Wyoming
- 2273. Casper, City of, Wyoming
- 2274. Cheyenne, City of, Wyoming
- 2275. Green River, City of, Wyoming
- 2276. Riverton, City of, Wyoming
- 2277. Rock Springs, City of, Wyoming
- 2278. Sweetwater, County of, Wyoming

**EXHIBIT D**

**[Intentionally Omitted]**

## **EXHIBIT E**

### **List of Opioid Remediation Uses**

#### **Schedule A Core Strategies**

Settling States and Participating Subdivisions listed on Exhibit G may choose from among the abatement strategies listed in Schedule B. However, priority may be given to the following core abatement strategies (“*Core Strategies*”).<sup>1</sup>

#### **A. NALOXONE OR OTHER FDA-APPROVED DRUG TO REVERSE OPIOID OVERDOSES**

1. Expand training for first responders, schools, community support groups and families; and
2. Increase distribution to individuals who are uninsured or whose insurance does not cover the needed service.

#### **B. MEDICATION-ASSISTED TREATMENT (“MAT”) DISTRIBUTION AND OTHER OPIOID-RELATED TREATMENT**

1. Increase distribution of MAT to individuals who are uninsured or whose insurance does not cover the needed service;
2. Provide education to school-based and youth-focused programs that discourage or prevent misuse;
3. Provide MAT education and awareness training to healthcare providers, EMTs, law enforcement, and other first responders; and
4. Provide treatment and recovery support services such as residential and inpatient treatment, intensive outpatient treatment, outpatient therapy or counseling, and recovery housing that allow or integrate medication and with other support services.

---

<sup>1</sup> As used in this Schedule A, words like “expand,” “fund,” “provide” or the like shall not indicate a preference for new or existing programs.

**C. PREGNANT & POSTPARTUM WOMEN**

1. Expand Screening, Brief Intervention, and Referral to Treatment (“*SBIRT*”) services to non-Medicaid eligible or uninsured pregnant women;
2. Expand comprehensive evidence-based treatment and recovery services, including MAT, for women with cooccurring Opioid Use Disorder (“*OUD*”) and other Substance Use Disorder (“*SUD*”)/Mental Health disorders for uninsured individuals for up to 12 months postpartum; and
3. Provide comprehensive wrap-around services to individuals with OUD, including housing, transportation, job placement/training, and childcare.

**D. EXPANDING TREATMENT FOR NEONATAL ABSTINENCE SYNDROME (“*NAS*”)**

1. Expand comprehensive evidence-based and recovery support for NAS babies;
2. Expand services for better continuum of care with infant-need dyad; and
3. Expand long-term treatment and services for medical monitoring of NAS babies and their families.

**E. EXPANSION OF WARM HAND-OFF PROGRAMS AND RECOVERY SERVICES**

1. Expand services such as navigators and on-call teams to begin MAT in hospital emergency departments;
2. Expand warm hand-off services to transition to recovery services;
3. Broaden scope of recovery services to include co-occurring SUD or mental health conditions;
4. Provide comprehensive wrap-around services to individuals in recovery, including housing, transportation, job placement/training, and childcare; and
5. Hire additional social workers or other behavioral health workers to facilitate expansions above.

**F. TREATMENT FOR INCARCERATED POPULATION**

1. Provide evidence-based treatment and recovery support, including MAT for persons with OUD and co-occurring SUD/MH disorders within and transitioning out of the criminal justice system; and
2. Increase funding for jails to provide treatment to inmates with OUD.

**G. PREVENTION PROGRAMS**

1. Funding for media campaigns to prevent opioid use (similar to the FDA’s “Real Cost” campaign to prevent youth from misusing tobacco);
2. Funding for evidence-based prevention programs in schools;
3. Funding for medical provider education and outreach regarding best prescribing practices for opioids consistent with CDC guidelines, including providers at hospitals (academic detailing);
4. Funding for community drug disposal programs; and
5. Funding and training for first responders to participate in prearrest diversion programs, post-overdose response teams, or similar strategies that connect at-risk individuals to behavioral health services and supports.

**H. EXPANDING SYRINGE SERVICE PROGRAMS**

1. Provide comprehensive syringe services programs with more wrap-around services, including linkage to OUD treatment, access to sterile syringes and linkage to care and treatment of infectious diseases.

**I. EVIDENCE-BASED DATA COLLECTION AND RESEARCH ANALYZING THE EFFECTIVENESS OF THE ABATEMENT STRATEGIES WITHIN THE STATE**

## Schedule B Approved Uses

Support treatment of Opioid Use Disorder (OUD) and any co-occurring Substance Use Disorder or Mental Health (SUD/MH) conditions through evidence-based or evidence-informed programs or strategies that may include, but are not limited to, the following:

PART ONE: TREATMENT
---------------------

### A. **TREAT OPIOID USE DISORDER (OUD)**

Support treatment of Opioid Use Disorder (“*OUD*”) and any co-occurring Substance Use Disorder or Mental Health (“*SUD/MH*”) conditions through evidence-based or evidence-informed programs or strategies that may include, but are not limited to, those that:<sup>2</sup>

1. Expand availability of treatment for OUD and any co-occurring SUD/MH conditions, including all forms of Medication-Assisted Treatment (“*MAT*”) approved by the U.S. Food and Drug Administration.
2. Support and reimburse evidence-based services that adhere to the American Society of Addiction Medicine (“*ASAM*”) continuum of care for OUD and any co-occurring SUD/MH conditions.
3. Expand telehealth to increase access to treatment for OUD and any co-occurring SUD/MH conditions, including *MAT*, as well as counseling, psychiatric support, and other treatment and recovery support services.
4. Improve oversight of Opioid Treatment Programs (“*OTPs*”) to assure evidence-based or evidence-informed practices such as adequate methadone dosing and low threshold approaches to treatment.
5. Support mobile intervention, treatment, and recovery services, offered by qualified professionals and service providers, such as peer recovery coaches, for persons with OUD and any co-occurring SUD/MH conditions and for persons who have experienced an opioid overdose.
6. Provide treatment of trauma for individuals with OUD (*e.g.*, violence, sexual assault, human trafficking, or adverse childhood experiences) and family members (*e.g.*, surviving family members after an overdose or overdose fatality), and training of health care personnel to identify and address such trauma.
7. Support evidence-based withdrawal management services for people with OUD and any co-occurring mental health conditions.

---

<sup>2</sup> As used in this Schedule B, words like “expand,” “fund,” “provide” or the like shall not indicate a preference for new or existing programs.

8. Provide training on MAT for health care providers, first responders, students, or other supporting professionals, such as peer recovery coaches or recovery outreach specialists, including telementoring to assist community-based providers in rural or underserved areas.
9. Support workforce development for addiction professionals who work with persons with OUD and any co-occurring SUD/MH conditions.
10. Offer fellowships for addiction medicine specialists for direct patient care, instructors, and clinical research for treatments.
11. Offer scholarships and supports for behavioral health practitioners or workers involved in addressing OUD and any co-occurring SUD/MH or mental health conditions, including, but not limited to, training, scholarships, fellowships, loan repayment programs, or other incentives for providers to work in rural or underserved areas.
12. Provide funding and training for clinicians to obtain a waiver under the federal Drug Addiction Treatment Act of 2000 (“*DATA 2000*”) to prescribe MAT for OUD, and provide technical assistance and professional support to clinicians who have obtained a *DATA 2000* waiver.
13. Disseminate web-based training curricula, such as the American Academy of Addiction Psychiatry’s Provider Clinical Support Service-Opioids web-based training curriculum and motivational interviewing.
14. Develop and disseminate new curricula, such as the American Academy of Addiction Psychiatry’s Provider Clinical Support Service for Medication-Assisted Treatment.

**B. SUPPORT PEOPLE IN TREATMENT AND RECOVERY**

Support people in recovery from OUD and any co-occurring SUD/MH conditions through evidence-based or evidence-informed programs or strategies that may include, but are not limited to, the programs or strategies that:

1. Provide comprehensive wrap-around services to individuals with OUD and any cooccurring SUD/MH conditions, including housing, transportation, education, job placement, job training, or childcare.
2. Provide the full continuum of care of treatment and recovery services for OUD and any co-occurring SUD/MH conditions, including supportive housing, peer support services and counseling, community navigators, case management, and connections to community-based services.
3. Provide counseling, peer-support, recovery case management and residential treatment with access to medications for those who need it to persons with OUD and any co-occurring SUD/MH conditions.

4. Provide access to housing for people with OUD and any co-occurring SUD/MH conditions, including supportive housing, recovery housing, housing assistance programs, training for housing providers, or recovery housing programs that allow or integrate FDA-approved mediation with other support services.
5. Provide community support services, including social and legal services, to assist in deinstitutionalizing persons with OUD and any co-occurring SUD/MH conditions.
6. Support or expand peer-recovery centers, which may include support groups, social events, computer access, or other services for persons with OUD and any cooccurring SUD/MH conditions.
7. Provide or support transportation to treatment or recovery programs or services for persons with OUD and any co-occurring SUD/MH conditions.
8. Provide employment training or educational services for persons in treatment for or recovery from OUD and any co-occurring SUD/MH conditions.
9. Identify successful recovery programs such as physician, pilot, and college recovery programs, and provide support and technical assistance to increase the number and capacity of high-quality programs to help those in recovery.
10. Engage non-profits, faith-based communities, and community coalitions to support people in treatment and recovery and to support family members in their efforts to support the person with OUD in the family.
11. Provide training and development of procedures for government staff to appropriately interact and provide social and other services to individuals with or in recovery from OUD, including reducing stigma.
12. Support stigma reduction efforts regarding treatment and support for persons with OUD, including reducing the stigma on effective treatment.
13. Create or support culturally appropriate services and programs for persons with OUD and any co-occurring SUD/MH conditions, including new Americans.
14. Create and/or support recovery high schools.
15. Hire or train behavioral health workers to provide or expand any of the services or supports listed above.

**C. CONNECT PEOPLE WHO NEED HELP TO THE HELP THEY NEED  
(CONNECTIONS TO CARE)**

Provide connections to care for people who have—or are at risk of developing—OUD and any co-occurring SUD/MH conditions through evidence-based or evidence-informed programs or strategies that may include, but are not limited to, those that:



1. Ensure that health care providers are screening for OUD and other risk factors and know how to appropriately counsel and treat (or refer if necessary) a patient for OUD treatment.
2. Fund SBIRT programs to reduce the transition from use to disorders, including SBIRT services to pregnant women who are uninsured or not eligible for Medicaid.
3. Provide training and long-term implementation of SBIRT in key systems (health, schools, colleges, criminal justice, and probation), with a focus on youth and young adults when transition from misuse to opioid disorder is common.
4. Purchase automated versions of SBIRT and support ongoing costs of the technology.
5. Expand services such as navigators and on-call teams to begin MAT in hospital emergency departments.
6. Provide training for emergency room personnel treating opioid overdose patients on post-discharge planning, including community referrals for MAT, recovery case management or support services.
7. Support hospital programs that transition persons with OUD and any co-occurring SUD/MH conditions, or persons who have experienced an opioid overdose, into clinically appropriate follow-up care through a bridge clinic or similar approach.
8. Support crisis stabilization centers that serve as an alternative to hospital emergency departments for persons with OUD and any co-occurring SUD/MH conditions or persons that have experienced an opioid overdose.
9. Support the work of Emergency Medical Systems, including peer support specialists, to connect individuals to treatment or other appropriate services following an opioid overdose or other opioid-related adverse event.
10. Provide funding for peer support specialists or recovery coaches in emergency departments, detox facilities, recovery centers, recovery housing, or similar settings; offer services, supports, or connections to care to persons with OUD and any co-occurring SUD/MH conditions or to persons who have experienced an opioid overdose.
11. Expand warm hand-off services to transition to recovery services.
12. Create or support school-based contacts that parents can engage with to seek immediate treatment services for their child; and support prevention, intervention, treatment, and recovery programs focused on young people.
13. Develop and support best practices on addressing OUD in the workplace.

14. Support assistance programs for health care providers with OUD.
15. Engage non-profits and the faith community as a system to support outreach for treatment.
16. Support centralized call centers that provide information and connections to appropriate services and supports for persons with OUD and any co-occurring SUD/MH conditions.

**D. ADDRESS THE NEEDS OF CRIMINAL JUSTICE-INVOLVED PERSONS**

Address the needs of persons with OUD and any co-occurring SUD/MH conditions who are involved in, are at risk of becoming involved in, or are transitioning out of the criminal justice system through evidence-based or evidence-informed programs or strategies that may include, but are not limited to, those that:

1. Support pre-arrest or pre-arraignment diversion and deflection strategies for persons with OUD and any co-occurring SUD/MH conditions, including established strategies such as:
  1. Self-referral strategies such as the Angel Programs or the Police Assisted Addiction Recovery Initiative (“*PAARI*”);
  2. Active outreach strategies such as the Drug Abuse Response Team (“*DART*”) model;
  3. “Naloxone Plus” strategies, which work to ensure that individuals who have received naloxone to reverse the effects of an overdose are then linked to treatment programs or other appropriate services;
  4. Officer prevention strategies, such as the Law Enforcement Assisted Diversion (“*LEAD*”) model;
  5. Officer intervention strategies such as the Leon County, Florida Adult Civil Citation Network or the Chicago Westside Narcotics Diversion to Treatment Initiative; or
  6. Co-responder and/or alternative responder models to address OUD-related 911 calls with greater SUD expertise.
2. Support pre-trial services that connect individuals with OUD and any co-occurring SUD/MH conditions to evidence-informed treatment, including MAT, and related services.
3. Support treatment and recovery courts that provide evidence-based options for persons with OUD and any co-occurring SUD/MH conditions.

4. Provide evidence-informed treatment, including MAT, recovery support, harm reduction, or other appropriate services to individuals with OUD and any cooccurring SUD/MH conditions who are incarcerated in jail or prison.
5. Provide evidence-informed treatment, including MAT, recovery support, harm reduction, or other appropriate services to individuals with OUD and any cooccurring SUD/MH conditions who are leaving jail or prison or have recently left jail or prison, are on probation or parole, are under community corrections supervision, or are in re-entry programs or facilities.
6. Support critical time interventions (“*CTI*”), particularly for individuals living with dual-diagnosis OUD/serious mental illness, and services for individuals who face immediate risks and service needs and risks upon release from correctional settings.
7. Provide training on best practices for addressing the needs of criminal justice-involved persons with OUD and any co-occurring SUD/MH conditions to law enforcement, correctional, or judicial personnel or to providers of treatment, recovery, harm reduction, case management, or other services offered in connection with any of the strategies described in this section.

**E. ADDRESS THE NEEDS OF PREGNANT OR PARENTING WOMEN AND THEIR FAMILIES, INCLUDING BABIES WITH NEONATAL ABSTINENCE SYNDROME**

Address the needs of pregnant or parenting women with OUD and any co-occurring SUD/MH conditions, and the needs of their families, including babies with neonatal abstinence syndrome (“*NAS*”), through evidence-based or evidence-informed programs or strategies that may include, but are not limited to, those that:

1. Support evidence-based or evidence-informed treatment, including MAT, recovery services and supports, and prevention services for pregnant women—or women who could become pregnant—who have OUD and any co-occurring SUD/MH conditions, and other measures to educate and provide support to families affected by Neonatal Abstinence Syndrome.
2. Expand comprehensive evidence-based treatment and recovery services, including MAT, for uninsured women with OUD and any co-occurring SUD/MH conditions for up to 12 months postpartum.
3. Provide training for obstetricians or other healthcare personnel who work with pregnant women and their families regarding treatment of OUD and any co-occurring SUD/MH conditions.
4. Expand comprehensive evidence-based treatment and recovery support for *NAS* babies; expand services for better continuum of care with infant-need dyad; and expand long-term treatment and services for medical monitoring of *NAS* babies and their families.

5. Provide training to health care providers who work with pregnant or parenting women on best practices for compliance with federal requirements that children born with NAS get referred to appropriate services and receive a plan of safe care.
6. Provide child and family supports for parenting women with OUD and any cooccurring SUD/MH conditions.
7. Provide enhanced family support and child care services for parents with OUD and any co-occurring SUD/MH conditions.
8. Provide enhanced support for children and family members suffering trauma as a result of addiction in the family; and offer trauma-informed behavioral health treatment for adverse childhood events.
9. Offer home-based wrap-around services to persons with OUD and any co-occurring SUD/MH conditions, including, but not limited to, parent skills training.
10. Provide support for Children’s Services—Fund additional positions and services, including supportive housing and other residential services, relating to children being removed from the home and/or placed in foster care due to custodial opioid use.

<b>PART TWO: PREVENTION</b>
-----------------------------

**F. PREVENT OVER-PRESCRIBING AND ENSURE APPROPRIATE PRESCRIBING AND DISPENSING OF OPIOIDS**

Support efforts to prevent over-prescribing and ensure appropriate prescribing and dispensing of opioids through evidence-based or evidence-informed programs or strategies that may include, but are not limited to, the following:

1. Funding medical provider education and outreach regarding best prescribing practices for opioids consistent with the Guidelines for Prescribing Opioids for Chronic Pain from the U.S. Centers for Disease Control and Prevention, including providers at hospitals (academic detailing).
2. Training for health care providers regarding safe and responsible opioid prescribing, dosing, and tapering patients off opioids.
3. Continuing Medical Education (CME) on appropriate prescribing of opioids.
4. Providing Support for non-opioid pain treatment alternatives, including training providers to offer or refer to multi-modal, evidence-informed treatment of pain.
5. Supporting enhancements or improvements to Prescription Drug Monitoring Programs (“*PDMPs*”), including, but not limited to, improvements that:

1. Increase the number of prescribers using PDMPs;
2. Improve point-of-care decision-making by increasing the quantity, quality, or format of data available to prescribers using PDMPs, by improving the interface that prescribers use to access PDMP data, or both; or
3. Enable states to use PDMP data in support of surveillance or intervention strategies, including MAT referrals and follow-up for individuals identified within PDMP data as likely to experience OUD in a manner that complies with all relevant privacy and security laws and rules.
6. Ensuring PDMPs incorporate available overdose/naloxone deployment data, including the United States Department of Transportation’s Emergency Medical Technician overdose database in a manner that complies with all relevant privacy and security laws and rules.
7. Increasing electronic prescribing to prevent diversion or forgery.
8. Educating dispensers on appropriate opioid dispensing.

**G. PREVENT MISUSE OF OPIOIDS**

Support efforts to discourage or prevent misuse of opioids through evidence-based or evidence-informed programs or strategies that may include, but are not limited to, the following:

1. Funding media campaigns to prevent opioid misuse.
2. Corrective advertising or affirmative public education campaigns based on evidence.
3. Public education relating to drug disposal.
4. Drug take-back disposal or destruction programs.
5. Funding community anti-drug coalitions that engage in drug prevention efforts.
6. Supporting community coalitions in implementing evidence-informed prevention, such as reduced social access and physical access, stigma reduction—including staffing, educational campaigns, support for people in treatment or recovery, or training of coalitions in evidence-informed implementation, including the Strategic Prevention Framework developed by the U.S. Substance Abuse and Mental Health Services Administration (“SAMHSA”).
7. Engaging non-profits and faith-based communities as systems to support prevention.

8. Funding evidence-based prevention programs in schools or evidence-informed school and community education programs and campaigns for students, families, school employees, school athletic programs, parent-teacher and student associations, and others.
9. School-based or youth-focused programs or strategies that have demonstrated effectiveness in preventing drug misuse and seem likely to be effective in preventing the uptake and use of opioids.
10. Create or support community-based education or intervention services for families, youth, and adolescents at risk for OUD and any co-occurring SUD/MH conditions.
11. Support evidence-informed programs or curricula to address mental health needs of young people who may be at risk of misusing opioids or other drugs, including emotional modulation and resilience skills.
12. Support greater access to mental health services and supports for young people, including services and supports provided by school nurses, behavioral health workers or other school staff, to address mental health needs in young people that (when not properly addressed) increase the risk of opioid or another drug misuse.

**H. PREVENT OVERDOSE DEATHS AND OTHER HARMS (HARM REDUCTION)**

Support efforts to prevent or reduce overdose deaths or other opioid-related harms through evidence-based or evidence-informed programs or strategies that may include, but are not limited to, the following:

1. Increased availability and distribution of naloxone and other drugs that treat overdoses for first responders, overdose patients, individuals with OUD and their friends and family members, schools, community navigators and outreach workers, persons being released from jail or prison, or other members of the general public.
2. Public health entities providing free naloxone to anyone in the community.
3. Training and education regarding naloxone and other drugs that treat overdoses for first responders, overdose patients, patients taking opioids, families, schools, community support groups, and other members of the general public.
4. Enabling school nurses and other school staff to respond to opioid overdoses, and provide them with naloxone, training, and support.
5. Expanding, improving, or developing data tracking software and applications for overdoses/naloxone revivals.
6. Public education relating to emergency responses to overdoses.

7. Public education relating to immunity and Good Samaritan laws.
8. Educating first responders regarding the existence and operation of immunity and Good Samaritan laws.
9. Syringe service programs and other evidence-informed programs to reduce harms associated with intravenous drug use, including supplies, staffing, space, peer support services, referrals to treatment, fentanyl checking, connections to care, and the full range of harm reduction and treatment services provided by these programs.
10. Expanding access to testing and treatment for infectious diseases such as HIV and Hepatitis C resulting from intravenous opioid use.
11. Supporting mobile units that offer or provide referrals to harm reduction services, treatment, recovery supports, health care, or other appropriate services to persons that use opioids or persons with OUD and any co-occurring SUD/MH conditions.
12. Providing training in harm reduction strategies to health care providers, students, peer recovery coaches, recovery outreach specialists, or other professionals that provide care to persons who use opioids or persons with OUD and any co-occurring SUD/MH conditions.
13. Supporting screening for fentanyl in routine clinical toxicology testing.

<b>PART THREE: OTHER STRATEGIES</b>
-------------------------------------

**I. FIRST RESPONDERS**

In addition to items in section C, D and H relating to first responders, support the following:

1. Education of law enforcement or other first responders regarding appropriate practices and precautions when dealing with fentanyl or other drugs.
2. Provision of wellness and support services for first responders and others who experience secondary trauma associated with opioid-related emergency events.

**J. LEADERSHIP, PLANNING AND COORDINATION**

Support efforts to provide leadership, planning, coordination, facilitations, training and technical assistance to abate the opioid epidemic through activities, programs, or strategies that may include, but are not limited to, the following:

1. Statewide, regional, local or community regional planning to identify root causes of addiction and overdose, goals for reducing harms related to the opioid epidemic, and areas and populations with the greatest needs for treatment intervention services, and to support training and technical assistance and other

strategies to abate the opioid epidemic described in this opioid abatement strategy list.

2. A dashboard to (a) share reports, recommendations, or plans to spend opioid settlement funds; (b) to show how opioid settlement funds have been spent; (c) to report program or strategy outcomes; or (d) to track, share or visualize key opioid- or health-related indicators and supports as identified through collaborative statewide, regional, local or community processes.
3. Invest in infrastructure or staffing at government or not-for-profit agencies to support collaborative, cross-system coordination with the purpose of preventing overprescribing, opioid misuse, or opioid overdoses, treating those with OUD and any co-occurring SUD/MH conditions, supporting them in treatment or recovery, connecting them to care, or implementing other strategies to abate the opioid epidemic described in this opioid abatement strategy list.
4. Provide resources to staff government oversight and management of opioid abatement programs.

#### **K. TRAINING**

In addition to the training referred to throughout this document, support training to abate the opioid epidemic through activities, programs, or strategies that may include, but are not limited to, those that:

1. Provide funding for staff training or networking programs and services to improve the capability of government, community, and not-for-profit entities to abate the opioid crisis.
2. Support infrastructure and staffing for collaborative cross-system coordination to prevent opioid misuse, prevent overdoses, and treat those with OUD and any cooccurring SUD/MH conditions, or implement other strategies to abate the opioid epidemic described in this opioid abatement strategy list (*e.g.*, health care, primary care, pharmacies, PDMPs, etc.).

#### **L. RESEARCH**

Support opioid abatement research that may include, but is not limited to, the following:

1. Monitoring, surveillance, data collection and evaluation of programs and strategies described in this opioid abatement strategy list.
2. Research non-opioid treatment of chronic pain.
3. Research on improved service delivery for modalities such as SBIRT that demonstrate promising but mixed results in populations vulnerable to opioid use disorders.



4. Research on novel harm reduction and prevention efforts such as the provision of fentanyl test strips.
5. Research on innovative supply-side enforcement efforts such as improved detection of mail-based delivery of synthetic opioids.
6. Expanded research on swift/certain/fair models to reduce and deter opioid misuse within criminal justice populations that build upon promising approaches used to address other substances (*e.g.*, Hawaii HOPE and Dakota 24/7).
7. Epidemiological surveillance of OUD-related behaviors in critical populations, including individuals entering the criminal justice system, including, but not limited to approaches modeled on the Arrestee Drug Abuse Monitoring (“ADAM”) system.
8. Qualitative and quantitative research regarding public health risks and harm reduction opportunities within illicit drug markets, including surveys of market participants who sell or distribute illicit opioids.
9. Geospatial analysis of access barriers to MAT and their association with treatment engagement and treatment outcomes.

**EXHIBIT F**

**List of States and Overall Allocation Percentages**

<b>Alaska</b>	0.2557955294%
<b>American Samoa</b>	0.0191834392%
<b>Arizona</b>	2.6615833823%
<b>Arkansas</b>	1.0444409688%
<b>California</b>	11.1157787586%
<b>Colorado</b>	1.8616660165%
<b>Connecticut</b>	1.4495669159%
<b>Delaware</b>	0.4952425518%
<b>District of Columbia</b>	0.2016442528%
<b>Georgia</b>	3.1238692398%
<b>Guam</b>	0.0538195977%
<b>Hawaii</b>	0.3637319771%
<b>Idaho</b>	0.5511268529%
<b>Illinois</b>	3.7267807228%
<b>Indiana</b>	2.4837762383%
<b>Iowa</b>	0.8312430751%
<b>Kansas</b>	0.8784715219%
<b>Kentucky</b>	2.2366652249%
<b>Louisiana</b>	1.6414669014%
<b>Maine</b>	0.5930462294%
<b>Maryland</b>	2.3646968446%
<b>Massachusetts</b>	2.5808944372%
<b>Michigan</b>	3.8115795226%
<b>Minnesota</b>	1.4534316941%
<b>Mississippi</b>	0.9662576251%
<b>Missouri</b>	2.2470994124%
<b>Montana</b>	0.3501746091%
<b>N. Mariana Islands</b>	0.0187170792%
<b>Nebraska</b>	0.4673742159%
<b>Nevada</b>	1.3464414888%
<b>New Hampshire</b>	0.6481247935%
<b>New Jersey</b>	3.0868152098%
<b>New York</b>	5.7834378670%
<b>North Carolina</b>	3.6415375306%
<b>North Dakota</b>	0.1904938536%
<b>Ohio</b>	4.8372585804%

<b>Oklahoma</b>	1.7166904525%
<b>Oregon</b>	1.5395677885%
<b>Pennsylvania</b>	5.1406020829%
<b>Puerto Rico</b>	0.7956080574%
<b>Rhode Island</b>	0.5003004364%
<b>South Carolina</b>	1.7246195407%
<b>South Dakota</b>	0.2220685158%
<b>Tennessee</b>	3.0117628404%
<b>Texas</b>	7.0508308295%
<b>Utah</b>	1.2847240804%
<b>Vermont</b>	0.2851259773%
<b>Virgin Islands</b>	0.0353676254%
<b>Virginia</b>	2.5546090245%
<b>Washington</b>	2.5980676129%
<b>Wisconsin</b>	1.9699254815%
<b>Wyoming</b>	0.1868954934%

## EXHIBIT G

### Subdivisions Eligible to Receive Direct Allocations from the Subdivision Fund and Subdivision Fund Allocation Percentages

The Subdivisions set forth on this Exhibit G are eligible to receive direct allocations from the Subdivision Fund, if such Subdivisions are otherwise eligible to receive such funds under this Agreement. By default, the Subdivisions set forth on this Exhibit G shall include all Subdivisions set forth on Exhibit G of the national opioid settlement agreement dated July 21, 2021 with Janssen Pharmaceuticals, Inc., et al., including all amendments up to the State Participation Date of this Agreement. A State may elect to add any additional Subdivisions to this Exhibit G at any time prior to the Threshold Subdivision Participation Date.

Immediately upon the effectiveness of any State-Subdivision Agreement, Allocation Statute, Statutory Trust, or voluntary redistribution allowed by subsection V.D.3 (or upon the effectiveness of an amendment to any State-Subdivision Agreement, Allocation Statute, Statutory Trust, or voluntary redistribution allowed by subsection V.D.3) that addresses allocation from the Subdivision Fund, whether before or after the Threshold Subdivision Participation Date, this Exhibit G will automatically be amended to reflect the allocation from the Subdivision Fund pursuant to the State-Subdivision Agreement, Allocation Statute, Statutory Trust, or voluntary redistribution allowed by subsection V.D.3.

For the avoidance of doubt, inclusion on this Exhibit G shall not create any claim for any amount of the Settlement Fund, and no such amounts shall be allocated or distributed to any Subdivision included herein if such Subdivision does not otherwise meet all requirements to receive any such funds pursuant to the Agreement.

[List to be Added]

**EXHIBIT H**

**[Intentionally Omitted]**

## EXHIBIT I

### Primary Subdivisions

- |     |                                  |     |                                |
|-----|----------------------------------|-----|--------------------------------|
| 1.  | Alabaster, City of, Alabama      | 44. | Etowah, County of, Alabama     |
| 2.  | Albertville, City of, Alabama    | 45. | Eufaula, City of, Alabama      |
| 3.  | Alexander City, City of, Alabama | 46. | Fairfield, City of, Alabama    |
| 4.  | Anniston, City of, Alabama       | 47. | Fairhope, City of, Alabama     |
| 5.  | Athens, City of, Alabama         | 48. | Fayette, County of, Alabama    |
| 6.  | Auburn, City of, Alabama         | 49. | Florence, City of, Alabama     |
| 7.  | Autauga, County of, Alabama      | 50. | Foley, City of, Alabama        |
| 8.  | Baldwin, County of, Alabama      | 51. | Fort Payne, City of, Alabama   |
| 9.  | Barbour, County of, Alabama      | 52. | Franklin, County of, Alabama   |
| 10. | Bessemer, City of, Alabama       | 53. | Gadsden, City of, Alabama      |
| 11. | Bibb, County of, Alabama         | 54. | Gardendale, City of, Alabama   |
| 12. | Birmingham, City of, Alabama     | 55. | Geneva, County of, Alabama     |
| 13. | Blount, County of, Alabama       | 56. | Gulf Shores, City of, Alabama  |
| 14. | Bullock, County of, Alabama      | 57. | Hale, County of, Alabama       |
| 15. | Butler, County of, Alabama       | 58. | Hartselle, City of, Alabama    |
| 16. | Calera, City of, Alabama         | 59. | Helena, City of, Alabama       |
| 17. | Calhoun, County of, Alabama      | 60. | Henry, County of, Alabama      |
| 18. | Center Point, City of, Alabama   | 61. | Homewood, City of, Alabama     |
| 19. | Chambers, County of, Alabama     | 62. | Hoover, City of, Alabama       |
| 20. | Chelsea, City of, Alabama        | 63. | Houston, County of, Alabama    |
| 21. | Cherokee, County of, Alabama     | 64. | Hueytown, City of, Alabama     |
| 22. | Chilton, County of, Alabama      | 65. | Huntsville, City of, Alabama   |
| 23. | Choctaw, County of, Alabama      | 66. | Irondale, City of, Alabama     |
| 24. | Clarke, County of, Alabama       | 67. | Jackson, County of, Alabama    |
| 25. | Clay, County of, Alabama         | 68. | Jacksonville, City of, Alabama |
| 26. | Cleburne, County of, Alabama     | 69. | Jasper, City of, Alabama       |
| 27. | Coffee, County of, Alabama       | 70. | Jefferson, County of, Alabama  |
| 28. | Colbert, County of, Alabama      | 71. | Lamar, County of, Alabama      |
| 29. | Conecuh, County of, Alabama      | 72. | Lauderdale, County of, Alabama |
| 30. | Coosa, County of, Alabama        | 73. | Lawrence, County of, Alabama   |
| 31. | Covington, County of, Alabama    | 74. | Lee, County of, Alabama        |
| 32. | Crenshaw, County of, Alabama     | 75. | Leeds, City of, Alabama        |
| 33. | Cullman, City of, Alabama        | 76. | Limestone, County of, Alabama  |
| 34. | Cullman, County of, Alabama      | 77. | Macon, County of, Alabama      |
| 35. | Dale, County of, Alabama         | 78. | Madison, City of, Alabama      |
| 36. | Dallas, County of, Alabama       | 79. | Madison, County of, Alabama    |
| 37. | Daphne, City of, Alabama         | 80. | Marengo, County of, Alabama    |
| 38. | Decatur, City of, Alabama        | 81. | Marion, County of, Alabama     |
| 39. | DeKalb, County of, Alabama       | 82. | Marshall, County of, Alabama   |
| 40. | Dothan, City of, Alabama         | 83. | Millbrook, City of, Alabama    |
| 41. | Elmore, County of, Alabama       | 84. | Mobile, City of, Alabama       |
| 42. | Enterprise, City of, Alabama     | 85. | Mobile, County of, Alabama     |
| 43. | Escambia, County of, Alabama     | 86. | Monroe, County of, Alabama     |

87. Montgomery, City of, Alabama
88. Montgomery, County of, Alabama
89. Moody, City of, Alabama
90. Morgan, County of, Alabama
91. Mountain Brook, City of, Alabama
92. Muscle Shoals, City of, Alabama
93. Northport, City of, Alabama
94. Opelika, City of, Alabama
95. Oxford, City of, Alabama
96. Ozark, City of, Alabama
97. Pelham, City of, Alabama
98. Pell City, City of, Alabama
99. Phenix City, City of, Alabama
100. Pickens, County of, Alabama
101. Pike, County of, Alabama
102. Pike Road, Town of, Alabama
103. Prattville, City of, Alabama
104. Prichard, City of, Alabama
105. Randolph, County of, Alabama
106. Russell, County of, Alabama
107. Saraland, City of, Alabama
108. Scottsboro, City of, Alabama
109. Selma, City of, Alabama
110. Shelby, County of, Alabama
111. St. Clair, County of, Alabama
112. Sumter, County of, Alabama
113. Sylacauga, City of, Alabama
114. Talladega, City of, Alabama
115. Talladega, County of, Alabama
116. Tallapoosa, County of, Alabama
117. Troy, City of, Alabama
118. Trussville, City of, Alabama
119. Tuscaloosa, City of, Alabama
120. Tuscaloosa, County of, Alabama
121. Vestavia Hills, City of, Alabama
122. Walker, County of, Alabama
123. Washington, County of, Alabama
124. Wilcox, County of, Alabama
125. Winston, County of, Alabama
126. Anchorage, Municipality of, Alaska
127. Fairbanks, City of, Alaska
128. Fairbanks North Star, Borough of, Alaska
129. Juneau, City of/ Borough of, Alaska
130. Kenai Peninsula, Borough of, Alaska
131. Ketchikan Gateway, Borough of, Alaska
132. Kodiak Island, Borough of, Alaska
133. Matanuska-Susitna, Borough of, Alaska
134. Wasilla, City of, Alaska
135. Apache, County of, Arizona
136. Apache Junction, City of, Arizona
137. Avondale, City of, Arizona
138. Buckeye, City of, Arizona
139. Bullhead City, City of, Arizona
140. Camp Verde, Town of, Arizona
141. Casa Grande, City of, Arizona
142. Chandler, City of, Arizona
143. Chino Valley, Town of, Arizona
144. Cochise, County of, Arizona
145. Coconino, County of, Arizona
146. Coolidge, City of, Arizona
147. Cottonwood, City of, Arizona
148. Douglas, City of, Arizona
149. El Mirage, City of, Arizona
150. Eloy, City of, Arizona
151. Flagstaff, City of, Arizona
152. Florence, Town of, Arizona
153. Fountain Hills, Town of, Arizona
154. Gila, County of, Arizona
155. Gilbert, Town of, Arizona
156. Glendale, City of, Arizona
157. Goodyear, City of, Arizona
158. Graham, County of, Arizona
159. Kingman, City of, Arizona
160. La Paz, County of, Arizona
161. Lake Havasu City, City of, Arizona
162. Marana, Town of, Arizona
163. Maricopa, City of, Arizona
164. Maricopa, County of, Arizona
165. Mesa, City of, Arizona
166. Mohave, County of, Arizona
167. Navajo, County of, Arizona
168. Nogales, City of, Arizona
169. Oro Valley, Town of, Arizona
170. Paradise Valley, Town of, Arizona
171. Payson, Town of, Arizona
172. Peoria, City of, Arizona
173. Phoenix, City of, Arizona
174. Pima, County of, Arizona

- 175. Pinal, County of, Arizona
- 176. Prescott, City of, Arizona
- 177. Prescott Valley, Town of, Arizona
- 178. Queen Creek, Town of, Arizona
- 179. Sahuarita, Town of, Arizona
- 180. San Luis, City of, Arizona
- 181. Santa Cruz, County of, Arizona
- 182. Scottsdale, City of, Arizona
- 183. Sedona, City of, Arizona
- 184. Show Low, City of, Arizona
- 185. Sierra Vista, City of, Arizona
- 186. Somerton, City of, Arizona
- 187. Surprise, City of, Arizona
- 188. Tempe, City of, Arizona
- 189. Tucson, City of, Arizona
- 190. Yavapai, County of, Arizona
- 191. Yuma, City of, Arizona
- 192. Yuma, County of, Arizona
- 193. Arkadelphia, City of, Arkansas
- 194. Arkansas, County of, Arkansas
- 195. Ashley, County of, Arkansas
- 196. Batesville, City of, Arkansas
- 197. Baxter, County of, Arkansas
- 198. Bella Vista, City of, Arkansas
- 199. Benton, City of, Arkansas
- 200. Benton, County of, Arkansas
- 201. Bentonville, City of, Arkansas
- 202. Blytheville, City of, Arkansas
- 203. Boone, County of, Arkansas
- 204. Bradley, County of, Arkansas
- 205. Bryant, City of, Arkansas
- 206. Cabot, City of, Arkansas
- 207. Camden, City of, Arkansas
- 208. Carroll, County of, Arkansas
- 209. Centerton, City of, Arkansas
- 210. Chicot, County of, Arkansas
- 211. Clark, County of, Arkansas
- 212. Clay, County of, Arkansas
- 213. Cleburne, County of, Arkansas
- 214. Columbia, County of, Arkansas
- 215. Conway, City of, Arkansas
- 216. Conway, County of, Arkansas
- 217. Craighead, County of, Arkansas
- 218. Crawford, County of, Arkansas
- 219. Crittenden, County of, Arkansas
- 220. Cross, County of, Arkansas
- 221. Desha, County of, Arkansas
- 222. Drew, County of, Arkansas
- 223. El Dorado, City of, Arkansas
- 224. Faulkner, County of, Arkansas
- 225. Fayetteville, City of, Arkansas
- 226. Forrest City, City of, Arkansas
- 227. Fort Smith, City of, Arkansas
- 228. Franklin, County of, Arkansas
- 229. Fulton, County of, Arkansas
- 230. Garland, County of, Arkansas
- 231. Grant, County of, Arkansas
- 232. Greene, County of, Arkansas
- 233. Harrison, City of, Arkansas
- 234. Helena-West Helena, City of, Arkansas
- 235. Hempstead, County of, Arkansas
- 236. Hot Spring, County of, Arkansas
- 237. Hot Springs, City of, Arkansas
- 238. Howard, County of, Arkansas
- 239. Independence, County of, Arkansas
- 240. IZard, County of, Arkansas
- 241. Jackson, County of, Arkansas
- 242. Jacksonville, City of, Arkansas
- 243. Jefferson, County of, Arkansas
- 244. Johnson, County of, Arkansas
- 245. Jonesboro, City of, Arkansas
- 246. Lawrence, County of, Arkansas
- 247. Lincoln, County of, Arkansas
- 248. Little River, County of, Arkansas
- 249. Little Rock, City of, Arkansas
- 250. Logan, County of, Arkansas
- 251. Lonoke, County of, Arkansas
- 252. Madison, County of, Arkansas
- 253. Magnolia, City of, Arkansas
- 254. Malvern, City of, Arkansas
- 255. Marion, City of, Arkansas
- 256. Marion, County of, Arkansas
- 257. Maumelle, City of, Arkansas
- 258. Miller, County of, Arkansas
- 259. Mississippi, County of, Arkansas
- 260. Mountain Home, City of, Arkansas
- 261. North Little Rock, City of, Arkansas
- 262. Ouachita, County of, Arkansas
- 263. Paragould, City of, Arkansas
- 264. Perry, County of, Arkansas
- 265. Phillips, County of, Arkansas



- 266. Pike, County of, Arkansas
- 267. Pine Bluff, City of, Arkansas
- 268. Poinsett, County of, Arkansas
- 269. Polk, County of, Arkansas
- 270. Pope, County of, Arkansas
- 271. Pulaski, County of, Arkansas
- 272. Randolph, County of, Arkansas
- 273. Rogers, City of, Arkansas
- 274. Russellville, City of, Arkansas
- 275. Saline, County of, Arkansas
- 276. Scott, County of, Arkansas
- 277. Searcy, City of, Arkansas
- 278. Sebastian, County of, Arkansas
- 279. Sevier, County of, Arkansas
- 280. Sharp, County of, Arkansas
- 281. Sherwood, City of, Arkansas
- 282. Siloam Springs, City of, Arkansas
- 283. Springdale, City of, Arkansas
- 284. St. Francis, County of, Arkansas
- 285. Stone, County of, Arkansas
- 286. Texarkana, City of, Arkansas
- 287. Union, County of, Arkansas
- 288. Van Buren, City of, Arkansas
- 289. Van Buren, County of, Arkansas
- 290. Washington, County of, Arkansas
- 291. West Memphis, City of, Arkansas
- 292. White, County of, Arkansas
- 293. Yell, County of, Arkansas
- 294. Adelanto, City of, California
- 295. Agoura Hills, City of, California
- 296. Alameda, City of, California
- 297. Alameda, County of, California
- 298. Albany, City of, California
- 299. Alhambra, City of, California
- 300. Aliso Viejo, City of, California
- 301. Amador, County of, California
- 302. American Canyon, City of, California
- 303. Anaheim, City of, California
- 304. Anderson, City of, California
- 305. Antioch, City of, California
- 306. Apple Valley, Town of, California
- 307. Arcadia, City of, California
- 308. Arcata, City of, California
- 309. Arroyo Grande, City of, California
- 310. Artesia, City of, California
- 311. Arvin, City of, California
- 312. Atascadero, City of, California
- 313. Atwater, City of, California
- 314. Auburn, City of, California
- 315. Avenal, City of, California
- 316. Azusa, City of, California
- 317. Bakersfield, City of, California
- 318. Baldwin Park, City of, California
- 319. Banning, City of, California
- 320. Barstow, City of, California
- 321. Beaumont, City of, California
- 322. Bell, City of, California
- 323. Bell Gardens, City of, California
- 324. Bellflower, City of, California
- 325. Belmont, City of, California
- 326. Benicia, City of, California
- 327. Berkeley, City of, California
- 328. Beverly Hills, City of, California
- 329. Blythe, City of, California
- 330. Brawley, City of, California
- 331. Brea, City of, California
- 332. Brentwood, City of, California
- 333. Buena Park, City of, California
- 334. Burbank, City of, California
- 335. Burlingame, City of, California
- 336. Butte, County of, California
- 337. Calabasas, City of, California
- 338. Calaveras, County of, California
- 339. Calexico, City of, California
- 340. California City, City of, California
- 341. Camarillo, City of, California
- 342. Campbell, City of, California
- 343. Canyon Lake, City of, California
- 344. Capitola, City of, California
- 345. Carlsbad, City of, California
- 346. Carpinteria, City of, California
- 347. Carson, City of, California
- 348. Cathedral City, City of, California
- 349. Ceres, City of, California
- 350. Cerritos, City of, California
- 351. Chico, City of, California
- 352. Chino, City of, California
- 353. Chino Hills, City of, California
- 354. Chowchilla, City of, California
- 355. Chula Vista, City of, California
- 356. Citrus Heights, City of, California

- 357. Claremont, City of, California
- 358. Clayton, City of, California
- 359. Clearlake, City of, California
- 360. Clovis, City of, California
- 361. Coachella, City of, California
- 362. Coalinga, City of, California
- 363. Colton, City of, California
- 364. Colusa, County of, California
- 365. Commerce, City of, California
- 366. Compton, City of, California
- 367. Concord, City of, California
- 368. Contra Costa, County of, California
- 369. Corcoran, City of, California
- 370. Corona, City of, California
- 371. Coronado, City of, California
- 372. Costa Mesa, City of, California
- 373. Covina, City of, California
- 374. Cudahy, City of, California
- 375. Culver City, City of, California
- 376. Cupertino, City of, California
- 377. Cypress, City of, California
- 378. Daly City, City of, California
- 379. Dana Point, City of, California
- 380. Danville, Town of, California
- 381. Davis, City of, California
- 382. Del Norte, County of, California
- 383. Delano, City of, California
- 384. Desert Hot Springs, City of,  
California
- 385. Diamond Bar, City of, California
- 386. Dinuba, City of, California
- 387. Dixon, City of, California
- 388. Downey, City of, California
- 389. Duarte, City of, California
- 390. Dublin, City of, California
- 391. East Palo Alto, City of, California
- 392. Eastvale, City of, California
- 393. El Cajon, City of, California
- 394. El Centro, City of, California
- 395. El Cerrito, City of, California
- 396. El Dorado, County of, California
- 397. El Monte, City of, California
- 398. El Paso de Robles (Paso Robles),  
City of, California
- 399. El Segundo, City of, California
- 400. Elk Grove, City of, California
- 401. Emeryville, City of, California
- 402. Encinitas, City of, California
- 403. Escondido, City of, California
- 404. Eureka, City of, California
- 405. Exeter, City of, California
- 406. Fairfield, City of, California
- 407. Farmersville, City of, California
- 408. Fillmore, City of, California
- 409. Folsom, City of, California
- 410. Fontana, City of, California
- 411. Fortuna, City of, California
- 412. Foster City, City of, California
- 413. Fountain Valley, City of, California
- 414. Fremont, City of, California
- 415. Fresno, City of, California
- 416. Fresno, County of, California
- 417. Fullerton, City of, California
- 418. Galt, City of, California
- 419. Garden Grove, City of, California
- 420. Gardena, City of, California
- 421. Gilroy, City of, California
- 422. Glendale, City of, California
- 423. Glendora, City of, California
- 424. Glenn, County of, California
- 425. Goleta, City of, California
- 426. Grand Terrace, City of, California
- 427. Grass Valley, City of, California
- 428. Greenfield, City of, California
- 429. Grover Beach, City of, California
- 430. Half Moon Bay, City of, California
- 431. Hanford, City of, California
- 432. Hawaiian Gardens, City of,  
California
- 433. Hawthorne, City of, California
- 434. Hayward, City of, California
- 435. Healdsburg, City of, California
- 436. Hemet, City of, California
- 437. Hercules, City of, California
- 438. Hermosa Beach, City of, California
- 439. Hesperia, City of, California
- 440. Highland, City of, California
- 441. Hillsborough, Town of, California
- 442. Hollister, City of, California
- 443. Humboldt, County of, California
- 444. Huntington Beach, City of,  
California

- 445. Huntington Park, City of, California
- 446. Imperial Beach, City of, California
- 447. Imperial, City of, California
- 448. Imperial, County of, California
- 449. Indio, City of, California
- 450. Inglewood, City of, California
- 451. Inyo, County of, California
- 452. Irvine, City of, California
- 453. Jurupa Valley, City of, California
- 454. Kerman, City of, California
- 455. Kern, County of, California
- 456. King City, City of, California
- 457. Kings, County of, California
- 458. Kingsburg, City of, California
- 459. La Cañada Flintridge, City of, California
- 460. La Habra, City of, California
- 461. La Mesa, City of, California
- 462. La Mirada, City of, California
- 463. La Palma, City of, California
- 464. La Puente, City of, California
- 465. La Quinta, City of, California
- 466. La Verne, City of, California
- 467. Lafayette, City of, California
- 468. Laguna Beach, City of, California
- 469. Laguna Hills, City of, California
- 470. Laguna Niguel, City of, California
- 471. Laguna Woods, City of, California
- 472. Lake, County of, California
- 473. Lake Elsinore, City of, California
- 474. Lake Forest, City of, California
- 475. Lakewood, City of, California
- 476. Lancaster, City of, California
- 477. Larkspur, City of, California
- 478. Lassen, County of, California
- 479. Lathrop, City of, California
- 480. Lawndale, City of, California
- 481. Lemon Grove, City of, California
- 482. Lemoore, City of, California
- 483. Lincoln, City of, California
- 484. Lindsay, City of, California
- 485. Livermore, City of, California
- 486. Livingston, City of, California
- 487. Lodi, City of, California
- 488. Loma Linda, City of, California
- 489. Lomita, City of, California
- 490. Lompoc, City of, California
- 491. Long Beach, City of, California
- 492. Los Alamitos, City of, California
- 493. Los Altos, City of, California
- 494. Los Angeles, City of, California
- 495. Los Angeles, County of, California
- 496. Los Banos, City of, California
- 497. Los Gatos, Town of, California
- 498. Lynwood, City of, California
- 499. Madera, City of, California
- 500. Madera, County of, California
- 501. Malibu, City of, California
- 502. Manhattan Beach, City of, California
- 503. Manteca, City of, California
- 504. Marin, County of, California
- 505. Marina, City of, California
- 506. Mariposa, County of, California
- 507. Martinez, City of, California
- 508. Marysville, City of, California
- 509. Maywood, City of, California
- 510. McFarland, City of, California
- 511. Mendocino, County of, California
- 512. Mendota, City of, California
- 513. Menifee, City of, California
- 514. Menlo Park, City of, California
- 515. Merced, City of, California
- 516. Merced, County of, California
- 517. Mill Valley, City of, California
- 518. Millbrae, City of, California
- 519. Milpitas, City of, California
- 520. Mission Viejo, City of, California
- 521. Modesto, City of, California
- 522. Mono, County of, California
- 523. Monrovia, City of, California
- 524. Montclair, City of, California
- 525. Montebello, City of, California
- 526. Monterey, City of, California
- 527. Monterey, County of, California
- 528. Monterey Park, City of, California
- 529. Moorpark, City of, California
- 530. Moraga, Town of, California
- 531. Moreno Valley, City of, California
- 532. Morgan Hill, City of, California
- 533. Morro Bay, City of, California
- 534. Mountain View, City of, California
- 535. Murrieta, City of, California

- 536. Napa, City of, California
- 537. Napa, County of, California
- 538. National City, City of, California
- 539. Nevada, County of, California
- 540. Newark, City of, California
- 541. Newman, City of, California
- 542. Newport Beach, City of, California
- 543. Norco, City of, California
- 544. Norwalk, City of, California
- 545. Novato, City of, California
- 546. Oakdale, City of, California
- 547. Oakland, City of, California
- 548. Oakley, City of, California
- 549. Oceanside, City of, California
- 550. Ontario, City of, California
- 551. Orange, City of, California
- 552. Orange, County of, California
- 553. Orange Cove, City of, California
- 554. Orinda, City of, California
- 555. Oroville, City of, California
- 556. Oxnard, City of, California
- 557. Pacific Grove, City of, California
- 558. Pacifica, City of, California
- 559. Palm Desert, City of, California
- 560. Palm Springs, City of, California
- 561. Palmdale, City of, California
- 562. Palo Alto, City of, California
- 563. Palos Verdes Estates, City of, California
- 564. Paramount, City of, California
- 565. Parlier, City of, California
- 566. Pasadena, City of, California
- 567. Patterson, City of, California
- 568. Perris, City of, California
- 569. Petaluma, City of, California
- 570. Pico Rivera, City of, California
- 571. Piedmont, City of, California
- 572. Pinole, City of, California
- 573. Pittsburg, City of, California
- 574. Placentia, City of, California
- 575. Placer, County of, California
- 576. Placerville, City of, California
- 577. Pleasant Hill, City of, California
- 578. Pleasanton, City of, California
- 579. Plumas, County of, California
- 580. Pomona, City of, California
- 581. Port Hueneme, City of, California
- 582. Porterville, City of, California
- 583. Poway, City of, California
- 584. Rancho Cordova, City of, California
- 585. Rancho Cucamonga, City of, California
- 586. Rancho Mirage, City of, California
- 587. Rancho Palos Verdes, City of, California
- 588. Rancho Santa Margarita, City of, California
- 589. Red Bluff, City of, California
- 590. Redding, City of, California
- 591. Redlands, City of, California
- 592. Redondo Beach, City of, California
- 593. Redwood City, City of, California
- 594. Reedley, City of, California
- 595. Rialto, City of, California
- 596. Richmond, City of, California
- 597. Ridgecrest, City of, California
- 598. Ripon, City of, California
- 599. Riverbank, City of, California
- 600. Riverside, City of, California
- 601. Riverside, County of, California
- 602. Rocklin, City of, California
- 603. Rohnert Park, City of, California
- 604. Rosemead, City of, California
- 605. Roseville, City of, California
- 606. Sacramento, City of, California
- 607. Sacramento, County of, California
- 608. Salinas, City of, California
- 609. San Anselmo, Town of, California
- 610. San Benito, County of, California
- 611. San Bernardino, City of, California
- 612. San Bernardino, County of, California
- 613. San Bruno, City of, California
- 614. San Buenaventura (Ventura), City of, California
- 615. San Carlos, City of, California
- 616. San Clemente, City of, California
- 617. San Diego, City of, California
- 618. San Diego, County of, California
- 619. San Dimas, City of, California
- 620. San Fernando, City of, California

- 621. San Francisco, City of/ County of, California
- 622. San Gabriel, City of, California
- 623. San Jacinto, City of, California
- 624. San Joaquin, County of, California
- 625. San Jose, City of, California
- 626. San Juan Capistrano, City of, California
- 627. San Leandro, City of, California
- 628. San Luis Obispo, City of, California
- 629. San Luis Obispo, County of, California
- 630. San Marcos, City of, California
- 631. San Marino, City of, California
- 632. San Mateo, City of, California
- 633. San Mateo, County of, California
- 634. San Pablo, City of, California
- 635. San Rafael, City of, California
- 636. San Ramon, City of, California
- 637. Sanger, City of, California
- 638. Santa Ana, City of, California
- 639. Santa Barbara, City of, California
- 640. Santa Barbara, County of, California
- 641. Santa Clara, City of, California
- 642. Santa Clara, County of, California
- 643. Santa Clarita, City of, California
- 644. Santa Cruz, City of, California
- 645. Santa Cruz, County of, California
- 646. Santa Fe Springs, City of, California
- 647. Santa Maria, City of, California
- 648. Santa Monica, City of, California
- 649. Santa Paula, City of, California
- 650. Santa Rosa, City of, California
- 651. Santee, City of, California
- 652. Saratoga, City of, California
- 653. Scotts Valley, City of, California
- 654. Seal Beach, City of, California
- 655. Seaside, City of, California
- 656. Selma, City of, California
- 657. Shafter, City of, California
- 658. Shasta, County of, California
- 659. Shasta Lake, City of, California
- 660. Sierra Madre, City of, California
- 661. Signal Hill, City of, California
- 662. Simi Valley, City of, California
- 663. Siskiyou, County of, California
- 664. Solana Beach, City of, California
- 665. Solano, County of, California
- 666. Soledad, City of, California
- 667. Sonoma, City of, California
- 668. Sonoma, County of, California
- 669. South El Monte, City of, California
- 670. South Gate, City of, California
- 671. South Lake Tahoe, City of, California
- 672. South Pasadena, City of, California
- 673. South San Francisco, City of, California
- 674. Stanislaus, County of, California
- 675. Stanton, City of, California
- 676. Stockton, City of, California
- 677. Suisun City, City of, California
- 678. Sunnyvale, City of, California
- 679. Susanville, City of, California
- 680. Sutter, County of, California
- 681. Tehachapi, City of, California
- 682. Tehama, County of, California
- 683. Temecula, City of, California
- 684. Temple City, City of, California
- 685. Thousand Oaks, City of, California
- 686. Torrance, City of, California
- 687. Tracy, City of, California
- 688. Trinity, County of, California
- 689. Truckee, Town of, California
- 690. Tulare, City of, California
- 691. Tulare, County of, California
- 692. Tuolumne, County of, California
- 693. Turlock, City of, California
- 694. Tustin, City of, California
- 695. Twentynine Palms, City of, California
- 696. Ukiah, City of, California
- 697. Union City, City of, California
- 698. Upland, City of, California
- 699. Vacaville, City of, California
- 700. Vallejo, City of, California
- 701. Ventura, County of, California
- 702. Victorville, City of, California
- 703. Visalia, City of, California
- 704. Vista, City of, California
- 705. Walnut, City of, California
- 706. Walnut Creek, City of, California

- 707. Wasco, City of, California
- 708. Watsonville, City of, California
- 709. West Covina, City of, California
- 710. West Hollywood, City of, California
- 711. West Sacramento, City of, California
- 712. Westminster, City of, California
- 713. Whittier, City of, California
- 714. Wildomar, City of, California
- 715. Windsor, Town of, California
- 716. Woodland, City of, California
- 717. Yolo, County of, California
- 718. Yorba Linda, City of, California
- 719. Yuba City, City of, California
- 720. Yuba, County of, California
- 721. Yucaipa, City of, California
- 722. Yucca Valley, Town of, California
- 723. Adams, County of, Colorado
- 724. Alamosa, County of, Colorado
- 725. Arapahoe, County of, Colorado
- 726. Archuleta, County of, Colorado
- 727. Arvada, City of, Colorado
- 728. Aurora, City of, Colorado
- 729. Boulder, City of, Colorado
- 730. Boulder, County of, Colorado
- 731. Brighton, City of, Colorado
- 732. Broomfield, City of/ County of, Colorado
- 733. Cañon City, City of, Colorado
- 734. Castle Pines, City of, Colorado
- 735. Castle Rock, Town of, Colorado
- 736. Centennial, City of, Colorado
- 737. Chaffee, County of, Colorado
- 738. Colorado Springs, City of, Colorado
- 739. Commerce City, City of, Colorado
- 740. Delta, County of, Colorado
- 741. Denver, City of/ County of, Colorado
- 742. Douglas, County of, Colorado
- 743. Durango, City of, Colorado
- 744. Eagle, County of, Colorado
- 745. El Paso, County of, Colorado
- 746. Elbert, County of, Colorado
- 747. Englewood, City of, Colorado
- 748. Erie, Town of, Colorado
- 749. Evans, City of, Colorado
- 750. Federal Heights, City of, Colorado
- 751. Firestone, Town of, Colorado
- 752. Fort Collins, City of, Colorado
- 753. Fort Morgan, City of, Colorado
- 754. Fountain, City of, Colorado
- 755. Frederick, Town of, Colorado
- 756. Fremont, County of, Colorado
- 757. Fruita, City of, Colorado
- 758. Garfield, County of, Colorado
- 759. Golden, City of, Colorado
- 760. Grand, County of, Colorado
- 761. Grand Junction, City of, Colorado
- 762. Greeley, City of, Colorado
- 763. Greenwood, Village of/ City of, Colorado
- 764. Gunnison, County of, Colorado
- 765. Jefferson, County of, Colorado
- 766. Johnstown, Town of, Colorado
- 767. La Plata, County of, Colorado
- 768. Lafayette, City of, Colorado
- 769. Lakewood, City of, Colorado
- 770. Larimer, County of, Colorado
- 771. Las Animas, County of, Colorado
- 772. Littleton, City of, Colorado
- 773. Logan, County of, Colorado
- 774. Lone Tree, City of, Colorado
- 775. Longmont, City of, Colorado
- 776. Louisville, City of, Colorado
- 777. Loveland, City of, Colorado
- 778. Mesa, County of, Colorado
- 779. Moffat, County of, Colorado
- 780. Montezuma, County of, Colorado
- 781. Montrose, City of, Colorado
- 782. Montrose, County of, Colorado
- 783. Morgan, County of, Colorado
- 784. Northglenn, City of, Colorado
- 785. Otero, County of, Colorado
- 786. Park, County of, Colorado
- 787. Parker, Town of, Colorado
- 788. Pitkin, County of, Colorado
- 789. Prowers, County of, Colorado
- 790. Pueblo, City of, Colorado
- 791. Pueblo, County of, Colorado
- 792. Rio Grande, County of, Colorado
- 793. Routt, County of, Colorado
- 794. Steamboat Springs, City of, Colorado

795. Sterling, City of, Colorado  
796. Summit, County of, Colorado  
797. Superior, Town of, Colorado  
798. Teller, County of, Colorado  
799. Thornton, City of, Colorado  
800. Weld, County of, Colorado  
801. Wellington, Town of, Colorado  
802. Westminster, City of, Colorado  
803. Wheat Ridge, City of, Colorado  
804. Windsor, Town of, Colorado  
805. Yuma, County of, Colorado  
806. Ansonia, Town of/ City of, Connecticut  
807. Avon, Town of, Connecticut  
808. Berlin, Town of, Connecticut  
809. Bethel, Town of, Connecticut  
810. Bloomfield, Town of, Connecticut  
811. Branford, Town of, Connecticut  
812. Bridgeport, Town of/ City of, Connecticut  
813. Bristol, City of/ Town of, Connecticut  
814. Brookfield, Town of, Connecticut  
815. Canton, Town of, Connecticut  
816. Cheshire, Town of, Connecticut  
817. Clinton, Town of, Connecticut  
818. Colchester, Town of, Connecticut  
819. Coventry, Town of, Connecticut  
820. Cromwell, Town of, Connecticut  
821. Danbury, City of/ Town of, Connecticut  
822. Darien, Town of, Connecticut  
823. Derby, City of/ Town of, Connecticut  
824. East Hampton, Town of, Connecticut  
825. East Hartford, Town of, Connecticut  
826. East Haven, Town of, Connecticut  
827. East Lyme, Town of, Connecticut  
828. East Windsor, Town of, Connecticut  
829. Ellington, Town of, Connecticut  
830. Enfield, Town of, Connecticut  
831. Fairfield, Town of, Connecticut  
832. Farmington, Town of, Connecticut  
833. Glastonbury, Town of, Connecticut  
834. Granby, Town of, Connecticut  
835. Greenwich, Town of, Connecticut  
836. Griswold, Town of, Connecticut  
837. Groton, Town of, Connecticut  
838. Guilford, Town of, Connecticut  
839. Hamden, Town of, Connecticut  
840. Hartford, City of/ Town of, Connecticut  
841. Killingly, Town of, Connecticut  
842. Ledyard, Town of, Connecticut  
843. Madison, Town of, Connecticut  
844. Manchester, Town of, Connecticut  
845. Mansfield, Town of, Connecticut  
846. Meriden, City of/ Town of, Connecticut  
847. Middletown, City of/ Town of, Connecticut  
848. Milford, City of, Connecticut  
849. Milford, Town of, Connecticut  
850. Monroe, Town of, Connecticut  
851. Montville, Town of, Connecticut  
852. Naugatuck, Borough of/ Town of, Connecticut  
853. New Britain, Town of/ City of, Connecticut  
854. New Canaan, Town of, Connecticut  
855. New Fairfield, Town of, Connecticut  
856. New Haven, Town of/ City of, Connecticut  
857. New London, City of/ Town of, Connecticut  
858. New Milford, Town of, Connecticut  
859. Newington, Town of, Connecticut  
860. Newtown, Town of, Connecticut  
861. North Branford, Town of, Connecticut  
862. North Haven, Town of, Connecticut  
863. Norwalk, City of/ Town of, Connecticut  
864. Norwich, City of/ Town of, Connecticut  
865. Old Saybrook, Town of, Connecticut  
866. Orange, Town of, Connecticut  
867. Oxford, Town of, Connecticut  
868. Plainfield, Town of, Connecticut  
869. Plainville, Town of, Connecticut  
870. Plymouth, Town of, Connecticut  
871. Ridgefield, Town of, Connecticut

- 872. Rocky Hill, Town of, Connecticut
- 873. Seymour, Town of, Connecticut
- 874. Shelton, City of/ Town of, Connecticut
- 875. Simsbury, Town of, Connecticut
- 876. Somers, Town of, Connecticut
- 877. South Windsor, Town of, Connecticut
- 878. Southbury, Town of, Connecticut
- 879. Southington, Town of, Connecticut
- 880. Stafford, Town of, Connecticut
- 881. Stamford, City of/ Town of, Connecticut
- 882. Stonington, Town of, Connecticut
- 883. Stratford, Town of, Connecticut
- 884. Suffield, Town of, Connecticut
- 885. Tolland, Town of, Connecticut
- 886. Torrington, City of/ Town of, Connecticut
- 887. Trumbull, Town of, Connecticut
- 888. Vernon, Town of, Connecticut
- 889. Wallingford, Town of, Connecticut
- 890. Waterbury, City of/ Town of, Connecticut
- 891. Waterford, Town of, Connecticut
- 892. Watertown, Town of, Connecticut
- 893. West Hartford, Town of, Connecticut
- 894. West Haven, City of/ Town of, Connecticut
- 895. Weston, Town of, Connecticut
- 896. Westport, Town of, Connecticut
- 897. Wethersfield, Town of, Connecticut
- 898. Wilton, Town of, Connecticut
- 899. Winchester, Town of, Connecticut
- 900. Windham, Town of, Connecticut
- 901. Windsor Locks, Town of, Connecticut
- 902. Windsor, Town of, Connecticut
- 903. Wolcott, Town of, Connecticut
- 904. Dover, City of, Delaware
- 905. Kent, County of, Delaware
- 906. Middletown, Town of, Delaware
- 907. Milford, City of, Delaware
- 908. New Castle, County of, Delaware
- 909. Newark, City of, Delaware
- 910. Smyrna, Town of, Delaware
- 911. Sussex, County of, Delaware
- 912. Wilmington, City of, Delaware
- 913. Alachua, County of, Florida
- 914. Altamonte Springs, City of, Florida
- 915. Apopka, City of, Florida
- 916. Atlantic Beach, City of, Florida
- 917. Auburndale, City of, Florida
- 918. Aventura, City of, Florida
- 919. Avon Park, City of, Florida
- 920. Baker, County of, Florida
- 921. Bartow, City of, Florida
- 922. Bay, County of, Florida
- 923. Belle Glade, City of, Florida
- 924. Boca Raton, City of, Florida
- 925. Bonita Springs, City of, Florida
- 926. Boynton Beach, City of, Florida
- 927. Bradenton, City of, Florida
- 928. Bradford, County of, Florida
- 929. Brevard, County of, Florida
- 930. Broward, County of, Florida
- 931. Calhoun, County of, Florida
- 932. Callaway, City of, Florida
- 933. Cape Canaveral, City of, Florida
- 934. Cape Coral, City of, Florida
- 935. Casselberry, City of, Florida
- 936. Charlotte, County of, Florida
- 937. Citrus, County of, Florida
- 938. Clay, County of, Florida
- 939. Clearwater, City of, Florida
- 940. Clermont, City of, Florida
- 941. Cocoa Beach, City of, Florida
- 942. Cocoa, City of, Florida
- 943. Coconut Creek, City of, Florida
- 944. Collier, County of, Florida
- 945. Columbia, County of, Florida
- 946. Cooper City, City of, Florida
- 947. Coral Gables, City of, Florida
- 948. Coral Springs, City of, Florida
- 949. Crestview, City of, Florida
- 950. Cutler Bay, Town of, Florida
- 951. Dania Beach, City of, Florida
- 952. Davie, Town of, Florida
- 953. Daytona Beach, City of, Florida
- 954. DeBary, City of, Florida
- 955. Deerfield Beach, City of, Florida
- 956. DeLand, City of, Florida



- 957. Delray Beach, City of, Florida
- 958. Deltona, City of, Florida
- 959. DeSoto, County of, Florida
- 960. Destin, City of, Florida
- 961. Dixie, County of, Florida
- 962. Doral, City of, Florida
- 963. Dunedin, City of, Florida
- 964. Duval, County of/ Jacksonville, City of, Florida
- 965. Edgewater, City of, Florida
- 966. Escambia, County of, Florida
- 967. Estero, Village of, Florida
- 968. Eustis, City of, Florida
- 969. Fernandina Beach, City of, Florida
- 970. Flagler, County of, Florida
- 971. Florida City, City of, Florida
- 972. Fort Lauderdale, City of, Florida
- 973. Fort Myers, City of, Florida
- 974. Fort Pierce, City of, Florida
- 975. Fort Walton Beach, City of, Florida
- 976. Franklin, County of, Florida
- 977. Fruitland Park, City of, Florida
- 978. Gadsden, County of, Florida
- 979. Gainesville, City of, Florida
- 980. Gilchrist, County of, Florida
- 981. Glades, County of, Florida
- 982. Greenacres, City of, Florida
- 983. Groveland, City of, Florida
- 984. Gulf, County of, Florida
- 985. Gulfport, City of, Florida
- 986. Haines City, City of, Florida
- 987. Hallandale Beach, City of, Florida
- 988. Hamilton, County of, Florida
- 989. Hardee, County of, Florida
- 990. Hendry, County of, Florida
- 991. Hernando, County of, Florida
- 992. Hialeah, City of, Florida
- 993. Hialeah Gardens, City of, Florida
- 994. Highlands, County of, Florida
- 995. Hillsborough, County of, Florida
- 996. Holly Hill, City of, Florida
- 997. Hollywood, City of, Florida
- 998. Holmes, County of, Florida
- 999. Homestead, City of, Florida
- 1000. Indian River, County of, Florida
- 1001. Jackson, County of, Florida
- 1002. Jacksonville Beach, City of, Florida
- 1003. Jefferson, County of, Florida
- 1004. Jupiter, Town of, Florida
- 1005. Key Biscayne, Village of, Florida
- 1006. Key West, City of, Florida
- 1007. Kissimmee, City of, Florida
- 1008. Lady Lake, Town of, Florida
- 1009. Lake City, City of, Florida
- 1010. Lake, County of, Florida
- 1011. Lake Mary, City of, Florida
- 1012. Lake Wales, City of, Florida
- 1013. Lake Worth, City of, Florida
- 1014. Lakeland, City of, Florida
- 1015. Lantana, Town of, Florida
- 1016. Largo, City of, Florida
- 1017. Lauderdale Lakes, City of, Florida
- 1018. Lauderhill, City of, Florida
- 1019. Lee, County of, Florida
- 1020. Leesburg, City of, Florida
- 1021. Leon, County of, Florida
- 1022. Levy, County of, Florida
- 1023. Lighthouse Point, City of, Florida
- 1024. Longwood, City of, Florida
- 1025. Lynn Haven, City of, Florida
- 1026. Madison, County of, Florida
- 1027. Maitland, City of, Florida
- 1028. Manatee, County of, Florida
- 1029. Marco Island, City of, Florida
- 1030. Margate, City of, Florida
- 1031. Marion, County of, Florida
- 1032. Martin, County of, Florida
- 1033. Melbourne, City of, Florida
- 1034. Miami Beach, City of, Florida
- 1035. Miami, City of, Florida
- 1036. Miami Gardens, City of, Florida
- 1037. Miami Lakes, Town of, Florida
- 1038. Miami Shores, Village of, Florida
- 1039. Miami Springs, City of, Florida
- 1040. Miami-Dade, County of, Florida
- 1041. Milton, City of, Florida
- 1042. Minneola, City of, Florida
- 1043. Miramar, City of, Florida
- 1044. Monroe, County of, Florida
- 1045. Mount Dora, City of, Florida
- 1046. Naples, City of, Florida
- 1047. Nassau, County of, Florida

- 1048. New Port Richey, City of, Florida
- 1049. New Smyrna Beach, City of, Florida
- 1050. Niceville, City of, Florida
- 1051. North Lauderdale, City of, Florida
- 1052. North Miami Beach, City of, Florida
- 1053. North Miami, City of, Florida
- 1054. North Palm Beach, Village of, Florida
- 1055. North Port, City of, Florida
- 1056. Oakland Park, City of, Florida
- 1057. Ocala, City of, Florida
- 1058. Ocoee, City of, Florida
- 1059. Okaloosa, County of, Florida
- 1060. Okeechobee, County of, Florida
- 1061. Oldsmar, City of, Florida
- 1062. Opa-locka, City of, Florida
- 1063. Orange City, City of, Florida
- 1064. Orange, County of, Florida
- 1065. Orlando, City of, Florida
- 1066. Ormond Beach, City of, Florida
- 1067. Osceola, County of, Florida
- 1068. Oviedo, City of, Florida
- 1069. Palatka, City of, Florida
- 1070. Palm Bay, City of, Florida
- 1071. Palm Beach, County of, Florida
- 1072. Palm Beach Gardens, City of, Florida
- 1073. Palm Coast, City of, Florida
- 1074. Palm Springs, Village of, Florida
- 1075. Palmetto Bay, Village of, Florida
- 1076. Palmetto, City of, Florida
- 1077. Panama City Beach, City of, Florida
- 1078. Panama City, City of, Florida
- 1079. Parkland, City of, Florida
- 1080. Pasco, County of, Florida
- 1081. Pembroke Pines, City of, Florida
- 1082. Pensacola, City of, Florida
- 1083. Pinecrest, Village of, Florida
- 1084. Pinellas, County of, Florida
- 1085. Pinellas Park, City of, Florida
- 1086. Plant City, City of, Florida
- 1087. Plantation, City of, Florida
- 1088. Polk, County of, Florida
- 1089. Pompano Beach, City of, Florida
- 1090. Port Orange, City of, Florida
- 1091. Port St. Lucie, City of, Florida
- 1092. Punta Gorda, City of, Florida
- 1093. Putnam, County of, Florida
- 1094. Riviera Beach, City of, Florida
- 1095. Rockledge, City of, Florida
- 1096. Royal Palm Beach, Village of, Florida
- 1097. Safety Harbor, City of, Florida
- 1098. Sanford, City of, Florida
- 1099. Santa Rosa, County of, Florida
- 1100. Sarasota, City of, Florida
- 1101. Sarasota, County of, Florida
- 1102. Satellite Beach, City of, Florida
- 1103. Sebastian, City of, Florida
- 1104. Sebring, City of, Florida
- 1105. Seminole, City of, Florida
- 1106. Seminole, County of, Florida
- 1107. South Daytona, City of, Florida
- 1108. South Miami, City of, Florida
- 1109. St. Augustine, City of, Florida
- 1110. St. Cloud, City of, Florida
- 1111. St. Johns, County of, Florida
- 1112. St. Lucie, County of, Florida
- 1113. St. Petersburg, City of, Florida
- 1114. Stuart, City of, Florida
- 1115. Sumter, County of, Florida
- 1116. Sunny Isles Beach, City of, Florida
- 1117. Sunrise, City of, Florida
- 1118. Suwannee, County of, Florida
- 1119. Sweetwater, City of, Florida
- 1120. Tallahassee, City of, Florida
- 1121. Tamarac, City of, Florida
- 1122. Tampa, City of, Florida
- 1123. Tarpon Springs, City of, Florida
- 1124. Tavares, City of, Florida
- 1125. Taylor, County of, Florida
- 1126. Temple Terrace, City of, Florida
- 1127. Titusville, City of, Florida
- 1128. Union, County of, Florida
- 1129. Venice, City of, Florida
- 1130. Vero Beach, City of, Florida
- 1131. Volusia, County of, Florida
- 1132. Wakulla, County of, Florida
- 1133. Walton, County of, Florida
- 1134. Washington, County of, Florida
- 1135. Wellington, Village of, Florida
- 1136. West Melbourne, City of, Florida

- 1137. West Palm Beach, City of, Florida
- 1138. West Park, City of, Florida
- 1139. Weston, City of, Florida
- 1140. Wilton Manors, City of, Florida
- 1141. Winter Garden, City of, Florida
- 1142. Winter Haven, City of, Florida
- 1143. Winter Park, City of, Florida
- 1144. Winter Springs, City of, Florida
- 1145. Zephyrhills, City of, Florida
- 1146. Acworth, City of, Georgia
- 1147. Albany, City of, Georgia
- 1148. Alpharetta, City of, Georgia
- 1149. Americus, City of, Georgia
- 1150. Appling, County of, Georgia
- 1151. Athens-Clarke County, Unified Government of, Georgia
- 1152. Atlanta, City of, Georgia
- 1153. Augusta-Richmond County, Consolidated Government of, Georgia
- 1154. Bacon, County of, Georgia
- 1155. Bainbridge, City of, Georgia
- 1156. Baldwin, County of, Georgia
- 1157. Banks, County of, Georgia
- 1158. Barrow, County of, Georgia
- 1159. Bartow, County of, Georgia
- 1160. Ben Hill, County of, Georgia
- 1161. Berrien, County of, Georgia
- 1162. Bleckley, County of, Georgia
- 1163. Brantley, County of, Georgia
- 1164. Braselton, Town of, Georgia
- 1165. Brookhaven, City of, Georgia
- 1166. Brooks, County of, Georgia
- 1167. Brunswick, City of, Georgia
- 1168. Bryan, County of, Georgia
- 1169. Buford, City of, Georgia
- 1170. Bulloch, County of, Georgia
- 1171. Burke, County of, Georgia
- 1172. Butts, County of, Georgia
- 1173. Calhoun, City of, Georgia
- 1174. Camden, County of, Georgia
- 1175. Candler, County of, Georgia
- 1176. Canton, City of, Georgia
- 1177. Carroll, County of, Georgia
- 1178. Carrollton, City of, Georgia
- 1179. Cartersville, City of, Georgia
- 1180. Catoosa, County of, Georgia
- 1181. Chamblee, City of, Georgia
- 1182. Charlton, County of, Georgia
- 1183. Chatham, County of, Georgia
- 1184. Chattooga, County of, Georgia
- 1185. Cherokee, County of, Georgia
- 1186. Clarkston, City of, Georgia
- 1187. Clayton, County of, Georgia
- 1188. Cobb, County of, Georgia
- 1189. Coffee, County of, Georgia
- 1190. College Park, City of, Georgia
- 1191. Colquitt, County of, Georgia
- 1192. Columbia, County of, Georgia
- 1193. Columbus, City of, Georgia
- 1194. Columbus, City of/ Muscogee, County of, Georgia
- 1195. Conyers, City of, Georgia
- 1196. Cook, County of, Georgia
- 1197. Cordele, City of, Georgia
- 1198. Covington, City of, Georgia
- 1199. Coweta, County of, Georgia
- 1200. Crawford, County of, Georgia
- 1201. Crisp, County of, Georgia
- 1202. Cusseta-Chattahoochee County, Unified Government of, Georgia
- 1203. Dade, County of, Georgia
- 1204. Dallas, City of, Georgia
- 1205. Dalton, City of, Georgia
- 1206. Dawson, County of, Georgia
- 1207. Decatur, City of, Georgia
- 1208. Decatur, County of, Georgia
- 1209. DeKalb, County of, Georgia
- 1210. Dodge, County of, Georgia
- 1211. Dooly, County of, Georgia
- 1212. Doraville, City of, Georgia
- 1213. Dougherty, County of, Georgia
- 1214. Douglas, City of, Georgia
- 1215. Douglas, County of, Georgia
- 1216. Douglasville, City of, Georgia
- 1217. Dublin, City of, Georgia
- 1218. Duluth, City of, Georgia
- 1219. Dunwoody, City of, Georgia
- 1220. Early, County of, Georgia
- 1221. East Point, City of, Georgia
- 1222. Effingham, County of, Georgia
- 1223. Elbert, County of, Georgia

- 1224. Emanuel, County of, Georgia
- 1225. Evans, County of, Georgia
- 1226. Fairburn, City of, Georgia
- 1227. Fannin, County of, Georgia
- 1228. Fayette, County of, Georgia
- 1229. Fayetteville, City of, Georgia
- 1230. Floyd, County of, Georgia
- 1231. Forest Park, City of, Georgia
- 1232. Forsyth, County of, Georgia
- 1233. Franklin, County of, Georgia
- 1234. Fulton, County of, Georgia
- 1235. Gainesville, City of, Georgia
- 1236. Gilmer, County of, Georgia
- 1237. Glynn, County of, Georgia
- 1238. Gordon, County of, Georgia
- 1239. Grady, County of, Georgia
- 1240. Greene, County of, Georgia
- 1241. Griffin, City of, Georgia
- 1242. Grovetown, City of, Georgia
- 1243. Gwinnett, County of, Georgia
- 1244. Habersham, County of, Georgia
- 1245. Hall, County of, Georgia
- 1246. Haralson, County of, Georgia
- 1247. Harris, County of, Georgia
- 1248. Hart, County of, Georgia
- 1249. Heard, County of, Georgia
- 1250. Henry, County of, Georgia
- 1251. Hinesville, City of, Georgia
- 1252. Holly Springs, City of, Georgia
- 1253. Houston, County of, Georgia
- 1254. Jackson, County of, Georgia
- 1255. Jasper, County of, Georgia
- 1256. Jeff Davis, County of, Georgia
- 1257. Jefferson, City of, Georgia
- 1258. Jefferson, County of, Georgia
- 1259. Johns Creek, City of, Georgia
- 1260. Jones, County of, Georgia
- 1261. Kennesaw, City of, Georgia
- 1262. Kingsland, City of, Georgia
- 1263. LaGrange, City of, Georgia
- 1264. Lamar, County of, Georgia
- 1265. Lanier, County of, Georgia
- 1266. Laurens, County of, Georgia
- 1267. Lawrenceville, City of, Georgia
- 1268. Lee, County of, Georgia
- 1269. Liberty, County of, Georgia
- 1270. Lilburn, City of, Georgia
- 1271. Loganville, City of, Georgia
- 1272. Long, County of, Georgia
- 1273. Lowndes, County of, Georgia
- 1274. Lumpkin, County of, Georgia
- 1275. Macon, County of, Georgia
- 1276. Macon-Bibb, County of, Georgia
- 1277. Madison, County of, Georgia
- 1278. Marietta, City of, Georgia
- 1279. McDonough, City of, Georgia
- 1280. McDuffie, County of, Georgia
- 1281. McIntosh, County of, Georgia
- 1282. Meriwether, County of, Georgia
- 1283. Milledgeville, City of, Georgia
- 1284. Milton, City of, Georgia
- 1285. Mitchell, County of, Georgia
- 1286. Monroe, City of, Georgia
- 1287. Monroe, County of, Georgia
- 1288. Morgan, County of, Georgia
- 1289. Moultrie, City of, Georgia
- 1290. Murray, County of, Georgia
- 1291. Newnan, City of, Georgia
- 1292. Newton, County of, Georgia
- 1293. Norcross, City of, Georgia
- 1294. Oconee, County of, Georgia
- 1295. Oglethorpe, County of, Georgia
- 1296. Paulding, County of, Georgia
- 1297. Peach, County of, Georgia
- 1298. Peachtree City, City of, Georgia
- 1299. Peachtree Corners, City of, Georgia
- 1300. Perry, City of, Georgia
- 1301. Pickens, County of, Georgia
- 1302. Pierce, County of, Georgia
- 1303. Pike, County of, Georgia
- 1304. Polk, County of, Georgia
- 1305. Pooler, City of, Georgia
- 1306. Powder Springs, City of, Georgia
- 1307. Pulaski, County of, Georgia
- 1308. Putnam, County of, Georgia
- 1309. Rabun, County of, Georgia
- 1310. Richmond Hill, City of, Georgia
- 1311. Rincon, City of, Georgia
- 1312. Riverdale, City of, Georgia
- 1313. Rockdale, County of, Georgia
- 1314. Rome, City of, Georgia
- 1315. Roswell, City of, Georgia

- 1316. Sandy Springs, City of, Georgia
- 1317. Savannah, City of, Georgia
- 1318. Screven, County of, Georgia
- 1319. Smyrna, City of, Georgia
- 1320. Snellville, City of, Georgia
- 1321. South Fulton, City of, Georgia
- 1322. Spalding, County of, Georgia
- 1323. St. Marys, City of, Georgia
- 1324. Statesboro, City of, Georgia
- 1325. Stephens, County of, Georgia
- 1326. Stockbridge, City of, Georgia
- 1327. Stonecrest, City of, Georgia
- 1328. Sugar Hill, City of, Georgia
- 1329. Sumter, County of, Georgia
- 1330. Suwanee, City of, Georgia
- 1331. Tattnall, County of, Georgia
- 1332. Telfair, County of, Georgia
- 1333. Thomas, County of, Georgia
- 1334. Thomasville, City of, Georgia
- 1335. Tift, County of, Georgia
- 1336. Tifton, City of, Georgia
- 1337. Toombs, County of, Georgia
- 1338. Towns, County of, Georgia
- 1339. Troup, County of, Georgia
- 1340. Tucker, City of, Georgia
- 1341. Union City, City of, Georgia
- 1342. Union, County of, Georgia
- 1343. Upson, County of, Georgia
- 1344. Valdosta, City of, Georgia
- 1345. Vidalia, City of, Georgia
- 1346. Villa Rica, City of, Georgia
- 1347. Walker, County of, Georgia
- 1348. Walton, County of, Georgia
- 1349. Ware, County of, Georgia
- 1350. Warner Robins, City of, Georgia
- 1351. Washington, County of, Georgia
- 1352. Waycross, City of, Georgia
- 1353. Wayne, County of, Georgia
- 1354. White, County of, Georgia
- 1355. Whitfield, County of, Georgia
- 1356. Winder, City of, Georgia
- 1357. Woodstock, City of, Georgia
- 1358. Worth, County of, Georgia
- 1359. Hawaii, County of, Hawaii
- 1360. Honolulu, County of/ City of, Hawaii
- 1361. Kauai, County of, Hawaii
- 1362. Maui, County of, Hawaii
- 1363. Ada, County of, Idaho
- 1364. Ammon, City of, Idaho
- 1365. Bannock, County of, Idaho
- 1366. Bingham, County of, Idaho
- 1367. Blackfoot, City of, Idaho
- 1368. Blaine, County of, Idaho
- 1369. Boise City, City of, Idaho
- 1370. Bonner, County of, Idaho
- 1371. Bonneville, County of, Idaho
- 1372. Boundary, County of, Idaho
- 1373. Burley, City of, Idaho
- 1374. Caldwell, City of, Idaho
- 1375. Canyon, County of, Idaho
- 1376. Cassia, County of, Idaho
- 1377. Chubbuck, City of, Idaho
- 1378. Coeur d'Alene, City of, Idaho
- 1379. Eagle, City of, Idaho
- 1380. Elmore, County of, Idaho
- 1381. Franklin, County of, Idaho
- 1382. Fremont, County of, Idaho
- 1383. Garden City, City of, Idaho
- 1384. Gem, County of, Idaho
- 1385. Gooding, County of, Idaho
- 1386. Hayden, City of, Idaho
- 1387. Idaho, County of, Idaho
- 1388. Idaho Falls, City of, Idaho
- 1389. Jefferson, County of, Idaho
- 1390. Jerome, City of, Idaho
- 1391. Jerome, County of, Idaho
- 1392. Kootenai, County of, Idaho
- 1393. Kuna, City of, Idaho
- 1394. Latah, County of, Idaho
- 1395. Lewiston, City of, Idaho
- 1396. Madison, County of, Idaho
- 1397. Meridian, City of, Idaho
- 1398. Minidoka, County of, Idaho
- 1399. Moscow, City of, Idaho
- 1400. Mountain Home, City of, Idaho
- 1401. Nampa, City of, Idaho
- 1402. Nez Perce, County of, Idaho
- 1403. Owyhee, County of, Idaho
- 1404. Payette, County of, Idaho
- 1405. Pocatello, City of, Idaho
- 1406. Post Falls, City of, Idaho

- 1407. Rexburg, City of, Idaho
- 1408. Shoshone, County of, Idaho
- 1409. Star, City of, Idaho
- 1410. Teton, County of, Idaho
- 1411. Twin Falls, City of, Idaho
- 1412. Twin Falls, County of, Idaho
- 1413. Valley, County of, Idaho
- 1414. Washington, County of, Idaho
- 1415. Adams, County of, Illinois
- 1416. Addison Township, Illinois
- 1417. Addison, Village of, Illinois
- 1418. Algonquin Township, Illinois
- 1419. Algonquin, Village of, Illinois
- 1420. Alsip, Village of, Illinois
- 1421. Alton, City of, Illinois
- 1422. Alton Township, Illinois
- 1423. Antioch Township, Illinois
- 1424. Antioch, Village of, Illinois
- 1425. Arlington Heights, Village of, Illinois
- 1426. Aurora, City of, Illinois
- 1427. Aurora Township, Illinois
- 1428. Aux Sable Township, Illinois
- 1429. Avon Township, Illinois
- 1430. Barrington Township, Illinois
- 1431. Barrington, Village of, Illinois
- 1432. Bartlett, Village of, Illinois
- 1433. Batavia, City of, Illinois
- 1434. Batavia Township, Illinois
- 1435. Beach Park, Village of, Illinois
- 1436. Belleville, City of, Illinois
- 1437. Bellwood, Village of, Illinois
- 1438. Belvidere, City of, Illinois
- 1439. Belvidere Township, Illinois
- 1440. Bensenville, Village of, Illinois
- 1441. Benton Township, Illinois
- 1442. Berwyn, City of, Illinois
- 1443. Berwyn Township, Illinois
- 1444. Blackberry Township, Illinois
- 1445. Bloom Township, Illinois
- 1446. Bloomingdale Township, Illinois
- 1447. Bloomingdale, Village of, Illinois
- 1448. Bloomington, City of, Illinois
- 1449. Bloomington City Township, Illinois
- 1450. Blue Island, City of, Illinois
- 1451. Bolingbrook, Village of, Illinois
- 1452. Bond, County of, Illinois
- 1453. Boone, County of, Illinois
- 1454. Bourbonnais Township, Illinois
- 1455. Bourbonnais, Village of, Illinois
- 1456. Bradley, Village of, Illinois
- 1457. Bremen Township, Illinois
- 1458. Bridgeview, Village of, Illinois
- 1459. Bristol Township, Illinois
- 1460. Brookfield, Village of, Illinois
- 1461. Bruce Township, Illinois
- 1462. Buffalo Grove, Village of, Illinois
- 1463. Burbank, City of, Illinois
- 1464. Bureau, County of, Illinois
- 1465. Burr Ridge, Village of, Illinois
- 1466. Cahokia, Village of, Illinois
- 1467. Calumet City, City of, Illinois
- 1468. Calumet Township, Illinois
- 1469. Campton Hills, Village of, Illinois
- 1470. Campton Township, Illinois
- 1471. Canton, City of, Illinois
- 1472. Canton Township, Illinois
- 1473. Capital Township, Illinois
- 1474. Carbondale, City of, Illinois
- 1475. Carbondale Township, Illinois
- 1476. Carol Stream, Village of, Illinois
- 1477. Carpentersville, Village of, Illinois
- 1478. Carroll, County of, Illinois
- 1479. Cary, Village of, Illinois
- 1480. Caseyville Township, Illinois
- 1481. Cass, County of, Illinois
- 1482. Centralia, City of, Illinois
- 1483. Centralia Township, Illinois
- 1484. Centreville Township, Illinois
- 1485. Champaign, City of, Illinois
- 1486. Champaign City Township, Illinois
- 1487. Champaign, County of, Illinois
- 1488. Champaign Township, Illinois
- 1489. Channahon Township, Illinois
- 1490. Channahon, Village of, Illinois
- 1491. Charleston, City of, Illinois
- 1492. Charleston Township, Illinois
- 1493. Chatham, Village of, Illinois
- 1494. Cherry Valley Township, Illinois
- 1495. Chicago, City of, Illinois
- 1496. Chicago Heights, City of, Illinois
- 1497. Chicago Ridge, Village of, Illinois

- 1498. Christian, County of, Illinois
- 1499. Cicero, Town of/ Township of, Illinois
- 1500. Clark, County of, Illinois
- 1501. Clay, County of, Illinois
- 1502. Clinton, County of, Illinois
- 1503. Coles, County of, Illinois
- 1504. Collinsville, City of, Illinois
- 1505. Collinsville Township, Illinois
- 1506. Coloma Township, Illinois
- 1507. Columbia, City of, Illinois
- 1508. Cook, County of, Illinois
- 1509. Cortland Township, Illinois
- 1510. Country Club Hills, City of, Illinois
- 1511. Crawford, County of, Illinois
- 1512. Crest Hill, City of, Illinois
- 1513. Crestwood, Village of, Illinois
- 1514. Crete Township, Illinois
- 1515. Crystal Lake, City of, Illinois
- 1516. Cuba Township, Illinois
- 1517. Cumberland, County of, Illinois
- 1518. Cunningham Township, Illinois
- 1519. Danville, City of, Illinois
- 1520. Danville Township, Illinois
- 1521. Darien, City of, Illinois
- 1522. De Witt, County of, Illinois
- 1523. Decatur, City of, Illinois
- 1524. Decatur Township, Illinois
- 1525. Deerfield, Village of, Illinois
- 1526. DeKalb, City of, Illinois
- 1527. DeKalb, County of, Illinois
- 1528. DeKalb Township, Illinois
- 1529. Des Plaines, City of, Illinois
- 1530. Dixon, City of, Illinois
- 1531. Dixon Township, Illinois
- 1532. Dolton, Village of, Illinois
- 1533. Dorr Township, Illinois
- 1534. Douglas, County of, Illinois
- 1535. Douglas Township, Illinois
- 1536. Downers Grove Township, Illinois
- 1537. Downers Grove, Village of, Illinois
- 1538. Du Page Township, Illinois
- 1539. Dundee Township, Illinois
- 1540. DuPage, County of, Illinois
- 1541. East Moline, City of, Illinois
- 1542. East Peoria, City of, Illinois
- 1543. East St. Louis, City of, Illinois
- 1544. East St. Louis Township, Illinois
- 1545. Edgar, County of, Illinois
- 1546. Edwardsville, City of, Illinois
- 1547. Edwardsville Township, Illinois
- 1548. Effingham, City of, Illinois
- 1549. Effingham, County of, Illinois
- 1550. Ela Township, Illinois
- 1551. Elgin, City of, Illinois
- 1552. Elgin Township, Illinois
- 1553. Elk Grove Township, Illinois
- 1554. Elk Grove Village, Village of, Illinois
- 1555. Elmhurst, City of, Illinois
- 1556. Elmwood Park, Village of, Illinois
- 1557. Evanston, City of, Illinois
- 1558. Evergreen Park, Village of, Illinois
- 1559. Fairview Heights, City of, Illinois
- 1560. Fayette, County of, Illinois
- 1561. Flagg Township, Illinois
- 1562. Fondulac Township, Illinois
- 1563. Ford, County of, Illinois
- 1564. Forest Park, Village of, Illinois
- 1565. Fox Lake, Village of, Illinois
- 1566. Frankfort Township, Illinois
- 1567. Frankfort, Village of, Illinois
- 1568. Franklin, County of, Illinois
- 1569. Franklin Park, Village of, Illinois
- 1570. Freeport, City of, Illinois
- 1571. Freeport Township, Illinois
- 1572. Fremont Township, Illinois
- 1573. Fulton, County of, Illinois
- 1574. Galesburg, City of, Illinois
- 1575. Galesburg City Township, Illinois
- 1576. Geneva, City of, Illinois
- 1577. Geneva Township, Illinois
- 1578. Glen Carbon, Village of, Illinois
- 1579. Glen Ellyn, Village of, Illinois
- 1580. Glendale Heights, Village of, Illinois
- 1581. Glenview, Village of, Illinois
- 1582. Godfrey Township, Illinois
- 1583. Godfrey, Village of, Illinois
- 1584. Grafton Township, Illinois
- 1585. Granite City, City of, Illinois
- 1586. Granite City Township, Illinois
- 1587. Grant Township, Illinois

- 1588. Grayslake, Village of, Illinois
- 1589. Greene, County of, Illinois
- 1590. Greenwood Township, Illinois
- 1591. Groveland Township, Illinois
- 1592. Grundy, County of, Illinois
- 1593. Gurnee, Village of, Illinois
- 1594. Hampton Township, Illinois
- 1595. Hancock, County of, Illinois
- 1596. Hanover Park, Village of, Illinois
- 1597. Hanover Township, Illinois
- 1598. Harlem Township, Illinois
- 1599. Harrisburg Township, Illinois
- 1600. Harvey, City of, Illinois
- 1601. Hazel Crest, Village of, Illinois
- 1602. Henry, County of, Illinois
- 1603. Herrin, City of, Illinois
- 1604. Hickory Hills, City of, Illinois
- 1605. Hickory Point Township, Illinois
- 1606. Highland Park, City of, Illinois
- 1607. Hinsdale, Village of, Illinois
- 1608. Hoffman Estates, Village of, Illinois
- 1609. Homer Glen, Village of, Illinois
- 1610. Homer Township, Illinois
- 1611. Homewood, Village of, Illinois
- 1612. Huntley, Village of, Illinois
- 1613. Iroquois, County of, Illinois
- 1614. Jackson, County of, Illinois
- 1615. Jacksonville, City of, Illinois
- 1616. Jarvis Township, Illinois
- 1617. Jefferson, County of, Illinois
- 1618. Jersey, County of, Illinois
- 1619. Jo Daviess, County of, Illinois
- 1620. Johnson, County of, Illinois
- 1621. Joliet, City of, Illinois
- 1622. Joliet Township, Illinois
- 1623. Justice, Village of, Illinois
- 1624. Kane, County of, Illinois
- 1625. Kankakee, City of, Illinois
- 1626. Kankakee, County of, Illinois
- 1627. Kankakee Township, Illinois
- 1628. Kendall, County of, Illinois
- 1629. Kewanee, City of, Illinois
- 1630. Knox, County of, Illinois
- 1631. La Grange Park, Village of, Illinois
- 1632. La Grange, Village of, Illinois
- 1633. Lake, County of, Illinois
- 1634. Lake Forest, City of, Illinois
- 1635. Lake in the Hills, Village of, Illinois
- 1636. Lake Villa Township, Illinois
- 1637. Lake Zurich, Village of, Illinois
- 1638. Lansing, Village of, Illinois
- 1639. LaSalle, County of, Illinois
- 1640. LaSalle Township, Illinois
- 1641. Lawrence, County of, Illinois
- 1642. Lee, County of, Illinois
- 1643. Lemont Township, Illinois
- 1644. Lemont, Village of, Illinois
- 1645. Leyden Township, Illinois
- 1646. Libertyville Township, Illinois
- 1647. Libertyville, Village of, Illinois
- 1648. Limestone Township, Illinois
- 1649. Lincoln, City of, Illinois
- 1650. Lincolnwood, Village of, Illinois
- 1651. Lindenhurst, Village of, Illinois
- 1652. Lisle Township, Illinois
- 1653. Lisle, Village of, Illinois
- 1654. Little Rock Township, Illinois
- 1655. Livingston, County of, Illinois
- 1656. Lockport, City of, Illinois
- 1657. Lockport Township, Illinois
- 1658. Logan, County of, Illinois
- 1659. Lombard, Village of, Illinois
- 1660. Long Creek Township, Illinois
- 1661. Loves Park, City of, Illinois
- 1662. Lyons Township, Illinois
- 1663. Lyons, Village of, Illinois
- 1664. Machesney Park, Village of, Illinois
- 1665. Macomb, City of, Illinois
- 1666. Macomb City Township, Illinois
- 1667. Macon, County of, Illinois
- 1668. Macoupin, County of, Illinois
- 1669. Madison, County of, Illinois
- 1670. Mahomet Township, Illinois
- 1671. Maine Township, Illinois
- 1672. Manhattan Township, Illinois
- 1673. Manteno Township, Illinois
- 1674. Marion, City of, Illinois
- 1675. Marion, County of, Illinois
- 1676. Markham, City of, Illinois
- 1677. Marshall, County of, Illinois
- 1678. Mason, County of, Illinois
- 1679. Massac, County of, Illinois



- 1680. Matteson, Village of, Illinois
- 1681. Mattoon, City of, Illinois
- 1682. Mattoon, Township of, Illinois
- 1683. Maywood, Village of, Illinois
- 1684. McDonough, County of, Illinois
- 1685. McHenry, City of, Illinois
- 1686. McHenry, County of, Illinois
- 1687. McHenry, Township of, Illinois
- 1688. McLean, County of, Illinois
- 1689. Medina, Township of, Illinois
- 1690. Melrose Park, Village of, Illinois
- 1691. Menard, County of, Illinois
- 1692. Mercer, County of, Illinois
- 1693. Midlothian, Village of, Illinois
- 1694. Milton Township, Illinois
- 1695. Minooka, Village of, Illinois
- 1696. Mokena, Village of, Illinois
- 1697. Moline, City of, Illinois
- 1698. Moline, Township of, Illinois
- 1699. Monee, Township of, Illinois
- 1700. Monroe, County of, Illinois
- 1701. Montgomery, County of, Illinois
- 1702. Montgomery, Village of, Illinois
- 1703. Moraine, Township of, Illinois
- 1704. Morgan, County of, Illinois
- 1705. Morris, City of, Illinois
- 1706. Morton Grove, Village of, Illinois
- 1707. Morton, Township of, Illinois
- 1708. Morton, Village of, Illinois
- 1709. Moultrie, County of, Illinois
- 1710. Mount Prospect, Village of, Illinois
- 1711. Mount Vernon, City of, Illinois
- 1712. Mount Vernon, Township of, Illinois
- 1713. Mundelein, Village of, Illinois
- 1714. Nameoki, Township of, Illinois
- 1715. Naperville, City of, Illinois
- 1716. Naperville, Township of, Illinois
- 1717. New Lenox, Township of, Illinois
- 1718. New Lenox, Village of, Illinois
- 1719. New Trier, Township of, Illinois
- 1720. Newell, Township of, Illinois
- 1721. Niles, Township of, Illinois
- 1722. Niles, Village of, Illinois
- 1723. Normal, Town of, Illinois
- 1724. Normal, Township of, Illinois
- 1725. Norridge, Village of, Illinois
- 1726. North Aurora, Village of, Illinois
- 1727. North Chicago, City of, Illinois
- 1728. Northbrook, Village of, Illinois
- 1729. Northfield, Township of, Illinois
- 1730. Northlake, City of, Illinois
- 1731. Norwood Park, Township of, Illinois
- 1732. Nunda, Township of, Illinois
- 1733. Oak Forest, City of, Illinois
- 1734. Oak Lawn, Village of, Illinois
- 1735. Oak Park, Township of, Illinois
- 1736. Oak Park, Village of, Illinois
- 1737. O'Fallon, City of, Illinois
- 1738. O'Fallon, Township of, Illinois
- 1739. Ogle, County of, Illinois
- 1740. Orland Park, Village of, Illinois
- 1741. Orland, Township of, Illinois
- 1742. Oswego, Township of, Illinois
- 1743. Oswego, Village of, Illinois
- 1744. Ottawa, City of, Illinois
- 1745. Ottawa, Township of, Illinois
- 1746. Palatine, Township of, Illinois
- 1747. Palatine, Village of, Illinois
- 1748. Palos Heights, City of, Illinois
- 1749. Palos Hills, City of, Illinois
- 1750. Palos, Township of, Illinois
- 1751. Park Forest, Village of, Illinois
- 1752. Park Ridge, City of, Illinois
- 1753. Pekin, City of, Illinois
- 1754. Pekin, Township of, Illinois
- 1755. Peoria, City of, Illinois
- 1756. Peoria City Township, Illinois
- 1757. Peoria, County of, Illinois
- 1758. Perry, County of, Illinois
- 1759. Peru, Township of, Illinois
- 1760. Piatt, County of, Illinois
- 1761. Pike, County of, Illinois
- 1762. Plainfield, Township of, Illinois
- 1763. Plainfield, Village of, Illinois
- 1764. Plano, City of, Illinois
- 1765. Pontiac, City of, Illinois
- 1766. Pontiac, Township of, Illinois
- 1767. Prospect Heights, City of, Illinois
- 1768. Proviso, Township of, Illinois
- 1769. Quincy, City of, Illinois
- 1770. Quincy, Township of, Illinois
- 1771. Randolph, County of, Illinois

- 1772. Rantoul, Township of, Illinois
- 1773. Rantoul, Village of, Illinois
- 1774. Rich, Township of, Illinois
- 1775. Richland, County of, Illinois
- 1776. Richton Park, Village of, Illinois
- 1777. River Forest, Township of, Illinois
- 1778. River Forest, Village of, Illinois
- 1779. Riverdale, Village of, Illinois
- 1780. Riverside, Township of, Illinois
- 1781. Rock Island, City of, Illinois
- 1782. Rock Island, County of, Illinois
- 1783. Rock Island, Township of, Illinois
- 1784. Rockford, City of, Illinois
- 1785. Rockford, Township of, Illinois
- 1786. Rockton, Township of, Illinois
- 1787. Rolling Meadows, City of, Illinois
- 1788. Romeoville, Village of, Illinois
- 1789. Roscoe, Township of, Illinois
- 1790. Roscoe, Village of, Illinois
- 1791. Roselle, Village of, Illinois
- 1792. Round Lake Beach, Village of, Illinois
- 1793. Round Lake, Village of, Illinois
- 1794. Rutland, Township of, Illinois
- 1795. Saline, County of, Illinois
- 1796. Sangamon, County of, Illinois
- 1797. Sauk Village, Village of, Illinois
- 1798. Schaumburg, Township of, Illinois
- 1799. Schaumburg, Village of, Illinois
- 1800. Schiller Park, Village of, Illinois
- 1801. Shelby, County of, Illinois
- 1802. Shields, Township of, Illinois
- 1803. Shiloh Valley, Township of, Illinois
- 1804. Shiloh, Village of, Illinois
- 1805. Shorewood, Village of, Illinois
- 1806. Skokie, Village of, Illinois
- 1807. South Elgin, Village of, Illinois
- 1808. South Holland, Village of, Illinois
- 1809. South Moline, Township of, Illinois
- 1810. South Rock Island, Township of, Illinois
- 1811. Springfield, City of, Illinois
- 1812. St. Charles, City of, Illinois
- 1813. St. Charles, Township of, Illinois
- 1814. St. Clair, County of, Illinois
- 1815. St. Clair, Township of, Illinois
- 1816. Stephenson, County of, Illinois
- 1817. Sterling, City of, Illinois
- 1818. Sterling, Township of, Illinois
- 1819. Stickney, Township of, Illinois
- 1820. Streamwood, Village of, Illinois
- 1821. Streator, City of, Illinois
- 1822. Sugar Grove, Township of, Illinois
- 1823. Summit, Village of, Illinois
- 1824. Swansea, Village of, Illinois
- 1825. Sycamore, City of, Illinois
- 1826. Sycamore, Township of, Illinois
- 1827. Taylorville, City of, Illinois
- 1828. Taylorville, Township of, Illinois
- 1829. Tazewell, County of, Illinois
- 1830. Thornton, Township of, Illinois
- 1831. Tinley Park, Village of, Illinois
- 1832. Troy, City of, Illinois
- 1833. Troy, Township of, Illinois
- 1834. Union, County of, Illinois
- 1835. Urbana, City of, Illinois
- 1836. Vermilion, County of, Illinois
- 1837. Vernon Hills, Village of, Illinois
- 1838. Vernon, Township of, Illinois
- 1839. Villa Park, Village of, Illinois
- 1840. Wabash, County of, Illinois
- 1841. Warren, County of, Illinois
- 1842. Warren, Township of, Illinois
- 1843. Warrenville, City of, Illinois
- 1844. Washington, City of, Illinois
- 1845. Washington, County of, Illinois
- 1846. Washington, Township of, Illinois
- 1847. Waterloo, City of, Illinois
- 1848. Wauconda, Township of, Illinois
- 1849. Wauconda, Village of, Illinois
- 1850. Waukegan, City of, Illinois
- 1851. Waukegan, Township of, Illinois
- 1852. Wayne, County of, Illinois
- 1853. Wayne, Township of, Illinois
- 1854. West Chicago, City of, Illinois
- 1855. West Deerfield, Township of, Illinois
- 1856. Westchester, Village of, Illinois
- 1857. Western Springs, Village of, Illinois
- 1858. Westmont, Village of, Illinois
- 1859. Wheatland, Township of, Illinois
- 1860. Wheaton, City of, Illinois
- 1861. Wheeling, Township of, Illinois

- 1862. Wheeling, Village of, Illinois
- 1863. White, County of, Illinois
- 1864. Whiteside, County of, Illinois
- 1865. Will, County of, Illinois
- 1866. Williamson, County of, Illinois
- 1867. Wilmette, Village of, Illinois
- 1868. Winfield, Township of, Illinois
- 1869. Winnebago, County of, Illinois
- 1870. Winnetka, Village of, Illinois
- 1871. Wood Dale, City of, Illinois
- 1872. Wood River, City of, Illinois
- 1873. Wood River, Township of, Illinois
- 1874. Woodford, County of, Illinois
- 1875. Woodridge, Village of, Illinois
- 1876. Woodside, Township of, Illinois
- 1877. Woodstock, City of, Illinois
- 1878. Worth, Township of, Illinois
- 1879. Worth, Village of, Illinois
- 1880. York, Township of, Illinois
- 1881. Yorkville, City of, Illinois
- 1882. Zion, City of, Illinois
- 1883. Zion, Township of, Illinois
- 1884. Aboite, Township of, Indiana
- 1885. Adams, County of, Indiana
- 1886. Adams, Township of, Indiana
- 1887. Addison, Township of, Indiana
- 1888. Allen, County of, Indiana
- 1889. Anderson, City of, Indiana
- 1890. Anderson, Township of, Indiana
- 1891. Auburn, City of, Indiana
- 1892. Avon, Town of, Indiana
- 1893. Bainbridge, Township of, Indiana
- 1894. Bartholomew, County of, Indiana
- 1895. Baugo, Township of, Indiana
- 1896. Bedford, City of, Indiana
- 1897. Beech Grove, City of, Indiana
- 1898. Blackford, County of, Indiana
- 1899. Bloomington, City of, Indiana
- 1900. Bloomington, Township of, Indiana
- 1901. Bluffton, City of, Indiana
- 1902. Boon, Township of, Indiana
- 1903. Boone, County of, Indiana
- 1904. Brown, County of, Indiana
- 1905. Brown, Township of, Indiana
- 1906. Brownsburg, Town of, Indiana
- 1907. Calumet, Township of, Indiana
- 1908. Carmel, City of, Indiana
- 1909. Carroll, County of, Indiana
- 1910. Cass, County of, Indiana
- 1911. Cedar Creek, Township of, Indiana
- 1912. Cedar Lake, Town of, Indiana
- 1913. Center, Township of, Indiana
- 1914. Centre, Township of, Indiana
- 1915. Charlestown, Township of, Indiana
- 1916. Chesterton, Town of, Indiana
- 1917. Clark, County of, Indiana
- 1918. Clarksville, Town of, Indiana
- 1919. Clay, County of, Indiana
- 1920. Clay, Township of, Indiana
- 1921. Cleveland, Township of, Indiana
- 1922. Clinton, County of, Indiana
- 1923. Columbia, Township of, Indiana
- 1924. Columbus, City of, Indiana
- 1925. Columbus, Township of, Indiana
- 1926. Concord, Township of, Indiana
- 1927. Connersville, City of, Indiana
- 1928. Connersville, Township of, Indiana
- 1929. Coolspring, Township of, Indiana
- 1930. Crawford, County of, Indiana
- 1931. Crawfordsville, City of, Indiana
- 1932. Crown Point, City of, Indiana
- 1933. Danville, Town of, Indiana
- 1934. Daviess, County of, Indiana
- 1935. Dearborn, County of, Indiana
- 1936. Decatur, County of, Indiana
- 1937. Decatur, Township of, Indiana
- 1938. DeKalb, County of, Indiana
- 1939. Delaware, County of, Indiana
- 1940. Delaware, Township of, Indiana
- 1941. Dubois, County of, Indiana
- 1942. Dyer, Town of, Indiana
- 1943. East Chicago, City of, Indiana
- 1944. Eel, Township of, Indiana
- 1945. Elkhart, City of, Indiana
- 1946. Elkhart, County of, Indiana
- 1947. Elkhart, Township of, Indiana
- 1948. Evansville, City of, Indiana
- 1949. Fairfield, Township of, Indiana
- 1950. Fall Creek, Township of, Indiana
- 1951. Fayette, County of, Indiana
- 1952. Fishers, City of, Indiana
- 1953. Floyd, County of, Indiana

- 1954. Fort Wayne, City of, Indiana
- 1955. Fountain, County of, Indiana
- 1956. Frankfort, City of, Indiana
- 1957. Franklin, City of, Indiana
- 1958. Franklin, County of, Indiana
- 1959. Franklin, Township of, Indiana
- 1960. Fulton, County of, Indiana
- 1961. Gary, City of, Indiana
- 1962. Georgetown, Township of, Indiana
- 1963. Gibson, County of, Indiana
- 1964. Goshen, City of, Indiana
- 1965. Grant, County of, Indiana
- 1966. Greencastle, City of, Indiana
- 1967. Greencastle, Township of, Indiana
- 1968. Greene, County of, Indiana
- 1969. Greenfield, City of, Indiana
- 1970. Greensburg, City of, Indiana
- 1971. Greenwood, City of, Indiana
- 1972. Griffith, Town of, Indiana
- 1973. Guilford, Township of, Indiana
- 1974. Hamilton, County of, Indiana
- 1975. Hammond, City of, Indiana
- 1976. Hancock, County of, Indiana
- 1977. Hanover, Township of, Indiana
- 1978. Harris, Township of, Indiana
- 1979. Harrison, County of, Indiana
- 1980. Harrison, Township of, Indiana
- 1981. Hendricks, County of, Indiana
- 1982. Henry, County of, Indiana
- 1983. Henry, Township of, Indiana
- 1984. Highland, Town of, Indiana
- 1985. Hobart, City of, Indiana
- 1986. Hobart, Township of, Indiana
- 1987. Honey Creek, Township of, Indiana
- 1988. Howard, County of, Indiana
- 1989. Huntington, City of, Indiana
- 1990. Huntington, County of, Indiana
- 1991. Huntington, Township of, Indiana
- 1992. Jackson, County of, Indiana
- 1993. Jackson, Township of, Indiana
- 1994. Jasper, City of, Indiana
- 1995. Jasper, County of, Indiana
- 1996. Jay, County of, Indiana
- 1997. Jefferson, County of, Indiana
- 1998. Jefferson, Township of, Indiana
- 1999. Jeffersonville, City of, Indiana
- 2000. Jeffersonville, Township of, Indiana
- 2001. Jennings, County of, Indiana
- 2002. Johnson, County of, Indiana
- 2003. Keener, Township of, Indiana
- 2004. Knight, Township of, Indiana
- 2005. Knox, County of, Indiana
- 2006. Kokomo, City of, Indiana
- 2007. Kosciusko, County of, Indiana
- 2008. La Porte, City of, Indiana
- 2009. Lafayette, City of, Indiana
- 2010. LaGrange, County of, Indiana
- 2011. Lake, County of, Indiana
- 2012. Lake Station, City of, Indiana
- 2013. LaPorte, County of, Indiana
- 2014. Lawrence, City of, Indiana
- 2015. Lawrence, County of, Indiana
- 2016. Lawrence, Township of, Indiana
- 2017. Lawrenceburg, Township of, Indiana
- 2018. Lebanon, City of, Indiana
- 2019. Lincoln, Township of, Indiana
- 2020. Logansport, City of, Indiana
- 2021. Lost Creek, Township of, Indiana
- 2022. Madison, City of, Indiana
- 2023. Madison, County of, Indiana
- 2024. Madison, Township of, Indiana
- 2025. Marion, City of, Indiana
- 2026. Marion, County of/ Indianapolis, City of, Indiana
- 2027. Marshall, County of, Indiana
- 2028. Martin, County of, Indiana
- 2029. Martinsville, City of, Indiana
- 2030. Merrillville, Town of, Indiana
- 2031. Miami, County of, Indiana
- 2032. Michigan City, City of, Indiana
- 2033. Michigan, Township of, Indiana
- 2034. Mill, Township of, Indiana
- 2035. Mishawaka, City of, Indiana
- 2036. Monroe, County of, Indiana
- 2037. Montgomery, County of, Indiana
- 2038. Morgan, County of, Indiana
- 2039. Muncie, City of, Indiana
- 2040. Munster, Town of, Indiana
- 2041. New Albany, City of, Indiana
- 2042. New Albany, Township of, Indiana
- 2043. New Castle, City of, Indiana
- 2044. New Haven, City of, Indiana

- 2045. Newton, County of, Indiana
- 2046. Noble, County of, Indiana
- 2047. Noble, Township of, Indiana
- 2048. Noblesville, City of, Indiana
- 2049. Noblesville, Township of, Indiana
- 2050. North, Township of, Indiana
- 2051. Ohio, Township of, Indiana
- 2052. Orange, County of, Indiana
- 2053. Osolo, Township of, Indiana
- 2054. Owen, County of, Indiana
- 2055. Parke, County of, Indiana
- 2056. Patoka, Township of, Indiana
- 2057. Penn, Township of, Indiana
- 2058. Perry, County of, Indiana
- 2059. Perry, Township of, Indiana
- 2060. Peru, City of, Indiana
- 2061. Peru, Township of, Indiana
- 2062. Pigeon, Township of, Indiana
- 2063. Pike, County of, Indiana
- 2064. Pike, Township of, Indiana
- 2065. Pipe Creek, Township of, Indiana
- 2066. Plainfield, Town of, Indiana
- 2067. Pleasant, Township of, Indiana
- 2068. Portage, City of, Indiana
- 2069. Portage, Township of, Indiana
- 2070. Porter, County of, Indiana
- 2071. Posey, County of, Indiana
- 2072. Pulaski, County of, Indiana
- 2073. Putnam, County of, Indiana
- 2074. Randolph, County of, Indiana
- 2075. Richland, Township of, Indiana
- 2076. Richmond, City of, Indiana
- 2077. Ripley, County of, Indiana
- 2078. Ross, Township of, Indiana
- 2079. Rush, County of, Indiana
- 2080. Schererville, Town of, Indiana
- 2081. Scott, County of, Indiana
- 2082. Seymour, City of, Indiana
- 2083. Shawswick, Township of, Indiana
- 2084. Shelby, County of, Indiana
- 2085. Shelbyville, City of, Indiana
- 2086. Silver Creek, Township of, Indiana
- 2087. South Bend, City of, Indiana
- 2088. Speedway, Town of, Indiana
- 2089. Spencer, County of, Indiana
- 2090. St. John, Town of, Indiana
- 2091. St. John, Township of, Indiana
- 2092. St. Joseph, County of, Indiana
- 2093. St. Joseph, Township of, Indiana
- 2094. Starke, County of, Indiana
- 2095. Steuben, County of, Indiana
- 2096. Sugar Creek, Township of, Indiana
- 2097. Sullivan, County of, Indiana
- 2098. Switzerland, County of, Indiana
- 2099. Terre Haute, City of, Indiana
- 2100. Tippecanoe, County of, Indiana
- 2101. Tipton, County of, Indiana
- 2102. Troy, Township of, Indiana
- 2103. Union, Township of, Indiana
- 2104. Valparaiso, City of, Indiana
- 2105. Van Buren, Township of, Indiana
- 2106. Vanderburgh, County of, Indiana
- 2107. Vermillion, County of, Indiana
- 2108. Vernon, Township of, Indiana
- 2109. Vigo, County of, Indiana
- 2110. Vincennes, City of, Indiana
- 2111. Vincennes, Township of, Indiana
- 2112. Wabash, County of, Indiana
- 2113. Wabash, Township of, Indiana
- 2114. Warren, Township of, Indiana
- 2115. Warrick, County of, Indiana
- 2116. Warsaw, City of, Indiana
- 2117. Washington, City of, Indiana
- 2118. Washington, County of, Indiana
- 2119. Washington, Township of, Indiana
- 2120. Wayne, County of, Indiana
- 2121. Wayne, Township of, Indiana
- 2122. Wea, Township of, Indiana
- 2123. Wells, County of, Indiana
- 2124. West Lafayette, City of, Indiana
- 2125. Westchester, Township of, Indiana
- 2126. Westfield, City of, Indiana
- 2127. White, County of, Indiana
- 2128. White River, Township of, Indiana
- 2129. Whitley, County of, Indiana
- 2130. Winfield, Township of, Indiana
- 2131. Yorktown, Town of, Indiana
- 2132. Zionsville, Town of, Indiana
- 2133. Allamakee, County of, Iowa
- 2134. Altoona, City of, Iowa
- 2135. Ames, City of, Iowa
- 2136. Ankeny, City of, Iowa

- 2137. Appanoose, County of, Iowa
- 2138. Benton, County of, Iowa
- 2139. Bettendorf, City of, Iowa
- 2140. Black Hawk, County of, Iowa
- 2141. Boone, City of, Iowa
- 2142. Boone, County of, Iowa
- 2143. Bremer, County of, Iowa
- 2144. Buchanan, County of, Iowa
- 2145. Buena Vista, County of, Iowa
- 2146. Burlington, City of, Iowa
- 2147. Butler, County of, Iowa
- 2148. Carroll, County of, Iowa
- 2149. Cass, County of, Iowa
- 2150. Cedar, County of, Iowa
- 2151. Cedar Falls, City of, Iowa
- 2152. Cedar Rapids, City of, Iowa
- 2153. Cerro Gordo, County of, Iowa
- 2154. Cherokee, County of, Iowa
- 2155. Chickasaw, County of, Iowa
- 2156. Clay, County of, Iowa
- 2157. Clayton, County of, Iowa
- 2158. Clinton, City of, Iowa
- 2159. Clinton, County of, Iowa
- 2160. Clive, City of, Iowa
- 2161. Coralville, City of, Iowa
- 2162. Council Bluffs, City of, Iowa
- 2163. Crawford, County of, Iowa
- 2164. Dallas, County of, Iowa
- 2165. Davenport, City of, Iowa
- 2166. Delaware, County of, Iowa
- 2167. Des Moines, City of, Iowa
- 2168. Des Moines, County of, Iowa
- 2169. Dickinson, County of, Iowa
- 2170. Dubuque, City of, Iowa
- 2171. Dubuque, County of, Iowa
- 2172. Fairfield, City of, Iowa
- 2173. Fayette, County of, Iowa
- 2174. Floyd, County of, Iowa
- 2175. Fort Dodge, City of, Iowa
- 2176. Fort Madison, City of, Iowa
- 2177. Franklin, County of, Iowa
- 2178. Grimes, City of, Iowa
- 2179. Grundy, County of, Iowa
- 2180. Guthrie, County of, Iowa
- 2181. Hamilton, County of, Iowa
- 2182. Hancock, County of, Iowa
- 2183. Hardin, County of, Iowa
- 2184. Harrison, County of, Iowa
- 2185. Henry, County of, Iowa
- 2186. Indianola, City of, Iowa
- 2187. Iowa City, City of, Iowa
- 2188. Iowa, County of, Iowa
- 2189. Jackson, County of, Iowa
- 2190. Jasper, County of, Iowa
- 2191. Jefferson, County of, Iowa
- 2192. Johnson, County of, Iowa
- 2193. Johnston, City of, Iowa
- 2194. Jones, County of, Iowa
- 2195. Keokuk, City of, Iowa
- 2196. Keokuk, County of, Iowa
- 2197. Kossuth, County of, Iowa
- 2198. Le Mars, City of, Iowa
- 2199. Lee, County of, Iowa
- 2200. Linn, County of, Iowa
- 2201. Louisa, County of, Iowa
- 2202. Lyon, County of, Iowa
- 2203. Madison, County of, Iowa
- 2204. Mahaska, County of, Iowa
- 2205. Marion, City of, Iowa
- 2206. Marion, County of, Iowa
- 2207. Marshall, County of, Iowa
- 2208. Marshalltown, City of, Iowa
- 2209. Mason City, City of, Iowa
- 2210. Mills, County of, Iowa
- 2211. Mitchell, County of, Iowa
- 2212. Muscatine, City of, Iowa
- 2213. Muscatine, County of, Iowa
- 2214. Newton, City of, Iowa
- 2215. North Liberty, City of, Iowa
- 2216. Norwalk, City of, Iowa
- 2217. O'Brien, County of, Iowa
- 2218. Oskaloosa, City of, Iowa
- 2219. Ottumwa, City of, Iowa
- 2220. Page, County of, Iowa
- 2221. Pella, City of, Iowa
- 2222. Pleasant Hill, City of, Iowa
- 2223. Plymouth, County of, Iowa
- 2224. Polk, County of, Iowa
- 2225. Pottawattamie, County of, Iowa
- 2226. Poweshiek, County of, Iowa
- 2227. Scott, County of, Iowa
- 2228. Shelby, County of, Iowa

- 2229. Sioux City, City of, Iowa
- 2230. Sioux, County of, Iowa
- 2231. Spencer, City of, Iowa
- 2232. Storm Lake, City of, Iowa
- 2233. Story, County of, Iowa
- 2234. Tama, County of, Iowa
- 2235. Union, County of, Iowa
- 2236. Urbandale, City of, Iowa
- 2237. Wapello, County of, Iowa
- 2238. Warren, County of, Iowa
- 2239. Washington, County of, Iowa
- 2240. Waterloo, City of, Iowa
- 2241. Waukee, City of, Iowa
- 2242. Waverly, City of, Iowa
- 2243. Webster, County of, Iowa
- 2244. West Des Moines, City of, Iowa
- 2245. Winnebago, County of, Iowa
- 2246. Winneshiek, County of, Iowa
- 2247. Woodbury, County of, Iowa
- 2248. Wright, County of, Iowa
- 2249. Allen, County of, Kansas
- 2250. Andover, City of, Kansas
- 2251. Arkansas City, City of, Kansas
- 2252. Atchison, City of, Kansas
- 2253. Atchison, County of, Kansas
- 2254. Barton, County of, Kansas
- 2255. Bourbon, County of, Kansas
- 2256. Bruno, Township of, Kansas
- 2257. Butler, County of, Kansas
- 2258. Cherokee, County of, Kansas
- 2259. Cowley, County of, Kansas
- 2260. Crawford, County of, Kansas
- 2261. Derby, City of, Kansas
- 2262. Dickinson, County of, Kansas
- 2263. Dodge City, City of, Kansas
- 2264. Douglas, County of, Kansas
- 2265. El Dorado, City of, Kansas
- 2266. Ellis, County of, Kansas
- 2267. Emporia, City of, Kansas
- 2268. Fairmount, Township of, Kansas
- 2269. Finney, County of, Kansas
- 2270. Ford, County of, Kansas
- 2271. Franklin, County of, Kansas
- 2272. Garden City, City of, Kansas
- 2273. Gardner, City of, Kansas
- 2274. Geary, County of, Kansas
- 2275. Great Bend, City of, Kansas
- 2276. Harvey, County of, Kansas
- 2277. Hays, City of, Kansas
- 2278. Haysville, City of, Kansas
- 2279. Haysville, City of, Kansas
- 2280. Hutchinson, City of, Kansas
- 2281. Jackson, County of, Kansas
- 2282. Jefferson, County of, Kansas
- 2283. Johnson, County of, Kansas
- 2284. Junction City, City of, Kansas
- 2285. Kansas City, City of, Kansas
- 2286. Kansas City, City of, Kansas
- 2287. Labette, County of, Kansas
- 2288. Lansing, City of, Kansas
- 2289. Lawrence, City of, Kansas
- 2290. Lawrence, City of, Kansas
- 2291. Leavenworth, City of, Kansas
- 2292. Leavenworth, County of, Kansas
- 2293. Leawood, City of, Kansas
- 2294. Lenexa, City of, Kansas
- 2295. Liberal, City of, Kansas
- 2296. Lyon, County of, Kansas
- 2297. Madison, Township of, Kansas
- 2298. Manhattan, City of, Kansas
- 2299. Marion, County of, Kansas
- 2300. McPherson, City of, Kansas
- 2301. McPherson, County of, Kansas
- 2302. Merriam, City of, Kansas
- 2303. Miami, County of, Kansas
- 2304. Montgomery, County of, Kansas
- 2305. Nemaha, County of, Kansas
- 2306. Neosho, County of, Kansas
- 2307. Newton, City of, Kansas
- 2308. Olathe, City of, Kansas
- 2309. Osage, County of, Kansas
- 2310. Ottawa, City of, Kansas
- 2311. Overland Park, City of, Kansas
- 2312. Pittsburg, City of, Kansas
- 2313. Pottawatomie, County of, Kansas
- 2314. Prairie, Village of, City of, Kansas
- 2315. Reno, County of, Kansas
- 2316. Riley, County of, Kansas
- 2317. Riverside, Township of, Kansas
- 2318. Rockford, Township of, Kansas
- 2319. Salina, City of, Kansas
- 2320. Saline, County of, Kansas

- 2321. Sedgwick, County of, Kansas
- 2322. Seward, County of, Kansas
- 2323. Shawnee, City of, Kansas
- 2324. Shawnee, County of, Kansas
- 2325. Soldier, Township of, Kansas
- 2326. Sumner, County of, Kansas
- 2327. Topeka, City of, Kansas
- 2328. Wichita, City of, Kansas
- 2329. Winfield, City of, Kansas
- 2330. Wyandotte, County of, Kansas
- 2331. Adair, County of, Kentucky
- 2332. Allen, County of, Kentucky
- 2333. Anderson, County of, Kentucky
- 2334. Ashland, City of, Kentucky
- 2335. Bardstown, City of, Kentucky
- 2336. Barren, County of, Kentucky
- 2337. Bath, County of, Kentucky
- 2338. Bell, County of, Kentucky
- 2339. Berea, City of, Kentucky
- 2340. Boone, County of, Kentucky
- 2341. Bourbon, County of, Kentucky
- 2342. Bowling Green, City of, Kentucky
- 2343. Boyd, County of, Kentucky
- 2344. Boyle, County of, Kentucky
- 2345. Breathitt, County of, Kentucky
- 2346. Breckinridge, County of, Kentucky
- 2347. Bullitt, County of, Kentucky
- 2348. Butler, County of, Kentucky
- 2349. Caldwell, County of, Kentucky
- 2350. Calloway, County of, Kentucky
- 2351. Campbell, County of, Kentucky
- 2352. Campbellsville, City of, Kentucky
- 2353. Carroll, County of, Kentucky
- 2354. Carter, County of, Kentucky
- 2355. Casey, County of, Kentucky
- 2356. Christian, County of, Kentucky
- 2357. Clark, County of, Kentucky
- 2358. Clay, County of, Kentucky
- 2359. Clinton, County of, Kentucky
- 2360. Covington, City of, Kentucky
- 2361. Danville, City of, Kentucky
- 2362. Daviess, County of, Kentucky
- 2363. Edmonson, County of, Kentucky
- 2364. Elizabethtown, City of, Kentucky
- 2365. Erlanger, City of, Kentucky
- 2366. Estill, County of, Kentucky
- 2367. Fleming, County of, Kentucky
- 2368. Florence, City of, Kentucky
- 2369. Floyd, County of, Kentucky
- 2370. Fort Thomas, City of, Kentucky
- 2371. Frankfort, City of, Kentucky
- 2372. Franklin, County of, Kentucky
- 2373. Garrard, County of, Kentucky
- 2374. Georgetown, City of, Kentucky
- 2375. Glasgow, City of, Kentucky
- 2376. Grant, County of, Kentucky
- 2377. Graves, County of, Kentucky
- 2378. Grayson, County of, Kentucky
- 2379. Green, County of, Kentucky
- 2380. Greenup, County of, Kentucky
- 2381. Hardin, County of, Kentucky
- 2382. Harlan, County of, Kentucky
- 2383. Harrison, County of, Kentucky
- 2384. Hart, County of, Kentucky
- 2385. Henderson, City of, Kentucky
- 2386. Henderson, County of, Kentucky
- 2387. Henry, County of, Kentucky
- 2388. Hopkins, County of, Kentucky
- 2389. Hopkinsville, City of, Kentucky
- 2390. Independence, City of, Kentucky
- 2391. Jackson, County of, Kentucky
- 2392. Jeffersontown, City of, Kentucky
- 2393. Jessamine, County of, Kentucky
- 2394. Johnson, County of, Kentucky
- 2395. Kenton, County of, Kentucky
- 2396. Knott, County of, Kentucky
- 2397. Knox, County of, Kentucky
- 2398. Larue, County of, Kentucky
- 2399. Laurel, County of, Kentucky
- 2400. Lawrence, County of, Kentucky
- 2401. Lawrenceburg, City of, Kentucky
- 2402. Letcher, County of, Kentucky
- 2403. Lewis, County of, Kentucky
- 2404. Lexington-Fayette, Urban County of, Kentucky
- 2405. Lincoln, County of, Kentucky
- 2406. Logan, County of, Kentucky
- 2407. Louisville/Jefferson, County Metro of, Kentucky
- 2408. Lyndon, City of, Kentucky
- 2409. Madison, County of, Kentucky
- 2410. Madisonville, City of, Kentucky



- 2411. Magoffin, County of, Kentucky
- 2412. Marion, County of, Kentucky
- 2413. Marshall, County of, Kentucky
- 2414. Martin, County of, Kentucky
- 2415. Mason, County of, Kentucky
- 2416. McCracken, County of, Kentucky
- 2417. McCreary, County of, Kentucky
- 2418. Meade, County of, Kentucky
- 2419. Mercer, County of, Kentucky
- 2420. Metcalfe, County of, Kentucky
- 2421. Monroe, County of, Kentucky
- 2422. Montgomery, County of, Kentucky
- 2423. Morgan, County of, Kentucky
- 2424. Mount Washington, City of,  
Kentucky
- 2425. Muhlenberg, County of, Kentucky
- 2426. Murray, City of, Kentucky
- 2427. Nelson, County of, Kentucky
- 2428. Newport, City of, Kentucky
- 2429. Nicholasville, City of, Kentucky
- 2430. Ohio, County of, Kentucky
- 2431. Oldham, County of, Kentucky
- 2432. Owen, County of, Kentucky
- 2433. Owensboro, City of, Kentucky
- 2434. Paducah, City of, Kentucky
- 2435. Pendleton, County of, Kentucky
- 2436. Perry, County of, Kentucky
- 2437. Pike, County of, Kentucky
- 2438. Powell, County of, Kentucky
- 2439. Pulaski, County of, Kentucky
- 2440. Radcliff, City of, Kentucky
- 2441. Richmond, City of, Kentucky
- 2442. Rockcastle, County of, Kentucky
- 2443. Rowan, County of, Kentucky
- 2444. Russell, County of, Kentucky
- 2445. Scott, County of, Kentucky
- 2446. Shelby, County of, Kentucky
- 2447. Shelbyville, City of, Kentucky
- 2448. Shepherdsville, City of, Kentucky
- 2449. Shively, City of, Kentucky
- 2450. Simpson, County of, Kentucky
- 2451. Somerset, City of, Kentucky
- 2452. Spencer, County of, Kentucky
- 2453. St. Matthews, City of, Kentucky
- 2454. Taylor, County of, Kentucky
- 2455. Todd, County of, Kentucky
- 2456. Trigg, County of, Kentucky
- 2457. Union, County of, Kentucky
- 2458. Warren, County of, Kentucky
- 2459. Washington, County of, Kentucky
- 2460. Wayne, County of, Kentucky
- 2461. Webster, County of, Kentucky
- 2462. Whitley, County of, Kentucky
- 2463. Winchester, City of, Kentucky
- 2464. Woodford, County of, Kentucky
- 2465. Morgan, County of, Kentucky  
Louisiana
- 2466. Abbeville, City of, Louisiana
- 2467. Acadia, Parish of, Louisiana
- 2468. Alexandria, City of, Louisiana
- 2469. Allen, Parish of, Louisiana
- 2470. Ascension, Parish of, Louisiana
- 2471. Assumption, Parish of, Louisiana
- 2472. Avoyelles, Parish of, Louisiana
- 2473. Baker, City of, Louisiana
- 2474. Bastrop, City of, Louisiana
- 2475. Baton Rouge, City of, Louisiana
- 2476. Beauregard, Parish of, Louisiana
- 2477. Bienville, Parish of, Louisiana
- 2478. Bogalusa, City of, Louisiana
- 2479. Bossier City, City of, Louisiana
- 2480. Bossier, Parish of, Louisiana
- 2481. Broussard, City of, Louisiana
- 2482. Caddo, Parish of, Louisiana
- 2483. Calcasieu, Parish of, Louisiana
- 2484. Central, City of, Louisiana
- 2485. Claiborne, Parish of, Louisiana
- 2486. Concordia, Parish of, Louisiana
- 2487. Covington, City of, Louisiana
- 2488. Crowley, City of, Louisiana
- 2489. De Soto, Parish of, Louisiana
- 2490. DeRidder, City of, Louisiana
- 2491. East Baton Rouge, Parish of,  
Louisiana
- 2492. East Feliciana, Parish of, Louisiana
- 2493. Evangeline, Parish of, Louisiana
- 2494. Franklin, Parish of, Louisiana
- 2495. Gonzales, City of, Louisiana
- 2496. Grant, Parish of, Louisiana
- 2497. Gretna, City of, Louisiana
- 2498. Hammond, City of, Louisiana
- 2499. Iberia, Parish of, Louisiana

- 2500. Iberville, Parish of, Louisiana
- 2501. Jackson, Parish of, Louisiana
- 2502. Jefferson Davis, Parish of, Louisiana
- 2503. Jefferson, Parish of, Louisiana
- 2504. Kenner, City of, Louisiana
- 2505. Lafayette, City of, Louisiana
- 2506. Lafayette, Parish of, Louisiana
- 2507. Lafourche, Parish of, Louisiana
- 2508. Lake Charles, City of, Louisiana
- 2509. LaSalle, Parish of, Louisiana
- 2510. Lincoln, Parish of, Louisiana
- 2511. Livingston, Parish of, Louisiana
- 2512. Madison, Parish of, Louisiana
- 2513. Mandeville, City of, Louisiana
- 2514. Minden, City of, Louisiana
- 2515. Monroe, City of, Louisiana
- 2516. Morehouse, Parish of, Louisiana
- 2517. Morgan City, City of, Louisiana
- 2518. Natchitoches, City of, Louisiana
- 2519. Natchitoches, Parish of, Louisiana
- 2520. New Iberia, City of, Louisiana
- 2521. New Orleans, City of, Louisiana
- 2522. Orleans, Parish of, Louisiana
- 2523. Opelousas, City of, Louisiana
- 2524. Ouachita, Parish of, Louisiana
- 2525. Pineville, City of, Louisiana
- 2526. Plaquemines, Parish of, Louisiana
- 2527. Pointe Coupee, Parish of, Louisiana
- 2528. Rapides, Parish of, Louisiana
- 2529. Richland, Parish of, Louisiana
- 2530. Ruston, City of, Louisiana
- 2531. Sabine, Parish of, Louisiana
- 2532. Shreveport, City of, Louisiana
- 2533. Slidell, City of, Louisiana
- 2534. St. Bernard, Parish of, Louisiana
- 2535. St. Charles, Parish of, Louisiana
- 2536. St. Helena, Parish of, Louisiana
- 2537. St. James, Parish of, Louisiana
- 2538. St. John the Baptist, Parish of,  
Louisiana
- 2539. St. Landry, Parish of, Louisiana
- 2540. St. Martin, Parish of, Louisiana
- 2541. St. Mary, Parish of, Louisiana
- 2542. St. Tammany, Parish of, Louisiana
- 2543. Sulphur, City of, Louisiana
- 2544. Tangipahoa, Parish of, Louisiana
- 2545. Terrebonne, Parish of/ Houma, City  
of, Louisiana
- 2546. Thibodaux, City of, Louisiana
- 2547. Union, Parish of, Louisiana
- 2548. Vermilion, Parish of, Louisiana
- 2549. Vernon, Parish of, Louisiana
- 2550. Washington, Parish of, Louisiana
- 2551. Webster, Parish of, Louisiana
- 2552. West Baton Rouge, Parish of,  
Louisiana
- 2553. West Carroll, Parish of, Louisiana
- 2554. West Feliciana, Parish of, Louisiana
- 2555. West Monroe, City of, Louisiana
- 2556. Winn, Parish of, Louisiana
- 2557. Youngsville, City of, Louisiana
- 2558. Zachary, City of, Louisiana
- 2559. Androscoggin, County of, Maine
- 2560. Aroostook, County of, Maine
- 2561. Auburn, City of, Maine
- 2562. Augusta, City of, Maine
- 2563. Bangor, City of, Maine
- 2564. Biddeford, City of, Maine
- 2565. Brunswick, Town of, Maine
- 2566. Cumberland, County of, Maine
- 2567. Falmouth, Town of, Maine
- 2568. Franklin, County of, Maine
- 2569. Gorham, Town of, Maine
- 2570. Hancock, County of, Maine
- 2571. Kennebec, County of, Maine
- 2572. Kennebunk, Town of, Maine
- 2573. Knox, County of, Maine
- 2574. Lewiston, City of, Maine
- 2575. Lincoln, County of, Maine
- 2576. Orono, Town of, Maine
- 2577. Oxford, County of, Maine
- 2578. Penobscot, County of, Maine
- 2579. Piscataquis, County of, Maine
- 2580. Portland, City of, Maine
- 2581. Saco, City of, Maine
- 2582. Sagadahoc, County of, Maine
- 2583. Sanford, City of, Maine
- 2584. Scarborough, Town of, Maine
- 2585. Somerset, County of, Maine
- 2586. South Portland, City of, Maine
- 2587. Standish, Town of, Maine
- 2588. Waldo, County of, Maine

- 2589. Washington, County of, Maine
- 2590. Waterville, City of, Maine
- 2591. Wells, Town of, Maine
- 2592. Westbrook, City of, Maine
- 2593. Windham, Town of, Maine
- 2594. York, County of, Maine
- 2595. York, Town of, Maine
- 2596. Aberdeen, City of, Maryland
- 2597. Allegany, County of, Maryland
- 2598. Annapolis, City of, Maryland
- 2599. Anne Arundel, County of, Maryland
- 2600. Baltimore, City of, Maryland
- 2601. Baltimore, County of, Maryland
- 2602. Bel Air, Town of, Maryland
- 2603. Bowie, City of, Maryland
- 2604. Calvert, County of, Maryland
- 2605. Cambridge, City of, Maryland
- 2606. Caroline, County of, Maryland
- 2607. Carroll, County of, Maryland
- 2608. Cecil, County of, Maryland
- 2609. Charles, County of, Maryland
- 2610. College Park, City of, Maryland
- 2611. Cumberland, City of, Maryland
- 2612. Dorchester, County of, Maryland
- 2613. Easton, Town of, Maryland
- 2614. Elkton, Town of, Maryland
- 2615. Frederick, City of, Maryland
- 2616. Frederick, County of, Maryland
- 2617. Gaithersburg, City of, Maryland
- 2618. Garrett, County of, Maryland
- 2619. Greenbelt, City of, Maryland
- 2620. Hagerstown, City of, Maryland
- 2621. Harford, County of, Maryland
- 2622. Havre de Grace, City of, Maryland
- 2623. Howard, County of, Maryland
- 2624. Hyattsville, City of, Maryland
- 2625. Kent, County of, Maryland
- 2626. Laurel, City of, Maryland
- 2627. Montgomery, County of, Maryland
- 2628. New Carrollton, City of, Maryland
- 2629. Prince George's, County of,  
Maryland
- 2630. Queen Anne's, County of, Maryland
- 2631. Rockville, City of, Maryland
- 2632. Salisbury, City of, Maryland
- 2633. Somerset, County of, Maryland
- 2634. St. Mary's, County of, Maryland
- 2635. Takoma Park, City of, Maryland
- 2636. Talbot, County of, Maryland
- 2637. Washington, County of, Maryland
- 2638. Westminster, City of, Maryland
- 2639. Wicomico, County of, Maryland
- 2640. Worcester, County of, Maryland
- 2641. Abington, Town of, Massachusetts
- 2642. Acton, Town of, Massachusetts
- 2643. Acushnet, Town of, Massachusetts
- 2644. Agawam, Town of/ City of,  
Massachusetts
- 2645. Amesbury, Town of/ City of,  
Massachusetts
- 2646. Amherst, Town of, Massachusetts
- 2647. Andover, Town of, Massachusetts
- 2648. Arlington, Town of, Massachusetts
- 2649. Ashland, Town of, Massachusetts
- 2650. Athol, Town of, Massachusetts
- 2651. Attleboro, City of, Massachusetts
- 2652. Auburn, Town of, Massachusetts
- 2653. Barnstable, County of,  
Massachusetts
- 2654. Barnstable, Town of/ City of,  
Massachusetts
- 2655. Bedford, Town of, Massachusetts
- 2656. Belchertown, Town of,  
Massachusetts
- 2657. Bellingham, Town of, Massachusetts
- 2658. Belmont, Town of, Massachusetts
- 2659. Beverly, City of, Massachusetts
- 2660. Billerica, Town of, Massachusetts
- 2661. Boston, City of, Massachusetts
- 2662. Bourne, Town of, Massachusetts
- 2663. Braintree, Town of/ City of,  
Massachusetts
- 2664. Bridgewater, Town of/ City of,  
Massachusetts
- 2665. Bristol, County of, Massachusetts
- 2666. Brockton, City of, Massachusetts
- 2667. Brookline, Town of, Massachusetts
- 2668. Burlington, Town of, Massachusetts
- 2669. Cambridge, City of, Massachusetts
- 2670. Canton, Town of, Massachusetts
- 2671. Carver, Town of, Massachusetts
- 2672. Charlton, Town of, Massachusetts

- 2673. Chelmsford, Town of, Massachusetts
- 2674. Chelsea, City of, Massachusetts
- 2675. Chicopee, City of, Massachusetts
- 2676. Clinton, Town of, Massachusetts
- 2677. Concord, Town of, Massachusetts
- 2678. Danvers, Town of, Massachusetts
- 2679. Dartmouth, Town of, Massachusetts
- 2680. Dedham, Town of, Massachusetts
- 2681. Dennis, Town of, Massachusetts
- 2682. Dracut, Town of, Massachusetts
- 2683. Dudley, Town of, Massachusetts
- 2684. Dukes, County of, Massachusetts
- 2685. Duxbury, Town of, Massachusetts
- 2686. East Bridgewater, Town of,  
Massachusetts
- 2687. East Longmeadow, Town of,  
Massachusetts
- 2688. Easthampton, Town of, City of,  
Massachusetts
- 2689. Easton, Town of, Massachusetts
- 2690. Everett, City of, Massachusetts
- 2691. Fairhaven, Town of, Massachusetts
- 2692. Fall River, City of, Massachusetts
- 2693. Falmouth, Town of, Massachusetts
- 2694. Fitchburg, City of, Massachusetts
- 2695. Foxborough, Town of,  
Massachusetts
- 2696. Framingham, City of, Massachusetts
- 2697. Franklin, Town of, City of,  
Massachusetts
- 2698. Gardner, City of, Massachusetts
- 2699. Gloucester, City of, Massachusetts
- 2700. Grafton, Town of, Massachusetts
- 2701. Greenfield, Town of, City of,  
Massachusetts
- 2702. Groton, Town of, Massachusetts
- 2703. Hanover, Town of, Massachusetts
- 2704. Hanson, Town of, Massachusetts
- 2705. Harwich, Town of, Massachusetts
- 2706. Haverhill, City of, Massachusetts
- 2707. Hingham, Town of, Massachusetts
- 2708. Holbrook, Town of, Massachusetts
- 2709. Holden, Town of, Massachusetts
- 2710. Holliston, Town of, Massachusetts
- 2711. Holyoke, City of, Massachusetts
- 2712. Hopkinton, Town of, Massachusetts
- 2713. Hudson, Town of, Massachusetts
- 2714. Hull, Town of, Massachusetts
- 2715. Ipswich, Town of, Massachusetts
- 2716. Kingston, Town of, Massachusetts
- 2717. Lakeville, Town of, Massachusetts
- 2718. Lawrence, City of, Massachusetts
- 2719. Leicester, Town of, Massachusetts
- 2720. Leominster, City of, Massachusetts
- 2721. Lexington, Town of, Massachusetts
- 2722. Littleton, Town of, Massachusetts
- 2723. Longmeadow, Town of,  
Massachusetts
- 2724. Lowell, City of, Massachusetts
- 2725. Ludlow, Town of, Massachusetts
- 2726. Lunenburg, Town of, Massachusetts
- 2727. Lynn, City of, Massachusetts
- 2728. Lynnfield, Town of, Massachusetts
- 2729. Malden, City of, Massachusetts
- 2730. Mansfield, Town of, Massachusetts
- 2731. Marblehead, Town of, Massachusetts
- 2732. Marlborough, City of, Massachusetts
- 2733. Marshfield, Town of, Massachusetts
- 2734. Mashpee, Town of, Massachusetts
- 2735. Maynard, Town of, Massachusetts
- 2736. Medfield, Town of, Massachusetts
- 2737. Medford, City of, Massachusetts
- 2738. Medway, Town of, Massachusetts
- 2739. Melrose, City of, Massachusetts
- 2740. Methuen, Town of, City of,  
Massachusetts
- 2741. Middleborough, Town of,  
Massachusetts
- 2742. Middleton, Town of, Massachusetts
- 2743. Milford, Town of, Massachusetts
- 2744. Millbury, Town of, Massachusetts
- 2745. Milton, Town of, Massachusetts
- 2746. Nantucket, Town of/ County of,  
Massachusetts
- 2747. Natick, Town of, Massachusetts
- 2748. Needham, Town of, Massachusetts
- 2749. New Bedford, City of, Massachusetts
- 2750. Newburyport, City of, Massachusetts
- 2751. Newton, City of, Massachusetts
- 2752. Norfolk, County of, Massachusetts
- 2753. Norfolk, Town of, Massachusetts
- 2754. North Adams, City of, Massachusetts

- 2755. North Andover, Town of, Massachusetts
- 2756. North Attleborough, Town of, Massachusetts
- 2757. North Reading, Town of, Massachusetts
- 2758. Northampton, City of, Massachusetts
- 2759. Northborough, Town of, Massachusetts
- 2760. Northbridge, Town of, Massachusetts
- 2761. Norton, Town of, Massachusetts
- 2762. Norwell, Town of, Massachusetts
- 2763. Norwood, Town of, Massachusetts
- 2764. Oxford, Town of, Massachusetts
- 2765. Palmer, Town of/ City of, Massachusetts
- 2766. Peabody, City of, Massachusetts
- 2767. Pembroke, Town of, Massachusetts
- 2768. Pepperell, Town of, Massachusetts
- 2769. Pittsfield, City of, Massachusetts
- 2770. Plymouth, County of, Massachusetts
- 2771. Plymouth, Town of, Massachusetts
- 2772. Quincy, City of, Massachusetts
- 2773. Randolph, Town of/ City of, Massachusetts
- 2774. Raynham, Town of, Massachusetts
- 2775. Reading, Town of, Massachusetts
- 2776. Rehoboth, Town of, Massachusetts
- 2777. Revere, City of, Massachusetts
- 2778. Rockland, Town of, Massachusetts
- 2779. Salem, City of, Massachusetts
- 2780. Sandwich, Town of, Massachusetts
- 2781. Saugus, Town of, Massachusetts
- 2782. Scituate, Town of, Massachusetts
- 2783. Seekonk, Town of, Massachusetts
- 2784. Sharon, Town of, Massachusetts
- 2785. Shrewsbury, Town of, Massachusetts
- 2786. Somerset, Town of, Massachusetts
- 2787. Somerville, City of, Massachusetts
- 2788. South Hadley, Town of, Massachusetts
- 2789. Southborough, Town of, Massachusetts
- 2790. Southbridge, Town of/ City of, Massachusetts
- 2791. Spencer, Town of, Massachusetts
- 2792. Springfield, City of, Massachusetts
- 2793. Stoneham, Town of, Massachusetts
- 2794. Stoughton, Town of, Massachusetts
- 2795. Sudbury, Town of, Massachusetts
- 2796. Swampscott, Town of, Massachusetts
- 2797. Swansea, Town of, Massachusetts
- 2798. Taunton, City of, Massachusetts
- 2799. Tewksbury, Town of, Massachusetts
- 2800. Tyngsborough, Town of, Massachusetts
- 2801. Uxbridge, Town of, Massachusetts
- 2802. Wakefield, Town of, Massachusetts
- 2803. Walpole, Town of, Massachusetts
- 2804. Waltham, City of, Massachusetts
- 2805. Wareham, Town of, Massachusetts
- 2806. Watertown, Town of/ City of, Massachusetts
- 2807. Wayland, Town of, Massachusetts
- 2808. Webster, Town of, Massachusetts
- 2809. Wellesley, Town of, Massachusetts
- 2810. West Springfield, Town of/ City of, Massachusetts
- 2811. Westborough, Town of, Massachusetts
- 2812. Westfield, City of, Massachusetts
- 2813. Westford, Town of, Massachusetts
- 2814. Weston, Town of, Massachusetts
- 2815. Westport, Town of, Massachusetts
- 2816. Westwood, Town of, Massachusetts
- 2817. Weymouth, Town of/ City of, Massachusetts
- 2818. Whitman, Town of, Massachusetts
- 2819. Wilbraham, Town of, Massachusetts
- 2820. Wilmington, Town of, Massachusetts
- 2821. Winchendon, Town of, Massachusetts
- 2822. Winchester, Town of, Massachusetts
- 2823. Winthrop, Town of/ City of, Massachusetts
- 2824. Woburn, City of, Massachusetts
- 2825. Worcester, City of, Massachusetts
- 2826. Wrentham, Town of, Massachusetts
- 2827. Yarmouth, Town of, Massachusetts

- 2828. Ada, Township of, Michigan
- 2829. Adrian, City of, Michigan
- 2830. Alcona, County of, Michigan
- 2831. Algoma, Township of, Michigan
- 2832. Allegan, County of, Michigan
- 2833. Allen Park, City of, Michigan
- 2834. Allendale, Charter Township of, Michigan
- 2835. Alpena, County of, Michigan
- 2836. Alpine, Township of, Michigan
- 2837. Ann Arbor, City of, Michigan
- 2838. Antrim, County of, Michigan
- 2839. Antwerp, Township of, Michigan
- 2840. Arenac, County of, Michigan
- 2841. Auburn Hills, City of, Michigan
- 2842. Bangor, Charter Township of, Michigan
- 2843. Barry, County of, Michigan
- 2844. Bath, Charter Township of, Michigan
- 2845. Battle Creek, City of, Michigan
- 2846. Bay City, City of, Michigan
- 2847. Bay, County of, Michigan
- 2848. Bedford, Township of, Michigan
- 2849. Benton, Charter Township of, Michigan
- 2850. Benzie, County of, Michigan
- 2851. Berkley, City of, Michigan
- 2852. Berrien, County of, Michigan
- 2853. Beverly Hills, Village of, Michigan
- 2854. Big Rapids, City of, Michigan
- 2855. Birmingham, City of, Michigan
- 2856. Blackman, Charter Township of, Michigan
- 2857. Bloomfield, Charter Township of, Michigan
- 2858. Branch, County of, Michigan
- 2859. Brandon, Charter Township of, Michigan
- 2860. Brighton, Township of, Michigan
- 2861. Brownstown, Charter Township of, Michigan
- 2862. Burton, City of, Michigan
- 2863. Byron, Township of, Michigan
- 2864. Cadillac, City of, Michigan
- 2865. Caledonia, Township of, Michigan
- 2866. Calhoun, County of, Michigan
- 2867. Cannon, Township of, Michigan
- 2868. Canton, Charter Township of, Michigan
- 2869. Cascade, Charter Township of, Michigan
- 2870. Cass, County of, Michigan
- 2871. Charlevoix, County of, Michigan
- 2872. Cheboygan, County of, Michigan
- 2873. Chesterfield, Township of, Michigan
- 2874. Chippewa, County of, Michigan
- 2875. Clare, County of, Michigan
- 2876. Clawson, City of, Michigan
- 2877. Clinton, Charter Township of, Michigan
- 2878. Clinton, County of, Michigan
- 2879. Coldwater, City of, Michigan
- 2880. Commerce, Charter Township of, Michigan
- 2881. Comstock, Charter Township of, Michigan
- 2882. Cooper, Charter Township of, Michigan
- 2883. Crawford, County of, Michigan
- 2884. Davison, Township of, Michigan
- 2885. Dearborn, City of, Michigan
- 2886. Dearborn Heights, City of, Michigan
- 2887. Delhi, Charter Township of, Michigan
- 2888. Delta, Charter Township of, Michigan
- 2889. Delta, County of, Michigan
- 2890. Detroit, City of, Michigan
- 2891. DeWitt, Charter Township of, Michigan
- 2892. Dickinson, County of, Michigan
- 2893. East Bay, Township of, Michigan
- 2894. East Grand Rapids, City of, Michigan
- 2895. East Lansing, City of, Michigan
- 2896. Eastpointe, City of, Michigan
- 2897. Eaton, County of, Michigan
- 2898. Egelston, Township of, Michigan
- 2899. Emmet, County of, Michigan
- 2900. Emmett, Charter Township of, Michigan

- 2901. Escanaba, City of, Michigan
- 2902. Farmington, City of, Michigan
- 2903. Farmington Hills, City of, Michigan
- 2904. Fenton, Charter Township of, Michigan
- 2905. Fenton, City of, Michigan
- 2906. Ferndale, City of, Michigan
- 2907. Flat Rock, City of, Michigan
- 2908. Flint, Charter Township of, Michigan
- 2909. Flint, City of, Michigan
- 2910. Flushing, Charter Township of, Michigan
- 2911. Fort Gratiot, Charter Township of, Michigan
- 2912. Fraser, City of, Michigan
- 2913. Frenchtown, Township of, Michigan
- 2914. Fruitport, Charter Township of, Michigan
- 2915. Gaines, Charter Township of, Michigan
- 2916. Garden City, City of, Michigan
- 2917. Garfield, Charter Township of, Michigan
- 2918. Genesee, Charter Township of, Michigan
- 2919. Genesee, County of, Michigan
- 2920. Genoa, Township of, Michigan
- 2921. Georgetown, Charter Township of, Michigan
- 2922. Gladwin, County of, Michigan
- 2923. Gogebic, County of, Michigan
- 2924. Grand Blanc, Charter Township of, Michigan
- 2925. Grand Haven, Charter Township of, Michigan
- 2926. Grand Haven, City of, Michigan
- 2927. Grand Rapids, Charter Township of, Michigan
- 2928. Grand Rapids, City of, Michigan
- 2929. Grand Traverse, County of, Michigan
- 2930. Grandville, City of, Michigan
- 2931. Gratiot, County of, Michigan
- 2932. Green Oak, Township of, Michigan
- 2933. Grosse Ile, Township of, Michigan
- 2934. Grosse Pointe Park, City of, Michigan
- 2935. Grosse Pointe Woods, City of, Michigan
- 2936. Hamburg, Township of, Michigan
- 2937. Hamtramck, City of, Michigan
- 2938. Harper Woods, City of, Michigan
- 2939. Harrison, Charter Township of, Michigan
- 2940. Hartland, Township of, Michigan
- 2941. Hazel Park, City of, Michigan
- 2942. Highland, Charter Township of, Michigan
- 2943. Highland Park, City of, Michigan
- 2944. Hillsdale, County of, Michigan
- 2945. Holland, Charter Township of, Michigan
- 2946. Holland, City of, Michigan
- 2947. Holly, Township of, Michigan
- 2948. Houghton, County of, Michigan
- 2949. Huron, Charter Township of, Michigan
- 2950. Huron, County of, Michigan
- 2951. Independence, Charter Township of, Michigan
- 2952. Ingham, County of, Michigan
- 2953. Inkster, City of, Michigan
- 2954. Ionia, City of, Michigan
- 2955. Ionia, County of, Michigan
- 2956. Iosco, County of, Michigan
- 2957. Iron, County of, Michigan
- 2958. Isabella, County of, Michigan
- 2959. Jackson, City of, Michigan
- 2960. Jackson, County of, Michigan
- 2961. Kalamazoo, Charter Township of, Michigan
- 2962. Kalamazoo, City of, Michigan
- 2963. Kalamazoo, County of, Michigan
- 2964. Kalkaska, County of, Michigan
- 2965. Kent, County of, Michigan
- 2966. Kentwood, City of, Michigan
- 2967. Lake, County of, Michigan
- 2968. Lansing, City of, Michigan
- 2969. Lapeer, County of, Michigan
- 2970. Leelanau, County of, Michigan
- 2971. Lenawee, County of, Michigan

- 2972. Lenox, Township of, Michigan
- 2973. Leoni, Township of, Michigan
- 2974. Lincoln, Charter Township of, Michigan
- 2975. Lincoln Park, City of, Michigan
- 2976. Livingston, County of, Michigan
- 2977. Livonia, City of, Michigan
- 2978. Lyon, Charter Township of, Michigan
- 2979. Mackinac, County of, Michigan
- 2980. Macomb, County of, Michigan
- 2981. Macomb, Township of, Michigan
- 2982. Madison Heights, City of, Michigan
- 2983. Manistee, County of, Michigan
- 2984. Marion, Township of, Michigan
- 2985. Marquette, City of, Michigan
- 2986. Marquette, County of, Michigan
- 2987. Mason, County of, Michigan
- 2988. Mecosta, County of, Michigan
- 2989. Melvindale, City of, Michigan
- 2990. Menominee, County of, Michigan
- 2991. Meridian, Charter Township of, Michigan
- 2992. Midland, City of, Michigan
- 2993. Midland, County of, Michigan
- 2994. Milford, Charter Township of, Michigan
- 2995. Missaukee, County of, Michigan
- 2996. Monitor, Charter Township of, Michigan
- 2997. Monroe, Charter Township of, Michigan
- 2998. Monroe, City of, Michigan
- 2999. Monroe, County of, Michigan
- 3000. Montcalm, County of, Michigan
- 3001. Mount Clemens, City of, Michigan
- 3002. Mount Morris, Township of, Michigan
- 3003. Mount Pleasant, City of, Michigan
- 3004. Mundy, Township of, Michigan
- 3005. Muskegon, Charter Township of, Michigan
- 3006. Muskegon, City of, Michigan
- 3007. Muskegon, County of, Michigan
- 3008. Muskegon Heights, City of, Michigan
- 3009. New Baltimore, City of, Michigan
- 3010. Newaygo, County of, Michigan
- 3011. Niles, City of, Michigan
- 3012. Niles, Township of, Michigan
- 3013. Northville, Township of, Michigan
- 3014. Norton Shores, City of, Michigan
- 3015. Novi, City of, Michigan
- 3016. Oak Park, City of, Michigan
- 3017. Oakland, Charter Township of, Michigan
- 3018. Oakland, County of, Michigan
- 3019. Oceana, County of, Michigan
- 3020. Oceola, Township of, Michigan
- 3021. Ogemaw, County of, Michigan
- 3022. Orion, Charter Township of, Michigan
- 3023. Osceola, County of, Michigan
- 3024. Oshtemo, Charter Township of, Michigan
- 3025. Otsego, County of, Michigan
- 3026. Ottawa, County of, Michigan
- 3027. Owosso, City of, Michigan
- 3028. Oxford, Charter Township of, Michigan
- 3029. Park, Township of, Michigan
- 3030. Pittsfield, Charter Township of, Michigan
- 3031. Plainfield, Charter Township of, Michigan
- 3032. Plymouth, Charter Township of, Michigan
- 3033. Pontiac, City of, Michigan
- 3034. Port Huron, Charter Township of, Michigan
- 3035. Port Huron, City of, Michigan
- 3036. Portage, City of, Michigan
- 3037. Presque Isle, County of, Michigan
- 3038. Redford, Charter Township of, Michigan
- 3039. Riverview, City of, Michigan
- 3040. Rochester, City of, Michigan
- 3041. Rochester Hills, City of, Michigan
- 3042. Romulus, City of, Michigan
- 3043. Roscommon, County of, Michigan
- 3044. Roseville, City of, Michigan
- 3045. Royal Oak, City of, Michigan



- 3046. Saginaw, Charter Township of, Michigan
- 3047. Saginaw, City of, Michigan
- 3048. Saginaw, County of, Michigan
- 3049. Sanilac, County of, Michigan
- 3050. Sault Ste. Marie, City of, Michigan
- 3051. Scio, Township of, Michigan
- 3052. Shelby, Charter Township of, Michigan
- 3053. Shiawassee, County of, Michigan
- 3054. South Lyon, City of, Michigan
- 3055. Southfield, City of, Michigan
- 3056. Southfield, Township of, Michigan
- 3057. Southgate, City of, Michigan
- 3058. Spring Lake, Township of, Michigan
- 3059. Springfield, Charter Township of, Michigan
- 3060. St. Clair, County of, Michigan
- 3061. St. Clair Shores, City of, Michigan
- 3062. St. Joseph, County of, Michigan
- 3063. Sterling Heights, City of, Michigan
- 3064. Sturgis, City of, Michigan
- 3065. Summit, Township of, Michigan
- 3066. Superior, Charter Township of, Michigan
- 3067. Taylor, City of, Michigan
- 3068. Texas, Charter Township of, Michigan
- 3069. Thomas, Township of, Michigan
- 3070. Traverse City, City of, Michigan
- 3071. Trenton, City of, Michigan
- 3072. Troy, City of, Michigan
- 3073. Tuscola, County of, Michigan
- 3074. Tyrone, Township of, Michigan
- 3075. Union, Charter Township of, Michigan
- 3076. Van Buren, Charter Township of, Michigan
- 3077. Van Buren, County of, Michigan
- 3078. Vienna, Charter Township of, Michigan
- 3079. Walker, City of, Michigan
- 3080. Warren, City of, Michigan
- 3081. Washington, Township of, Michigan
- 3082. Washtenaw, County of, Michigan
- 3083. Waterford, Charter Township of, Michigan
- 3084. Wayne, City of, Michigan
- 3085. Wayne, County of, Michigan
- 3086. West Bloomfield, Charter Township of, Michigan
- 3087. Westland, City of, Michigan
- 3088. Wexford, County of, Michigan
- 3089. White Lake, Charter Township of, Michigan
- 3090. Wixom, City of, Michigan
- 3091. Woodhaven, City of, Michigan
- 3092. Wyandotte, City of, Michigan
- 3093. Wyoming, City of, Michigan
- 3094. Ypsilanti, Charter Township of, Michigan
- 3095. Ypsilanti, City of, Michigan
- 3096. Zeeland, Charter Township of, Michigan
- 3097. Aitkin, County of, Minnesota
- 3098. Albert Lea, City of, Minnesota
- 3099. Alexandria, City of, Minnesota
- 3100. Andover, City of, Minnesota
- 3101. Anoka, City of, Minnesota
- 3102. Anoka, County of, Minnesota
- 3103. Apple Valley, City of, Minnesota
- 3104. Arden Hills, City of, Minnesota
- 3105. Austin, City of, Minnesota
- 3106. Becker, County of, Minnesota
- 3107. Beltrami, County of, Minnesota
- 3108. Bemidji, City of, Minnesota
- 3109. Benton, County of, Minnesota
- 3110. Big Lake, City of, Minnesota
- 3111. Blaine, City of, Minnesota
- 3112. Bloomington, City of, Minnesota
- 3113. Blue Earth, County of, Minnesota
- 3114. Brainerd, City of, Minnesota
- 3115. Brooklyn Center, City of, Minnesota
- 3116. Brooklyn Park, City of, Minnesota
- 3117. Brown, County of, Minnesota
- 3118. Buffalo, City of, Minnesota
- 3119. Burnsville, City of, Minnesota
- 3120. Carlton, County of, Minnesota
- 3121. Carver, County of, Minnesota
- 3122. Cass, County of, Minnesota
- 3123. Champlin, City of, Minnesota

- 3124. Chanhassen, City of, Minnesota
- 3125. Chaska, City of, Minnesota
- 3126. Chippewa, County of, Minnesota
- 3127. Chisago, County of, Minnesota
- 3128. Clay, County of, Minnesota
- 3129. Cloquet, City of, Minnesota
- 3130. Columbia Heights, City of, Minnesota
- 3131. Coon Rapids, City of, Minnesota
- 3132. Cottage Grove, City of, Minnesota
- 3133. Cottonwood, County of, Minnesota
- 3134. Crow Wing, County of, Minnesota
- 3135. Crystal, City of, Minnesota
- 3136. Dakota, County of, Minnesota
- 3137. Dodge, County of, Minnesota
- 3138. Douglas, County of, Minnesota
- 3139. Duluth, City of, Minnesota
- 3140. Eagan, City of, Minnesota
- 3141. East Bethel, City of, Minnesota
- 3142. Eden Prairie, City of, Minnesota
- 3143. Edina, City of, Minnesota
- 3144. Elk River, City of, Minnesota
- 3145. Fairmont, City of, Minnesota
- 3146. Faribault, City of, Minnesota
- 3147. Faribault, County of, Minnesota
- 3148. Farmington, City of, Minnesota
- 3149. Fergus Falls, City of, Minnesota
- 3150. Fillmore, County of, Minnesota
- 3151. Forest Lake, City of, Minnesota
- 3152. Freeborn, County of, Minnesota
- 3153. Fridley, City of, Minnesota
- 3154. Golden Valley, City of, Minnesota
- 3155. Goodhue, County of, Minnesota
- 3156. Grand Rapids, City of, Minnesota
- 3157. Ham Lake, City of, Minnesota
- 3158. Hastings, City of, Minnesota
- 3159. Hennepin, County of, Minnesota
- 3160. Hibbing, City of, Minnesota
- 3161. Hopkins, City of, Minnesota
- 3162. Houston, County of, Minnesota
- 3163. Hubbard, County of, Minnesota
- 3164. Hugo, City of, Minnesota
- 3165. Hutchinson, City of, Minnesota
- 3166. Inver Grove Heights, City of, Minnesota
- 3167. Isanti, County of, Minnesota
- 3168. Itasca, County of, Minnesota
- 3169. Kanabec, County of, Minnesota
- 3170. Kandiyohi, County of, Minnesota
- 3171. Koochiching, County of, Minnesota
- 3172. Lake, County of, Minnesota
- 3173. Lakeville, City of, Minnesota
- 3174. Le Sueur, County of, Minnesota
- 3175. Lino Lakes, City of, Minnesota
- 3176. Little Canada, City of, Minnesota
- 3177. Lyon, County of, Minnesota
- 3178. Mankato, City of, Minnesota
- 3179. Maple Grove, City of, Minnesota
- 3180. Maplewood, City of, Minnesota
- 3181. Marshall, City of, Minnesota
- 3182. Martin, County of, Minnesota
- 3183. McLeod, County of, Minnesota
- 3184. Meeker, County of, Minnesota
- 3185. Mendota Heights, City of, Minnesota
- 3186. Mille Lacs, County of, Minnesota
- 3187. Minneapolis, City of, Minnesota
- 3188. Minnetonka, City of, Minnesota
- 3189. Monticello, City of, Minnesota
- 3190. Moorhead, City of, Minnesota
- 3191. Morrison, County of, Minnesota
- 3192. Mounds View, City of, Minnesota
- 3193. Mower, County of, Minnesota
- 3194. New Brighton, City of, Minnesota
- 3195. New Hope, City of, Minnesota
- 3196. New Ulm, City of, Minnesota
- 3197. Nicollet, County of, Minnesota
- 3198. Nobles, County of, Minnesota
- 3199. North Branch, City of, Minnesota
- 3200. North Mankato, City of, Minnesota
- 3201. North St. Paul, City of, Minnesota
- 3202. Northfield, City of, Minnesota
- 3203. Oakdale, City of, Minnesota
- 3204. Olmsted, County of, Minnesota
- 3205. Otsego, City of, Minnesota
- 3206. Otter Tail, County of, Minnesota
- 3207. Owatonna, City of, Minnesota
- 3208. Pennington, County of, Minnesota
- 3209. Pine, County of, Minnesota
- 3210. Plymouth, City of, Minnesota
- 3211. Polk, County of, Minnesota
- 3212. Pope, County of, Minnesota
- 3213. Prior Lake, City of, Minnesota

- 3214. Ramsey, City of, Minnesota
- 3215. Ramsey, County of, Minnesota
- 3216. Red Wing, City of, Minnesota
- 3217. Redwood, County of, Minnesota
- 3218. Renville, County of, Minnesota
- 3219. Rice, County of, Minnesota
- 3220. Richfield, City of, Minnesota
- 3221. Robbinsdale, City of, Minnesota
- 3222. Rochester, City of, Minnesota
- 3223. Rogers, City of, Minnesota
- 3224. Roseau, County of, Minnesota
- 3225. Rosemount, City of, Minnesota
- 3226. Roseville, City of, Minnesota
- 3227. Sartell, City of, Minnesota
- 3228. Sauk Rapids, City of, Minnesota
- 3229. Savage, City of, Minnesota
- 3230. Scott, County of, Minnesota
- 3231. Shakopee, City of, Minnesota
- 3232. Sherburne, County of, Minnesota
- 3233. Shoreview, City of, Minnesota
- 3234. Sibley, County of, Minnesota
- 3235. South St. Paul, City of, Minnesota
- 3236. St. Cloud, City of, Minnesota
- 3237. St. Louis, County of, Minnesota
- 3238. St. Louis Park, City of, Minnesota
- 3239. St. Michael, City of, Minnesota
- 3240. St. Paul, City of, Minnesota
- 3241. St. Peter, City of, Minnesota
- 3242. Stearns, County of, Minnesota
- 3243. Steele, County of, Minnesota
- 3244. Stillwater, City of, Minnesota
- 3245. Todd, County of, Minnesota
- 3246. Vadnais Heights, City of, Minnesota
- 3247. Victoria, City of, Minnesota
- 3248. Wabasha, County of, Minnesota
- 3249. Waconia, City of, Minnesota
- 3250. Wadena, County of, Minnesota
- 3251. Waseca, County of, Minnesota
- 3252. Washington, County of, Minnesota
- 3253. Watonwan, County of, Minnesota
- 3254. West St. Paul, City of, Minnesota
- 3255. White Bear Lake, City of, Minnesota
- 3256. White Bear, Township of, Minnesota
- 3257. Willmar, City of, Minnesota
- 3258. Winona, City of, Minnesota
- 3259. Winona, County of, Minnesota
- 3260. Woodbury, City of, Minnesota
- 3261. Worthington, City of, Minnesota
- 3262. Wright, County of, Minnesota
- 3263. Adams, County of, Mississippi
- 3264. Alcorn, County of, Mississippi
- 3265. Amite, County of, Mississippi
- 3266. Attala, County of, Mississippi
- 3267. Bay St. Louis, City of, Mississippi
- 3268. Biloxi, City of, Mississippi
- 3269. Bolivar, County of, Mississippi
- 3270. Brandon, City of, Mississippi
- 3271. Brookhaven, City of, Mississippi
- 3272. Byram, City of, Mississippi
- 3273. Calhoun, County of, Mississippi
- 3274. Canton, City of, Mississippi
- 3275. Chickasaw, County of, Mississippi
- 3276. Clarke, County of, Mississippi
- 3277. Clarksdale, City of, Mississippi
- 3278. Clay, County of, Mississippi
- 3279. Cleveland, City of, Mississippi
- 3280. Clinton, City of, Mississippi
- 3281. Coahoma, County of, Mississippi
- 3282. Columbus, City of, Mississippi
- 3283. Copiah, County of, Mississippi
- 3284. Corinth, City of, Mississippi
- 3285. Covington, County of, Mississippi
- 3286. DeSoto, County of, Mississippi
- 3287. D'Iberville, City of, Mississippi
- 3288. Forrest, County of, Mississippi
- 3289. Gautier, City of, Mississippi
- 3290. George, County of, Mississippi
- 3291. Greene, County of, Mississippi
- 3292. Greenville, City of, Mississippi
- 3293. Greenwood, City of, Mississippi
- 3294. Grenada, City of, Mississippi
- 3295. Grenada, County of, Mississippi
- 3296. Gulfport, City of, Mississippi
- 3297. Hancock, County of, Mississippi
- 3298. Harrison, County of, Mississippi
- 3299. Hattiesburg, City of, Mississippi
- 3300. Hernando, City of, Mississippi
- 3301. Hinds, County of, Mississippi
- 3302. Holmes, County of, Mississippi
- 3303. Horn Lake, City of, Mississippi
- 3304. Itawamba, County of, Mississippi
- 3305. Jackson, City of, Mississippi

- 3306. Jackson, County of, Mississippi
- 3307. Jasper, County of, Mississippi
- 3308. Jefferson Davis, County of, Mississippi
- 3309. Jones, County of, Mississippi
- 3310. Lafayette, County of, Mississippi
- 3311. Lamar, County of, Mississippi
- 3312. Lauderdale, County of, Mississippi
- 3313. Laurel, City of, Mississippi
- 3314. Lawrence, County of, Mississippi
- 3315. Leake, County of, Mississippi
- 3316. Lee, County of, Mississippi
- 3317. Leflore, County of, Mississippi
- 3318. Lincoln, County of, Mississippi
- 3319. Long Beach, City of, Mississippi
- 3320. Lowndes, County of, Mississippi
- 3321. Madison, City of, Mississippi
- 3322. Madison, County of, Mississippi
- 3323. Marion, County of, Mississippi
- 3324. Marshall, County of, Mississippi
- 3325. McComb, City of, Mississippi
- 3326. Meridian, City of, Mississippi
- 3327. Monroe, County of, Mississippi
- 3328. Moss Point, City of, Mississippi
- 3329. Natchez, City of, Mississippi
- 3330. Neshoba, County of, Mississippi
- 3331. Newton, County of, Mississippi
- 3332. Noxubee, County of, Mississippi
- 3333. Ocean Springs, City of, Mississippi
- 3334. Oktibbeha, County of, Mississippi
- 3335. Olive Branch, City of, Mississippi
- 3336. Oxford, City of, Mississippi
- 3337. Panola, County of, Mississippi
- 3338. Pascagoula, City of, Mississippi
- 3339. Pearl, City of, Mississippi
- 3340. Pearl River, County of, Mississippi
- 3341. Perry, County of, Mississippi
- 3342. Petal, City of, Mississippi
- 3343. Picayune, City of, Mississippi
- 3344. Pike, County of, Mississippi
- 3345. Pontotoc, County of, Mississippi
- 3346. Prentiss, County of, Mississippi
- 3347. Rankin, County of, Mississippi
- 3348. Ridgeland, City of, Mississippi
- 3349. Scott, County of, Mississippi
- 3350. Simpson, County of, Mississippi
- 3351. Smith, County of, Mississippi
- 3352. Southaven, City of, Mississippi
- 3353. Starkville, City of, Mississippi
- 3354. Stone, County of, Mississippi
- 3355. Sunflower, County of, Mississippi
- 3356. Tallahatchie, County of, Mississippi
- 3357. Tate, County of, Mississippi
- 3358. Tippah, County of, Mississippi
- 3359. Tishomingo, County of, Mississippi
- 3360. Tupelo, City of, Mississippi
- 3361. Union, County of, Mississippi
- 3362. Vicksburg, City of, Mississippi
- 3363. Walthall, County of, Mississippi
- 3364. Warren, County of, Mississippi
- 3365. Washington, County of, Mississippi
- 3366. Wayne, County of, Mississippi
- 3367. West Point, City of, Mississippi
- 3368. Winston, County of, Mississippi
- 3369. Yalobusha, County of, Mississippi
- 3370. Yazoo City, City of, Mississippi
- 3371. Yazoo, County of, Mississippi
- 3372. Adair, County of, Missouri
- 3373. Andrew, County of, Missouri
- 3374. Arnold, City of, Missouri
- 3375. Audrain, County of, Missouri
- 3376. Ballwin, City of, Missouri
- 3377. Barry, County of, Missouri
- 3378. Barton, County of, Missouri
- 3379. Bates, County of, Missouri
- 3380. Bellefontaine Neighbors, City of, Missouri
- 3381. Belton, City of, Missouri
- 3382. Benton, County of, Missouri
- 3383. Blue Springs, City of, Missouri
- 3384. Bolivar, City of, Missouri
- 3385. Bollinger, County of, Missouri
- 3386. Boone, County of, Missouri
- 3387. Branson, City of, Missouri
- 3388. Bridgeton, City of, Missouri
- 3389. Buchanan, County of, Missouri
- 3390. Butler, County of, Missouri
- 3391. Callaway, County of, Missouri
- 3392. Camden, County of, Missouri
- 3393. Cape Girardeau, City of, Missouri
- 3394. Cape Girardeau, County of, Missouri
- 3395. Carthage, City of, Missouri

- 3396. Cass, County of, Missouri
- 3397. Cedar, County of, Missouri
- 3398. Chesterfield, City of, Missouri
- 3399. Christian, County of, Missouri
- 3400. Clay, County of, Missouri
- 3401. Clayton, City of, Missouri
- 3402. Clinton, County of, Missouri
- 3403. Cole, County of, Missouri
- 3404. Columbia, City of, Missouri
- 3405. Cooper, County of, Missouri
- 3406. Crawford, County of, Missouri
- 3407. Crestwood, City of, Missouri
- 3408. Creve Coeur, City of, Missouri
- 3409. Dallas, County of, Missouri
- 3410. Dardenne Prairie, City of, Missouri
- 3411. DeKalb, County of, Missouri
- 3412. Dent, County of, Missouri
- 3413. Douglas, County of, Missouri
- 3414. Dunklin, County of, Missouri
- 3415. Eureka, City of, Missouri
- 3416. Excelsior Springs, City of, Missouri
- 3417. Farmington, City of, Missouri
- 3418. Ferguson, City of, Missouri
- 3419. Festus, City of, Missouri
- 3420. Florissant, City of, Missouri
- 3421. Franklin, County of, Missouri
- 3422. Fulton, City of, Missouri
- 3423. Gasconade, County of, Missouri
- 3424. Gladstone, City of, Missouri
- 3425. Grain Valley, City of, Missouri
- 3426. Grandview, City of, Missouri
- 3427. Greene, County of, Missouri
- 3428. Hannibal, City of, Missouri
- 3429. Harrisonville, City of, Missouri
- 3430. Hazelwood, City of, Missouri
- 3431. Henry, County of, Missouri
- 3432. Howard, County of, Missouri
- 3433. Howell, County of, Missouri
- 3434. Independence, City of, Missouri
- 3435. Independence, Township of, Missouri
- 3436. Iron, County of, Missouri
- 3437. Jackson, City of, Missouri
- 3438. Jackson, County of, Missouri
- 3439. Jasper, County of, Missouri
- 3440. Jefferson City, City of, Missouri
- 3441. Jefferson, County of, Missouri
- 3442. Jennings, City of, Missouri
- 3443. Johnson, County of, Missouri
- 3444. Joplin, City of, Missouri
- 3445. Kansas City, City of, Missouri
- 3446. Kearney, City of, Missouri
- 3447. Kennett, City of, Missouri
- 3448. Kirksville, City of, Missouri
- 3449. Kirkwood, City of, Missouri
- 3450. Laclede, County of, Missouri
- 3451. Lafayette, County of, Missouri
- 3452. Lake St. Louis, City of, Missouri
- 3453. Lawrence, County of, Missouri
- 3454. Lebanon, City of, Missouri
- 3455. Lee's Summit, City of, Missouri
- 3456. Liberty, City of, Missouri
- 3457. Liberty, Township of, Missouri
- 3458. Lincoln, County of, Missouri
- 3459. Linn, County of, Missouri
- 3460. Livingston, County of, Missouri
- 3461. Macon, County of, Missouri
- 3462. Madison, County of, Missouri
- 3463. Manchester, City of, Missouri
- 3464. Marion, County of, Missouri
- 3465. Marshall, City of, Missouri
- 3466. Maryland Heights, City of, Missouri
- 3467. Maryville, City of, Missouri
- 3468. McDonald, County of, Missouri
- 3469. Mexico, City of, Missouri
- 3470. Miller, County of, Missouri
- 3471. Mississippi, County of, Missouri
- 3472. Moberly, City of, Missouri
- 3473. Moniteau, County of, Missouri
- 3474. Montgomery, County of, Missouri
- 3475. Morgan, County of, Missouri
- 3476. Neosho, City of, Missouri
- 3477. New Madrid, County of, Missouri
- 3478. Newton, County of, Missouri
- 3479. Nixa, City of, Missouri
- 3480. Nodaway, County of, Missouri
- 3481. O'Fallon, City of, Missouri
- 3482. Oregon, County of, Missouri
- 3483. Osage, County of, Missouri
- 3484. Overland, City of, Missouri
- 3485. Ozark, City of, Missouri
- 3486. Pemiscot, County of, Missouri

- 3487. Perry, County of, Missouri
- 3488. Pettis, County of, Missouri
- 3489. Phelps, County of, Missouri
- 3490. Pike, County of, Missouri
- 3491. Platte, County of, Missouri
- 3492. Polk, County of, Missouri
- 3493. Polk, Township of, Missouri
- 3494. Poplar Bluff, City of, Missouri
- 3495. Pulaski, County of, Missouri
- 3496. Ralls, County of, Missouri
- 3497. Randolph, County of, Missouri
- 3498. Ray, County of, Missouri
- 3499. Raymore, City of, Missouri
- 3500. Raytown, City of, Missouri
- 3501. Republic, City of, Missouri
- 3502. Ripley, County of, Missouri
- 3503. Rolla, City of, Missouri
- 3504. Saline, County of, Missouri
- 3505. Scott, County of, Missouri
- 3506. Sedalia, City of, Missouri
- 3507. Sikeston, City of, Missouri
- 3508. Smithville, City of, Missouri
- 3509. Springfield, City of, Missouri
- 3510. St. Ann, City of, Missouri
- 3511. St. Charles, City of, Missouri
- 3512. St. Charles, County of, Missouri
- 3513. St. Francois, County of, Missouri
- 3514. St. Joseph, City of, Missouri
- 3515. St. Louis, City of, Missouri
- 3516. St. Louis, County of, Missouri
- 3517. St. Peters, City of, Missouri
- 3518. Ste. Genevieve, County of, Missouri
- 3519. Stoddard, County of, Missouri
- 3520. Stone, County of, Missouri
- 3521. Taney, County of, Missouri
- 3522. Texas, County of, Missouri
- 3523. Town and Country, City of, Missouri
- 3524. Troy, City of, Missouri
- 3525. Union, City of, Missouri
- 3526. University City, City of, Missouri
- 3527. Vernon, County of, Missouri
- 3528. Warren, County of, Missouri
- 3529. Warrensburg, City of, Missouri
- 3530. Washington, City of, Missouri
- 3531. Washington, County of, Missouri
- 3532. Wayne, County of, Missouri
- 3533. Webb City, City of, Missouri
- 3534. Webster, County of, Missouri
- 3535. Webster Groves, City of, Missouri
- 3536. Wentzville, City of, Missouri
- 3537. West Plains, City of, Missouri
- 3538. Wildwood, City of, Missouri
- 3539. Wright, County of, Missouri
- 3540. Big Horn, County of, Montana
- 3541. Billings, City of, Montana
- 3542. Bozeman, City of, Montana
- 3543. Butte-Silver Bow, Montana
- 3544. Carbon, County of, Montana
- 3545. Cascade, County of, Montana
- 3546. Custer, County of, Montana
- 3547. Fergus, County of, Montana
- 3548. Flathead, County of, Montana
- 3549. Gallatin, County of, Montana
- 3550. Glacier, County of, Montana
- 3551. Great Falls, City of, Montana
- 3552. Helena, City of, Montana
- 3553. Hill, County of, Montana
- 3554. Jefferson, County of, Montana
- 3555. Kalispell, City of, Montana
- 3556. Lake, County of, Montana
- 3557. Lewis and Clark, County of, Montana
- 3558. Lincoln, County of, Montana
- 3559. Missoula, City of, Montana
- 3560. Missoula, County of, Montana
- 3561. Park, County of, Montana
- 3562. Ravalli, County of, Montana
- 3563. Richland, County of, Montana
- 3564. Roosevelt, County of, Montana
- 3565. Sanders, County of, Montana
- 3566. Yellowstone, County of, Montana
- 3567. Adams, County of, Nebraska
- 3568. Beatrice, City of, Nebraska
- 3569. Bellevue, City of, Nebraska
- 3570. Box Butte, County of, Nebraska
- 3571. Buffalo, County of, Nebraska
- 3572. Cass, County of, Nebraska
- 3573. Colfax, County of, Nebraska
- 3574. Columbus, City of, Nebraska
- 3575. Custer, County of, Nebraska
- 3576. Dakota, County of, Nebraska
- 3577. Dawson, County of, Nebraska

- 3578. Dodge, County of, Nebraska
- 3579. Douglas, County of, Nebraska
- 3580. Fremont, City of, Nebraska
- 3581. Gage, County of, Nebraska
- 3582. Grand Island, City of, Nebraska
- 3583. Hall, County of, Nebraska
- 3584. Hastings, City of, Nebraska
- 3585. Holt, County of, Nebraska
- 3586. Kearney, City of, Nebraska
- 3587. La Vista, City of, Nebraska
- 3588. Lancaster, County of, Nebraska
- 3589. Lexington, City of, Nebraska
- 3590. Lincoln, City of, Nebraska
- 3591. Lincoln, County of, Nebraska
- 3592. Madison, County of, Nebraska
- 3593. Norfolk, City of, Nebraska
- 3594. North Platte, City of, Nebraska
- 3595. Omaha, City of, Nebraska
- 3596. Otoe, County of, Nebraska
- 3597. Papillion, City of, Nebraska
- 3598. Platte, County of, Nebraska
- 3599. Red Willow, County of, Nebraska
- 3600. Saline, County of, Nebraska
- 3601. Sarpy, County of, Nebraska
- 3602. Saunders, County of, Nebraska
- 3603. Scotts Bluff, County of, Nebraska
- 3604. Scottsbluff, City of, Nebraska
- 3605. Seward, County of, Nebraska
- 3606. South Sioux City, City of, Nebraska
- 3607. Washington, County of, Nebraska
- 3608. York, County of, Nebraska
- 3609. Boulder City, City of, Nevada
- 3610. Carson, City of, Nevada
- 3611. Churchill, County of, Nevada
- 3612. Clark, County of, Nevada
- 3613. Douglas, County of, Nevada
- 3614. Elko, City of, Nevada
- 3615. Elko, County of, Nevada
- 3616. Fernley, City of, Nevada
- 3617. Henderson, City of, Nevada
- 3618. Humboldt, County of, Nevada
- 3619. Las Vegas, City of, Nevada
- 3620. Lyon, County of, Nevada
- 3621. Mesquite, City of, Nevada
- 3622. North Las Vegas, City of, Nevada
- 3623. Nye, County of, Nevada
- 3624. Reno, City of, Nevada
- 3625. Sparks, City of, Nevada
- 3626. Washoe, County of, Nevada
- 3627. Amherst, Town of, New Hampshire
- 3628. Bedford, Town of, New Hampshire
- 3629. Belknap, County of, New Hampshire
- 3630. Berlin, City of, New Hampshire
- 3631. Carroll, County of, New Hampshire
- 3632. Cheshire, County of, New Hampshire
- 3633. Claremont, City of, New Hampshire
- 3634. Concord, City of, New Hampshire
- 3635. Conway, Town of, New Hampshire
- 3636. Coos, County of, New Hampshire
- 3637. Derry, Town of, New Hampshire
- 3638. Dover, City of, New Hampshire
- 3639. Durham, Town of, New Hampshire
- 3640. Exeter, Town of, New Hampshire
- 3641. Goffstown, Town of, New Hampshire
- 3642. Grafton, County of, New Hampshire
- 3643. Hampton, Town of, New Hampshire
- 3644. Hanover, Town of, New Hampshire
- 3645. Hillsborough, County of, New Hampshire
- 3646. Hooksett, Town of, New Hampshire
- 3647. Hudson, Town of, New Hampshire
- 3648. Keene, City of, New Hampshire
- 3649. Laconia, City of, New Hampshire
- 3650. Lebanon, City of, New Hampshire
- 3651. Londonderry, Town of, New Hampshire
- 3652. Manchester, City of, New Hampshire
- 3653. Merrimack, County of, New Hampshire
- 3654. Merrimack, Town of, New Hampshire
- 3655. Milford, Town of, New Hampshire
- 3656. Nashua, City of, New Hampshire
- 3657. Pelham, Town of, New Hampshire
- 3658. Portsmouth, City of, New Hampshire
- 3659. Raymond, Town of, New Hampshire
- 3660. Rochester, City of, New Hampshire
- 3661. Rockingham, County of, New Hampshire
- 3662. Salem, Town of, New Hampshire

- 3663. Somersworth, City of, New Hampshire
- 3664. Strafford, County of, New Hampshire
- 3665. Sullivan, County of, New Hampshire
- 3666. Windham, Town of, New Hampshire
- 3667. Aberdeen, Township of, New Jersey
- 3668. Asbury Park, City of, New Jersey
- 3669. Atlantic City, City of, New Jersey
- 3670. Atlantic, County of, New Jersey
- 3671. Barnegat, Township of, New Jersey
- 3672. Bayonne, City of, New Jersey
- 3673. Beachwood, Borough of, New Jersey
- 3674. Belleville, Township of, New Jersey
- 3675. Bellmawr, Borough of, New Jersey
- 3676. Bergen, County of, New Jersey
- 3677. Bergenfield, Borough of, New Jersey
- 3678. Berkeley Heights, Township of, New Jersey
- 3679. Berkeley, Township of, New Jersey
- 3680. Bernards, Township of, New Jersey
- 3681. Bloomfield, Township of, New Jersey
- 3682. Bordentown, Township of, New Jersey
- 3683. Bound Brook, Borough of, New Jersey
- 3684. Branchburg, Township of, New Jersey
- 3685. Brick, Township of, New Jersey
- 3686. Bridgeton, City of, New Jersey
- 3687. Bridgewater, Township of, New Jersey
- 3688. Burlington, County of, New Jersey
- 3689. Burlington, Township of, New Jersey
- 3690. Camden, City of, New Jersey
- 3691. Camden, County of, New Jersey
- 3692. Cape May, County of, New Jersey
- 3693. Carteret, Borough of, New Jersey
- 3694. Cedar Grove, Township of, New Jersey
- 3695. Chatham, Township of, New Jersey
- 3696. Cherry Hill, Township of, New Jersey
- 3697. Cinnaminson, Township of, New Jersey
- 3698. City of Orange, Township of, New Jersey
- 3699. Clark, Township of, New Jersey
- 3700. Cliffside Park, Borough of, New Jersey
- 3701. Clifton, City of, New Jersey
- 3702. Clinton, Township of, New Jersey
- 3703. Collingswood, Borough of, New Jersey
- 3704. Cranford, Township of, New Jersey
- 3705. Cumberland, County of, New Jersey
- 3706. Delran, Township of, New Jersey
- 3707. Denville, Township of, New Jersey
- 3708. Deptford, Township of, New Jersey
- 3709. Dover, Town of, New Jersey
- 3710. Dumont, Borough of, New Jersey
- 3711. East Brunswick, Township of, New Jersey
- 3712. East Greenwich, Township of, New Jersey
- 3713. East Hanover, Township of, New Jersey
- 3714. East Orange, City of, New Jersey
- 3715. East Windsor, Township of, New Jersey
- 3716. Eatontown, Borough of, New Jersey
- 3717. Edgewater, Borough of, New Jersey
- 3718. Edison, Township of, New Jersey
- 3719. Egg Harbor, Township of, New Jersey
- 3720. Elizabeth, City of, New Jersey
- 3721. Elmwood Park, Borough of, New Jersey
- 3722. Englewood, City of, New Jersey
- 3723. Essex, County of, New Jersey
- 3724. Evesham, Township of, New Jersey
- 3725. Ewing, Township of, New Jersey
- 3726. Fair Lawn, Borough of, New Jersey
- 3727. Fairview, Borough of, New Jersey
- 3728. Florence, Township of, New Jersey
- 3729. Florham Park, Borough of, New Jersey
- 3730. Fort Lee, Borough of, New Jersey



- 3731. Franklin Lakes, Borough of, New Jersey
- 3732. Franklin, Township of, New Jersey
- 3733. Freehold, Borough of, New Jersey
- 3734. Freehold, Township of, New Jersey
- 3735. Galloway, Township of, New Jersey
- 3736. Garfield, City of, New Jersey
- 3737. Glassboro, Borough of, New Jersey
- 3738. Glen Rock, Borough of, New Jersey
- 3739. Gloucester City, City of, New Jersey
- 3740. Gloucester, County of, New Jersey
- 3741. Gloucester, Township of, New Jersey
- 3742. Guttenberg, Town of, New Jersey
- 3743. Hackensack, City of, New Jersey
- 3744. Haddon, Township of, New Jersey
- 3745. Haddonfield, Borough of, New Jersey
- 3746. Hamilton, Township of, New Jersey
- 3747. Hammonton, Town of, New Jersey
- 3748. Hanover, Township of, New Jersey
- 3749. Harrison, Town of, New Jersey
- 3750. Harrison, Township of, New Jersey
- 3751. Hasbrouck Heights, Borough of, New Jersey
- 3752. Hawthorne, Borough of, New Jersey
- 3753. Hazlet, Township of, New Jersey
- 3754. Highland Park, Borough of, New Jersey
- 3755. Hillsborough, Township of, New Jersey
- 3756. Hillsdale, Borough of, New Jersey
- 3757. Hillside, Township of, New Jersey
- 3758. Hoboken, City of, New Jersey
- 3759. Holmdel, Township of, New Jersey
- 3760. Hopatcong, Borough of, New Jersey
- 3761. Hopewell, Township of, New Jersey
- 3762. Howell, Township of, New Jersey
- 3763. Hudson, County of, New Jersey
- 3764. Hunterdon, County of, New Jersey
- 3765. Irvington, Township of, New Jersey
- 3766. Jackson, Township of, New Jersey
- 3767. Jefferson, Township of, New Jersey
- 3768. Jersey City, City of, New Jersey
- 3769. Kearny, Town of, New Jersey
- 3770. Lacey, Township of, New Jersey
- 3771. Lakewood, Township of, New Jersey
- 3772. Lawrence, Township of, New Jersey
- 3773. Lincoln Park, Borough of, New Jersey
- 3774. Linden, City of, New Jersey
- 3775. Lindenwold, Borough of, New Jersey
- 3776. Little Egg Harbor, Township of, New Jersey
- 3777. Little Falls, Township of, New Jersey
- 3778. Little Ferry, Borough of, New Jersey
- 3779. Livingston, Township of, New Jersey
- 3780. Lodi, Borough of, New Jersey
- 3781. Long Branch, City of, New Jersey
- 3782. Lower, Township of, New Jersey
- 3783. Lumberton, Township of, New Jersey
- 3784. Lyndhurst, Township of, New Jersey
- 3785. Madison, Borough of, New Jersey
- 3786. Mahwah, Township of, New Jersey
- 3787. Manalapan, Township of, New Jersey
- 3788. Manchester, Township of, New Jersey
- 3789. Mantua, Township of, New Jersey
- 3790. Manville, Borough of, New Jersey
- 3791. Maple Shade, Township of, New Jersey
- 3792. Maplewood, Township of, New Jersey
- 3793. Marlboro, Township of, New Jersey
- 3794. Medford, Township of, New Jersey
- 3795. Mercer, County of, New Jersey
- 3796. Metuchen, Borough of, New Jersey
- 3797. Middle, Township of, New Jersey
- 3798. Middlesex, Borough of, New Jersey
- 3799. Middlesex, County of, New Jersey
- 3800. Middletown, Township of, New Jersey
- 3801. Millburn, Township of, New Jersey
- 3802. Millstone, Township of, New Jersey
- 3803. Millville, City of, New Jersey
- 3804. Monmouth, County of, New Jersey
- 3805. Monroe, Township of, New Jersey

- 3806. Montclair, Township of, New Jersey
- 3807. Montgomery, Township of, New Jersey
- 3808. Montville, Township of, New Jersey
- 3809. Moorestown, Township of, New Jersey
- 3810. Morris, County of, New Jersey
- 3811. Morris, Township of, New Jersey
- 3812. Morristown, Town of, New Jersey
- 3813. Mount Laurel, Township of, New Jersey
- 3814. Mount Olive, Township of, New Jersey
- 3815. Neptune, Township of, New Jersey
- 3816. New Brunswick, City of, New Jersey
- 3817. New Milford, Borough of, New Jersey
- 3818. New Providence, Borough of, New Jersey
- 3819. Newark, City of, New Jersey
- 3820. North Arlington, Borough of, New Jersey
- 3821. North Bergen, Township of, New Jersey
- 3822. North Brunswick, Township of, New Jersey
- 3823. North Plainfield, Borough of, New Jersey
- 3824. Nutley, Township of, New Jersey
- 3825. Oakland, Borough of, New Jersey
- 3826. Ocean City, City of, New Jersey
- 3827. Ocean, County of, New Jersey
- 3828. Ocean, Township of, New Jersey
- 3829. Old Bridge, Township of, New Jersey
- 3830. Palisades Park, Borough of, New Jersey
- 3831. Paramus, Borough of, New Jersey
- 3832. Parsippany-Troy Hills, Township of, New Jersey
- 3833. Passaic, City of, New Jersey
- 3834. Passaic, County of, New Jersey
- 3835. Paterson, City of, New Jersey
- 3836. Pemberton, Township of, New Jersey
- 3837. Pennsauken, Township of, New Jersey
- 3838. Pennsville, Township of, New Jersey
- 3839. Pequannock, Township of, New Jersey
- 3840. Perth Amboy, City of, New Jersey
- 3841. Phillipsburg, Town of, New Jersey
- 3842. Pine Hill, Borough of, New Jersey
- 3843. Piscataway, Township of, New Jersey
- 3844. Plainfield, City of, New Jersey
- 3845. Plainsboro, Township of, New Jersey
- 3846. Pleasantville, City of, New Jersey
- 3847. Point Pleasant, Borough of, New Jersey
- 3848. Pompton Lakes, Borough of, New Jersey
- 3849. Princeton, New Jersey
- 3850. Rahway, City of, New Jersey
- 3851. Ramsey, Borough of, New Jersey
- 3852. Randolph, Township of, New Jersey
- 3853. Raritan, Township of, New Jersey
- 3854. Readington, Township of, New Jersey
- 3855. Red Bank, Borough of, New Jersey
- 3856. Ridgefield, Borough of, New Jersey
- 3857. Ridgefield Park, Village of, New Jersey
- 3858. Ridgewood, Village of, New Jersey
- 3859. Ringwood, Borough of, New Jersey
- 3860. River Edge, Borough of, New Jersey
- 3861. Robbinsville, Township of, New Jersey
- 3862. Rockaway, Township of, New Jersey
- 3863. Roselle, Borough of, New Jersey
- 3864. Roselle Park, Borough of, New Jersey
- 3865. Roxbury, Township of, New Jersey
- 3866. Rutherford, Borough of, New Jersey
- 3867. Saddle Brook, Township of, New Jersey
- 3868. Salem, County of, New Jersey
- 3869. Sayreville, Borough of, New Jersey
- 3870. Scotch Plains, Township of, New Jersey
- 3871. Secaucus, Town of, New Jersey

- 3872. Somers Point, City of, New Jersey
- 3873. Somerset, County of, New Jersey
- 3874. Somerville, Borough of, New Jersey
- 3875. South Brunswick, Township of, New Jersey
- 3876. South Orange Village, Township of, New Jersey
- 3877. South Plainfield, Borough of, New Jersey
- 3878. South River, Borough of, New Jersey
- 3879. Southampton, Township of, New Jersey
- 3880. Sparta, Township of, New Jersey
- 3881. Springfield, Township of, New Jersey
- 3882. Stafford, Township of, New Jersey
- 3883. Summit, City of, New Jersey
- 3884. Sussex, County of, New Jersey
- 3885. Teaneck, Township of, New Jersey
- 3886. Tenafly, Borough of, New Jersey
- 3887. Tinton Falls, Borough of, New Jersey
- 3888. Toms River, Township of, New Jersey
- 3889. Totowa, Borough of, New Jersey
- 3890. Trenton, City of, New Jersey
- 3891. Union City, City of, New Jersey
- 3892. Union, County of, New Jersey
- 3893. Union, Township of, New Jersey
- 3894. Upper, Township of, New Jersey
- 3895. Vernon, Township of, New Jersey
- 3896. Verona, Township of, New Jersey
- 3897. Vineland, City of, New Jersey
- 3898. Voorhees, Township of, New Jersey
- 3899. Waldwick, Borough of, New Jersey
- 3900. Wall, Township of, New Jersey
- 3901. Wallington, Borough of, New Jersey
- 3902. Wanaque, Borough of, New Jersey
- 3903. Wantage, Township of, New Jersey
- 3904. Warren, County of, New Jersey
- 3905. Warren, Township of, New Jersey
- 3906. Washington, Township of, New Jersey
- 3907. Waterford, Township of, New Jersey
- 3908. Wayne, Township of, New Jersey
- 3909. Weehawken, Township of, New Jersey
- 3910. West Caldwell, Township of, New Jersey
- 3911. West Deptford, Township of, New Jersey
- 3912. West Milford, Township of, New Jersey
- 3913. West New York, Town of, New Jersey
- 3914. West Orange, Township of, New Jersey
- 3915. West Windsor, Township of, New Jersey
- 3916. Westfield, Town of, New Jersey
- 3917. Westwood, Borough of, New Jersey
- 3918. Willingboro, Township of, New Jersey
- 3919. Winslow, Township of, New Jersey
- 3920. Woodbridge, Township of, New Jersey
- 3921. Woodland Park, Borough of, New Jersey
- 3922. Woolwich, Township of, New Jersey
- 3923. Wyckoff, Township of, New Jersey
- 3924. Albany, City of, New York
- 3925. Albany, County of, New York
- 3926. Allegany, County of, New York
- 3927. Amherst, Town of, New York
- 3928. Amsterdam, City of, New York
- 3929. Arcadia, Town of, New York
- 3930. Auburn, City of, New York
- 3931. Aurora, Town of, New York
- 3932. Babylon, Town of, New York
- 3933. Babylon, Village of, New York
- 3934. Ballston, Town of, New York
- 3935. Batavia, City of, New York
- 3936. Bath, Town of, New York
- 3937. Beacon, City of, New York
- 3938. Bedford, Town of, New York
- 3939. Beekman, Town of, New York
- 3940. Bethlehem, Town of, New York
- 3941. Binghamton, City of, New York
- 3942. Blooming Grove, Town of, New York
- 3943. Brighton, Town of, New York

- 3944. Bronx, County of, New York
- 3945. Brookhaven, Town of, New York
- 3946. Broome, County of, New York
- 3947. Brunswick, Town of, New York
- 3948. Buffalo, City of, New York
- 3949. Camillus, Town of, New York
- 3950. Canandaigua, City of, New York
- 3951. Canandaigua, Town of, New York
- 3952. Canton, Town of, New York
- 3953. Carmel, Town of, New York
- 3954. Catskill, Town of, New York
- 3955. Cattaraugus, County of, New York
- 3956. Cayuga, County of, New York
- 3957. Chautauqua, County of, New York
- 3958. Cheektowaga, Town of, New York
- 3959. Chemung, County of, New York
- 3960. Chenango, County of, New York
- 3961. Chenango, Town of, New York
- 3962. Chester, Town of, New York
- 3963. Chili, Town of, New York
- 3964. Cicero, Town of, New York
- 3965. Clarence, Town of, New York
- 3966. Clarkstown, Town of, New York
- 3967. Clay, Town of, New York
- 3968. Clifton Park, Town of, New York
- 3969. Clinton, County of, New York
- 3970. Cohoes, City of, New York
- 3971. Colonie, Town of, New York
- 3972. Columbia, County of, New York
- 3973. Corning, City of, New York
- 3974. Cornwall, Town of, New York
- 3975. Cortland, City of, New York
- 3976. Cortland, County of, New York
- 3977. Cortlandt, Town of, New York
- 3978. De Witt, Town of, New York
- 3979. Delaware, County of, New York
- 3980. Depew, Village of, New York
- 3981. Dobbs Ferry, Village of, New York
- 3982. Dryden, Town of, New York
- 3983. Dunkirk, City of, New York
- 3984. Dutchess, County of, New York
- 3985. East Fishkill, Town of, New York
- 3986. East Greenbush, Town of, New York
- 3987. East Hampton, Town of, New York
- 3988. Eastchester, Town of, New York
- 3989. Elma, Town of, New York
- 3990. Elmira, City of, New York
- 3991. Endicott, Village of, New York
- 3992. Erie, County of, New York
- 3993. Essex, County of, New York
- 3994. Evans, Town of, New York
- 3995. Fallsburg, Town of, New York
- 3996. Farmington, Town of, New York
- 3997. Fishkill, Town of, New York
- 3998. Floral Park, Village of, New York
- 3999. Franklin, County of, New York
- 4000. Fredonia, Village of, New York
- 4001. Freeport, Village of, New York
- 4002. Fulton, City of, New York
- 4003. Fulton, County of, New York
- 4004. Garden City, Village of, New York
- 4005. Gates, Town of, New York
- 4006. Geddes, Town of, New York
- 4007. Genesee, County of, New York
- 4008. Geneseo, Town of, New York
- 4009. Geneva, City of, New York
- 4010. German Flatts, Town of, New York
- 4011. Glen Cove, City of, New York
- 4012. Glens Falls, City of, New York
- 4013. Glenville, Town of, New York
- 4014. Gloversville, City of, New York
- 4015. Goshen, Town of, New York
- 4016. Grand Island, Town of, New York
- 4017. Great Neck, Village of, New York
- 4018. Greece, Town of, New York
- 4019. Greenburgh, Town of, New York
- 4020. Greene, County of, New York
- 4021. Guilderland, Town of, New York
- 4022. Halfmoon, Town of, New York
- 4023. Hamburg, Town of, New York
- 4024. Harrison, Town of, New York
- 4025. Harrison, Village of, New York
- 4026. Haverstraw, Town of, New York
- 4027. Haverstraw, Village of, New York
- 4028. Hempstead, Town of, New York
- 4029. Hempstead, Village of, New York
- 4030. Henrietta, Town of, New York
- 4031. Herkimer, County of, New York
- 4032. Highlands, Town of, New York
- 4033. Horseheads, Town of, New York
- 4034. Huntington, Town of, New York
- 4035. Hyde Park, Town of, New York

- 4036. Irondequoit, Town of, New York
- 4037. Islip, Town of, New York
- 4038. Ithaca, City of, New York
- 4039. Ithaca, Town of, New York
- 4040. Jamestown, City of, New York
- 4041. Jefferson, County of, New York
- 4042. Johnson City, Village of, New York
- 4043. Kenmore, Village of, New York
- 4044. Kent, Town of, New York
- 4045. Kings, County of, New York
- 4046. Kingsbury, Town of, New York
- 4047. Kingston, City of, New York
- 4048. Kirkland, Town of, New York
- 4049. Kiryas Joel, Village of, New York
- 4050. La Grange, Town of, New York
- 4051. Lackawanna, City of, New York
- 4052. Lake Grove, Village of, New York
- 4053. Lancaster, Town of, New York
- 4054. Lancaster, Village of, New York
- 4055. Lansing, Town of, New York
- 4056. Le Ray, Town of, New York
- 4057. Lewis, County of, New York
- 4058. Lewisboro, Town of, New York
- 4059. Lewiston, Town of, New York
- 4060. Lindenhurst, Village of, New York
- 4061. Livingston, County of, New York
- 4062. Lloyd, Town of, New York
- 4063. Lockport, City of, New York
- 4064. Lockport, Town of, New York
- 4065. Long Beach, City of, New York
- 4066. Lynbrook, Village of, New York
- 4067. Lysander, Town of, New York
- 4068. Madison, County of, New York
- 4069. Malone, Town of, New York
- 4070. Malta, Town of, New York
- 4071. Mamakating, Town of, New York
- 4072. Mamaroneck, Town of, New York
- 4073. Mamaroneck, Village of, New York
- 4074. Manlius, Town of, New York
- 4075. Massapequa Park, Village of, New York
- 4076. Massena, Town of, New York
- 4077. Massena, Village of, New York
- 4078. Middletown, City of, New York
- 4079. Milton, Town of, New York
- 4080. Mineola, Village of, New York
- 4081. Monroe, County of, New York
- 4082. Monroe, Town of, New York
- 4083. Montgomery, County of, New York
- 4084. Montgomery, Town of, New York
- 4085. Moreau, Town of, New York
- 4086. Mount Kisco, Village of/ Town of, New York
- 4087. Mount Pleasant, Town of, New York
- 4088. Mount Vernon, City of, New York
- 4089. Nassau, County of, New York
- 4090. New Castle, Town of, New York
- 4091. New Hartford, Town of, New York
- 4092. New Paltz, Town of, New York
- 4093. New Rochelle, City of, New York
- 4094. New Windsor, Town of, New York
- 4095. New York, City of, New York
- 4096. New York, County of, New York
- 4097. Newburgh, City of, New York
- 4098. Newburgh, Town of, New York
- 4099. Niagara, County of, New York
- 4100. Niagara Falls, City of, New York
- 4101. Niskayuna, Town of, New York
- 4102. North Castle, Town of, New York
- 4103. North Greenbush, Town of, New York
- 4104. North Hempstead, Town of, New York
- 4105. North Tonawanda, City of, New York
- 4106. Ogden, Town of, New York
- 4107. Ogdensburg, City of, New York
- 4108. Olean, City of, New York
- 4109. Oneida, City of, New York
- 4110. Oneida, County of, New York
- 4111. Oneonta, City of, New York
- 4112. Onondaga, County of, New York
- 4113. Onondaga, Town of, New York
- 4114. Ontario, County of, New York
- 4115. Ontario, Town of, New York
- 4116. Orange, County of, New York
- 4117. Orangetown, Town of, New York
- 4118. Orchard Park, Town of, New York
- 4119. Orleans, County of, New York
- 4120. Ossining, Town of, New York
- 4121. Ossining, Village of, New York
- 4122. Oswego, City of, New York

- 4123. Oswego, County of, New York
- 4124. Otsego, County of, New York
- 4125. Owego, Town of, New York
- 4126. Oyster Bay, Town of, New York
- 4127. Palm Tree, Town of, New York
- 4128. Parma, Town of, New York
- 4129. Patchogue, Village of, New York
- 4130. Patterson, Town of, New York
- 4131. Peekskill, City of, New York
- 4132. Pelham, Town of, New York
- 4133. Penfield, Town of, New York
- 4134. Perinton, Town of, New York
- 4135. Pittsford, Town of, New York
- 4136. Plattekill, Town of, New York
- 4137. Plattsburgh, City of, New York
- 4138. Plattsburgh, Town of, New York
- 4139. Pomfret, Town of, New York
- 4140. Port Chester, Village of, New York
- 4141. Potsdam, Town of, New York
- 4142. Poughkeepsie, City of, New York
- 4143. Poughkeepsie, Town of, New York
- 4144. Putnam, County of, New York
- 4145. Putnam Valley, Town of, New York
- 4146. Queens, County of, New York
- 4147. Queensbury, Town of, New York
- 4148. Ramapo, Town of, New York
- 4149. Red Hook, Town of, New York
- 4150. Rensselaer, County of, New York
- 4151. Richmond, County of, New York
- 4152. Riverhead, Town of, New York
- 4153. Rochester, City of, New York
- 4154. Rockland, County of, New York
- 4155. Rockville Centre, Village of, New York
- 4156. Rome, City of, New York
- 4157. Rotterdam, Town of, New York
- 4158. Rye, City of, New York
- 4159. Rye, Town of, New York
- 4160. Salina, Town of, New York
- 4161. Saratoga, County of, New York
- 4162. Saratoga Springs, City of, New York
- 4163. Saugerties, Town of, New York
- 4164. Scarsdale, Village of/ Scarsdale, Town of, New York
- 4165. Schenectady, City of, New York
- 4166. Schenectady, County of, New York
- 4167. Schodack, Town of, New York
- 4168. Schoharie, County of, New York
- 4169. Schuyler, County of, New York
- 4170. Seneca, County of, New York
- 4171. Shawangunk, Town of, New York
- 4172. Sleepy Hollow, Village of, New York
- 4173. Smithtown, Town of, New York
- 4174. Somers, Town of, New York
- 4175. Southampton, Town of, New York
- 4176. Southeast, Town of, New York
- 4177. Southold, Town of, New York
- 4178. Spring Valley, Village of, New York
- 4179. St. Lawrence, County of, New York
- 4180. Steuben, County of, New York
- 4181. Stony Point, Town of, New York
- 4182. Suffern, Village of, New York
- 4183. Suffolk, County of, New York
- 4184. Sullivan, County of, New York
- 4185. Sullivan, Town of, New York
- 4186. Sweden, Town of, New York
- 4187. Syracuse, City of, New York
- 4188. Tarrytown, Village of, New York
- 4189. Thompson, Town of, New York
- 4190. Tioga, County of, New York
- 4191. Tompkins, County of, New York
- 4192. Tonawanda, City of, New York
- 4193. Tonawanda, Town of, New York
- 4194. Troy, City of, New York
- 4195. Ulster, County of, New York
- 4196. Ulster, Town of, New York
- 4197. Union, Town of, New York
- 4198. Utica, City of, New York
- 4199. Valley Stream, Village of, New York
- 4200. Van Buren, Town of, New York
- 4201. Vestal, Town of, New York
- 4202. Victor, Town of, New York
- 4203. Wallkill, Town of, New York
- 4204. Wappinger, Town of, New York
- 4205. Warren, County of, New York
- 4206. Warwick, Town of, New York
- 4207. Washington, County of, New York
- 4208. Watertown, City of, New York
- 4209. Wawarsing, Town of, New York
- 4210. Wayne, County of, New York
- 4211. Webster, Town of, New York

- 4212. West Haverstraw, Village of, New York
- 4213. West Seneca, Town of, New York
- 4214. Westbury, Village of, New York
- 4215. Westchester, County of, New York
- 4216. Wheatfield, Town of, New York
- 4217. White Plains, City of, New York
- 4218. Whitestown, Town of, New York
- 4219. Wilton, Town of, New York
- 4220. Woodbury, Town of, New York
- 4221. Woodbury, Village of, New York
- 4222. Wyoming, County of, New York
- 4223. Yates, County of, New York
- 4224. Yonkers, City of, New York
- 4225. Yorktown, Town of, New York
- 4226. Alamance, County of, North Carolina
- 4227. Albemarle, City of, North Carolina
- 4228. Alexander, County of, North Carolina
- 4229. Alleghany, County of, North Carolina
- 4230. Anson, County of, North Carolina
- 4231. Apex, Town of, North Carolina
- 4232. Archdale, City of, North Carolina
- 4233. Ashe, County of, North Carolina
- 4234. Asheboro, City of, North Carolina
- 4235. Asheville, City of, North Carolina
- 4236. Avery, County of, North Carolina
- 4237. Beaufort, County of, North Carolina
- 4238. Belmont, City of, North Carolina
- 4239. Bertie, County of, North Carolina
- 4240. Bladen, County of, North Carolina
- 4241. Boone, Town of, North Carolina
- 4242. Brunswick, County of, North Carolina
- 4243. Buncombe, County of, North Carolina
- 4244. Burke, County of, North Carolina
- 4245. Burlington, City of, North Carolina
- 4246. Cabarrus, County of, North Carolina
- 4247. Caldwell, County of, North Carolina
- 4248. Camden, County of, North Carolina
- 4249. Carrboro, Town of, North Carolina
- 4250. Carteret, County of, North Carolina
- 4251. Cary, Town of, North Carolina
- 4252. Caswell, County of, North Carolina
- 4253. Catawba, County of, North Carolina
- 4254. Chapel Hill, Town of, North Carolina
- 4255. Charlotte, City of, North Carolina
- 4256. Chatham, County of, North Carolina
- 4257. Cherokee, County of, North Carolina
- 4258. Chowan, County of, North Carolina
- 4259. Clay, County of, North Carolina
- 4260. Clayton, Town of, North Carolina
- 4261. Clemmons, Village of, North Carolina
- 4262. Cleveland, County of, North Carolina
- 4263. Columbus, County of, North Carolina
- 4264. Concord, City of, North Carolina
- 4265. Cornelius, Town of, North Carolina
- 4266. Craven, County of, North Carolina
- 4267. Cumberland, County of, North Carolina
- 4268. Currituck, County of, North Carolina
- 4269. Dare, County of, North Carolina
- 4270. Davidson, County of, North Carolina
- 4271. Davidson, Town of, North Carolina
- 4272. Davie, County of, North Carolina
- 4273. Duplin, County of, North Carolina
- 4274. Durham, City of, North Carolina
- 4275. Durham, County of, North Carolina
- 4276. Eden, City of, North Carolina
- 4277. Edgecombe, County of, North Carolina
- 4278. Elizabeth City, City of, North Carolina
- 4279. Elon, Town of, North Carolina
- 4280. Fayetteville, City of, North Carolina
- 4281. Forsyth, County of, North Carolina
- 4282. Franklin, County of, North Carolina
- 4283. Fuquay-Varina, Town of, North Carolina
- 4284. Garner, Town of, North Carolina
- 4285. Gaston, County of, North Carolina
- 4286. Gastonia, City of, North Carolina
- 4287. Gates, County of, North Carolina
- 4288. Goldsboro, City of, North Carolina
- 4289. Graham, City of, North Carolina

- 4290. Granville, County of, North Carolina
- 4291. Greene, County of, North Carolina
- 4292. Greensboro, City of, North Carolina
- 4293. Greenville, City of, North Carolina
- 4294. Guilford, County of, North Carolina
- 4295. Halifax, County of, North Carolina
- 4296. Harnett, County of, North Carolina
- 4297. Harrisburg, Town of, North Carolina
- 4298. Havelock, City of, North Carolina
- 4299. Haywood, County of, North Carolina
- 4300. Henderson, City of, North Carolina
- 4301. Henderson, County of, North Carolina
- 4302. Hendersonville, City of, North Carolina
- 4303. Hertford, County of, North Carolina
- 4304. Hickory, City of, North Carolina
- 4305. High Point, City of, North Carolina
- 4306. Hoke, County of, North Carolina
- 4307. Holly Springs, Town of, North Carolina
- 4308. Hope Mills, Town of, North Carolina
- 4309. Huntersville, Town of, North Carolina
- 4310. Indian Trail, Town of, North Carolina
- 4311. Iredell, County of, North Carolina
- 4312. Jackson, County of, North Carolina
- 4313. Jacksonville, City of, North Carolina
- 4314. Johnston, County of, North Carolina
- 4315. Kannapolis, City of, North Carolina
- 4316. Kernersville, Town of, North Carolina
- 4317. Kings Mountain, City of, North Carolina
- 4318. Kinston, City of, North Carolina
- 4319. Knightdale, Town of, North Carolina
- 4320. Laurinburg, City of, North Carolina
- 4321. Lee, County of, North Carolina
- 4322. Leland, Town of, North Carolina
- 4323. Lenoir, City of, North Carolina
- 4324. Lenoir, County of, North Carolina
- 4325. Lewisville, Town of, North Carolina
- 4326. Lexington, City of, North Carolina
- 4327. Lincoln, County of, North Carolina
- 4328. Lincolnton, City of, North Carolina
- 4329. Lumberton, City of, North Carolina
- 4330. Macon, County of, North Carolina
- 4331. Madison, County of, North Carolina
- 4332. Martin, County of, North Carolina
- 4333. Matthews, Town of, North Carolina
- 4334. McDowell, County of, North Carolina
- 4335. Mebane, City of, North Carolina
- 4336. Mecklenburg, County of, North Carolina
- 4337. Mint Hill, Town of, North Carolina
- 4338. Mitchell, County of, North Carolina
- 4339. Monroe, City of, North Carolina
- 4340. Montgomery, County of, North Carolina
- 4341. Moore, County of, North Carolina
- 4342. Mooresville, Town of, North Carolina
- 4343. Morganton, City of, North Carolina
- 4344. Morrisville, Town of, North Carolina
- 4345. Mount Airy, City of, North Carolina
- 4346. Mount Holly, City of, North Carolina
- 4347. Nash, County of, North Carolina
- 4348. New Bern, City of, North Carolina
- 4349. New Hanover, County of, North Carolina
- 4350. Newton, City of, North Carolina
- 4351. Northampton, County of, North Carolina
- 4352. Onslow, County of, North Carolina
- 4353. Orange, County of, North Carolina
- 4354. Pamlico, County of, North Carolina
- 4355. Pasquotank, County of, North Carolina
- 4356. Pender, County of, North Carolina
- 4357. Perquimans, County of, North Carolina
- 4358. Person, County of, North Carolina
- 4359. Pinehurst, Village of, North Carolina
- 4360. Pitt, County of, North Carolina
- 4361. Polk, County of, North Carolina
- 4362. Raleigh, City of, North Carolina
- 4363. Randolph, County of, North Carolina
- 4364. Reidsville, City of, North Carolina



- 4365. Richmond, County of, North Carolina
- 4366. Roanoke Rapids, City of, North Carolina
- 4367. Robeson, County of, North Carolina
- 4368. Rockingham, County of, North Carolina
- 4369. Rocky Mount, City of, North Carolina
- 4370. Rowan, County of, North Carolina
- 4371. Rutherford, County of, North Carolina
- 4372. Salisbury, City of, North Carolina
- 4373. Sampson, County of, North Carolina
- 4374. Sanford, City of, North Carolina
- 4375. Scotland, County of, North Carolina
- 4376. Shelby, City of, North Carolina
- 4377. Smithfield, Town of, North Carolina
- 4378. Southern Pines, Town of, North Carolina
- 4379. Spring Lake, Town of, North Carolina
- 4380. Stallings, Town of, North Carolina
- 4381. Stanly, County of, North Carolina
- 4382. Statesville, City of, North Carolina
- 4383. Stokes, County of, North Carolina
- 4384. Summerfield, Town of, North Carolina
- 4385. Surry, County of, North Carolina
- 4386. Swain, County of, North Carolina
- 4387. Tarboro, Town of, North Carolina
- 4388. Thomasville, City of, North Carolina
- 4389. Transylvania, County of, North Carolina
- 4390. Union, County of, North Carolina
- 4391. Vance, County of, North Carolina
- 4392. Wake, County of, North Carolina
- 4393. Wake Forest, Town of, North Carolina
- 4394. Warren, County of, North Carolina
- 4395. Washington, County of, North Carolina
- 4396. Watauga, County of, North Carolina
- 4397. Waxhaw, Town of, North Carolina
- 4398. Wayne, County of, North Carolina
- 4399. Waynesville, Town of, North Carolina
- 4400. Weddington, Town of, North Carolina
- 4401. Wilkes, County of, North Carolina
- 4402. Wilmington, City of, North Carolina
- 4403. Wilson, City of, North Carolina
- 4404. Wilson, County of, North Carolina
- 4405. Winston-Salem, City of, North Carolina
- 4406. Yadkin, County of, North Carolina
- 4407. Yancey, County of, North Carolina
- 4408. Barnes, County of, North Dakota
- 4409. Bismarck, City of, North Dakota
- 4410. Burleigh, County of, North Dakota
- 4411. Cass, County of, North Dakota
- 4412. Dickinson, City of, North Dakota
- 4413. Fargo, City of, North Dakota
- 4414. Grand Forks, City of, North Dakota
- 4415. Grand Forks, County of, North Dakota
- 4416. Jamestown, City of, North Dakota
- 4417. Mandan, City of, North Dakota
- 4418. McKenzie, County of, North Dakota
- 4419. Minot, City of, North Dakota
- 4420. Morton, County of, North Dakota
- 4421. Mountrail, County of, North Dakota
- 4422. Ramsey, County of, North Dakota
- 4423. Richland, County of, North Dakota
- 4424. Rolette, County of, North Dakota
- 4425. Stark, County of, North Dakota
- 4426. Stutsman, County of, North Dakota
- 4427. Walsh, County of, North Dakota
- 4428. Ward, County of, North Dakota
- 4429. West Fargo, City of, North Dakota
- 4430. Williams, County of, North Dakota
- 4431. Williston, City of, North Dakota
- 4432. Adams, County of, Ohio
- 4433. Akron, City of, Ohio
- 4434. Allen, County of, Ohio
- 4435. Alliance, City of, Ohio
- 4436. American, Township of, Ohio
- 4437. Amherst, City of, Ohio
- 4438. Anderson, Township of, Ohio
- 4439. Ashland, City of, Ohio
- 4440. Ashland, County of, Ohio

- 4441. Ashtabula, City of, Ohio
- 4442. Ashtabula, County of, Ohio
- 4443. Ashtabula, Township of, Ohio
- 4444. Athens, City of, Ohio
- 4445. Athens, County of, Ohio
- 4446. Athens, Township of, Ohio
- 4447. Auglaize, County of, Ohio
- 4448. Aurora, City of, Ohio
- 4449. Austintown, Township of, Ohio
- 4450. Avon, City of, Ohio
- 4451. Avon Lake, City of, Ohio
- 4452. Bainbridge, Township of, Ohio
- 4453. Barberton, City of, Ohio
- 4454. Batavia, Township of, Ohio
- 4455. Bath, Township of, Ohio
- 4456. Bay, Village of, City of, Ohio
- 4457. Beachwood, City of, Ohio
- 4458. Beaver creek, City of, Ohio
- 4459. Beaver creek, Township of, Ohio
- 4460. Bedford, City of, Ohio
- 4461. Bedford Heights, City of, Ohio
- 4462. Bellefontaine, City of, Ohio
- 4463. Belmont, County of, Ohio
- 4464. Berea, City of, Ohio
- 4465. Bethel, Township of, Ohio
- 4466. Bexley, City of, Ohio
- 4467. Blue Ash, City of, Ohio
- 4468. Boardman, Township of, Ohio
- 4469. Bowling Green, City of, Ohio
- 4470. Brecksville, City of, Ohio
- 4471. Brimfield, Township of, Ohio
- 4472. Broadview Heights, City of, Ohio
- 4473. Brook Park, City of, Ohio
- 4474. Brooklyn, City of, Ohio
- 4475. Brown, County of, Ohio
- 4476. Brunswick, City of, Ohio
- 4477. Brunswick Hills, Township of, Ohio
- 4478. Bucyrus, City of, Ohio
- 4479. Butler, County of, Ohio
- 4480. Cambridge, City of, Ohio
- 4481. Cambridge, Township of, Ohio
- 4482. Canfield, Township of, Ohio
- 4483. Canton, City of, Ohio
- 4484. Canton, Township of, Ohio
- 4485. Carroll, County of, Ohio
- 4486. Celina, City of, Ohio
- 4487. Centerville, City of, Ohio
- 4488. Champaign, County of, Ohio
- 4489. Chester, Township of, Ohio
- 4490. Chillicothe, City of, Ohio
- 4491. Chippewa, Township of, Ohio
- 4492. Cincinnati, City of, Ohio
- 4493. Circleville, City of, Ohio
- 4494. Clark, County of, Ohio
- 4495. Clayton, City of, Ohio
- 4496. Clear Creek, Township of, Ohio
- 4497. Clermont, County of, Ohio
- 4498. Cleveland, City of, Ohio
- 4499. Cleveland Heights, City of, Ohio
- 4500. Clinton, County of, Ohio
- 4501. Clinton, Township of, Ohio
- 4502. Colerain, Township of, Ohio
- 4503. Columbiana, County of, Ohio
- 4504. Columbus, City of, Ohio
- 4505. Concord, Township of, Ohio
- 4506. Conneaut, City of, Ohio
- 4507. Copley, Township of, Ohio
- 4508. Coshocton, City of, Ohio
- 4509. Coshocton, County of, Ohio
- 4510. Coventry, Township of, Ohio
- 4511. Crawford, County of, Ohio
- 4512. Cuyahoga, County of, Ohio
- 4513. Cuyahoga Falls, City of, Ohio
- 4514. Darke, County of, Ohio
- 4515. Dayton, City of, Ohio
- 4516. Deerfield, Township of, Ohio
- 4517. Defiance, City of, Ohio
- 4518. Defiance, County of, Ohio
- 4519. Defiance, Township of, Ohio
- 4520. Delaware, City of, Ohio
- 4521. Delaware City, Township of, Ohio
- 4522. Delaware, County of, Ohio
- 4523. Delhi, Township of, Ohio
- 4524. Dover, City of, Ohio
- 4525. Dublin, City of, Ohio
- 4526. Duchouquet, Township of, Ohio
- 4527. East Cleveland, City of, Ohio
- 4528. East Liverpool, City of, Ohio
- 4529. Eastlake, City of, Ohio
- 4530. Elyria, City of, Ohio
- 4531. Englewood, City of, Ohio
- 4532. Erie, County of, Ohio

- 4533. Etna, Township of, Ohio
- 4534. Euclid, City of, Ohio
- 4535. Fairborn, City of, Ohio
- 4536. Fairfield, City of, Ohio
- 4537. Fairfield, County of, Ohio
- 4538. Fairfield, Township of, Ohio
- 4539. Fairview Park, City of, Ohio
- 4540. Falls, Township of, Ohio
- 4541. Fayette, County of, Ohio
- 4542. Findlay, City of, Ohio
- 4543. Forest Park, City of, Ohio
- 4544. Fostoria, City of, Ohio
- 4545. Franklin, City of, Ohio
- 4546. Franklin, County of, Ohio
- 4547. Franklin, Township of, Ohio
- 4548. Fremont, City of, Ohio
- 4549. Fulton, County of, Ohio
- 4550. Gahanna, City of, Ohio
- 4551. Gallia, County of, Ohio
- 4552. Garfield Heights, City of, Ohio
- 4553. Geauga, County of, Ohio
- 4554. Geneva, Township of, Ohio
- 4555. Genoa, Township of, Ohio
- 4556. Goshen, Township of, Ohio
- 4557. Granville, Township of, Ohio
- 4558. Green, City of, Ohio
- 4559. Green, Township of, Ohio
- 4560. Greene, County of, Ohio
- 4561. Greenville, City of, Ohio
- 4562. Greenville, Township of, Ohio
- 4563. Grove City, City of, Ohio
- 4564. Guernsey, County of, Ohio
- 4565. Hamilton, City of, Ohio
- 4566. Hamilton, County of, Ohio
- 4567. Hamilton, Township of, Ohio
- 4568. Hancock, County of, Ohio
- 4569. Hardin, County of, Ohio
- 4570. Harrison, City of, Ohio
- 4571. Harrison, County of, Ohio
- 4572. Harrison, Township of, Ohio
- 4573. Heath, City of, Ohio
- 4574. Henry, County of, Ohio
- 4575. Highland, County of, Ohio
- 4576. Hilliard, City of, Ohio
- 4577. Hocking, County of, Ohio
- 4578. Holmes, County of, Ohio
- 4579. Howland, Township of, Ohio
- 4580. Hubbard, Township of, Ohio
- 4581. Huber Heights, City of, Ohio
- 4582. Hudson, City of, Ohio
- 4583. Huron, County of, Ohio
- 4584. Huron, Township of, Ohio
- 4585. Ironton, City of, Ohio
- 4586. Jackson, County of, Ohio
- 4587. Jackson, Township of, Ohio
- 4588. Jefferson, County of, Ohio
- 4589. Jefferson, Township of, Ohio
- 4590. Kent, City of, Ohio
- 4591. Kettering, City of, Ohio
- 4592. Knox, County of, Ohio
- 4593. Lake, County of, Ohio
- 4594. Lake, Township of, Ohio
- 4595. Lakewood, City of, Ohio
- 4596. Lancaster, City of, Ohio
- 4597. Lancaster City, Township of, Ohio
- 4598. Lawrence, County of, Ohio
- 4599. Lawrence, Township of, Ohio
- 4600. Lebanon, City of, Ohio
- 4601. Lemon, Township of, Ohio
- 4602. Liberty, Township of, Ohio
- 4603. Licking, County of, Ohio
- 4604. Lima, City of, Ohio
- 4605. Logan, County of, Ohio
- 4606. London, City of, Ohio
- 4607. Lorain, City of, Ohio
- 4608. Lorain, County of, Ohio
- 4609. Loveland, City of, Ohio
- 4610. Lucas, County of, Ohio
- 4611. Lyndhurst, City of, Ohio
- 4612. Macedonia, City of, Ohio
- 4613. Mad River, Township of, Ohio
- 4614. Madison, County of, Ohio
- 4615. Madison, Township of, Ohio
- 4616. Mahoning, County of, Ohio
- 4617. Mansfield, City of, Ohio
- 4618. Maple Heights, City of, Ohio
- 4619. Marietta, City of, Ohio
- 4620. Marion, City of, Ohio
- 4621. Marion, County of, Ohio
- 4622. Marion, Township of, Ohio
- 4623. Marysville, City of, Ohio
- 4624. Mason, City of, Ohio

- 4625. Massillon, City of, Ohio
- 4626. Maumee, City of, Ohio
- 4627. Mayfield Heights, City of, Ohio
- 4628. Medina, City of, Ohio
- 4629. Medina City, Township of, Ohio
- 4630. Medina, County of, Ohio
- 4631. Meigs, County of, Ohio
- 4632. Mentor, City of, Ohio
- 4633. Mercer, County of, Ohio
- 4634. Miami, County of, Ohio
- 4635. Miami, Township of, Ohio
- 4636. Miamisburg, City of, Ohio
- 4637. Middleburg Heights, City of, Ohio
- 4638. Middletown, City of, Ohio
- 4639. Mifflin, Township of, Ohio
- 4640. Monclova, Township of, Ohio
- 4641. Monroe, City of, Ohio
- 4642. Monroe, County of, Ohio
- 4643. Monroe, Township of, Ohio
- 4644. Montgomery, City of, Ohio
- 4645. Montgomery, County of, Ohio
- 4646. Montville, Township of, Ohio
- 4647. Moorefield, Township of, Ohio
- 4648. Morgan, County of, Ohio
- 4649. Morrow, County of, Ohio
- 4650. Mount Vernon, City of, Ohio
- 4651. Muskingum, County of, Ohio
- 4652. New Albany, City of, Ohio
- 4653. New Franklin, City of, Ohio
- 4654. New Philadelphia, City of, Ohio
- 4655. Newark, City of, Ohio
- 4656. Niles, City of, Ohio
- 4657. Noble, County of, Ohio
- 4658. North Canton, City of, Ohio
- 4659. North Olmsted, City of, Ohio
- 4660. North Ridgeville, City of, Ohio
- 4661. North Royalton, City of, Ohio
- 4662. Norton, City of, Ohio
- 4663. Norwalk, City of, Ohio
- 4664. Norwich, Township of, Ohio
- 4665. Norwood, City of, Ohio
- 4666. Olmsted, Township of, Ohio
- 4667. Orange, Township of, Ohio
- 4668. Oregon, City of, Ohio
- 4669. Ottawa, County of, Ohio
- 4670. Oxford, City of, Ohio
- 4671. Oxford, Township of, Ohio
- 4672. Painesville, City of, Ohio
- 4673. Painesville, Township of, Ohio
- 4674. Paris, Township of, Ohio
- 4675. Parma, City of, Ohio
- 4676. Parma Heights, City of, Ohio
- 4677. Pataskala, City of, Ohio
- 4678. Paulding, County of, Ohio
- 4679. Pease, Township of, Ohio
- 4680. Perkins, Township of, Ohio
- 4681. Perry, County of, Ohio
- 4682. Perry, Township of, Ohio
- 4683. Perrysburg, City of, Ohio
- 4684. Perrysburg, Township of, Ohio
- 4685. Pickaway, County of, Ohio
- 4686. Pickerington, City of, Ohio
- 4687. Pierce, Township of, Ohio
- 4688. Pike, County of, Ohio
- 4689. Piqua, City of, Ohio
- 4690. Plain, Township of, Ohio
- 4691. Pleasant, Township of, Ohio
- 4692. Poland, Township of, Ohio
- 4693. Portage, County of, Ohio
- 4694. Portsmouth, City of, Ohio
- 4695. Powell, City of, Ohio
- 4696. Prairie, Township of, Ohio
- 4697. Preble, County of, Ohio
- 4698. Putnam, County of, Ohio
- 4699. Ravenna, City of, Ohio
- 4700. Reading, City of, Ohio
- 4701. Reynoldsburg, City of, Ohio
- 4702. Richland, County of, Ohio
- 4703. Richland, Township of, Ohio
- 4704. Richmond Heights, City of, Ohio
- 4705. Riverside, City of, Ohio
- 4706. Rocky River, City of, Ohio
- 4707. Ross, County of, Ohio
- 4708. Sagamore Hills, Township of, Ohio
- 4709. Salem, City of, Ohio
- 4710. Sandusky, City of, Ohio
- 4711. Sandusky, County of, Ohio
- 4712. Scioto, County of, Ohio
- 4713. Scioto, Township of, Ohio
- 4714. Seneca, County of, Ohio
- 4715. Seven Hills, City of, Ohio
- 4716. Shaker Heights, City of, Ohio

- 4717. Sharon, Township of, Ohio
- 4718. Sharonville, City of, Ohio
- 4719. Shawnee, Township of, Ohio
- 4720. Shelby, County of, Ohio
- 4721. Sidney, City of, Ohio
- 4722. Solon, City of, Ohio
- 4723. South Euclid, City of, Ohio
- 4724. Springboro, City of, Ohio
- 4725. Springdale, City of, Ohio
- 4726. Springfield, City of, Ohio
- 4727. Springfield, Township of, Ohio
- 4728. St. Marys, Township of, Ohio
- 4729. Stark, County of, Ohio
- 4730. Steubenville, City of, Ohio
- 4731. Stow, City of, Ohio
- 4732. Streetsboro, City of, Ohio
- 4733. Strongsville, City of, Ohio
- 4734. Struthers, City of, Ohio
- 4735. Summit, County of, Ohio
- 4736. Sycamore, Township of, Ohio
- 4737. Sylvania, City of, Ohio
- 4738. Sylvania, Township of, Ohio
- 4739. Symmes, Township of, Ohio
- 4740. Tallmadge, City of, Ohio
- 4741. Tiffin, City of, Ohio
- 4742. Tipp City, City of, Ohio
- 4743. Toledo, City of, Ohio
- 4744. Trenton, City of, Ohio
- 4745. Trotwood, City of, Ohio
- 4746. Troy, City of, Ohio
- 4747. Trumbull, County of, Ohio
- 4748. Truro, Township of, Ohio
- 4749. Turtlecreek, Township of, Ohio
- 4750. Tuscarawas, County of, Ohio
- 4751. Twinsburg, City of, Ohio
- 4752. Union, County of, Ohio
- 4753. Union, Township of, Ohio
- 4754. University Heights, City of, Ohio
- 4755. Upper Arlington, City of, Ohio
- 4756. Upper, Township of, Ohio
- 4757. Urbana, City of, Ohio
- 4758. Urbana, Township of, Ohio
- 4759. Van Wert, City of, Ohio
- 4760. Van Wert, County of, Ohio
- 4761. Vandalia, City of, Ohio
- 4762. Vermilion, City of, Ohio
- 4763. Vinton, County of, Ohio
- 4764. Violet, Township of, Ohio
- 4765. Wadsworth, City of, Ohio
- 4766. Warren, City of, Ohio
- 4767. Warren, County of, Ohio
- 4768. Warrensville Heights, City of, Ohio
- 4769. Washington, County of, Ohio
- 4770. Washington Court House, City of, Ohio
- 4771. Washington, Township of, Ohio
- 4772. Wayne, County of, Ohio
- 4773. Weathersfield, Township of, Ohio
- 4774. West Carrollton, City of, Ohio
- 4775. West Chester, Township of, Ohio
- 4776. Westerville, City of, Ohio
- 4777. Westlake, City of, Ohio
- 4778. Whitehall, City of, Ohio
- 4779. Wickliffe, City of, Ohio
- 4780. Williams, County of, Ohio
- 4781. Willoughby, City of, Ohio
- 4782. Willowick, City of, Ohio
- 4783. Wilmington, City of, Ohio
- 4784. Wood, County of, Ohio
- 4785. Wooster, City of, Ohio
- 4786. Worthington, City of, Ohio
- 4787. Wyandot, County of, Ohio
- 4788. Xenia, City of, Ohio
- 4789. Youngstown, City of, Ohio
- 4790. Zanesville, City of, Ohio
- 4791. Ada, City of, Oklahoma
- 4792. Adair, County of, Oklahoma
- 4793. Altus, City of, Oklahoma
- 4794. Ardmore, City of, Oklahoma
- 4795. Atoka, County of, Oklahoma
- 4796. Bartlesville, City of, Oklahoma
- 4797. Beckham, County of, Oklahoma
- 4798. Bethany, City of, Oklahoma
- 4799. Bixby, City of, Oklahoma
- 4800. Broken Arrow, City of, Oklahoma
- 4801. Bryan, County of, Oklahoma
- 4802. Caddo, County of, Oklahoma
- 4803. Canadian, County of, Oklahoma
- 4804. Carter, County of, Oklahoma
- 4805. Cherokee, County of, Oklahoma
- 4806. Chickasha, City of, Oklahoma
- 4807. Choctaw, City of, Oklahoma

- 4808. Choctaw, County of, Oklahoma
- 4809. Claremore, City of, Oklahoma
- 4810. Cleveland, County of, Oklahoma
- 4811. Comanche, County of, Oklahoma
- 4812. Coweta, City of, Oklahoma
- 4813. Craig, County of, Oklahoma
- 4814. Creek, County of, Oklahoma
- 4815. Custer, County of, Oklahoma
- 4816. Del City, City of, Oklahoma
- 4817. Delaware, County of, Oklahoma
- 4818. Duncan, City of, Oklahoma
- 4819. Durant, City of, Oklahoma
- 4820. Edmond, City of, Oklahoma
- 4821. El Reno, City of, Oklahoma
- 4822. Elk City, City of, Oklahoma
- 4823. Enid, City of, Oklahoma
- 4824. Garfield, County of, Oklahoma
- 4825. Garvin, County of, Oklahoma
- 4826. Glenpool, City of, Oklahoma
- 4827. Grady, County of, Oklahoma
- 4828. Guthrie, City of, Oklahoma
- 4829. Guymon, City of, Oklahoma
- 4830. Haskell, County of, Oklahoma
- 4831. Hughes, County of, Oklahoma
- 4832. Jackson, County of, Oklahoma
- 4833. Jenks, City of, Oklahoma
- 4834. Johnston, County of, Oklahoma
- 4835. Kay, County of, Oklahoma
- 4836. Kingfisher, County of, Oklahoma
- 4837. Latimer, County of, Oklahoma
- 4838. Lawton, City of, Oklahoma
- 4839. Le Flore, County of, Oklahoma
- 4840. Lincoln, County of, Oklahoma
- 4841. Logan, County of, Oklahoma
- 4842. Love, County of, Oklahoma
- 4843. Marshall, County of, Oklahoma
- 4844. Mayes, County of, Oklahoma
- 4845. McAlester, City of, Oklahoma
- 4846. McClain, County of, Oklahoma
- 4847. McCurtain, County of, Oklahoma
- 4848. McIntosh, County of, Oklahoma
- 4849. Miami, City of, Oklahoma
- 4850. Midwest City, City of, Oklahoma
- 4851. Moore, City of, Oklahoma
- 4852. Murray, County of, Oklahoma
- 4853. Muskogee, City of, Oklahoma
- 4854. Muskogee, County of, Oklahoma
- 4855. Mustang, City of, Oklahoma
- 4856. Newcastle, City of, Oklahoma
- 4857. Noble, County of, Oklahoma
- 4858. Norman, City of, Oklahoma
- 4859. Nowata, County of, Oklahoma
- 4860. Okfuskee, County of, Oklahoma
- 4861. Oklahoma City, City of, Oklahoma
- 4862. Oklahoma, County of, Oklahoma
- 4863. Okmulgee, City of, Oklahoma
- 4864. Okmulgee, County of, Oklahoma
- 4865. Osage, County of, Oklahoma
- 4866. Ottawa, County of, Oklahoma
- 4867. Owasso, City of, Oklahoma
- 4868. Pawnee, County of, Oklahoma
- 4869. Payne, County of, Oklahoma
- 4870. Pittsburg, County of, Oklahoma
- 4871. Ponca City, City of, Oklahoma
- 4872. Pontotoc, County of, Oklahoma
- 4873. Pottawatomie, County of, Oklahoma
- 4874. Pushmataha, County of, Oklahoma
- 4875. Rogers, County of, Oklahoma
- 4876. Sand Springs, City of, Oklahoma
- 4877. Sapulpa, City of, Oklahoma
- 4878. Seminole, County of, Oklahoma
- 4879. Sequoyah, County of, Oklahoma
- 4880. Shawnee, City of, Oklahoma
- 4881. Stephens, County of, Oklahoma
- 4882. Stillwater, City of, Oklahoma
- 4883. Tahlequah, City of, Oklahoma
- 4884. Texas, County of, Oklahoma
- 4885. Tulsa, City of, Oklahoma
- 4886. Tulsa, County of, Oklahoma
- 4887. Wagoner, County of, Oklahoma
- 4888. Warr Acres, City of, Oklahoma
- 4889. Washington, County of, Oklahoma
- 4890. Washita, County of, Oklahoma
- 4891. Weatherford, City of, Oklahoma
- 4892. Woodward, City of, Oklahoma
- 4893. Woodward, County of, Oklahoma
- 4894. Yukon, City of, Oklahoma
- 4895. Albany, City of, Oregon
- 4896. Ashland, City of, Oregon
- 4897. Astoria, City of, Oregon
- 4898. Baker, County of, Oregon
- 4899. Beaverton, City of, Oregon

- 4900. Bend, City of, Oregon
- 4901. Benton, County of, Oregon
- 4902. Canby, City of, Oregon
- 4903. Central Point, City of, Oregon
- 4904. Clackamas, County of, Oregon
- 4905. Clatsop, County of, Oregon
- 4906. Columbia, County of, Oregon
- 4907. Coos Bay, City of, Oregon
- 4908. Coos, County of, Oregon
- 4909. Cornelius, City of, Oregon
- 4910. Corvallis, City of, Oregon
- 4911. Cottage Grove, City of, Oregon
- 4912. Crook, County of, Oregon
- 4913. Curry, County of, Oregon
- 4914. Dallas, City of, Oregon
- 4915. Deschutes, County of, Oregon
- 4916. Douglas, County of, Oregon
- 4917. Eugene, City of, Oregon
- 4918. Forest Grove, City of, Oregon
- 4919. Gladstone, City of, Oregon
- 4920. Grants Pass, City of, Oregon
- 4921. Gresham, City of, Oregon
- 4922. Happy Valley, City of, Oregon
- 4923. Hermiston, City of, Oregon
- 4924. Hillsboro, City of, Oregon
- 4925. Hood River, County of, Oregon
- 4926. Independence, City of, Oregon
- 4927. Jackson, County of, Oregon
- 4928. Jefferson, County of, Oregon
- 4929. Josephine, County of, Oregon
- 4930. Keizer, City of, Oregon
- 4931. Klamath, County of, Oregon
- 4932. Klamath Falls, City of, Oregon
- 4933. La Grande, City of, Oregon
- 4934. Lake Oswego, City of, Oregon
- 4935. Lane, County of, Oregon
- 4936. Lebanon, City of, Oregon
- 4937. Lincoln, County of, Oregon
- 4938. Linn, County of, Oregon
- 4939. Malheur, County of, Oregon
- 4940. Marion, County of, Oregon
- 4941. McMinnville, City of, Oregon
- 4942. Medford, City of, Oregon
- 4943. Milwaukie, City of, Oregon
- 4944. Monmouth, City of, Oregon
- 4945. Morrow, County of, Oregon
- 4946. Multnomah, County of, Oregon
- 4947. Newberg, City of, Oregon
- 4948. Newport, City of, Oregon
- 4949. Ontario, City of, Oregon
- 4950. Oregon City, City of, Oregon
- 4951. Pendleton, City of, Oregon
- 4952. Polk, County of, Oregon
- 4953. Portland, City of, Oregon
- 4954. Prineville, City of, Oregon
- 4955. Redmond, City of, Oregon
- 4956. Roseburg, City of, Oregon
- 4957. Salem, City of, Oregon
- 4958. Sandy, City of, Oregon
- 4959. Sherwood, City of, Oregon
- 4960. Silverton, City of, Oregon
- 4961. Springfield, City of, Oregon
- 4962. St. Helens, City of, Oregon
- 4963. The Dalles, City of, Oregon
- 4964. Tigard, City of, Oregon
- 4965. Tillamook, County of, Oregon
- 4966. Troutdale, City of, Oregon
- 4967. Tualatin, City of, Oregon
- 4968. Umatilla, County of, Oregon
- 4969. Union, County of, Oregon
- 4970. Wasco, County of, Oregon
- 4971. Washington, County of, Oregon
- 4972. West Linn, City of, Oregon
- 4973. Wilsonville, City of, Oregon
- 4974. Woodburn, City of, Oregon
- 4975. Yamhill, County of, Oregon
- 4976. Abington, Township of,  
Pennsylvania
- 4977. Adams, County of, Pennsylvania
- 4978. Adams, Township of, Pennsylvania
- 4979. Allegheny, County of, Pennsylvania
- 4980. Allentown, City of, Pennsylvania
- 4981. Altoona, City of, Pennsylvania
- 4982. Amity, Township of, Pennsylvania
- 4983. Antrim, Township of, Pennsylvania
- 4984. Armstrong, County of, Pennsylvania
- 4985. Aston, Township of, Pennsylvania
- 4986. Baldwin, Borough of, Pennsylvania
- 4987. Beaver, County of, Pennsylvania
- 4988. Bedford, County of, Pennsylvania
- 4989. Bensalem, Township of,  
Pennsylvania

- 4990. Berks, County of, Pennsylvania
- 4991. Bethel Park, Municipality of, Pennsylvania
- 4992. Bethlehem, City of, Pennsylvania
- 4993. Bethlehem, Township of, Pennsylvania
- 4994. Blair, County of, Pennsylvania
- 4995. Bloomsburg, Town of, Pennsylvania
- 4996. Bradford, County of, Pennsylvania
- 4997. Bristol, Township of, Pennsylvania
- 4998. Buckingham, Township of, Pennsylvania
- 4999. Bucks, County of, Pennsylvania
- 5000. Butler, City of, Pennsylvania
- 5001. Butler, County of, Pennsylvania
- 5002. Butler, Township of, Pennsylvania
- 5003. Caln, Township of, Pennsylvania
- 5004. Cambria, County of, Pennsylvania
- 5005. Carbon, County of, Pennsylvania
- 5006. Carlisle, Borough of, Pennsylvania
- 5007. Cecil, Township of, Pennsylvania
- 5008. Center, Township of, Pennsylvania
- 5009. Centre, County of, Pennsylvania
- 5010. Chambersburg, Borough of, Pennsylvania
- 5011. Cheltenham, Township of, Pennsylvania
- 5012. Chester, City of, Pennsylvania
- 5013. Chester, County of, Pennsylvania
- 5014. Chestnuthill, Township of, Pennsylvania
- 5015. Clarion, County of, Pennsylvania
- 5016. Clearfield, County of, Pennsylvania
- 5017. Clinton, County of, Pennsylvania
- 5018. Coal, Township of, Pennsylvania
- 5019. Coatesville, City of, Pennsylvania
- 5020. College, Township of, Pennsylvania
- 5021. Columbia, Borough of, Pennsylvania
- 5022. Columbia, County of, Pennsylvania
- 5023. Concord, Township of, Pennsylvania
- 5024. Coolbaugh, Township of, Pennsylvania
- 5025. Cranberry, Township of, Pennsylvania
- 5026. Crawford, County of, Pennsylvania
- 5027. Cumberland, County of, Pennsylvania
- 5028. Cumru, Township of, Pennsylvania
- 5029. Darby, Borough of, Pennsylvania
- 5030. Dauphin, County of, Pennsylvania
- 5031. Delaware, County of, Pennsylvania
- 5032. Derry, Township of, Pennsylvania
- 5033. Dingman, Township of, Pennsylvania
- 5034. Douglass, Township of, Pennsylvania
- 5035. Dover, Township of, Pennsylvania
- 5036. Doylestown, Township of, Pennsylvania
- 5037. Dunmore, Borough of, Pennsylvania
- 5038. East Cocalico, Township of, Pennsylvania
- 5039. East Goshen, Township of, Pennsylvania
- 5040. East Hempfield, Township of, Pennsylvania
- 5041. East Lampeter, Township of, Pennsylvania
- 5042. East Norriton, Township of, Pennsylvania
- 5043. East Pennsboro, Township of, Pennsylvania
- 5044. East Stroudsburg, Borough of, Pennsylvania
- 5045. East Whiteland, Township of, Pennsylvania
- 5046. Easton, City of, Pennsylvania
- 5047. Easttown, Township of, Pennsylvania
- 5048. Elizabeth, Township of, Pennsylvania
- 5049. Elizabethtown, Borough of, Pennsylvania
- 5050. Elk, County of, Pennsylvania
- 5051. Emmaus, Borough of, Pennsylvania
- 5052. Ephrata, Borough of, Pennsylvania
- 5053. Ephrata, Township of, Pennsylvania
- 5054. Erie, City of, Pennsylvania
- 5055. Erie, County of, Pennsylvania
- 5056. Exeter, Township of, Pennsylvania
- 5057. Fairview, Township of, Pennsylvania



- 5058. Falls, Township of, Pennsylvania
- 5059. Fayette, County of, Pennsylvania
- 5060. Ferguson, Township of,  
Pennsylvania
- 5061. Forks, Township of, Pennsylvania
- 5062. Franconia, Township of,  
Pennsylvania
- 5063. Franklin, County of, Pennsylvania
- 5064. Franklin Park, Borough of,  
Pennsylvania
- 5065. Fulton, County of, Pennsylvania
- 5066. Greene, County of, Pennsylvania
- 5067. Greene, Township of, Pennsylvania
- 5068. Greensburg, City of, Pennsylvania
- 5069. Guilford, Township of, Pennsylvania
- 5070. Hamilton, Township of,  
Pennsylvania
- 5071. Hampden, Township of,  
Pennsylvania
- 5072. Hampton, Township of,  
Pennsylvania
- 5073. Hanover, Borough of, Pennsylvania
- 5074. Hanover, Township of, Pennsylvania
- 5075. Harborecreek, Township of,  
Pennsylvania
- 5076. Harrisburg, City of, Pennsylvania
- 5077. Harrison, Township of, Pennsylvania
- 5078. Hatfield, Township of, Pennsylvania
- 5079. Haverford, Township of,  
Pennsylvania
- 5080. Hazleton, City of, Pennsylvania
- 5081. Hempfield, Township of,  
Pennsylvania
- 5082. Hermitage, City of, Pennsylvania
- 5083. Hilltown, Township of, Pennsylvania
- 5084. Hopewell, Township of,  
Pennsylvania
- 5085. Horsham, Township of,  
Pennsylvania
- 5086. Huntingdon, County of,  
Pennsylvania
- 5087. Indiana, Borough of, Pennsylvania
- 5088. Indiana, County of, Pennsylvania
- 5089. Jefferson, County of, Pennsylvania
- 5090. Jefferson Hills, Borough of,  
Pennsylvania
- 5091. Johnstown, City of, Pennsylvania
- 5092. Juniata, County of, Pennsylvania
- 5093. Kingston, Borough of, Pennsylvania
- 5094. Lackawanna, County of,  
Pennsylvania
- 5095. Lancaster, City of, Pennsylvania
- 5096. Lancaster, County of, Pennsylvania
- 5097. Lancaster, Township of,  
Pennsylvania
- 5098. Lansdale, Borough of, Pennsylvania
- 5099. Lansdowne, Borough of,  
Pennsylvania
- 5100. Lawrence, County of, Pennsylvania
- 5101. Lebanon, City of, Pennsylvania
- 5102. Lebanon, County of, Pennsylvania
- 5103. Lehigh, County of, Pennsylvania
- 5104. Lehigh, Township of, Pennsylvania
- 5105. Lehman, Township of, Pennsylvania
- 5106. Limerick, Township of,  
Pennsylvania
- 5107. Logan, Township of, Pennsylvania
- 5108. Lower Allen, Township of,  
Pennsylvania
- 5109. Lower Burrell, City of, Pennsylvania
- 5110. Lower Gwynedd, Township of,  
Pennsylvania
- 5111. Lower Macungie, Township of,  
Pennsylvania
- 5112. Lower Makefield, Township of,  
Pennsylvania
- 5113. Lower Merion, Township of,  
Pennsylvania
- 5114. Lower Moreland, Township of,  
Pennsylvania
- 5115. Lower Paxton, Township of,  
Pennsylvania
- 5116. Lower Pottsgrove, Township of,  
Pennsylvania
- 5117. Lower Providence, Township of,  
Pennsylvania
- 5118. Lower Salford, Township of,  
Pennsylvania
- 5119. Lower Saucon, Township of,  
Pennsylvania
- 5120. Lower Southampton, Township of,  
Pennsylvania

- 5121. Loyalsock, Township of, Pennsylvania
- 5122. Luzerne, County of, Pennsylvania
- 5123. Lycoming, County of, Pennsylvania
- 5124. Manchester, Township of, Pennsylvania
- 5125. Manheim, Township of, Pennsylvania
- 5126. Manor, Township of, Pennsylvania
- 5127. Marple, Township of, Pennsylvania
- 5128. McCandless, Township of, Pennsylvania
- 5129. McKean, County of, Pennsylvania
- 5130. McKeesport, City of, Pennsylvania
- 5131. Meadville, City of, Pennsylvania
- 5132. Mercer, County of, Pennsylvania
- 5133. Middle Smithfield, Township of, Pennsylvania
- 5134. Middletown, Township of, Pennsylvania
- 5135. Mifflin, County of, Pennsylvania
- 5136. Milford, Township of, Pennsylvania
- 5137. Millcreek, Township of, Pennsylvania
- 5138. Monroe, County of, Pennsylvania
- 5139. Monroeville, Municipality of, Pennsylvania
- 5140. Montgomery, County of, Pennsylvania
- 5141. Montgomery, Township of, Pennsylvania
- 5142. Montour, County of, Pennsylvania
- 5143. Moon, Township of, Pennsylvania
- 5144. Mount Joy, Township of, Pennsylvania
- 5145. Mount Lebanon, Township of, Pennsylvania
- 5146. Mount Pleasant, Township of, Pennsylvania
- 5147. Muhlenberg, Township of, Pennsylvania
- 5148. Munhall, Borough of, Pennsylvania
- 5149. Murrysville, Municipality of, Pennsylvania
- 5150. Nanticoke, City of, Pennsylvania
- 5151. Nether Providence, Township of, Pennsylvania
- 5152. New Britain, Township of, Pennsylvania
- 5153. New Castle, City of, Pennsylvania
- 5154. New Garden, Township of, Pennsylvania
- 5155. New Hanover, Township of, Pennsylvania
- 5156. New Kensington, City of, Pennsylvania
- 5157. Newberry, Township of, Pennsylvania
- 5158. Newtown, Township of, Pennsylvania
- 5159. Norristown, Borough of, Pennsylvania
- 5160. North Fayette, Township of, Pennsylvania
- 5161. North Huntingdon, Township of, Pennsylvania
- 5162. North Lebanon, Township of, Pennsylvania
- 5163. North Middleton, Township of, Pennsylvania
- 5164. North Strabane, Township of, Pennsylvania
- 5165. North Union, Township of, Pennsylvania
- 5166. North Whitehall, Township of, Pennsylvania
- 5167. Northampton, County of, Pennsylvania
- 5168. Northampton, Township of, Pennsylvania
- 5169. Northumberland, County of, Pennsylvania
- 5170. Palmer, Township of, Pennsylvania
- 5171. Patton, Township of, Pennsylvania
- 5172. Penn Hills, Township of, Pennsylvania
- 5173. Penn, Township of, Pennsylvania
- 5174. Perry, County of, Pennsylvania
- 5175. Peters, Township of, Pennsylvania
- 5176. Philadelphia, City of/ County of, Pennsylvania

- 5177. Phoenixville, Borough of, Pennsylvania
- 5178. Pike, County of, Pennsylvania
- 5179. Pine, Township of, Pennsylvania
- 5180. Pittsburgh, City of, Pennsylvania
- 5181. Plum, Borough of, Pennsylvania
- 5182. Plumstead, Township of, Pennsylvania
- 5183. Plymouth, Township of, Pennsylvania
- 5184. Pocono, Township of, Pennsylvania
- 5185. Potter, County of, Pennsylvania
- 5186. Pottstown, Borough of, Pennsylvania
- 5187. Pottsville, City of, Pennsylvania
- 5188. Radnor, Township of, Pennsylvania
- 5189. Rapho, Township of, Pennsylvania
- 5190. Reading, City of, Pennsylvania
- 5191. Richland, Township of, Pennsylvania
- 5192. Ridley, Township of, Pennsylvania
- 5193. Robinson, Township of, Pennsylvania
- 5194. Ross, Township of, Pennsylvania
- 5195. Rostraver, Township of, Pennsylvania
- 5196. Salisbury, Township of, Pennsylvania
- 5197. Sandy, Township of, Pennsylvania
- 5198. Schuylkill, County of, Pennsylvania
- 5199. Scott, Township of, Pennsylvania
- 5200. Scranton, City of, Pennsylvania
- 5201. Shaler, Township of, Pennsylvania
- 5202. Sharon, City of, Pennsylvania
- 5203. Silver Spring, Township of, Pennsylvania
- 5204. Skippack, Township of, Pennsylvania
- 5205. Snyder, County of, Pennsylvania
- 5206. Somerset, County of, Pennsylvania
- 5207. Somerset, Township of, Pennsylvania
- 5208. South Fayette, Township of, Pennsylvania
- 5209. South Lebanon, Township of, Pennsylvania
- 5210. South Middleton, Township of, Pennsylvania
- 5211. South Park, Township of, Pennsylvania
- 5212. South Union, Township of, Pennsylvania
- 5213. South Whitehall, Township of, Pennsylvania
- 5214. Spring Garden, Township of, Pennsylvania
- 5215. Spring, Township of, Pennsylvania
- 5216. Springettsbury, Township of, Pennsylvania
- 5217. Springfield, Township of, Pennsylvania
- 5218. St. Marys, City of, Pennsylvania
- 5219. State College, Borough of, Pennsylvania
- 5220. Stroud, Township of, Pennsylvania
- 5221. Susquehanna, County of, Pennsylvania
- 5222. Susquehanna, Township of, Pennsylvania
- 5223. Swatara, Township of, Pennsylvania
- 5224. Tioga, County of, Pennsylvania
- 5225. Towamencin, Township of, Pennsylvania
- 5226. Tredyffrin, Township of, Pennsylvania
- 5227. Union, County of, Pennsylvania
- 5228. Unity, Township of, Pennsylvania
- 5229. Upper Allen, Township of, Pennsylvania
- 5230. Upper Chichester, Township of, Pennsylvania
- 5231. Upper Darby, Township of, Pennsylvania
- 5232. Upper Dublin, Township of, Pennsylvania
- 5233. Upper Gwynedd, Township of, Pennsylvania
- 5234. Upper Macungie, Township of, Pennsylvania
- 5235. Upper Merion, Township of, Pennsylvania

- 5236. Upper Moreland, Township of, Pennsylvania
- 5237. Upper Providence, Township of, Pennsylvania
- 5238. Upper Saucon, Township of, Pennsylvania
- 5239. Upper Southampton, Township of, Pennsylvania
- 5240. Upper St. Clair, Township of, Pennsylvania
- 5241. Upper Uwchlan, Township of, Pennsylvania
- 5242. Uwchlan, Township of, Pennsylvania
- 5243. Venango, County of, Pennsylvania
- 5244. Warminster, Township of, Pennsylvania
- 5245. Warren, County of, Pennsylvania
- 5246. Warrington, Township of, Pennsylvania
- 5247. Warwick, Township of, Pennsylvania
- 5248. Washington, City of, Pennsylvania
- 5249. Washington, County of, Pennsylvania
- 5250. Washington, Township of, Pennsylvania
- 5251. Wayne, County of, Pennsylvania
- 5252. Waynesboro, Borough of, Pennsylvania
- 5253. West Bradford, Township of, Pennsylvania
- 5254. West Chester, Borough of, Pennsylvania
- 5255. West Deer, Township of, Pennsylvania
- 5256. West Goshen, Township of, Pennsylvania
- 5257. West Hanover, Township of, Pennsylvania
- 5258. West Hempfield, Township of, Pennsylvania
- 5259. West Lampeter, Township of, Pennsylvania
- 5260. West Manchester, Township of, Pennsylvania
- 5261. West Mifflin, Borough of, Pennsylvania
- 5262. West Norriton, Township of, Pennsylvania
- 5263. West Whiteland, Township of, Pennsylvania
- 5264. Westmoreland, County of, Pennsylvania
- 5265. Westtown, Township of, Pennsylvania
- 5266. White, Township of, Pennsylvania
- 5267. Whitehall, Borough of, Pennsylvania
- 5268. Whitehall, Township of, Pennsylvania
- 5269. Whitemarsh, Township of, Pennsylvania
- 5270. Whitpain, Township of, Pennsylvania
- 5271. Wilkes-Barre, City of, Pennsylvania
- 5272. Wilkinsburg, Borough of, Pennsylvania
- 5273. Williamsport, City of, Pennsylvania
- 5274. Willistown, Township of, Pennsylvania
- 5275. Windsor, Township of, Pennsylvania
- 5276. Worcester, Township of, Pennsylvania
- 5277. Wyoming, County of, Pennsylvania
- 5278. Wyomissing, Borough of, Pennsylvania
- 5279. Yeadon, Borough of, Pennsylvania
- 5280. York, City of, Pennsylvania
- 5281. York, County of, Pennsylvania
- 5282. York, Township of, Pennsylvania
- 5283. Adjuntas, Municipality of, Puerto Rico
- 5284. Aguada, Municipality of, Puerto Rico
- 5285. Aguadilla, Municipality of, Puerto Rico
- 5286. Aguas Buenas, Municipality of, Puerto Rico
- 5287. Aibonito, Municipality of, Puerto Rico
- 5288. Añasco, Municipality of, Puerto Rico

5289. Arecibo, Municipality of, Puerto Rico
5290. Arroyo, Municipality of, Puerto Rico
5291. Barceloneta, Municipality of, Puerto Rico
5292. Barranquitas, Municipality of, Puerto Rico
5293. Bayamón, Municipality of, Puerto Rico
5294. Cabo Rojo, Municipality of, Puerto Rico
5295. Caguas, Municipality of, Puerto Rico
5296. Camuy, Municipality of, Puerto Rico
5297. Canóvanas, Municipality of, Puerto Rico
5298. Carolina, Municipality of, Puerto Rico
5299. Cataño, Municipality of, Puerto Rico
5300. Cayey, Municipality of, Puerto Rico
5301. Ceiba, Municipality of, Puerto Rico
5302. Ciales, Municipality of, Puerto Rico
5303. Cidra, Municipality of, Puerto Rico
5304. Coamo, Municipality of, Puerto Rico
5305. Comerío, Municipality of, Puerto Rico
5306. Corozal, Municipality of, Puerto Rico
5307. Dorado, Municipality of, Puerto Rico
5308. Fajardo, Municipality of, Puerto Rico
5309. Florida, Municipality of, Puerto Rico
5310. Guánica, Municipality of, Puerto Rico
5311. Guayama, Municipality of, Puerto Rico
5312. Guayanilla, Municipality of, Puerto Rico
5313. Guaynabo, Municipality of, Puerto Rico
5314. Gurabo, Municipality of, Puerto Rico
5315. Hatillo, Municipality of, Puerto Rico
5316. Hormigueros, Municipality of, Puerto Rico
5317. Humacao, Municipality of, Puerto Rico
5318. Isabela, Municipality of, Puerto Rico
5319. Jayuya, Municipality of, Puerto Rico
5320. Juana Díaz, Municipality of, Puerto Rico
5321. Juncos, Municipality of, Puerto Rico
5322. Lajas, Municipality of, Puerto Rico
5323. Lares, Municipality of, Puerto Rico
5324. Las Piedras, Municipality of, Puerto Rico
5325. Loíza, Municipality of, Puerto Rico
5326. Luquillo, Municipality of, Puerto Rico
5327. Manatí, Municipality of, Puerto Rico
5328. Maunabo, Municipality of, Puerto Rico
5329. Mayagüez, Municipality of, Puerto Rico
5330. Moca, Municipality of, Puerto Rico
5331. Morovis, Municipality of, Puerto Rico
5332. Naguabo, Municipality of, Puerto Rico
5333. Naranjito, Municipality of, Puerto Rico
5334. Orocovis, Municipality of, Puerto Rico
5335. Patillas, Municipality of, Puerto Rico
5336. Peñuelas, Municipality of, Puerto Rico
5337. Ponce, Municipality of, Puerto Rico
5338. Quebradillas, Municipality of, Puerto Rico
5339. Rincón, Municipality of, Puerto Rico
5340. Río Grande, Municipality of, Puerto Rico
5341. Sabana Grande, Municipality of, Puerto Rico
5342. Salinas, Municipality of, Puerto Rico
5343. San Germán, Municipality of, Puerto Rico
5344. San Juan, Municipality of, Puerto Rico
5345. San Lorenzo, Municipality of, Puerto Rico
5346. San Sebastián, Municipality of, Puerto Rico

- 5347. Santa Isabel, Municipality of, Puerto Rico
- 5348. Toa Alta, Municipality of, Puerto Rico
- 5349. Toa Baja, Municipality of, Puerto Rico
- 5350. Trujillo Alto, Municipality of, Puerto Rico
- 5351. Utuado, Municipality of, Puerto Rico
- 5352. Vega Alta, Municipality of, Puerto Rico
- 5353. Vega Baja, Municipality of, Puerto Rico
- 5354. Villalba, Municipality of, Puerto Rico
- 5355. Yabucoa, Municipality of, Puerto Rico
- 5356. Yauco, Municipality of, Puerto Rico
- 5357. Barrington, Town of, Rhode Island
- 5358. Bristol, Town of, Rhode Island
- 5359. Burrillville, Town of, Rhode Island
- 5360. Central Falls, City of, Rhode Island
- 5361. Coventry, Town of, Rhode Island
- 5362. Cranston, City of, Rhode Island
- 5363. Cumberland, Town of, Rhode Island
- 5364. East Greenwich, Town of, Rhode Island
- 5365. East Providence, City of, Rhode Island
- 5366. Glocester, Town of, Rhode Island
- 5367. Johnston, Town of, Rhode Island
- 5368. Lincoln, Town of, Rhode Island
- 5369. Middletown, Town of, Rhode Island
- 5370. Narragansett, Town of, Rhode Island
- 5371. Newport, City of, Rhode Island
- 5372. North Kingstown, Town of, Rhode Island
- 5373. North Providence, Town of, Rhode Island
- 5374. North Smithfield, Town of, Rhode Island
- 5375. Pawtucket, City of, Rhode Island
- 5376. Portsmouth, Town of, Rhode Island
- 5377. Providence, City of, Rhode Island
- 5378. Scituate, Town of, Rhode Island
- 5379. Smithfield, Town of, Rhode Island
- 5380. South Kingstown, Town of, Rhode Island
- 5381. Tiverton, Town of, Rhode Island
- 5382. Warren, Town of, Rhode Island
- 5383. Warwick, City of, Rhode Island
- 5384. West Warwick, Town of, Rhode Island
- 5385. Westerly, Town of, Rhode Island
- 5386. Woonsocket, City of, Rhode Island
- 5387. Abbeville, County of, South Carolina
- 5388. Aiken, City of, South Carolina
- 5389. Aiken, County of, South Carolina
- 5390. Anderson, City of, South Carolina
- 5391. Anderson, County of, South Carolina
- 5392. Bamberg, County of, South Carolina
- 5393. Barnwell, County of, South Carolina
- 5394. Beaufort, City of, South Carolina
- 5395. Beaufort, County of, South Carolina
- 5396. Berkeley, County of, South Carolina
- 5397. Bluffton, Town of, South Carolina
- 5398. Calhoun, County of, South Carolina
- 5399. Cayce, City of, South Carolina
- 5400. Charleston, City of, South Carolina
- 5401. Charleston, County of, South Carolina
- 5402. Cherokee, County of, South Carolina
- 5403. Chester, County of, South Carolina
- 5404. Chesterfield, County of, South Carolina
- 5405. Clarendon, County of, South Carolina
- 5406. Clemson, City of, South Carolina
- 5407. Colleton, County of, South Carolina
- 5408. Columbia, City of, South Carolina
- 5409. Conway, City of, South Carolina
- 5410. Darlington, County of, South Carolina
- 5411. Dillon, County of, South Carolina
- 5412. Dorchester, County of, South Carolina
- 5413. Easley, City of, South Carolina
- 5414. Edgefield, County of, South Carolina
- 5415. Fairfield, County of, South Carolina
- 5416. Florence, City of, South Carolina
- 5417. Florence, County of, South Carolina
- 5418. Forest Acres, City of, South Carolina

- 5419. Fort Mill, Town of, South Carolina
- 5420. Fountain Inn, City of, South Carolina
- 5421. Gaffney, City of, South Carolina
- 5422. Georgetown, County of, South Carolina
- 5423. Goose Creek, City of, South Carolina
- 5424. Greenville, City of, South Carolina
- 5425. Greenville, County of, South Carolina
- 5426. Greenwood, City of, South Carolina
- 5427. Greenwood, County of, South Carolina
- 5428. Greer, City of, South Carolina
- 5429. Hampton, County of, South Carolina
- 5430. Hanahan, City of, South Carolina
- 5431. Hilton Head Island, Town of, South Carolina
- 5432. Horry, County of, South Carolina
- 5433. Irmo, Town of, South Carolina
- 5434. James Island, Town of, South Carolina
- 5435. Jasper, County of, South Carolina
- 5436. Kershaw, County of, South Carolina
- 5437. Lancaster, County of, South Carolina
- 5438. Laurens, County of, South Carolina
- 5439. Lee, County of, South Carolina
- 5440. Lexington, County of, South Carolina
- 5441. Lexington, Town of, South Carolina
- 5442. Marion, County of, South Carolina
- 5443. Marlboro, County of, South Carolina
- 5444. Mauldin, City of, South Carolina
- 5445. Moncks Corner, Town of, South Carolina
- 5446. Mount Pleasant, Town of, South Carolina
- 5447. Myrtle Beach, City of, South Carolina
- 5448. Newberry, City of, South Carolina
- 5449. Newberry, County of, South Carolina
- 5450. North Augusta, City of, South Carolina
- 5451. North Charleston, City of, South Carolina
- 5452. North Myrtle Beach, City of, South Carolina
- 5453. Oconee, County of, South Carolina
- 5454. Orangeburg, City of, South Carolina
- 5455. Orangeburg, County of, South Carolina
- 5456. Pickens, County of, South Carolina
- 5457. Port Royal, Town of, South Carolina
- 5458. Richland, County of, South Carolina
- 5459. Rock Hill, City of, South Carolina
- 5460. Saluda, County of, South Carolina
- 5461. Simpsonville, City of, South Carolina
- 5462. Spartanburg, City of, South Carolina
- 5463. Spartanburg, County of, South Carolina
- 5464. Summerville, Town of, South Carolina
- 5465. Sumter, City of, South Carolina
- 5466. Sumter, County of, South Carolina
- 5467. Tega Cay, City of, South Carolina
- 5468. Union, County of, South Carolina
- 5469. West Columbia, City of, South Carolina
- 5470. Williamsburg, County of, South Carolina
- 5471. York, County of, South Carolina
- 5472. Aberdeen, City of, South Dakota
- 5473. Beadle, County of, South Dakota
- 5474. Box Elder, City of, South Dakota
- 5475. Brandon, City of, South Dakota
- 5476. Brookings, City of, South Dakota
- 5477. Brookings, County of, South Dakota
- 5478. Brown, County of, South Dakota
- 5479. Butte, County of, South Dakota
- 5480. Clay, County of, South Dakota
- 5481. Codington, County of, South Dakota
- 5482. Davison, County of, South Dakota
- 5483. Hughes, County of, South Dakota
- 5484. Huron, City of, South Dakota
- 5485. Lake, County of, South Dakota
- 5486. Lawrence, County of, South Dakota
- 5487. Lincoln, County of, South Dakota
- 5488. Meade, County of, South Dakota
- 5489. Minnehaha, County of, South Dakota
- 5490. Mitchell, City of, South Dakota

- 5491. Oglala Lakota, County of, South Dakota
- 5492. Pennington, County of, South Dakota
- 5493. Pierre, City of, South Dakota
- 5494. Rapid City, City of, South Dakota
- 5495. Roberts, County of, South Dakota
- 5496. Sioux Falls, City of, South Dakota
- 5497. Spearfish, City of, South Dakota
- 5498. Todd, County of, South Dakota
- 5499. Union, County of, South Dakota
- 5500. Vermillion, City of, South Dakota
- 5501. Watertown, City of, South Dakota
- 5502. Yankton, City of, South Dakota
- 5503. Yankton, County of, South Dakota
- 5504. Anderson, County of, Tennessee
- 5505. Arlington, Town of, Tennessee
- 5506. Athens, City of, Tennessee
- 5507. Bartlett, City of, Tennessee
- 5508. Bedford, County of, Tennessee
- 5509. Benton, County of, Tennessee
- 5510. Bledsoe, County of, Tennessee
- 5511. Blount, County of, Tennessee
- 5512. Bradley, County of, Tennessee
- 5513. Brentwood, City of, Tennessee
- 5514. Bristol, City of, Tennessee
- 5515. Campbell, County of, Tennessee
- 5516. Cannon, County of, Tennessee
- 5517. Carroll, County of, Tennessee
- 5518. Carter, County of, Tennessee
- 5519. Chattanooga, City of, Tennessee
- 5520. Cheatham, County of, Tennessee
- 5521. Chester, County of, Tennessee
- 5522. Claiborne, County of, Tennessee
- 5523. Clarksville, City of, Tennessee
- 5524. Cleveland, City of, Tennessee
- 5525. Clinton, City of, Tennessee
- 5526. Cocke, County of, Tennessee
- 5527. Coffee, County of, Tennessee
- 5528. Collegedale, City of, Tennessee
- 5529. Collierville, Town of, Tennessee
- 5530. Columbia, City of, Tennessee
- 5531. Cookeville, City of, Tennessee
- 5532. Crockett, County of, Tennessee
- 5533. Crossville, City of, Tennessee
- 5534. Cumberland, County of, Tennessee
- 5535. Decatur, County of, Tennessee
- 5536. DeKalb, County of, Tennessee
- 5537. Dickson, City of, Tennessee
- 5538. Dickson, County of, Tennessee
- 5539. Dyer, County of, Tennessee
- 5540. Dyersburg, City of, Tennessee
- 5541. East Ridge, City of, Tennessee
- 5542. Elizabethton, City of, Tennessee
- 5543. Farragut, Town of, Tennessee
- 5544. Fayette, County of, Tennessee
- 5545. Fentress, County of, Tennessee
- 5546. Franklin, City of, Tennessee
- 5547. Franklin, County of, Tennessee
- 5548. Gallatin, City of, Tennessee
- 5549. Germantown, City of, Tennessee
- 5550. Gibson, County of, Tennessee
- 5551. Giles, County of, Tennessee
- 5552. Goodlettsville, City of, Tennessee
- 5553. Grainger, County of, Tennessee
- 5554. Greene, County of, Tennessee
- 5555. Greeneville, Town of, Tennessee
- 5556. Grundy, County of, Tennessee
- 5557. Hamblen, County of, Tennessee
- 5558. Hamilton, County of, Tennessee
- 5559. Hardeman, County of, Tennessee
- 5560. Hardin, County of, Tennessee
- 5561. Hartsville/Trousdale, County of, Tennessee
- 5562. Hawkins, County of, Tennessee
- 5563. Haywood, County of, Tennessee
- 5564. Henderson, County of, Tennessee
- 5565. Hendersonville, City of, Tennessee
- 5566. Henry, County of, Tennessee
- 5567. Hickman, County of, Tennessee
- 5568. Humphreys, County of, Tennessee
- 5569. Jackson, City of, Tennessee
- 5570. Jackson, County of, Tennessee
- 5571. Jefferson, County of, Tennessee
- 5572. Johnson City, City of, Tennessee
- 5573. Johnson, County of, Tennessee
- 5574. Kingsport, City of, Tennessee
- 5575. Knox, County of, Tennessee
- 5576. Knoxville, City of, Tennessee
- 5577. La Vergne, City of, Tennessee
- 5578. Lakeland, City of, Tennessee
- 5579. Lauderdale, County of, Tennessee



- 5580. Lawrence, County of, Tennessee
- 5581. Lawrenceburg, City of, Tennessee
- 5582. Lebanon, City of, Tennessee
- 5583. Lewis, County of, Tennessee
- 5584. Lewisburg, City of, Tennessee
- 5585. Lincoln, County of, Tennessee
- 5586. Loudon, County of, Tennessee
- 5587. Macon, County of, Tennessee
- 5588. Madison, County of, Tennessee
- 5589. Manchester, City of, Tennessee
- 5590. Marion, County of, Tennessee
- 5591. Marshall, County of, Tennessee
- 5592. Martin, City of, Tennessee
- 5593. Maryville, City of, Tennessee
- 5594. Maury, County of, Tennessee
- 5595. McMinn, County of, Tennessee
- 5596. McMinnville, City of, Tennessee
- 5597. McNairy, County of, Tennessee
- 5598. Meigs, County of, Tennessee
- 5599. Memphis, City of, Tennessee
- 5600. Millington, City of, Tennessee
- 5601. Monroe, County of, Tennessee
- 5602. Montgomery, County of, Tennessee
- 5603. Morgan, County of, Tennessee
- 5604. Morristown, City of, Tennessee
- 5605. Mount Juliet, City of, Tennessee
- 5606. Murfreesboro, City of, Tennessee
- 5607. Nashville-Davidson, Metropolitan Government, Tennessee
- 5608. Nolensville, Town of, Tennessee
- 5609. Oak Ridge, City of, Tennessee
- 5610. Obion, County of, Tennessee
- 5611. Overton, County of, Tennessee
- 5612. Paris, City of, Tennessee
- 5613. Polk, County of, Tennessee
- 5614. Portland, City of, Tennessee
- 5615. Putnam, County of, Tennessee
- 5616. Red Bank, City of, Tennessee
- 5617. Rhea, County of, Tennessee
- 5618. Roane, County of, Tennessee
- 5619. Robertson, County of, Tennessee
- 5620. Rutherford, County of, Tennessee
- 5621. Scott, County of, Tennessee
- 5622. Sequatchie, County of, Tennessee
- 5623. Sevier, County of, Tennessee
- 5624. Sevierville, City of, Tennessee
- 5625. Shelby, County of, Tennessee
- 5626. Shelbyville, City of, Tennessee
- 5627. Smith, County of, Tennessee
- 5628. Smyrna, Town of, Tennessee
- 5629. Soddy-Daisy, City of, Tennessee
- 5630. Spring Hill, City of, Tennessee
- 5631. Springfield, City of, Tennessee
- 5632. Stewart, County of, Tennessee
- 5633. Sullivan, County of, Tennessee
- 5634. Sumner, County of, Tennessee
- 5635. Tipton, County of, Tennessee
- 5636. Tullahoma, City of, Tennessee
- 5637. Unicoi, County of, Tennessee
- 5638. Union City, City of, Tennessee
- 5639. Union, County of, Tennessee
- 5640. Warren, County of, Tennessee
- 5641. Washington, County of, Tennessee
- 5642. Wayne, County of, Tennessee
- 5643. Weakley, County of, Tennessee
- 5644. White, County of, Tennessee
- 5645. White House, City of, Tennessee
- 5646. Williamson, County of, Tennessee
- 5647. Wilson, County of, Tennessee
- 5648. Abilene, City of, Texas
- 5649. Addison, Town of, Texas
- 5650. Alamo, City of, Texas
- 5651. Alice, City of, Texas
- 5652. Allen, City of, Texas
- 5653. Alton, City of, Texas
- 5654. Alvin, City of, Texas
- 5655. Amarillo, City of, Texas
- 5656. Anderson, County of, Texas
- 5657. Andrews, City of, Texas
- 5658. Andrews, County of, Texas
- 5659. Angelina, County of, Texas
- 5660. Angleton, City of, Texas
- 5661. Anna, City of, Texas
- 5662. Aransas, County of, Texas
- 5663. Arlington, City of, Texas
- 5664. Atascosa, County of, Texas
- 5665. Athens, City of, Texas
- 5666. Austin, City of, Texas
- 5667. Austin, County of, Texas
- 5668. Azle, City of, Texas
- 5669. Balch Springs, City of, Texas
- 5670. Bandera, County of, Texas

- 5671. Bastrop, County of, Texas
- 5672. Bay City, City of, Texas
- 5673. Baytown, City of, Texas
- 5674. Beaumont, City of, Texas
- 5675. Bedford, City of, Texas
- 5676. Bee, County of, Texas
- 5677. Beeville, City of, Texas
- 5678. Bell, County of, Texas
- 5679. Bellaire, City of, Texas
- 5680. Bellmead, City of, Texas
- 5681. Belton, City of, Texas
- 5682. Benbrook, City of, Texas
- 5683. Bexar, County of, Texas
- 5684. Big Spring, City of, Texas
- 5685. Blanco, County of, Texas
- 5686. Boerne, City of, Texas
- 5687. Bonham, City of, Texas
- 5688. Borger, City of, Texas
- 5689. Bosque, County of, Texas
- 5690. Bowie, County of, Texas
- 5691. Brazoria, County of, Texas
- 5692. Brazos, County of, Texas
- 5693. Brenham, City of, Texas
- 5694. Brown, County of, Texas
- 5695. Brownsville, City of, Texas
- 5696. Brownwood, City of, Texas
- 5697. Bryan, City of, Texas
- 5698. Buda, City of, Texas
- 5699. Burkburnett, City of, Texas
- 5700. Burleson, City of, Texas
- 5701. Burleson, County of, Texas
- 5702. Burnet, County of, Texas
- 5703. Caldwell, County of, Texas
- 5704. Calhoun, County of, Texas
- 5705. Callahan, County of, Texas
- 5706. Cameron, County of, Texas
- 5707. Camp, County of, Texas
- 5708. Canyon, City of, Texas
- 5709. Carrollton, City of, Texas
- 5710. Cass, County of, Texas
- 5711. Cedar Hill, City of, Texas
- 5712. Cedar Park, City of, Texas
- 5713. Celina, City of, Texas
- 5714. Chambers, County of, Texas
- 5715. Cherokee, County of, Texas
- 5716. Cibolo, City of, Texas
- 5717. Clay, County of, Texas
- 5718. Cleburne, City of, Texas
- 5719. Clute, City of, Texas
- 5720. College Station, City of, Texas
- 5721. Colleyville, City of, Texas
- 5722. Collin, County of, Texas
- 5723. Colorado, County of, Texas
- 5724. Comal, County of, Texas
- 5725. Comanche, County of, Texas
- 5726. Conroe, City of, Texas
- 5727. Converse, City of, Texas
- 5728. Cooke, County of, Texas
- 5729. Coppell, City of, Texas
- 5730. Copperas Cove, City of, Texas
- 5731. Corinth, City of, Texas
- 5732. Corpus Christi, City of, Texas
- 5733. Corsicana, City of, Texas
- 5734. Coryell, County of, Texas
- 5735. Crowley, City of, Texas
- 5736. Dallas, City of, Texas
- 5737. Dallas, County of, Texas
- 5738. Dawson, County of, Texas
- 5739. Deaf Smith, County of, Texas
- 5740. Deer Park, City of, Texas
- 5741. Del Rio, City of, Texas
- 5742. Denison, City of, Texas
- 5743. Denton, City of, Texas
- 5744. Denton, County of, Texas
- 5745. DeSoto, City of, Texas
- 5746. DeWitt, County of, Texas
- 5747. Dickinson, City of, Texas
- 5748. Dimmit, County of, Texas
- 5749. Donna, City of, Texas
- 5750. Dumas, City of, Texas
- 5751. Duncanville, City of, Texas
- 5752. Duval, County of, Texas
- 5753. Eagle Pass, City of, Texas
- 5754. Eastland, County of, Texas
- 5755. Ector, County of, Texas
- 5756. Edinburg, City of, Texas
- 5757. El Campo, City of, Texas
- 5758. El Paso, City of, Texas
- 5759. El Paso, County of, Texas
- 5760. Elgin, City of, Texas
- 5761. Ellis, County of, Texas
- 5762. Ennis, City of, Texas

- 5763. Erath, County of, Texas
- 5764. Eules, City of, Texas
- 5765. Fair Oaks Ranch, City of, Texas
- 5766. Falls, County of, Texas
- 5767. Fannin, County of, Texas
- 5768. Farmers Branch, City of, Texas
- 5769. Fate, City of, Texas
- 5770. Fayette, County of, Texas
- 5771. Flower Mound, Town of, Texas
- 5772. Forest Hill, City of, Texas
- 5773. Forney, City of, Texas
- 5774. Fort Bend, County of, Texas
- 5775. Fort Worth, City of, Texas
- 5776. Franklin, County of, Texas
- 5777. Fredericksburg, City of, Texas
- 5778. Freeport, City of, Texas
- 5779. Freestone, County of, Texas
- 5780. Friendswood, City of, Texas
- 5781. Frio, County of, Texas
- 5782. Frisco, City of, Texas
- 5783. Fulshear, City of, Texas
- 5784. Gaines, County of, Texas
- 5785. Gainesville, City of, Texas
- 5786. Galena Park, City of, Texas
- 5787. Galveston, City of, Texas
- 5788. Galveston, County of, Texas
- 5789. Garland, City of, Texas
- 5790. Gatesville, City of, Texas
- 5791. Georgetown, City of, Texas
- 5792. Gillespie, County of, Texas
- 5793. Glenn Heights, City of, Texas
- 5794. Gonzales, County of, Texas
- 5795. Granbury, City of, Texas
- 5796. Grand Prairie, City of, Texas
- 5797. Grapevine, City of, Texas
- 5798. Gray, County of, Texas
- 5799. Grayson, County of, Texas
- 5800. Greenville, City of, Texas
- 5801. Gregg, County of, Texas
- 5802. Grimes, County of, Texas
- 5803. Groves, City of, Texas
- 5804. Guadalupe, County of, Texas
- 5805. Hale, County of, Texas
- 5806. Haltom City, City of, Texas
- 5807. Hardin, County of, Texas
- 5808. Harker Heights, City of, Texas
- 5809. Harlingen, City of, Texas
- 5810. Harris, County of, Texas
- 5811. Harrison, County of, Texas
- 5812. Hays, County of, Texas
- 5813. Henderson, City of, Texas
- 5814. Henderson, County of, Texas
- 5815. Hereford, City of, Texas
- 5816. Hewitt, City of, Texas
- 5817. Hidalgo, City of, Texas
- 5818. Hidalgo, County of, Texas
- 5819. Highland, Village of, City of, Texas
- 5820. Hill, County of, Texas
- 5821. Hockley, County of, Texas
- 5822. Hood, County of, Texas
- 5823. Hopkins, County of, Texas
- 5824. Horizon City, City of, Texas
- 5825. Houston, City of, Texas
- 5826. Houston, County of, Texas
- 5827. Howard, County of, Texas
- 5828. Humble, City of, Texas
- 5829. Hunt, County of, Texas
- 5830. Huntsville, City of, Texas
- 5831. Hurst, City of, Texas
- 5832. Hutchinson, County of, Texas
- 5833. Hutto, City of, Texas
- 5834. Ingleside, City of, Texas
- 5835. Irving, City of, Texas
- 5836. Jacinto City, City of, Texas
- 5837. Jackson, County of, Texas
- 5838. Jacksonville, City of, Texas
- 5839. Jasper, County of, Texas
- 5840. Jefferson, County of, Texas
- 5841. Jim Wells, County of, Texas
- 5842. Johnson, County of, Texas
- 5843. Jones, County of, Texas
- 5844. Karnes, County of, Texas
- 5845. Katy, City of, Texas
- 5846. Kaufman, County of, Texas
- 5847. Keller, City of, Texas
- 5848. Kendall, County of, Texas
- 5849. Kerr, County of, Texas
- 5850. Kerrville, City of, Texas
- 5851. Kilgore, City of, Texas
- 5852. Killeen, City of, Texas
- 5853. Kingsville, City of, Texas
- 5854. Kleberg, County of, Texas

- 5855. Kyle, City of, Texas
- 5856. La Marque, City of, Texas
- 5857. La Porte, City of, Texas
- 5858. Lake Jackson, City of, Texas
- 5859. Lakeway, City of, Texas
- 5860. Lamar, County of, Texas
- 5861. Lamb, County of, Texas
- 5862. Lampasas, County of, Texas
- 5863. Lancaster, City of, Texas
- 5864. Laredo, City of, Texas
- 5865. Lavaca, County of, Texas
- 5866. League City, City of, Texas
- 5867. Leander, City of, Texas
- 5868. Lee, County of, Texas
- 5869. Leon, County of, Texas
- 5870. Leon Valley, City of, Texas
- 5871. Levelland, City of, Texas
- 5872. Lewisville, City of, Texas
- 5873. Liberty, County of, Texas
- 5874. Limestone, County of, Texas
- 5875. Little Elm, City of, Texas
- 5876. Live Oak, City of, Texas
- 5877. Live Oak, County of, Texas
- 5878. Llano, County of, Texas
- 5879. Lockhart, City of, Texas
- 5880. Longview, City of, Texas
- 5881. Lubbock, City of, Texas
- 5882. Lubbock, County of, Texas
- 5883. Lufkin, City of, Texas
- 5884. Lumberton, City of, Texas
- 5885. Madison, County of, Texas
- 5886. Manor, City of, Texas
- 5887. Mansfield, City of, Texas
- 5888. Manvel, City of, Texas
- 5889. Marshall, City of, Texas
- 5890. Matagorda, County of, Texas
- 5891. Maverick, County of, Texas
- 5892. McAllen, City of, Texas
- 5893. McKinney, City of, Texas
- 5894. McLennan, County of, Texas
- 5895. Medina, County of, Texas
- 5896. Melissa, City of, Texas
- 5897. Mercedes, City of, Texas
- 5898. Mesquite, City of, Texas
- 5899. Midland, City of, Texas
- 5900. Midland, County of, Texas
- 5901. Midlothian, City of, Texas
- 5902. Milam, County of, Texas
- 5903. Mineral Wells, City of, Texas
- 5904. Mission, City of, Texas
- 5905. Missouri City, City of, Texas
- 5906. Montague, County of, Texas
- 5907. Montgomery, County of, Texas
- 5908. Moore, County of, Texas
- 5909. Morris, County of, Texas
- 5910. Mount Pleasant, City of, Texas
- 5911. Murphy, City of, Texas
- 5912. Nacogdoches, City of, Texas
- 5913. Nacogdoches, County of, Texas
- 5914. Navarro, County of, Texas
- 5915. Nederland, City of, Texas
- 5916. New Braunfels, City of, Texas
- 5917. Newton, County of, Texas
- 5918. Nolan, County of, Texas
- 5919. North Richland Hills, City of, Texas
- 5920. Nueces, County of, Texas
- 5921. Odessa, City of, Texas
- 5922. Orange, City of, Texas
- 5923. Orange, County of, Texas
- 5924. Palestine, City of, Texas
- 5925. Palo Pinto, County of, Texas
- 5926. Pampa, City of, Texas
- 5927. Panola, County of, Texas
- 5928. Paris, City of, Texas
- 5929. Parker, County of, Texas
- 5930. Pasadena, City of, Texas
- 5931. Pearland, City of, Texas
- 5932. Pearsall, City of, Texas
- 5933. Pecos, City of, Texas
- 5934. Pecos, County of, Texas
- 5935. Pflugerville, City of, Texas
- 5936. Pharr, City of, Texas
- 5937. Plainview, City of, Texas
- 5938. Plano, City of, Texas
- 5939. Pleasanton, City of, Texas
- 5940. Polk, County of, Texas
- 5941. Port Arthur, City of, Texas
- 5942. Port Lavaca, City of, Texas
- 5943. Port Neches, City of, Texas
- 5944. Portland, City of, Texas
- 5945. Potter, County of, Texas
- 5946. Princeton, City of, Texas

- 5947. Prosper, Town of, Texas
- 5948. Rains, County of, Texas
- 5949. Randall, County of, Texas
- 5950. Raymondville, City of, Texas
- 5951. Red Oak, City of, Texas
- 5952. Red River, County of, Texas
- 5953. Reeves, County of, Texas
- 5954. Richardson, City of, Texas
- 5955. Richmond, City of, Texas
- 5956. Rio Grande City, City of, Texas
- 5957. Robertson, County of, Texas
- 5958. Robinson, City of, Texas
- 5959. Robstown, City of, Texas
- 5960. Rockport, City of, Texas
- 5961. Rockwall, City of, Texas
- 5962. Rockwall, County of, Texas
- 5963. Roma, City of, Texas
- 5964. Rosenberg, City of, Texas
- 5965. Round Rock, City of, Texas
- 5966. Rowlett, City of, Texas
- 5967. Royse City, City of, Texas
- 5968. Runnels, County of, Texas
- 5969. Rusk, County of, Texas
- 5970. Sabine, County of, Texas
- 5971. Sachse, City of, Texas
- 5972. Saginaw, City of, Texas
- 5973. San Angelo, City of, Texas
- 5974. San Antonio, City of, Texas
- 5975. San Benito, City of, Texas
- 5976. San Jacinto, County of, Texas
- 5977. San Juan, City of, Texas
- 5978. San Marcos, City of, Texas
- 5979. San Patricio, County of, Texas
- 5980. Santa Fe, City of, Texas
- 5981. Schertz, City of, Texas
- 5982. Scurry, County of, Texas
- 5983. Seabrook, City of, Texas
- 5984. Seagoville, City of, Texas
- 5985. Seguin, City of, Texas
- 5986. Selma, City of, Texas
- 5987. Shelby, County of, Texas
- 5988. Sherman, City of, Texas
- 5989. Smith, County of, Texas
- 5990. Snyder, City of, Texas
- 5991. Socorro, City of, Texas
- 5992. South Houston, City of, Texas
- 5993. Southlake, City of, Texas
- 5994. Stafford, City of, Texas
- 5995. Starr, County of, Texas
- 5996. Stephenville, City of, Texas
- 5997. Sugar Land, City of, Texas
- 5998. Sulphur Springs, City of, Texas
- 5999. Sweetwater, City of, Texas
- 6000. Tarrant, County of, Texas
- 6001. Taylor, City of, Texas
- 6002. Taylor, County of, Texas
- 6003. Temple, City of, Texas
- 6004. Terrell, City of, Texas
- 6005. Terry, County of, Texas
- 6006. Texarkana, City of, Texas
- 6007. Texas City, City of, Texas
- 6008. The Colony, City of, Texas
- 6009. Titus, County of, Texas
- 6010. Tom Green, County of, Texas
- 6011. Tomball, City of, Texas
- 6012. Travis, County of, Texas
- 6013. Trinity, County of, Texas
- 6014. Trophy Club, Town of, Texas
- 6015. Tyler, City of, Texas
- 6016. Tyler, County of, Texas
- 6017. Universal City, City of, Texas
- 6018. University Park, City of, Texas
- 6019. Upshur, County of, Texas
- 6020. Uvalde, City of, Texas
- 6021. Uvalde, County of, Texas
- 6022. Val Verde, County of, Texas
- 6023. Van Zandt, County of, Texas
- 6024. Vernon, City of, Texas
- 6025. Victoria, City of, Texas
- 6026. Victoria, County of, Texas
- 6027. Vidor, City of, Texas
- 6028. Waco, City of, Texas
- 6029. Walker, County of, Texas
- 6030. Waller, County of, Texas
- 6031. Ward, County of, Texas
- 6032. Washington, County of, Texas
- 6033. Watauga, City of, Texas
- 6034. Waxahachie, City of, Texas
- 6035. Weatherford, City of, Texas
- 6036. Webb, County of, Texas
- 6037. Webster, City of, Texas
- 6038. Weslaco, City of, Texas

- 6039. West University Place, City of, Texas
- 6040. Wharton, County of, Texas
- 6041. White Settlement, City of, Texas
- 6042. Wichita, County of, Texas
- 6043. Wichita Falls, City of, Texas
- 6044. Wilbarger, County of, Texas
- 6045. Willacy, County of, Texas
- 6046. Williamson, County of, Texas
- 6047. Wilson, County of, Texas
- 6048. Wise, County of, Texas
- 6049. Wood, County of, Texas
- 6050. Wylie, City of, Texas
- 6051. Young, County of, Texas
- 6052. Zapata, County of, Texas
- 6053. Zavala, County of, Texas
- 6054. Alpine, City of, Utah
- 6055. American Fork, City of, Utah
- 6056. Bluffdale, City of, Utah
- 6057. Bountiful, City of, Utah
- 6058. Box Elder, County of, Utah
- 6059. Brigham City, City of, Utah
- 6060. Cache, County of, Utah
- 6061. Carbon, County of, Utah
- 6062. Cedar City, City of, Utah
- 6063. Cedar Hills, City of, Utah
- 6064. Centerville, City of, Utah
- 6065. Clearfield, City of, Utah
- 6066. Clinton, City of, Utah
- 6067. Cottonwood Heights, City of, Utah
- 6068. Davis, County of, Utah
- 6069. Draper, City of, Utah
- 6070. Duchesne, County of, Utah
- 6071. Eagle Mountain, City of, Utah
- 6072. Emery, County of, Utah
- 6073. Farmington, City of, Utah
- 6074. Grantsville, City of, Utah
- 6075. Heber, City of, Utah
- 6076. Herriman, City of, Utah
- 6077. Highland, City of, Utah
- 6078. Holladay, City of, Utah
- 6079. Hurricane, City of, Utah
- 6080. Iron, County of, Utah
- 6081. Juab, County of, Utah
- 6082. Kaysville, City of, Utah
- 6083. Kearns metro, Township of, Utah
- 6084. Layton, City of, Utah
- 6085. Lehi, City of, Utah
- 6086. Lindon, City of, Utah
- 6087. Logan, City of, Utah
- 6088. Magna metro, Township of, Utah
- 6089. Mapleton, City of, Utah
- 6090. Midvale, City of, Utah
- 6091. Millard, County of, Utah
- 6092. Millcreek, City of, Utah
- 6093. Morgan, County of, Utah
- 6094. Murray, City of, Utah
- 6095. North Logan, City of, Utah
- 6096. North Ogden, City of, Utah
- 6097. North Salt Lake, City of, Utah
- 6098. Ogden, City of, Utah
- 6099. Orem, City of, Utah
- 6100. Payson, City of, Utah
- 6101. Pleasant Grove, City of, Utah
- 6102. Pleasant View, City of, Utah
- 6103. Provo, City of, Utah
- 6104. Riverton, City of, Utah
- 6105. Roy, City of, Utah
- 6106. Salt Lake City, City of, Utah
- 6107. Salt Lake, County of, Utah
- 6108. San Juan, County of, Utah
- 6109. Sandy, City of, Utah
- 6110. Sanpete, County of, Utah
- 6111. Santaquin, City of, Utah
- 6112. Saratoga Springs, City of, Utah
- 6113. Sevier, County of, Utah
- 6114. Smithfield, City of, Utah
- 6115. South Jordan, City of, Utah
- 6116. South Ogden, City of, Utah
- 6117. South Salt Lake, City of, Utah
- 6118. Spanish Fork, City of, Utah
- 6119. Springville, City of, Utah
- 6120. St. George, City of, Utah
- 6121. Summit, County of, Utah
- 6122. Syracuse, City of, Utah
- 6123. Taylorsville, City of, Utah
- 6124. Tooele, City of, Utah
- 6125. Tooele, County of, Utah
- 6126. Uintah, County of, Utah
- 6127. Utah, County of, Utah
- 6128. Vernal, City of, Utah
- 6129. Vineyard, Town of, Utah

- 6130. Wasatch, County of, Utah
- 6131. Washington, City of, Utah
- 6132. Washington, County of, Utah
- 6133. Weber, County of, Utah
- 6134. West Haven, City of, Utah
- 6135. West Jordan, City of, Utah
- 6136. West Point, City of, Utah
- 6137. West Valley City, City of, Utah
- 6138. Woods Cross, City of, Utah
- 6139. Addison, County of, Vermont
- 6140. Bennington, County of, Vermont
- 6141. Bennington, Town of, Vermont
- 6142. Brattleboro, Town of, Vermont
- 6143. Burlington, City of, Vermont
- 6144. Caledonia, County of, Vermont
- 6145. Chittenden, County of, Vermont
- 6146. Colchester, Town of, Vermont
- 6147. Essex Junction, Village of, Vermont
- 6148. Essex, Town of, Vermont
- 6149. Franklin, County of, Vermont
- 6150. Lamoille, County of, Vermont
- 6151. Milton, Town of, Vermont
- 6152. Orange, County of, Vermont
- 6153. Orleans, County of, Vermont
- 6154. Rutland, City of, Vermont
- 6155. Rutland, County of, Vermont
- 6156. South Burlington, City of, Vermont
- 6157. Washington, County of, Vermont
- 6158. Williston, Town of, Vermont
- 6159. Windham, County of, Vermont
- 6160. Windsor, County of, Vermont
- 6161. Accomack, County of, Virginia
- 6162. Albemarle, County of, Virginia
- 6163. Alexandria, City of, Virginia
- 6164. Alleghany, County of, Virginia
- 6165. Amelia, County of, Virginia
- 6166. Amherst, County of, Virginia
- 6167. Appomattox, County of, Virginia
- 6168. Arlington, County of, Virginia
- 6169. Augusta, County of, Virginia
- 6170. Bedford, County of, Virginia
- 6171. Blacksburg, Town of, Virginia
- 6172. Botetourt, County of, Virginia
- 6173. Bristol, City of, Virginia
- 6174. Brunswick, County of, Virginia
- 6175. Buchanan, County of, Virginia
- 6176. Buckingham, County of, Virginia
- 6177. Campbell, County of, Virginia
- 6178. Caroline, County of, Virginia
- 6179. Carroll, County of, Virginia
- 6180. Charlotte, County of, Virginia
- 6181. Charlottesville, City of, Virginia
- 6182. Chesapeake, City of, Virginia
- 6183. Chesterfield, County of, Virginia
- 6184. Christiansburg, Town of, Virginia
- 6185. Clarke, County of, Virginia
- 6186. Colonial Heights, City of, Virginia
- 6187. Culpeper, County of, Virginia
- 6188. Culpeper, Town of, Virginia
- 6189. Danville, City of, Virginia
- 6190. Dickenson, County of, Virginia
- 6191. Dinwiddie, County of, Virginia
- 6192. Essex, County of, Virginia
- 6193. Fairfax, City of, Virginia
- 6194. Fairfax, County of, Virginia
- 6195. Falls Church, City of, Virginia
- 6196. Fauquier, County of, Virginia
- 6197. Floyd, County of, Virginia
- 6198. Fluvanna, County of, Virginia
- 6199. Franklin, County of, Virginia
- 6200. Frederick, County of, Virginia
- 6201. Fredericksburg, City of, Virginia
- 6202. Front Royal, Town of, Virginia
- 6203. Giles, County of, Virginia
- 6204. Gloucester, County of, Virginia
- 6205. Goochland, County of, Virginia
- 6206. Grayson, County of, Virginia
- 6207. Greene, County of, Virginia
- 6208. Greensville, County of, Virginia
- 6209. Halifax, County of, Virginia
- 6210. Hampton, City of, Virginia
- 6211. Hanover, County of, Virginia
- 6212. Harrisonburg, City of, Virginia
- 6213. Henrico, County of, Virginia
- 6214. Henry, County of, Virginia
- 6215. Herndon, Town of, Virginia
- 6216. Hopewell, City of, Virginia
- 6217. Isle of Wight, County of, Virginia
- 6218. James City, County of, Virginia
- 6219. King George, County of, Virginia
- 6220. King William, County of, Virginia
- 6221. Lancaster, County of, Virginia

- 6222. Lee, County of, Virginia
- 6223. Leesburg, Town of, Virginia
- 6224. Loudoun, County of, Virginia
- 6225. Louisa, County of, Virginia
- 6226. Lunenburg, County of, Virginia
- 6227. Lynchburg, City of, Virginia
- 6228. Madison, County of, Virginia
- 6229. Manassas, City of, Virginia
- 6230. Manassas Park, City of, Virginia
- 6231. Martinsville, City of, Virginia
- 6232. Mecklenburg, County of, Virginia
- 6233. Middlesex, County of, Virginia
- 6234. Montgomery, County of, Virginia
- 6235. Nelson, County of, Virginia
- 6236. New Kent, County of, Virginia
- 6237. Newport News, City of, Virginia
- 6238. Norfolk, City of, Virginia
- 6239. Northampton, County of, Virginia
- 6240. Northumberland, County of, Virginia
- 6241. Nottoway, County of, Virginia
- 6242. Orange, County of, Virginia
- 6243. Page, County of, Virginia
- 6244. Patrick, County of, Virginia
- 6245. Petersburg, City of, Virginia
- 6246. Pittsylvania, County of, Virginia
- 6247. Poquoson, City of, Virginia
- 6248. Portsmouth, City of, Virginia
- 6249. Powhatan, County of, Virginia
- 6250. Prince Edward, County of, Virginia
- 6251. Prince George, County of, Virginia
- 6252. Prince William, County of, Virginia
- 6253. Pulaski, County of, Virginia
- 6254. Purcellville, Town of, Virginia
- 6255. Radford, City of, Virginia
- 6256. Richmond, City of, Virginia
- 6257. Roanoke, City of, Virginia
- 6258. Roanoke, County of, Virginia
- 6259. Rockbridge, County of, Virginia
- 6260. Rockingham, County of, Virginia
- 6261. Russell, County of, Virginia
- 6262. Salem, City of, Virginia
- 6263. Scott, County of, Virginia
- 6264. Shenandoah, County of, Virginia
- 6265. Smyth, County of, Virginia
- 6266. Southampton, County of, Virginia
- 6267. Spotsylvania, County of, Virginia
- 6268. Stafford, County of, Virginia
- 6269. Staunton, City of, Virginia
- 6270. Suffolk, City of, Virginia
- 6271. Sussex, County of, Virginia
- 6272. Tazewell, County of, Virginia
- 6273. Vienna, Town of, Virginia
- 6274. Virginia Beach, City of, Virginia
- 6275. Warren, County of, Virginia
- 6276. Warrenton, Town of, Virginia
- 6277. Washington, County of, Virginia
- 6278. Waynesboro, City of, Virginia
- 6279. Westmoreland, County of, Virginia
- 6280. Williamsburg, City of, Virginia
- 6281. Winchester, City of, Virginia
- 6282. Wise, County of, Virginia
- 6283. Wythe, County of, Virginia
- 6284. York, County of, Virginia
- 6285. Aberdeen, City of, Washington
- 6286. Adams, County of, Washington
- 6287. Anacortes, City of, Washington
- 6288. Arlington, City of, Washington
- 6289. Asotin, County of, Washington
- 6290. Auburn, City of, Washington
- 6291. Bainbridge Island, City of, Washington
- 6292. Battle Ground, City of, Washington
- 6293. Bellevue, City of, Washington
- 6294. Bellingham, City of, Washington
- 6295. Benton, County of, Washington
- 6296. Bonney Lake, City of, Washington
- 6297. Bothell, City of, Washington
- 6298. Bremerton, City of, Washington
- 6299. Burien, City of, Washington
- 6300. Camas, City of, Washington
- 6301. Centralia, City of, Washington
- 6302. Chelan, County of, Washington
- 6303. Cheney, City of, Washington
- 6304. Clallam, County of, Washington
- 6305. Clark, County of, Washington
- 6306. Covington, City of, Washington
- 6307. Cowlitz, County of, Washington
- 6308. Des Moines, City of, Washington
- 6309. Douglas, County of, Washington
- 6310. East Wenatchee, City of, Washington
- 6311. Edgewood, City of, Washington



- 6312. Edmonds, City of, Washington
- 6313. Ellensburg, City of, Washington
- 6314. Enumclaw, City of, Washington
- 6315. Everett, City of, Washington
- 6316. Federal Way, City of, Washington
- 6317. Ferndale, City of, Washington
- 6318. Fife, City of, Washington
- 6319. Franklin, County of, Washington
- 6320. Gig Harbor, City of, Washington
- 6321. Grandview, City of, Washington
- 6322. Grant, County of, Washington
- 6323. Grays Harbor, County of,  
Washington
- 6324. Island, County of, Washington
- 6325. Issaquah, City of, Washington
- 6326. Jefferson, County of, Washington
- 6327. Kelso, City of, Washington
- 6328. Kenmore, City of, Washington
- 6329. Kennewick, City of, Washington
- 6330. Kent, City of, Washington
- 6331. King, County of, Washington
- 6332. Kirkland, City of, Washington
- 6333. Kitsap, County of, Washington
- 6334. Kittitas, County of, Washington
- 6335. Klickitat, County of, Washington
- 6336. Lacey, City of, Washington
- 6337. Lake Forest Park, City of,  
Washington
- 6338. Lake Stevens, City of, Washington
- 6339. Lakewood, City of, Washington
- 6340. Lewis, County of, Washington
- 6341. Liberty Lake, City of, Washington
- 6342. Lincoln, County of, Washington
- 6343. Longview, City of, Washington
- 6344. Lynden, City of, Washington
- 6345. Lynnwood, City of, Washington
- 6346. Maple Valley, City of, Washington
- 6347. Marysville, City of, Washington
- 6348. Mason, County of, Washington
- 6349. Mercer Island, City of, Washington
- 6350. Mill Creek, City of, Washington
- 6351. Monroe, City of, Washington
- 6352. Moses Lake, City of, Washington
- 6353. Mount Vernon, City of, Washington
- 6354. Mountlake Terrace, City of,  
Washington
- 6355. Mukilteo, City of, Washington
- 6356. Newcastle, City of, Washington
- 6357. Oak Harbor, City of, Washington
- 6358. Okanogan, County of, Washington
- 6359. Olympia, City of, Washington
- 6360. Pacific, County of, Washington
- 6361. Pasco, City of, Washington
- 6362. Pend Oreille, County of, Washington
- 6363. Pierce, County of, Washington
- 6364. Port Angeles, City of, Washington
- 6365. Port Orchard, City of, Washington
- 6366. Poulsbo, City of, Washington
- 6367. Pullman, City of, Washington
- 6368. Puyallup, City of, Washington
- 6369. Redmond, City of, Washington
- 6370. Renton, City of, Washington
- 6371. Richland, City of, Washington
- 6372. Sammamish, City of, Washington
- 6373. San Juan, County of, Washington
- 6374. SeaTac, City of, Washington
- 6375. Seattle, City of, Washington
- 6376. Sedro-Woolley, City of, Washington
- 6377. Shelton, City of, Washington
- 6378. Shoreline, City of, Washington
- 6379. Skagit, County of, Washington
- 6380. Skamania, County of, Washington
- 6381. Snohomish, City of, Washington
- 6382. Snohomish, County of, Washington
- 6383. Snoqualmie, City of, Washington
- 6384. Spokane, City of, Washington
- 6385. Spokane, County of, Washington
- 6386. Spokane Valley, City of, Washington
- 6387. Stevens, County of, Washington
- 6388. Sumner, City of, Washington
- 6389. Sunnyside, City of, Washington
- 6390. Tacoma, City of, Washington
- 6391. Thurston, County of, Washington
- 6392. Tukwila, City of, Washington
- 6393. Tumwater, City of, Washington
- 6394. University Place, City of,  
Washington
- 6395. Vancouver, City of, Washington
- 6396. Walla Walla, City of, Washington
- 6397. Walla Walla, County of, Washington
- 6398. Washougal, City of, Washington
- 6399. Wenatchee, City of, Washington

- 6400. West Richland, City of, Washington
- 6401. Whatcom, County of, Washington
- 6402. Whitman, County of, Washington
- 6403. Woodinville, City of, Washington
- 6404. Yakima, City of, Washington
- 6405. Yakima, County of, Washington
- 6406. Adams, County of, Wisconsin
- 6407. Allouez, Village of, Wisconsin
- 6408. Appleton, City of, Wisconsin
- 6409. Ashland, County of, Wisconsin
- 6410. Ashwaubenon, Village of, Wisconsin
- 6411. Baraboo, City of, Wisconsin
- 6412. Barron, County of, Wisconsin
- 6413. Bayfield, County of, Wisconsin
- 6414. Beaver Dam, City of, Wisconsin
- 6415. Bellevue, Village of, Wisconsin
- 6416. Beloit, City of, Wisconsin
- 6417. Brookfield, City of, Wisconsin
- 6418. Brown, County of, Wisconsin
- 6419. Brown Deer, Village of, Wisconsin
- 6420. Buffalo, County of, Wisconsin
- 6421. Burlington, City of, Wisconsin
- 6422. Burnett, County of, Wisconsin
- 6423. Caledonia, Village of, Wisconsin
- 6424. Calumet, County of, Wisconsin
- 6425. Cedarburg, City of, Wisconsin
- 6426. Chippewa, County of, Wisconsin
- 6427. Chippewa Falls, City of, Wisconsin
- 6428. Clark, County of, Wisconsin
- 6429. Columbia, County of, Wisconsin
- 6430. Crawford, County of, Wisconsin
- 6431. Cudahy, City of, Wisconsin
- 6432. Dane, County of, Wisconsin
- 6433. De Pere, City of, Wisconsin
- 6434. DeForest, Village of, Wisconsin
- 6435. Dodge, County of, Wisconsin
- 6436. Door, County of, Wisconsin
- 6437. Douglas, County of, Wisconsin
- 6438. Dunn, County of, Wisconsin
- 6439. Eau Claire, City of, Wisconsin
- 6440. Eau Claire, County of, Wisconsin
- 6441. Elkhorn, City of, Wisconsin
- 6442. Fitchburg, City of, Wisconsin
- 6443. Fond du Lac, City of, Wisconsin
- 6444. Fond du Lac, County of, Wisconsin
- 6445. Fort Atkinson, City of, Wisconsin
- 6446. Fox Crossing, Village of, Wisconsin
- 6447. Franklin, City of, Wisconsin
- 6448. Germantown, Village of, Wisconsin
- 6449. Glendale, City of, Wisconsin
- 6450. Grafton, Village of, Wisconsin
- 6451. Grand Chute, Town of, Wisconsin
- 6452. Grant, County of, Wisconsin
- 6453. Green Bay, City of, Wisconsin
- 6454. Green, County of, Wisconsin
- 6455. Green Lake, County of, Wisconsin
- 6456. Greendale, Village of, Wisconsin
- 6457. Greenfield, City of, Wisconsin
- 6458. Greenville, Town of, Wisconsin
- 6459. Harrison, Village of, Wisconsin
- 6460. Hartford, City of, Wisconsin
- 6461. Hobart, Village of, Wisconsin
- 6462. Holmen, Village of, Wisconsin
- 6463. Howard, Village of, Wisconsin
- 6464. Hudson, City of, Wisconsin
- 6465. Iowa, County of, Wisconsin
- 6466. Jackson, County of, Wisconsin
- 6467. Janesville, City of, Wisconsin
- 6468. Jefferson, County of, Wisconsin
- 6469. Juneau, County of, Wisconsin
- 6470. Kaukauna, City of, Wisconsin
- 6471. Kenosha, City of, Wisconsin
- 6472. Kenosha, County of, Wisconsin
- 6473. Kewaunee, County of, Wisconsin
- 6474. La Crosse, City of, Wisconsin
- 6475. La Crosse, County of, Wisconsin
- 6476. Lafayette, County of, Wisconsin
- 6477. Langlade, County of, Wisconsin
- 6478. Lincoln, County of, Wisconsin
- 6479. Lisbon, Town of, Wisconsin
- 6480. Little Chute, Village of, Wisconsin
- 6481. Madison, City of, Wisconsin
- 6482. Manitowoc, City of, Wisconsin
- 6483. Manitowoc, County of, Wisconsin
- 6484. Marathon, County of, Wisconsin
- 6485. Marinette, City of, Wisconsin
- 6486. Marinette, County of, Wisconsin
- 6487. Marquette, County of, Wisconsin
- 6488. Marshfield, City of, Wisconsin
- 6489. Menasha, City of, Wisconsin
- 6490. Menomonee Falls, Village of, Wisconsin

- 6491. Menomonie, City of, Wisconsin
- 6492. Mequon, City of, Wisconsin
- 6493. Middleton, City of, Wisconsin
- 6494. Milwaukee, City of, Wisconsin
- 6495. Milwaukee, County of, Wisconsin
- 6496. Monroe, City of, Wisconsin
- 6497. Monroe, County of, Wisconsin
- 6498. Mount Pleasant, Village of, Wisconsin
- 6499. Muskego, City of, Wisconsin
- 6500. Neenah, City of, Wisconsin
- 6501. New Berlin, City of, Wisconsin
- 6502. Oak Creek, City of, Wisconsin
- 6503. Oconomowoc, City of, Wisconsin
- 6504. Oconto, County of, Wisconsin
- 6505. Onalaska, City of, Wisconsin
- 6506. Oneida, County of, Wisconsin
- 6507. Oregon, Village of, Wisconsin
- 6508. Oshkosh, City of, Wisconsin
- 6509. Outagamie, County of, Wisconsin
- 6510. Ozaukee, County of, Wisconsin
- 6511. Pewaukee, City of, Wisconsin
- 6512. Pierce, County of, Wisconsin
- 6513. Platteville, City of, Wisconsin
- 6514. Pleasant Prairie, Village of, Wisconsin
- 6515. Plover, Village of, Wisconsin
- 6516. Polk, County of, Wisconsin
- 6517. Port Washington, City of, Wisconsin
- 6518. Portage, City of, Wisconsin
- 6519. Portage, County of, Wisconsin
- 6520. Price, County of, Wisconsin
- 6521. Racine, City of, Wisconsin
- 6522. Racine, County of, Wisconsin
- 6523. Richfield, Village of, Wisconsin
- 6524. Richland, County of, Wisconsin
- 6525. River Falls, City of, Wisconsin
- 6526. Rock, County of, Wisconsin
- 6527. Rusk, County of, Wisconsin
- 6528. Salem Lakes, Village of, Wisconsin
- 6529. Sauk, County of, Wisconsin
- 6530. Sawyer, County of, Wisconsin
- 6531. Shawano, County of, Wisconsin
- 6532. Sheboygan, City of, Wisconsin
- 6533. Sheboygan, County of, Wisconsin
- 6534. Shorewood, Village of, Wisconsin
- 6535. South Milwaukee, City of, Wisconsin
- 6536. St. Croix, County of, Wisconsin
- 6537. Stevens Point, City of, Wisconsin
- 6538. Stoughton, City of, Wisconsin
- 6539. Suamico, Village of, Wisconsin
- 6540. Sun Prairie, City of, Wisconsin
- 6541. Superior, City of, Wisconsin
- 6542. Sussex, Village of, Wisconsin
- 6543. Taylor, County of, Wisconsin
- 6544. Trempealeau, County of, Wisconsin
- 6545. Two Rivers, City of, Wisconsin
- 6546. Vernon, County of, Wisconsin
- 6547. Verona, City of, Wisconsin
- 6548. Vilas, County of, Wisconsin
- 6549. Walworth, County of, Wisconsin
- 6550. Washburn, County of, Wisconsin
- 6551. Washington, County of, Wisconsin
- 6552. Watertown, City of, Wisconsin
- 6553. Waukesha, City of, Wisconsin
- 6554. Waukesha, County of, Wisconsin
- 6555. Waunakee, Village of, Wisconsin
- 6556. Waupaca, County of, Wisconsin
- 6557. Waupun, City of, Wisconsin
- 6558. Wausau, City of, Wisconsin
- 6559. Waushara, County of, Wisconsin
- 6560. Wauwatosa, City of, Wisconsin
- 6561. West Allis, City of, Wisconsin
- 6562. West Bend, City of, Wisconsin
- 6563. Weston, Village of, Wisconsin
- 6564. Whitefish Bay, Village of, Wisconsin
- 6565. Whitewater, City of, Wisconsin
- 6566. Winnebago, County of, Wisconsin
- 6567. Wisconsin Rapids, City of, Wisconsin
- 6568. Wood, County of, Wisconsin
- 6569. Albany, County of, Wyoming
- 6570. Big Horn, County of, Wyoming
- 6571. Campbell, County of, Wyoming
- 6572. Carbon, County of, Wyoming
- 6573. Casper, City of, Wyoming
- 6574. Cheyenne, City of, Wyoming
- 6575. Converse, County of, Wyoming
- 6576. Evanston, City of, Wyoming
- 6577. Fremont, County of, Wyoming

- 6578. Gillette, City of, Wyoming
- 6579. Goshen, County of, Wyoming
- 6580. Green River, City of, Wyoming
- 6581. Jackson, Town of, Wyoming
- 6582. Laramie, City of, Wyoming
- 6583. Laramie, County of, Wyoming
- 6584. Lincoln, County of, Wyoming
- 6585. Natrona, County of, Wyoming
- 6586. Park, County of, Wyoming
- 6587. Riverton, City of, Wyoming
- 6588. Rock Springs, City of, Wyoming
- 6589. Sheridan, City of, Wyoming
- 6590. Sheridan, County of, Wyoming
- 6591. Sweetwater, County of, Wyoming
- 6592. Teton, County of, Wyoming
- 6593. Uinta, County of, Wyoming

## **EXHIBIT J**

### **Illustrative List of Released Entities**

Wal-Mart  
Wal-Mart Inc.  
Wal-Mart, Inc.  
Wal-Mart Stores  
Wal-Mart Stores, Inc.  
Walmart Stores, Inc.  
Wal-Mart Stores Inc.  
Walmart Inc.  
Walmart Inc., Walmart Stores East  
Wal-Mart Inc f/k/a Walmart Stores, Inc.  
Wal-Mart Inc. f/k/a Walmart Stores, Inc.  
Walmart Inc. (f/k/a Wal-Mart Stores)  
Walmart Inc. f/k/a Wal-Mart Stores, Inc.  
Walmart, Inc.  
Walmart, Inc. f/k/a Wal-Mart Stores Inc. d/b/a Wal-Mart Warehouse #46  
Walmart Inc. f/k/a Wal-Mart Stores, Inc. d/b/a Wal-Mart Pharmacy Warehouse #32  
Walmart Inc. f/k/a Wal-Mart Stores, Inc. d/b/a Wal-Mart Pharmacy Warehouse #45  
Walmart, Inc. f/k/a Wal-Mart Stores, Inc.  
WAL-MART INC. f/k/a WAL-MART STORES, INC.  
Walmart, Inc. f/k/a Wal-Mart Stores, Inc. d/b/a Wal-Mart Pharmacies a/k/a Wal-Mart Pharmacy  
10-1218  
Walmart, Inc. f/k/a Wal-Mart Stores, Inc. d/b/a Wal-Mart Pharmacies a/k/a Wal-Mart Pharmacy  
10-1381  
Walmart, Inc. f/k/a Wal-Mart Stores, Inc. d/b/a Wal-Mart Pharmacies a/k/a Wal-Mart Pharmacy  
10-2778  
Walmart, Inc. f/k/a Wal-Mart Stores, Inc. d/b/a Wal-Mart Pharmacies a/k/a Wal-Mart Pharmacy  
10-3751  
Walmart, Inc. f/k/a Wal-Mart Stores, Inc. d/b/a Wal-Mart Pharmacies a/k/a Wal-Mart Pharmacy  
10-4430  
Walmart Inc., f/k/a Wal-Mart Stores East, LP, Individually and d/b/a Wal-Mart Pharmacy  
Warehouses  
Walmart Stores East, L.P.  
Wal-Mart Stores East  
Wal-Mart Stores East L.P.  
Wal-Mart Stores East d/b/a Wal-Mart Pharmacy Warehouse #45  
Wal-Mart Stores East d/b/a Wal-Mart Pharmacy Warehouse #46  
Wal-Mart Stores East, Inc.  
Wal-Mart Stores East, LLC  
Wal-Mart Stores East, LLC f/k/a Wal-Mart Stores East Inc.  
Wal-Mart Stores East, LP  
Wal-Mart Stores East, LP d/b/a Wal-Mart Pharmacy Warehouse  
Wal-Mart Stores East, LP, individually and d/b/a Wal-Mart Pharmacy Warehouse  
Wal-Mart Stores East, LP, individually and d/b/a Wal-Mart Pharmacy Warehouse #1

Wal-Mart Stores East, LP, individually and d/b/a Wal-Mart Pharmacy Warehouse #45  
Wal-Mart Stores East, LP, individually and d/b/a Wal-Mart Pharmacy Warehouse #46  
Wal-Mart Stores East, LP d/b/a Wal-Mart Pharmacy Warehouse #1  
Wal-Mart Stores East, LP d/b/a Wal-Mart Pharmacy Warehouse #32  
Wal-Mart Stores East, LP d/b/a Wal-Mart Pharmacy Warehouse #34  
Wal-Mart Stores East, LP d/b/a Wal-Mart Pharmacy Warehouse #45  
Wal-Mart Stores East, LP d/b/a Walmart Pharmacy Warehouse #46  
Wal-Mart Stores East, LP d/b/a Wal-Mart Pharmacy 10-3251  
Wal-Mart Stores East I, LP  
Wal-Mart Stores East I, LP f/k/a Wal-Mart Stores East d/b/a Walmart #20  
Wal-Mart Stores East I, LP f/k/a Wal-Mart Stores East, LP d/b/a Walmart #34  
Wal-Mart Stores East I, LP f/k/a Wal-Mart Stores East, LP d/b/a Walmart #48  
Wal-Mart Stores East I, LP f/k/a Wal-Mart Stores East d/b/a Walmart #92  
Wal-Mart Stores East I, LP f/k/a Wal-Mart Stores East, LP d/b/a Walmart #338  
Wal-Mart Stores East I, LP f/k/a Wal-Mart Stores East, LP d/b/a Walmart #914  
Wal-Mart Stores East I, LP f/k/a Wal-Mart Stores East, LP d/b/a Walmart #4282  
Wal-Mart Stores East I, LP f/k/a Wal-Mart Stores East, LP d/b/a Walmart #5261  
Wal-Mart Pharmacy  
Wal-Mart Pharmacy Warehouse  
Wal-Mart Pharmacy Warehouse #1  
Wal-Mart Pharmacy Warehouse #32  
Wal-Mart Pharmacy Warehouse #45  
Wal-Mart Pharmacy Warehouse #46  
Wal-Mart Pharmacy 10-0696  
Wal-Mart Pharmacy 10-1218  
Walmart Pharmacy  
Walmart Pharmacy 10-1381  
Walmart Pharmacy 10-2289  
Walmart Pharmacy Warehouse  
Wal-Mart Pharmacy 10-2778  
Wal-Mart Pharmacy 10-3251  
Wal-Mart Pharmacy 10-3751  
Wal-Mart Pharmacy 10-4430  
Wal-Mart Pharmacy 10-5296  
Wal-Mart Pharmacy 10-5397  
Wal-Mart Pharmacy Wholesale  
Wal-Mart Stores Texas, LLC  
Wal-Mart.com USA, LLC  
Wal-Mart Puerto Rico, Inc.  
Sam's West, Inc.  
Sam's East, Inc.  
WSE Investment LLC  
WSE Management LLC  
Wal-Mart Property Company  
Wal-Mart Real Estate Business Trust  
Sam's Property Company

Sam's Real Estate Business Trust  
Wal-Mart de Mexico Canada Corp.  
Wal-Mart Canada Corp  
Flipkart Private Limited  
Flipkart Walmart Chile S.A.  
Walmart Chile  
Massmart Holdings Ltd.  
Qomolangma Holdings Ltd.  
ClarusONE Sourcing Services, LLP

**EXHIBIT K**

**Subdivision Participation Form**

Governmental Entity:	State:
Authorized Official:	
Address 1:	
Address 2:	
City, State, Zip:	
Phone:	
Email:	

The governmental entity identified above (“Governmental Entity”), in order to obtain and in consideration for the benefits provided to the Governmental Entity pursuant to the Settlement Agreement dated November 14, 2022 (“Walmart Settlement”), and acting through the undersigned authorized official, hereby elects to participate in the Walmart Settlement, release all Released Claims against all Released Entities, and agrees as follows.

1. The Governmental Entity is aware of and has reviewed the Walmart Settlement, understands that all terms in this Election and Release have the meanings defined therein, and agrees that by this Election, the Governmental Entity elects to participate in the Walmart Settlement and become a Participating Subdivision as provided therein.
2. The Governmental Entity shall promptly, and in any event within 14 days of the Effective Date and prior to the filing of the Consent Judgment, dismiss with prejudice any Released Claims that it has filed.
3. The Governmental Entity agrees to the terms of the Walmart Settlement pertaining to Subdivisions as defined therein.
4. By agreeing to the terms of the Walmart Settlement and becoming a Releasor, the Governmental Entity is entitled to the benefits provided therein, including, if applicable, monetary payments beginning after the Effective Date.
5. The Governmental Entity agrees to use any monies it receives through the Walmart Settlement solely for the purposes provided therein.
6. The Governmental Entity submits to the jurisdiction of the court in the Governmental Entity’s state where the Consent Judgment is filed for purposes limited to that court’s role as provided in, and for resolving disputes to the extent provided in, the Walmart Settlement.
7. The Governmental Entity has the right to enforce the Walmart Settlement as provided therein.
8. The Governmental Entity, as a Participating Subdivision, hereby becomes a Releasor for all purposes in the Walmart Settlement, including but not limited to all provisions of Section X (Release), and along with all departments, agencies, divisions, boards,



commissions, districts, instrumentalities of any kind and attorneys, and any person in their official capacity elected or appointed to serve any of the foregoing and any agency, person, or other entity claiming by or through any of the foregoing, and any other entity identified in the definition of Releasor, provides for a release to the fullest extent of its authority. As a Releasor, the Governmental Entity hereby absolutely, unconditionally, and irrevocably covenants not to bring, file, or claim, or to cause, assist or permit to be brought, filed, or claimed, or to otherwise seek to establish liability for any Released Claims against any Released Entity in any forum whatsoever. The releases provided for in the Walmart Settlement are intended by the Parties to be broad and shall be interpreted so as to give the Released Entities the broadest possible bar against any liability relating in any way to Released Claims and extend to the full extent of the power of the Governmental Entity to release claims. The Walmart Settlement shall be a complete bar to any Released Claim.

9. In connection with the releases provided for in the Walmart Settlement, each Governmental Entity expressly waives, releases, and forever discharges any and all provisions, rights, and benefits conferred by any law of any state or territory of the United States or other jurisdiction, or principle of common law, which is similar, comparable, or equivalent to § 1542 of the California Civil Code, which reads:

**General Release; extent.** A general release does not extend to claims that the creditor or releasing party does not know or suspect to exist in his or her favor at the time of executing the release that, if known by him or her, would have materially affected his or her settlement with the debtor or released party.

A Releasor may hereafter discover facts other than or different from those which it knows, believes, or assumes to be true with respect to the Released Claims, but each Governmental Entity hereby expressly waives and fully, finally, and forever settles, releases and discharges, upon the Effective Date, any and all Released Claims that may exist as of such date but which Releasors do not know or suspect to exist, whether through ignorance, oversight, error, negligence or through no fault whatsoever, and which, if known, would materially affect the Governmental Entities' decision to participate in the Walmart Settlement.

10. Nothing herein is intended to modify in any way the terms of the Walmart Settlement, to which Governmental Entity hereby agrees. To the extent this Election and Release is interpreted differently from the Walmart Settlement in any respect, the Walmart Settlement controls.

I have all necessary power and authorization to execute this Election and Release on behalf of the Governmental Entity.

Signature: \_\_\_\_\_

Name: \_\_\_\_\_

Title: \_\_\_\_\_

Date: \_\_\_\_\_

**EXHIBIT L**

**Settlement Fund Administrator Terms**

[Exhibit to be inserted prior to the Threshold Subdivision Participation Date.]

**EXHIBIT M**

**Maximum Payment Amounts**

The below reflects the maximum possible payment assuming all Eligible States and Subdivisions become Settling States and Participating Subdivisions, respectively.

<b>Payment Category</b>	<b>Amount</b>
Remediation	\$2,393,794,118.64
Subdivision Attorneys' Fees, Expenses and Costs	\$297,720,376.93
State Outside Counsel Fee Fund	\$16,006,471.88
State Cost Fund	\$16,006,471.88
Additional Remediation	\$16,006,471.88
<b>Total</b>	<b>\$2,739,533,911.21</b>

**EXHIBIT N**

**Additional Remediation Amount Allocation Percentages**

<b>American Samoa</b>	0.02200115975%
<b>Arizona</b>	3.05252465675%
<b>California</b>	12.74849736613%
<b>Colorado</b>	2.13511305177%
<b>Connecticut</b>	1.66248361102%
<b>District of Columbia</b>	0.23126235968%
<b>Georgia</b>	3.58271243432%
<b>Guam</b>	0.06172478010%
<b>Hawaii</b>	0.41715801047%
<b>Idaho</b>	0.63207800237%
<b>Illinois</b>	4.27418134712%
<b>Indiana</b>	2.84860067110%
<b>Iowa</b>	0.95333852745%
<b>Kansas</b>	1.00750402880%
<b>Louisiana</b>	1.88257043645%
<b>Maine</b>	0.68015462142%
<b>Maryland</b>	2.71203054235%
<b>Massachusetts</b>	2.95998387959%
<b>Minnesota</b>	1.66691605927%
<b>Missouri</b>	2.57716004997%
<b>Montana</b>	0.40160929605%
<b>N. Mariana Islands</b>	0.02146629937%
<b>Nebraska</b>	0.53602352921%
<b>New Jersey</b>	3.54021579836%
<b>New York</b>	6.92637929997%
<b>North Carolina</b>	4.17641738164%
<b>North Dakota</b>	0.21847415675%
<b>Ohio</b>	5.59815538035%
<b>Oklahoma</b>	1.96884304616%
<b>Oregon</b>	1.76570407913%
<b>Pennsylvania</b>	5.89566898881%
<b>Rhode Island</b>	0.57378605088%
<b>South Carolina</b>	1.97793678247%
<b>Tennessee</b>	3.45413951394%
<b>Texas</b>	8.08647780880%
<b>Vermont</b>	0.32700612791%

<b>Virgin Islands</b>	0.04056252728%
<b>Virginia</b>	2.92983758737%
<b>Washington</b>	2.97967950241%
<b>Wisconsin</b>	2.25927398859%
<b>Wyoming</b>	0.21434725869%

## EXHIBIT O

### Adoption of a State-Subdivision Agreement

A State-Subdivision Agreement shall be applied if it meets the requirements of Section V of the Settlement Agreement and is approved by the State and by the State's Subdivisions as follows:

1. *Requirements for Approval.* A State-Subdivision Agreement shall be deemed as agreed to when it has been approved by the State and either (a) Subdivisions whose aggregate "Population Percentages," determined as set forth below, total more than sixty percent (60%), or (b) Subdivisions whose aggregate Population Percentages total more than fifty percent (50%) provided that these Participating Subdivisions also represent fifteen percent (15%) or more of the State's counties or parishes (or, in the case of Settling States whose counties and parishes do not function as local governments, 15% of or more of the Settling State's non-county Subdivisions), by number.
2. *Approval Authority.* Approval by the State shall be by the Attorney General. Approval by a Subdivision shall be by the appropriate official or legislative body pursuant to the required procedures for that Subdivision to agree to a legally binding settlement.
3. *Population Percentage Calculation.* For purposes of this Exhibit O only, Population Percentages shall be determined as follows: For States with functional counties or parishes<sup>1</sup>, the Population Percentage of each county or parish shall be deemed to be equal to (a) (1) 200% of the population of such county or parish, minus (2) the aggregate population of all Primary Incorporated Municipalities located in such county or parish, divided by (b) 200% of the State's population. A "Primary Incorporated Municipality" means a city, town, village or other municipality incorporated under applicable state law with a population of at least 25,000 that is not located within another incorporated municipality. The Population Percentage of each Primary Incorporated Municipality shall be equal to its population (including the population of any incorporated or unincorporated municipality located therein) divided by 200% of the State's population; *provided* that the Population Percentage of a Primary Incorporated Municipality that is not located within a county shall be equal to 200% of its population (including the population of any incorporated or unincorporated municipality located therein) divided by 200% of the State's population. For all States that do not have functional counties or parishes, the Population Percentage of each non-county Subdivision (including any incorporated or unincorporated municipality located therein), shall be equal to its population divided by the State's population.
4. *Preexisting Agreements and Statutory Provisions.* A State may include with the notice to its Subdivisions an existing agreement, a proposed agreement, or statutory provisions regarding the distribution and use of settlement funds and have the acceptance of such an agreement or statutory provision be part of the requirements to be a Participating Subdivision.

---

<sup>1</sup> Certain states do not have counties or parishes that have functional governments, including: Alaska, Connecticut, Massachusetts, Rhode Island, and Vermont.

5. *Revised Agreements.* A State-Subdivision Agreement that has been revised, supplemented, or refined shall be applied if it meets the requirements of Section V and is approved by the State and by the State's Subdivisions pursuant to the terms above.



## **EXHIBIT P**

### **Injunctive Relief**

As part of this Settlement Agreement, Walmart agrees to implement the injunctive relief terms reflected in Exhibit F to Walmart’s agreement with the State of Florida dated October 19, 2022, attached hereto as Appendix A (“Walmart-Florida Injunctive Relief Terms”), within 90 days of the Effective Date of the Settlement Agreement, provided, however, that the parties agree that those terms will be withdrawn and Walmart will implement the Pharmacy Controlled Substance Compliance Program & Anti-Diversion Injunctive Terms (“Injunctive Terms”) set out below if each Chain Pharmacy (defined as CVS and Walgreens) agrees to implement materially the same Injunctive Terms on a nationwide basis pursuant to a binding agreement with state attorneys general. To the extent there is a dispute between the Settling States and Walmart regarding whether the Injunctive Terms imposed on other pharmacies are materially the same as these Injunctive Terms, such dispute shall be heard by the National Arbitration Panel. If any Injunctive Term is found to be materially different, only that term and any co-dependent terms, as applicable, would be invalidated and inoperative. However, in no event shall the Injunctive Terms be any less stringent than those applied in the Walmart-Florida Injunctive Relief Terms. In the event a Settling State later settles with Albertsons or Kroger (or a merged company involving one or more of them), the Settling State shall impose materially the same Injunctive Terms as part of any settlement.

\* \* \*

## **Pharmacy Controlled Substance Compliance Program & Anti-Diversion Injunctive Terms**

### **I. INTRODUCTION**

1. Except where these Injunctive Terms specify a different implementation period, Walmart shall implement the Injunctive Terms set forth below in Sections II through XVII by the Injunctive Terms Implementation Date (defined below).
2. To the extent that Walmart already has in place committees, departments, policies or programs that satisfy the Injunctive Terms, no re-naming or other change is required by these Injunctive Terms.
3. Overview
  - a. Walmart will implement or maintain a Controlled Substance Compliance Program (“CSCP”).
  - b. The CSCP must include written standard operating procedures and/or corporate policies (the “CSCP Policies and Procedures”) required by these Injunctive Terms.

- c. The CSCP shall apply during the term of these Injunctive Terms, to each of Walmart's retail pharmacy stores that dispense Schedule II Designated Controlled Substances and are registered or licensed with each Settling State.
- d. Walmart shall provide a copy of the relevant CSCP Policies and Procedures to each Settling State within 60 days of the Injunctive Terms Implementation Date. To the extent any implementation is expected to require additional time, the Parties agree to work together in good faith to establish a timeline for implementation. No later than 30 days after the Injunctive Terms Implementation Date, each Settling State shall identify the person or office to whom Walmart must provide a copy of the relevant CSCP Policies and Procedures and any other State-specific reporting required under these Injunctive Terms.

#### 4. Compliance with Laws

- a. Walmart acknowledges and agrees that its pharmacies must comply with applicable state and federal laws, regulations, and rules, including those regarding the dispensing of Controlled Substances. The requirements of these Injunctive Terms are in addition to, and not in lieu of, any other requirements of federal, state, or local law. Nothing in the Injunctive Terms shall be construed as relieving Walmart of the obligation of its pharmacies to comply with all federal, state and local laws, regulations or rules, nor shall any of the provisions of the Injunctive Terms be deemed as permission for Walmart to engage in any acts or practices prohibited by such laws, regulations or rules.
- b. The Injunctive Terms are not intended to and shall not be interpreted to prevent Walmart from taking or implementing any other compliance or policy steps necessary to conform with federal, state, or local legal requirements.
- c. In the event that Walmart 1) determines that there may be a conflict between the Injunctive Terms and the requirements of federal, state, or local laws, or interpretations of such laws articulated by an agency responsible for enforcing such laws, such that Walmart determines that it cannot comply with the Injunctive Terms without violating these requirements or express interpretations; or 2) believes a court or administrative action brought by a governmental body in a Settling State has commenced against it or its pharmacists for actions required by the Injunctive Terms, then Walmart may notify the Attorney General of the Settling State of such potential conflict or potential or pending action. Within thirty (30) days after receipt of a notification from Walmart referenced above, Walmart and the State shall meet and discuss the potential conflict, and Walmart shall comply with any reasonable requests from the Settling State as necessary to determine whether there is a conflict between the Injunctive Terms and the requirements of federal, state, or local

laws, or the express interpretations thereof by an agency responsible for their enforcement, or a conflict with the Injunctive Terms giving rise to the court or administrative action. If the State agrees that there is a conflict or that the court or administrative action is a result of actions required by the Injunctive Terms, the State will engage in best efforts to resolve the conflict or assist in achieving resolution of the court or administrative action. Nothing in this paragraph shall (i) limit the right of the State to disagree with Walmart as to the conflict; or (ii) be deemed to relieve Walmart from following any subsequently enacted law or regulation, or judicial decisions from a regulatory authority with jurisdiction over controlled substances that is more restrictive than the provisions of the Injunctive Terms, or from following the Injunctive Terms if they are more restrictive than applicable laws at issue in the administrative action; or (iii) be deemed to relieve Walmart from adhering to the outcome of the court or administrative action when it is determined there is no conflict..

- d. Walmart shall retain all records it is required to create pursuant to its obligations hereunder in an electronic or otherwise easily accessible format and a Settling State shall have the right to review and copy such records upon request and after reasonable notice for the term of these Injunctive Terms. Nothing in these Injunctive Terms shall waive any applicable privilege that may be asserted over any such record. Unless otherwise required by law, if a Settling State seeks to disclose any records created and obtained from Walmart under this provision as part of a proceeding to enforce these Injunctive Terms against Walmart, it shall first provide ten (10) days' notice to Walmart unless doing so would conflict with applicable law. A Settling State shall not otherwise disclose or provide any records created by and obtained from Walmart under this provision to third parties during or after the Term of these Injunctive Terms unless required to do so by law. If a Settling State is required to disclose or provide any records created by and obtained from Walmart under this provision to third parties during or after the Term of these Injunctive Terms, it shall first provide ten (10) days' notice to Walmart unless doing so would conflict with applicable law. This notification requirement shall not apply to documents obtained by a Settling State or its agencies that are required to be produced to the Settling State or its agencies by law or regulation, nor shall it apply to documents obtained by a Settling State or its agencies that are shared with federal, state, or local law enforcement. This notification requirement shall also not apply to documents obtained by a Settling State or its agencies from other sources.

5. No Admission and No Use as Evidence. Walmart does not admit liability or wrongdoing. These Injunctive Terms shall not be considered, construed, or represented to be (1) an admission, concession, or evidence of liability or wrongdoing or (2) a waiver or limitation of any defense otherwise available to Walmart. These Injunctive Terms shall not be offered or received in evidence in any action or proceeding for any purpose other than in an action or proceeding arising under or relating to these Injunctive Terms.

## **II. TERM AND SCOPE**

1. The term of these Injunctive Terms shall be from the Injunctive Terms Implementation Date until ten years from the Injunctive Terms Implementation Date, unless otherwise specified herein.
2. Except as otherwise stated herein, the Injunctive Terms shall apply to Walmart's retail pharmacy stores registered or licensed with each Settling State that dispense Schedule II Designated Controlled Substances to Patients and to Schedule II Designated Controlled Substances dispensed to patients in each Settling State by its mail-order pharmacy. Should Walmart operate an online pharmacy that is registered or licensed to dispense Schedule II Designated Controlled Substances in any Settling State while these Injunctive Terms are in effect, the Injunctive Terms shall apply to such online pharmacy as well.
3. This agreement may be amended by mutual agreement of a majority of the States Injunctive Relief Committee and Walmart. Any such amendments must be in writing.

## **III. DEFINITIONS**

1. The term "Distributor Injunctive Terms" means Exhibit P of the Settlement Agreement, dated as of July 21, 2021, between McKesson Corporation, Cardinal Health, Inc., and AmerisourceBergen Corporation and certain States and subdivisions.
2. The term "Block" means an action taken by Walmart preventing or otherwise prohibiting any Walmart pharmacist from filling prescriptions for Controlled Substances from a specific identified prescriber.
3. The term "Clearinghouse" means the system established by Section XVII of the Distributor Injunctive Terms.
4. The term "Clearinghouse Advisory Panel" is as defined in Section XVII.B.4 of the Distributor Injunctive Terms.

5. The term “Controlled Substances” means those substances designated under schedules II-V pursuant to the federal Controlled Substances Act and the laws and regulations of the Settling State that incorporate the federal Controlled Substances Act. Controlled Substances shall also include gabapentin, except for purposes of dispensing in States that do not treat gabapentin as a controlled substance or similar designation (e.g., “drug of concern”).
6. The term “Designated Controlled Substances” shall be limited to: (a) oxycodone; (b) hydrocodone; (c) hydromorphone; (d) tramadol; (e) oxymorphone; (f) morphine; (g) methadone; and (h) fentanyl.
7. The term “Effective Date” is defined in Section II.C of the Walmart Settlement Agreement.
8. The term “Injunctive Terms Implementation Date” means (i) 90 days after the Effective Date of the Settlement Agreement, or (ii) 90 days after CVS and Walgreens have agreed to implement materially the same Injunctive Terms nationwide pursuant to a binding agreement with state attorneys general and such Injunctive Terms imposed upon CVS and Walgreens have become effective, whichever is later. To the extent there is a dispute between the Settling States and Walmart regarding whether the Injunctive Terms imposed on other pharmacies are materially the same as these Injunctive Terms, such dispute shall be heard by the National Arbitration Panel. If any Injunctive Term is found to be materially different, only that term and any co-dependent terms, as applicable, would be invalidated and inoperative. However, in no event shall the Injunctive Terms be any less stringent than those applied in the Walmart-Florida Injunctive Relief Terms.
9. The term “National Arbitration Panel” is defined in Section VI.F.3.b of the Walmart Settlement Agreement.
10. The term “Patient” means any individual who receives a prescription for a Designated Controlled Substance from a Prescriber, whether legally valid or not, and attempts to fill it at one of Walmart’s retail pharmacy stores in a Settling State.
11. The term “Prescriber” means any individual that has written a prescription, whether legally valid or not, that is presented to a Walmart pharmacy in a Settling State.
12. The term “Red Flag(s)” means the enumerated Patient Red Flags, Prescription Red Flags, and Prescriber Red Flags set out in Section IX.
13. The term “Settling State(s)” is defined in Section I.MMM of the Walmart Settlement Agreement.
14. The term “States Injunctive Relief Committee” means a committee representing the Settling States composed of between four and eight members designated by the Settling States.

#### **IV. CONTROLLED SUBSTANCE COMPLIANCE PERSONNEL**

1. Walmart shall designate a Controlled Substance Compliance Director, or other appropriately titled position, to be a member of the Controlled Substance Compliance Committee (described below in Section VI), and to oversee a Controlled Substance Compliance Department and Walmart's compliance with 21 C.F.R. 1306 these Injunctive Terms. As used in these Injunctive Terms, the terms "Controlled Substance Compliance Committee" and "Controlled Substance Compliance Department" refer to the entity or entities, however titled, that carry out the functions required by these Injunctive Terms. Notwithstanding the preceding sentence, to the extent an existing position, committee or department carries out the functions required by these Injunctive Terms, any other functions undertaken by such position, committee or department shall not be subject to these Injunctive Terms or oversight by the Settling States pursuant to these Injunctive Terms. The position, committee and department discussed in these Terms may bear different names and need not be limited to the roles and functions set forth herein.
2. The Controlled Substance Compliance Director shall have knowledge of and experience with the laws and regulation of Controlled Substances, in particular laws and regulations regarding 21 C.F.R. 1306 and requiring effective controls against the potential diversion of Controlled Substances.
3. The Controlled Substance Compliance Director shall provide at least quarterly reports to the Controlled Substance Compliance Committee (described below in Section VI) regarding Walmart's compliance with these Injunctive Terms, including the implementation of any changes to the CSCP Policies and Procedures required by these Injunctive Terms.
4. Staffing levels of Walmart's Controlled Substance Compliance Department shall be reviewed periodically, but at least on an annual basis, by Walmart's Controlled Substance Compliance Committee to assess whether such staffing levels are sufficient for the Controlled Substance Compliance Department to comply with this Agreement. This review shall include consideration of relevant developments in technology, law, and regulations.
5. Throughout the term of these Injunctive Terms, Walmart shall maintain a telephone and electronic submission hotline(s) (the "Hotline") to permit employees and/or Patients to anonymously report suspected inappropriate or illegitimate dispensing, prescribing or diversion of Designated Controlled Substances, violations of the CSCP Policies and Procedures, these Injunctive Terms, Walmart's company policy, or other applicable law. The Hotline may be implemented by adding a dedicated option to existing systems that includes reporting regarding Designated Controlled Substances. Walmart shall publish its Hotline contact information to its employees and Patients in the Settling States. Walmart shall maintain for the duration of Injunctive Terms a record of each complaint made to the Hotline regarding Designated Controlled Substances and

documentation regarding any investigation or response to such complaints. Nothing herein shall require Walmart to investigate a pharmacist's professional judgment to refuse a prescription that the pharmacist believes was prescribed or is being used for other than a legitimate medical purpose or that the pharmacist believes was not prescribed by an individual Prescriber acting in the usual course of his or her professional practice.

**V. INDEPENDENCE**

1. Walmart's Controlled Substance Compliance Department personnel, pharmacists and pharmacist technicians who work at Walmart's pharmacies within the Settling States, and field personnel who supervise pharmacists and pharmacist technicians (together, "CSCP Employees"), shall not be compensated in whole or in part by commissions, bonuses, incentives or any other monetary or non-pecuniary benefit that depends in any part on revenue or profitability targets or expectations for sales of Controlled Substances. Nothing in these Injunctive Terms shall be interpreted to prevent compensation of employees based on sales volume, revenue or profitability targets/expectations for enterprise-, store-, or pharmacy-wide sales that include Controlled Substances.
2. No CSCP Employees may be terminated, suspended, threatened with or face any other negative employment consequence for failing to meet any revenue or profitability targets or expectations for sales of Controlled Substances. Nothing in these Injunctive Terms shall be interpreted to prevent Walmart from taking employment action based on sales volume, revenue or profitability targets/expectations for enterprise-, store-, or pharmacy-wide sales that include Controlled Substances.
3. Personnel in Walmart's Controlled Substance Compliance Department shall not report to Walmart's sales, marketing, or business development personnel, and sales, marketing, or business development personnel shall not be authorized to make decisions regarding the promotion, compensation, demotion, admonition, discipline, commendation, periodic performance reviews, hiring, or firing of Controlled Substance Compliance Department personnel.
4. Walmart's sales, marketing and business development department personnel are prohibited from interfering with, obstructing, or otherwise exerting control over any Controlled Substance Compliance Department or Controlled Substance Committee decision-making.
5. Notwithstanding the prior paragraph, Walmart pharmacy operations personnel may sit on the Controlled Substance Compliance Committee and pharmacists and pharmacy managers may sit on the Controlled Substance Compliance Committee provided that they do not have voting privileges.

6. To the extent necessary to comply with this section, Walmart's Controlled Substance Compliance Committee shall review, modify, and direct any changes to any compensation and non-retaliation policies specific to the sale or dispensing of Designated Controlled Substances.

## **VI. OVERSIGHT**

1. To the extent not already established, within thirty (30) business days of the Injunctive Terms Implementation Date, Walmart shall establish a compliance committee, however titled, that includes representatives from its respective legal, compliance, pharmacy operations and finance departments, however named, to provide oversight over the CSCP and its compliance with the Injunctive Terms. For the purposes of reference herein, this committee, however named, shall be referred to as the "Controlled Substance Compliance Committee." Walmart shall maintain its Controlled Substance Compliance Committee for the duration of the term of the Injunctive Terms. The Controlled Substance Compliance Director shall be a member of the Controlled Substance Compliance Committee.
2. Walmart's Controlled Substance Compliance Committee shall have quarterly meetings during which the Controlled Substance Compliance Director shall report on, and the Controlled Substance Compliance Committee shall review, among other things, (a) the Prescription Validation Process, including the CSCP Policies and Procedures on identifying and resolving Patient, Prescriber and Prescription Red Flags; (b) the training required under the Injunctive Terms; (c) proactive due diligence and site visits; (d) the Prescriber Review Processes; (e) significant new national and regional diversion trends involving Controlled Substances; (f) Walmart's adherence to the Injunctive Terms and applicable laws and regulations; and (g) any technology, staffing, or other resource needs for the CSCP. The Controlled Substance Compliance Committee shall have access to all CSCP reports described in the following subsection.
3. On an annual basis, Walmart's Controlled Substance Compliance Committee shall provide a written report to Walmart's President, Chief Financial Officer, Chief Legal Officer, and Chief Compliance Officer, as well as its Board of Directors, outlining (a) Walmart's adherence to, and any material deviations from these Injunctive Terms; (b) the allocation of resources sufficient to comply with these Injunctive Terms; and (c) any revisions to the CSCP that the Controlled Substance Compliance Committee has approved. The Board of Directors or a committee thereof shall document in its minutes its review of the annual Controlled Substance Compliance Committee reports.
4. Walmart, through its Controlled Substance Compliance Department and Committee, shall, at least once every year, review and oversee any enhancements to the CSCP Policies and Procedures and systems for dispensing activity that the Controlled Substance Compliance Committee deems necessary.



5. The Controlled Substance Compliance Committee shall be responsible for the approval of all material revisions to the CSCP Policies and Procedures, provided that nothing herein shall prevent Walmart from implementing changes to the CSCP Policies and Procedures pending such review and approval.

## **VII. MANDATORY TRAINING**

1. The CSCP Policies and Procedures shall be published in a form and location readily accessible to all pharmacy and compliance personnel at each Walmart pharmacy location in the Settling States. Online availability is sufficient, so long as pharmacy and compliance personnel have access to a computer with access to the CSCP Policies and Procedures.
2. Walmart shall implement policies and procedures requiring that, to the extent practical (for example, accounting for employee leave), within 90 days of the Injunctive Terms Implementation Date, all existing CSCP Employees must complete a training on the CSCP Policies and Procedures required under these Injunctive Terms, including the Prescription Validation Process and their corresponding responsibility. These policies and procedures shall further require that all new hires must complete such trainings within 60 days of hiring or 6 months of the Injunctive Terms Implementation Date, whichever is later. Walmart will further ensure that every CSCP Employee will receive such training at least once every 3 years for the term of these Injunctive Terms.
3. On an annual basis for the duration of these Injunctive Terms, Walmart shall test its CSCP Employees on their knowledge regarding the CSCP Policies and Procedures required under these Injunctive Terms, including the Prescription Validation Process and their corresponding responsibility.
4. Walmart shall train all third-party compliance consultants performing CSCP-related compliance functions for Walmart in the same manner as Walmart's CSCP Employees.
5. It shall be a part of the CSCP Policies and Procedures and all trainings of all CSCP Employees required under these Injunctive Terms that pharmacists shall refuse to dispense Controlled Substances that they believe were prescribed or are being used for other than a legitimate medical purpose or that they believe were not prescribed by an individual Prescriber acting in the usual course of his or her professional practice.
6. All trainings required under these Injunctive Terms shall also make clear that i) Walmart's compensation and non-retaliation policies, including pursuant to these Injunctive Terms, prevent CSCP Employees from being compensated or penalized in any way related to revenue or profitability targets or expectations specific to sales of Controlled Substances; and ii) pharmacists will not be penalized in any way for exercising their professional judgment to refuse to fill prescriptions for Controlled Substances pursuant to their corresponding responsibility.

## **VIII. THE PRESCRIPTION VALIDATION PROCESS**

1. As part of its CSCP, Walmart shall maintain a Prescription Validation Process in the CSCP Policies and Procedures, as further described and set forth in this section, that each pharmacist employed by Walmart in a Settling State must follow when dispensing a prescription for a Controlled Substance. The inclusion of an enumerated Red Flag in these Injunctive Terms shall not be considered, construed, or represented to be an admission, concession, or evidence of any fact or contention related to such Red Flag. Nothing in these Injunctive Terms shall require Walmart to create a record in those instances where the pharmacist rejects a prescription when presented without an effort to resolve any red flags, including but not limited to instances where the pharmacist identifies on the face of the prescription a Prescription Red Flag (defined in Section IX below) that causes the pharmacist to conclude without further inquiry that the prescription is invalid.
2. A Red Flag will be considered “resolved” if, after further investigation as described below, and given other facts and circumstances surrounding the prescription, a pharmacist determines, in his or her professional judgment, that the facts that triggered the Red Flag do not lead him or her to believe that the prescription was written or is being submitted for an illegitimate medical purpose or outside the usual course of a Prescriber’s professional practice. All Red Flags described in Sections IX.3 and IX.5 below shall be based on internal Walmart dispensing data regarding prescriptions filled at Walmart pharmacies and shall not be based on Prescription Monitor Program (“PMP”) or Prescription Drug Monitoring Program (“PDMP”) data or dispensing data regarding prescriptions filled at pharmacies other than Walmart pharmacies. Nothing in this Agreement requires Walmart to use nor prohibits Walmart from using any data other than internal Walmart dispensing data to identify any Patient Red Flags or Prescriber Red Flags (described in Section IX.3 and IX.5 below).
3. Walmart’s CSCP Policies and Procedures shall provide that if a pharmacist identifies any “Patient Red Flags” associated with a Controlled Substances prescription (described in Section IX(3) below), before filling the prescription the pharmacist must resolve them; and that the method of resolution falls within the judgment of the pharmacist and may include reviewing the Patient’s profile and history with Walmart, calling the Prescriber or Prescribers if appropriate, speaking with the Patient if appropriate, calling on the pharmacist’s pre-existing knowledge of the Patient or Prescriber, reviewing available Prescription Monitoring Program (“PMP” or “PDMP”) data, and/or reviewing other data or information available to the pharmacist.

4. Walmart's CSCP Policies and Procedures shall provide that if forgery or fraud is suspected, or if the pharmacist identifies any other "Prescription Red Flags" associated with a Controlled Substances prescription (described in Section IX(4) below), the pharmacist must either reject the prescription if the pharmacist concludes without further inquiry that the prescription is invalid or resolve the Prescription Red Flags; and that the method of resolution falls within the judgment of the pharmacist and may include reviewing the Patient's profile and history with Walmart, calling the Prescriber or Prescribers if appropriate, speaking with the Patient if appropriate, calling on the pharmacist's pre-existing knowledge of the Patient or Prescriber, reviewing available PMP or PDMP data, and/or reviewing other data or information available to the pharmacist.
5. Walmart's CSCP Policies and Procedures shall require that if a pharmacist identifies any "Prescriber Red Flags" associated with a Controlled Substances prescription (described in Section IX(5) below), the pharmacist must resolve them; and that the method of resolution falls within the judgment of the pharmacist and may include reviewing any Walmart records regarding the Prescriber, calling the Prescriber if appropriate, speaking with the Patient if appropriate, calling on the pharmacist's pre-existing knowledge of the Patient or Prescriber, reviewing available PMP or PDMP data, and/or reviewing other data or information available to Walmart.
6. Walmart's CSCP Policies and Procedures shall provide that the resolution of all Red Flags identified by the pharmacist, as well as any Controlled Substance prescriptions that were rejected pursuant to the Prescription Validation Process, and the reasons why they were rejected, must be documented. Any such records shall be maintained for the duration of these Injunctive Terms. To the extent that a Red Flag is resolved based upon facts or circumstances that are already reflected or documented in Walmart's records, further documentation of those facts or circumstances is not required for resolution of substantially the same Red Flag on subsequent prescriptions. For example, if a patient lives 55 miles from a Walmart pharmacy but works near the pharmacy and that fact is reflected in pharmacy records, no documentation for the resolution of the Red Flag addressing patient distance from the pharmacy is required in connection with individual prescriptions dispensed for that patient.
7. Walmart's CSCP Policies and Procedures shall provide that, even if all Red Flags are resolved, a pharmacist shall reject a prescription if, in his or her professional judgment, he or she believes that it was written or is being submitted for other than a legitimate medical purpose and/or was written outside the usual course of an individual Prescriber's professional practice.

## **IX. RED FLAGS**

1. Walmart shall provide annually to the Settling States, beginning with an initial report twelve months after the Injunctive Terms Implementation Date, and annually

thereafter, a report (the “Annual Red Flag Report”) that sets forth: (a) the total number of prescriptions for Controlled Substances dispensed annually aggregated nationally and by state; (b) the specific metrics or algorithms (if any) used to identify each category of Red Flag listed in this section; and, (c) for each category of Red Flags (excluding the Prescription Red Flags in IX.4 except to the extent collected and maintained), the following information on both a nationwide basis and, separately, for each Settling State:

- a. The number of times that Walmart pharmacists input a prescription into its systems and identified the Red Flag during the prior year;
  - b. The number of times when such Red Flag was not resolved and thus, the prescription was refused, during the prior year;
  - c. The percentage of instances where a Red Flag occurred, as in subsection a, that the Red Flag was not resolved, as in subsection b.
2. Within the three months following the provision of the Annual Red Flag Report, either Walmart or the States Injunctive Relief Committee may propose in writing a meet and confer to discuss potential changes to the scope of one or more categories of Red Flags. At such a meeting, Walmart or the States Injunctive Relief Committee may provide additional research, information or data available to them beyond that provided in the Annual Red Flag Report. For example, Walmart might propose reducing the threshold for triggering a particular category of Red Flag or consolidating certain Red Flags or subcategories of Red Flags into a single metric, or the States Injunctive Relief Committee might propose increasing the threshold for triggering a particular Red Flag or expanding that Red Flag to include multiple subcategories (*e.g.*, number of prescriptions, distance thresholds).
- a. If Walmart and the States Injunctive Relief Committee agree on such changes to one or more Red Flags, they shall document those changes in writing and they shall become a part of these Injunctive Terms for all intents and purposes. Further, any modified Red Flags shall thereafter become subject to tracking by Walmart and part of the Annual Red Flag Report.
  - b. If Walmart and the States Injunctive Relief Committee cannot agree on the proposed changes during their meeting and confer, the Party seeking the change(s) to the Red Flag(s) may seek a 5-day mediation of the issue at its own expense. If the mediation fails to resolve the dispute between the parties, the party seeking the proposed change(s) may appeal to the National Arbitration Panel to have the National Arbitration Panel modify the Red Flags on the basis that the change(s) would be consistent both with avoiding unnecessary material costs of identifying and resolving Red Flags and materially reducing the diversion of Controlled Substances. In such a proceeding, the Party seeking the

proposed change(s) may provide evidence from Annual Red Flag Reports or from other research, data and information.

3. Walmart shall treat the following circumstances as “Patient Red Flags”:
  - a. A Patient seeks to fill a Schedule II Designated Controlled Substance prescription more than three days prior to the contemplated exhaustion date of more than two earlier prescriptions of the Schedule II Designated Controlled Substance (e.g., exhaustion of the days’ supply assuming the prescription has been taken in accordance with the prescribers’ directions on the face of the prescription);
  - b. A Patient seeks to fill a Designated Controlled Substance prescription from a Prescriber after having filled Designated Controlled Substance prescriptions from three other Prescribers, from separate practices, in a given 6-month period;<sup>1</sup>
  - c. A Patient seeks to fill a Designated Controlled Substance prescription after having filled Designated Controlled Substance prescriptions at two other Walmart pharmacies within 30 days;
  - d. A Patient seeks to fill a Designated Controlled Substance prescription after having filled three other Designated Controlled Substance prescriptions within 30 days;
  - e. The distance between a Patient’s residence and the Walmart pharmacy receiving the Designated Controlled Substance prescription is farther than 50 miles (except if the prescription is presented to Walmart’s mail-order pharmacy, in which case this Red Flag shall not be applicable);
  - f. The Patient resides more than 100 miles from the Prescriber who issued the Designated Controlled Substances prescription;
  - g. A Patient seeks to fill an acute-condition Designated Controlled Substance prescription for more than a seven-day supply or over 50 MME per day and has not filled an acute-condition Designated Controlled Substance prescription within the past 30 days; and
  - h. A Patient seeks to fill a Designated Controlled Substance prescription after having two other prescriptions for Designated Controlled Substances subjected to documented refusals to fill by a Walmart pharmacist within the past 30 days.
4. Walmart shall treat the following circumstances as “Prescription Red Flags:”

---

<sup>1</sup> In Walmart’s sole discretion, for administrative convenience Walmart may implement this Red Flag without regard to whether prescribers are at separate practices, thereby resulting in more instances in which the flag occurs.

- a. A Controlled Substance prescription that appears altered, including but not limited to, a photocopied prescription or a prescription in which an altering agent, such as white out, was used;
  - b. A Controlled Substance prescription written with misspellings suggesting the prescription may not have been written by a Prescriber;
  - c. A Controlled Substance prescription using atypical abbreviations suggesting the prescription may not have been written by a Prescriber; and
  - d. A Controlled Substance prescription written with multiple colors of ink or in multiple different handwritings.
5. Walmart shall treat the following circumstances as “Prescriber Red Flags:”
- a. A Prescriber provides a Patient with prescriptions for all three of a Schedule II Designated Controlled Substance, a benzodiazepine, and carisoprodol;
  - b. A Prescriber has no office within 50 miles of the retail pharmacy store where a Designated Controlled Substance prescription is submitted; and
  - c. A Patient seeks to fill a Designated Controlled Substance prescription written by a Prescriber after having filled at least seven Designated Controlled Substance prescriptions written by the same Prescriber within 90 days.

**X. PRESCRIBER REVIEW**

1. Walmart shall regularly review the prescribing patterns and practices of Prescribers of Designated Controlled Substances (the “Prescriber Review Process”). The Prescriber Review Process shall employ algorithms, or other means, to review data on Walmart’s retail dispensing for potential Prescribers of concern.
2. Walmart shall automatically refer a Prescriber for further investigation as part of the Prescriber Review Process in the following circumstances:
  - a. Personnel implementing the Prescriber Review Process become aware that a Prescriber has had his or her medical license suspended or revoked for violations of laws or regulations related to Controlled Substance prescribing in any jurisdiction of the United States within the prior six months;
  - b. A Prescriber has been the subject of a blanket refusal to fill;
  - c. A Prescriber has been the subject of more than ten (10) documented refusals to fill within a six-month period;

- d. Personnel implementing the Prescriber Review Process become aware that a Prescriber has been charged or indicted with a crime related to prescribing Controlled Substances by the Federal Government or in any jurisdiction of the United States; or
    - e. Walmart has received a Hotline complaint that has been investigated and substantiated concerning a Prescriber's illegitimate prescribing of Controlled Substances.
3. Based on the professional judgment of the employees operating the Prescriber Review Process, Walmart may also refer a Prescriber for further investigation as part of the Prescriber Review Process based on one of the following circumstances:
  - a. A Prescriber was the subject of an inquiry by law enforcement;
  - b. A Prescriber was flagged for review by a Walmart pharmacist (other than through a refusal to fill or blanket refusal to fill) or supervisory field personnel; or
  - c. A Prescriber was identified by review or analysis of objective data metrics, alone or in combination, such as data pertaining to the Prescriber's Controlled Substance prescription practices or patients.
4. Once Walmart identifies a Prescriber for further investigation, Walmart shall review pertinent and available data and information pertaining to the Prescriber, which may include interviews or other information gathered in the discretion of the employees operating the Prescriber Review Process. When permitted by law, nothing contained in this Section prevents Walmart from taking immediate action to Block a Prescriber in lieu of referral for further investigation or prevents a Walmart Pharmacist from refusing to fill any particular prescription or refusing to fill prescriptions from a given Prescriber.
5. If after the Prescriber Review Process those making the decision have not resolved the circumstances that caused Walmart to further investigate the Prescriber, then the Prescriber shall be Blocked and Walmart pharmacies will no longer fill controlled substance prescriptions written by that prescriber. If Walmart does not Block the Prescriber due to requirements of state law, Walmart shall provide notice to the Pharmacist that, but for this prohibition, the Prescriber would have been Blocked. A Prescriber may have an opportunity at the discretion of Walmart to seek future reinstatement by providing information to Walmart that may resolve its concerns. Nothing in this Section shall limit the right or ability of individual Walmart pharmacists to either refuse to fill a given prescription or refuse to fill all prescriptions for Controlled Substances from a given prescriber independent of any decision by Walmart to Block or not Block a given prescriber. Walmart shall provide the names of doctors

it has Blocked to the Board of Medicine in each Settling State.

6. Walmart shall report to each Settling State the number and identity of Prescribers from such Settling State that were Blocked and the number of Prescribers from such Settling State who were referred for a decision regarding whether the Prescriber should be Blocked as part of Walmart's Prescriber Review Process. Such reporting shall occur on an annual basis. Walmart may, at its discretion, report on a more frequent basis.

**XI. PROACTIVE DUE DILIGENCE AND SITE VISITS**

1. During the term of these Injunctive Terms, Walmart shall conduct periodic proactive compliance reviews of its retail pharmacy stores in the Settling States to assist with the identification of potential compliance issues related to the dispensing of Designated Controlled Substances at its retail pharmacy stores in the Settling States. This may be satisfied by the use of algorithms, or other electronic means, to analyze the data associated with each pharmacy to identify particular pharmacies for review as required under this Section XI. Documentation of any resulting reviews shall be maintained by Walmart and made accessible to all Controlled Substance Compliance Department personnel upon request for the duration of these Injunctive Terms.
2. During the term of these Injunctive Terms, Walmart personnel or qualified third-party compliance consultants shall also conduct site visits based on analysis of data regarding dispensing of Designated Controlled Substances at Walmart pharmacies, including unannounced site visits to at least one in every 50 of its retail pharmacy stores in each Settling State each year (but not less than five each year) for the duration of these Injunctive Terms. These site visits shall at a minimum consist of a review of Controlled Substance dispensing documentation and recordkeeping; a review of fraud, theft and loss prevention equipment and processes; an audit of Controlled Substances inventory and recordkeeping; and a review of physical surroundings and other circumstances for any indications of potential non-compliance with these Injunctive Terms or the CSCP Policies and Procedures, or any violations of other applicable laws and regulations related to Controlled Substances.
3. During site visits, Walmart personnel or qualified third-party compliance consultants shall interview relevant pharmacy employees, if appropriate, about any potential areas or issues of concern, including potential violations of law, the CSCP Policies and Procedures, and these Injunctive Terms, as well as the retail pharmacy store's maintenance of effective controls against the potential diversion of Controlled Substances.
4. Walmart personnel or qualified third-party compliance consultants who conduct site visits shall complete a report reflecting the findings of any site visit pursuant to this section. This report shall document areas or issues of concern, including potential



violations of law, the CSCP standard operating procedure, and these Injunctive Terms, and the results of any follow-up data analysis performed, as well as any other results or findings.

5. Site visit reports and all other compliance reports related to the dispensing of Designated Controlled Substances shall be maintained by Walmart and made accessible to all Controlled Substance Compliance Department personnel upon request for the duration of these Injunctive Terms.

## **XII. FRAUD, THEFT AND LOSS PREVENTION**

1. In addition to complying with all fraud, theft and loss procedures, policies and precautions required by state and federal law, Walmart shall maintain information regarding the inventory accounting and auditing of all Designated Controlled Substances at each retail pharmacy store for at least three years from the date of the accounting or audit.
2. In addition to any other reporting obligations under state and federal law, Walmart must provide to each Settling State on a quarterly basis any reports it has made to the Drug Enforcement Administration regarding the theft or significant loss of Controlled Substances in that Settling State pursuant to 21 CFR §1301.76(b).

## **XIII. REPORTING TO LAW ENFORCEMENT**

1. To the extent not already in place, Walmart shall implement standard operating procedures directing its employees to report any confirmed fraudulent or forged prescriptions to Settling State law enforcement authorities, to the extent they want to accept it, within 5 business days of completing any review of such prescription, and provide a summary of such reports, to the extent permitted by law, to the Settling State on a biannual basis upon request.
2. Walmart shall document and for at least 2 years maintain records of any such reports that are made to law enforcement regarding confirmed fraudulent or forged prescriptions.

## **XIV. ENFORCEMENT OF INJUNCTIVE TERMS**

1. Notice of Potential Violations and Opportunity to Cure.
  - a. A “Potential Violation” occurs when the Settling State determines, after appropriate investigation and due diligence, that Walmart is not in substantial compliance with a material aspect of the Injunctive Terms. A Potential Violation may be for a single retail pharmacy. A violation of this Agreement

does not necessarily occur when a pharmacist, pharmacist technician, or other field personnel who supervise pharmacists and/or pharmacist technicians employed by Walmart violates Walmart's CSCP Policies and Procedures or the law.

- b. Potential Violation Discovered by Settling State.
  - a. In the event of a Potential Violation identified by a Settling State, the Settling State shall notify Walmart in writing (the "State's Notice").
  - b. Within thirty (30) days of receipt of the State's Notice, Walmart shall provide a written response to the Settling State. The response shall include Walmart's position as to the act(s) of non-compliance, including, possibly, a statement setting forth why Walmart believes it is in substantial compliance with the relevant provision(s) or a statement explaining how the Potential Violation has been addressed.
  - c. If the Settling State wishes to meet with Walmart, Walmart shall promptly make itself available for such a meeting.
- c. If, after review of a written response and any meeting, the Settling State believes that a Potential Violation is ongoing or has not been substantially addressed, it will provide written notice to Walmart and work in conjunction with Walmart to devise, within thirty (30) days, a corrective action plan ("Corrective Action Plan") to remedy such Potential Violation, including a reasonable period for implementation of such plan.
- d. Within 60 and 120 days after implementing the Corrective Action Plan, Walmart will provide a written compliance update to the Settling State and make itself available to meet with the Settling State if requested. If after reviewing the compliance update and any meeting, the Settling State believes a Potential Violation remains ongoing or has not been substantially addressed, the Settling State may commence a 30-day mediation period. If mediation fails to resolve the dispute between the parties, the Settling State may take whatever action it deems necessary, including but not limited to bringing an action to enforce these Injunctive Terms, filing a new action (administrative or civil action) for violation of the Injunctive Terms as allowed by state law, conducting further investigation, or attempting to negotiate an updated Corrective Action Plan with Walmart. But the Settling State may not seek to reinstate claims that have been released as part of the Settlement.
- e. If Walmart fails or refuses to provide a written response, to devise or implement a Corrective Action Plan or to provide a compliance update as required by

subsections 1(b), 1(c) and/or 1(d), a Settling State may bring an action to enforce these Injunctive Terms, filing a new action (administrative or civil action) for violation of the Injunctive Terms as allowed by state law, conduct further investigation, or attempt to negotiate an updated Corrective Action Plan with Walmart. But the Settling State may not seek to reinstate claims that have been released as part of the Settlement.

- f. If, after review of a written response and any meeting, pursuant to subsections 1b. or 1c., above, the Settling State concludes that a Potential Violation is not ongoing or has been substantially addressed, the State will provide written notice of this conclusion to Walmart within 30 days of reaching its conclusion.
2. Enforcement Action. Each Settling State agrees that prior to taking any court or administrative action, other than an action that the Settling State concludes is necessary to address an immediate threat to the health, safety, or welfare of the citizens of the Settling State, or that a public emergency requiring immediate action exists, it will follow the process outlined above. If the Settling State concludes that action is necessary to address an immediate threat to the health, safety, or welfare of the citizens of the Settling State or that a public emergency requiring immediate action exists, it will make best efforts to provide reasonable notice to Walmart prior to initiating any such action.

## **XV. COMPLIANCE CERTIFICATION**

1. Walmart's Controlled Substance Compliance Director shall, after diligent inquiry, complete an annual compliance certification as set out in Section XV(4).
2. The certification shall be filed annually for the duration of these Injunctive Terms with a Settling State's appropriate licensing and/or regulatory agency and its Attorney General.
3. In addition to the responsibilities set forth in these Injunctive Terms, certain Walmart Pharmacy employees ("Certifying Employees") are expected to monitor and oversee activities within their areas of authority and beginning within 1 year of the Injunctive Terms Implementation Date shall annually certify that the applicable Walmart department is in compliance with applicable statutory requirements and the obligations of these Injunctive Terms. These Certifying Employees shall include, at a minimum, the following: Senior Vice President, Pharmacy; Vice President, Pharmacy Operations; Senior Vice President, Chief Financial Officer, Health & Wellness; and Chief Ethics and Compliance Officer, Health & Wellness. For each reporting period, each Certifying Employee shall sign a certification as set out in Section XV(4).
4. The certification shall state:

“I understand the compliance requirements and responsibilities as they relate to [insert name of department], an area under my supervision. My job responsibilities include attempting to ensure compliance with regard to the [insert name of department] with all applicable statutory requirements, obligations of the Injunctive Terms, and applicable policies, and I have taken steps to promote such compliance. To the best of my knowledge, the [insert name of department] is in compliance with the obligations of these Injunctive Terms. I understand that this certification is being provided to and relied upon by the State of [Settling State].”

5. If the Controlled Substance Compliance Director or Certifying Employee is unable to provide such a certification, the Controlled Substance Compliance Director or Certifying Employee shall provide a written explanation of the reasons why he or she is unable to provide the certification outlined above.
6. Within 120 days of the Injunctive Terms Implementation Date, Walmart shall develop and implement a written process for the Certifying Employees to follow for the purpose of completing the certification required by this section.

## **XVI. DATA SHARING**

1. Walmart shall consent to the provision by its distributors of Walmart’s unblinded “867 Data” (data sent from the distributor to the manufacturer concerning the sale of its products to Walmart) regarding Designated Controlled Substances to opioid manufacturers as soon as commercially reasonable and at no cost to the manufacturers, provided that, pursuant to a prior written agreement with Walmart, the opioid manufacturers agree (a) to ensure the confidentiality of the 867 Data; (b) to implement safeguards and procedures to limit access to and use of the 867 Data; (c) that the 867 Data shall be used solely for compliance purposes as part of their Suspicious Order Monitoring programs; and (d) that the 867 Data shall be shared only with specified personnel and shall not be shared with business or sales personnel.
2. To the extent that Walmart provides McKesson Corporation, Cardinal Health, Inc., or AmerisourceBergen Corporation (the "Settling Distributors") with Pharmacy Customer Data (as defined in the Distributor Injunctive Terms) for use in their Controlled Substance Monitoring Programs, Walmart agrees that the Settling Distributor(s) may share such Pharmacy Customer Data with the Monitor appointed pursuant to the Distributor Injunctive Terms, provided that the Monitor agrees, pursuant to a prior written agreement with Walmart, (a) to ensure the confidentiality of the Pharmacy Customer Data; (b) to implement safeguards and procedures to limit access to and use of the Pharmacy Customer Data; (c) that the Pharmacy Customer Data is used solely for the purpose of ensuring the Settling Distributors’ compliance with the Distributor Injunctive Terms; and (d) that the Pharmacy Customer Data shall be shared only with specified personnel.

## **XVII. CLEARINGHOUSE**

1. Solely for purposes of this Section XVII, the term “Pharmacy Clearinghouse Data” means aggregated data for a 90-day period that contains:
  - a. A list of the total number of prescriptions and dosage units for each NDC for all Controlled Substances dispensed at each Walmart retail pharmacy;
  - b. A list of the top five prescribers of each Designated Controlled Substance by dosage volume and the top ten prescribers of all Designated Controlled Substances combined by dosage volume dispensed at each Walmart retail pharmacy. For each prescriber, the data shall include the following information:
    - i. Number of prescriptions and doses prescribed for each Designated Controlled Substance NDC;
    - ii. Number of prescriptions for each unique dosage amount (number of pills per prescription) for each Designated Controlled Substance NDC;
    - iii. Prescriber name, DEA registration number, and address; and
    - iv. Medical practice/specialties, if available;
  - c. Information on whether the method of payment was cash for Controlled Substances prescriptions dispensed at each Walmart retail pharmacy; and
  - d. Information on top ten patient residential areas by five-digit ZIP code prefix for filled Designated Controlled Substances by dosage volume, including number of prescriptions and doses for each Designated Controlled Substance NDC dispensed at each Walmart retail pharmacy.
2. To the extent that a Settling Distributor distributes Controlled Substances to Walmart pharmacies, Walmart shall make Pharmacy Clearinghouse Data available to such Settling Distributor for provision to the Clearinghouse on a quarterly basis and Walmart will confer with such Settling Distributor(s) and the States Injunctive Relief Committee to determine: what additional information, if any, is needed from Walmart for a Settling Distributor to perform suspicious order monitoring, including in connection with the effective operation of the Clearinghouse to assist with suspicious order monitoring; if additional information is needed, how Walmart shall provide it to a Settling Distributor; and what information provided by Walmart to a Settling Distributor may be deposited by the Settling Distributor into the Clearinghouse. Due to patient privacy and legal restrictions, in connection with any meet and confer described above, Walmart will not agree to provide individual patient-level or prescription-level data, de-identified or otherwise, to the Settling Distributors and/or the Clearinghouse.
3. Walmart and Settling Distributors will also determine whether and in what amount Walmart will contribute financially to the Clearinghouse. Such contribution, if any, shall be in an amount proportionate to the contributions of other Chain Pharmacies based upon Controlled Substance market share, but in no event shall Walmart be

- obligated to contribute more than a total of \$7,000,000 for the life of the Clearinghouse. If Walmart contributes financially to the Clearinghouse and/or provides data directly to the Clearinghouse, it shall have the option, in its sole discretion, to have a seat on the Clearinghouse Advisory Panel with rights identical to those of the Settling Distributors. If Walmart becomes a member of the Clearinghouse Advisory, the number of state members shall remain equal to the number of non-state members
4. Any data provided by Walmart to a Settling Distributor and/or the Clearinghouse pursuant to these Injunctive Terms shall be treated in compliance with state and federal law, including but not limited to the Health Insurance Portability and Accountability Act of 1996 (“HIPAA”) and all applicable state and federal privacy laws.
  5. At Walmart’s sole option, Walmart may obtain relevant information, analyses, and reports from the Clearinghouse, subject to the following conditions:
    - a. Walmart shall be permitted to use information obtained from the Clearinghouse for anti-diversion purposes, including the uses expressly contemplated by the Injunctive Terms.
    - b. Walmart shall ensure any data obtained from the Clearinghouse cannot be accessed by any of its employees or agents who are involved in negotiating pricing or other business terms with pharmaceutical distributors or manufacturers.
    - c. No pharmacy shall receive from the Clearinghouse information specific to another pharmacy. Notwithstanding the prior sentence, Walmart may receive from the Clearinghouse blinded data.
    - d. Walmart may use information it receives from the Clearinghouse only for the purposes of identifying, minimizing, or otherwise addressing the risk of Controlled Substances diversion. Walmart shall not attempt to obtain revenue from this information.
    - e. Walmart shall not sell (or obtain license fees for) data obtained from Clearinghouse to any third-parties.
3. Liability Related to the Clearinghouse.
    - a. Walmart is entitled to rely upon information or data received from the Clearinghouse, whether in oral, written, or other form. Walmart shall not have any liability (whether direct or indirect, in contract or tort or otherwise) to any party for or in connection with any action taken or not taken by the Clearinghouse. In addition, Walmart shall not have any liability (whether direct or indirect, in contract or tort or otherwise) to any party for or in connection with any action taken or not taken by Walmart based on incorrect,

inaccurate, incomplete or otherwise erroneous information or data provided by the Clearinghouse, unless the information or data was incorrect, inaccurate, incomplete or otherwise erroneous because Walmart itself provided incorrect, inaccurate, incomplete or otherwise erroneous data or information to the Clearinghouse.

- b. Reports or analysis generated by the Clearinghouse may not be based on complete data due to a lack of participation by other pharmacies and distributors. As such, Walmart shall not be held responsible for actions or inactions related to reports and analysis prepared by the Clearinghouse which may be based on incomplete data due to a lack of participation by other pharmacies and distributors.
- c. Walmart shall not require any distributor to indemnify or otherwise be responsible to it for any claims resulting from the provision of data, including Pharmacy Clearinghouse Data, to the Clearinghouse, including, but not limited to, claims related to any data breaches occurring with the data transmitted to or maintained by the Clearinghouse. Nothing in these Injunctive Terms shall require Walmart to indemnify, or otherwise be responsible to, any pharmacy, distributor, or Walmart customer for any claims arising out of or resulting from the provision of data, including Pharmacy Clearinghouse Data, to the Clearinghouse, including, but not limited to, claims related to any data breaches occurring with the data transmitted to or maintained by the Clearinghouse.
- d. Walmart and the Settling States shall not be liable for any breaches of any databases maintained by the Clearinghouse. This does not excuse the Clearinghouse or its vendor(s) from compliance with all state and federal laws and regulations governing (1) the protection of personal information and protected health information, or (2) notifications relating to Data Security Events. Solely for purposes of this Section XVII, the term “Data Security Event” means any compromise, or threat that gives rise to a reasonable likelihood of compromise, by unauthorized access or inadvertent disclosure impacting the confidentiality, integrity, or availability of Pharmacy Clearinghouse Data.

**EXHIBIT Q**

**[Intentionally Omitted]**



## EXHIBIT R

### Agreement on Attorneys' Fees, Costs, and Expenses

This Agreement on Attorneys' Fees, Costs, and Expenses ("Fee Agreement") is entered between Walmart and the Plaintiffs' Executive Committee appointed in the multidistrict litigation in the Northern District of Ohio, *In re National Prescription Opiate Litigation*, No. 1:17-MD-2804 ("MDL PEC"), in connection with the Walmart Global Opioid Settlement Agreement ("Walmart Agreement"). This Fee Agreement becomes effective on the Effective Date of the Walmart Agreement or the date that the Consent Judgments anticipated under the Walmart Agreement become final in 25 Settling States (whichever is later).

#### **I. Definitions**

- A. This Fee Agreement incorporates all defined terms in the Walmart Agreement, unless otherwise defined herein, and shall be interpreted in a manner consistent with the Walmart Agreement.
- B. "*Applicant.*" Any Attorney or MDL Participating Counsel who seeks an award of attorneys' fees from the Attorney Fee Fund pursuant to the procedures established by the MDL Court and the Fee Panel.
- C. "*Attorney.*" Any of the following retained through a legal contingency fee or hourly fee contract: a solo practitioner, multi-attorney law firm, or other legal representative of a Participating Subdivision or MDL Participating Counsel. This does not include Subdivision in-house attorneys.<sup>1</sup>
- D. "*Attorney Fee Fund.*" An account consisting of funds allocated to pay attorneys' fees approved pursuant to Section II.B of this Fee Agreement established by Order of and under the ongoing jurisdiction of the MDL Court, as provided below.
- E. "*Common Benefit.*" Work performed for the benefit of all Participating Subdivisions and Tribal Nations, including, but not limited to, pretrial matters, discovery, trial preparation, trial, settlement negotiations, and all other work that advances the interests of the Participating Subdivisions.
- F. "*Common Benefit Fund.*" The sub fund of the Attorney Fee Fund described in Section II.C.
- G. "*Contingency Fee Fund.*" The sub fund of the Attorney Fee Fund described in Section II.D.

---

<sup>1</sup> For the avoidance of doubt, Nassau County and Suffolk County of New York are eligible to receive payment under the Walmart Agreement and thus the legal services provided to Nassau County and Suffolk County in its litigation against Walmart, which was resolved through a separate settlement agreement, shall be treated as a Qualifying Representation for purposes of this Agreement.

- H. “*Cost and Expense Fund Administrator.*” The administrator appointed by the MDL Court on August 12, 2021 (MDL Docket No. 3828), to administer the Cost Fund and its sub funds as provided in the Fee Agreement.
- I. “*Court Common Benefit Fund.*” The Common Benefit Fund established by the MDL Court in its orders of July 22, 2021, MDL Docket No. 3794, and May 9, 2022, MDL Docket No. 4428.
- J. “*Fee Entitlement.*” Any right, entitlement, or expectation, including but not limited to a fee contract, contingent fee contract, agreement, referral arrangement, co-counsel arrangement, State Back-Stop Agreement, or any other arrangement by which counsel could receive compensation or other consideration. For the avoidance of doubt, the scope of Fee Entitlement under paragraph II.G.3.a does not include any Attorneys’ fees associated with representation of a State.
- K. “*Fee Panel.*” The three-person panel appointed by the MDL Court on August 12, 2021 (MDL Docket No. 3828), to administer and make recommendations for the allocation and distribution of the Attorney Fee Fund and its sub funds as provided in the Fee Agreement.
- L. “*Later Litigating State.*” A State that first files a lawsuit bringing a Released Claim against a Released Entity after November 14, 2022.
- M. “*MDL Court.*” United States District Court for the Northern District of Ohio Eastern Division, Case No. 1:17-md-2804, Judge Dan Aaron Polster.
- N. “*MDL Expense Fund.*” The cost fund described in Section II.F below.
- O. “*MDL Participating Counsel.*” MDL Participating Counsel includes an attorney or firm authorized by MDL 2804 Lead Counsel to perform work for the Common Benefit of Participating Subdivisions. By way of example, it would include insurance counsel and appellant counsel.
- P. “*MDL PEC.*” The Plaintiffs’ Executive Committee appointed by the MDL Court.
- Q. “*Non-Participating Litigating Subdivision.*” A Litigating Subdivision that is not a Participating Subdivision.
- R. “*Non-Participating State.*” A State that is not a Participating State.
- S. “*Participating Litigating Subdivision.*” A Litigating Subdivision that is also a Participating Subdivision.
- T. “*Participation Agreement.*” An agreement executed by an Attorney that acknowledges the obligation to pay an appropriate MDL Common Benefit Assessment.

- U. “*Qualified Tribal Representation.*” Representation by an attorney of a Participating Tribal Government regarding Released Claims against Released Entities. Such counsel are eligible for Common Benefit Fee consideration. The Walmart Tribal Global Settlement provides for the contribution to the Common Benefit Fund as shall be determined by the MDL Court.
- V. “*Qualifying Representation.*” Legal services provided for representation of the MDL PEC or Participating Litigating Subdivision regarding Released Claims against Released Entities.
- W. “*State Back-Stop Agreement.*” Any agreement by a Settling State and private counsel for Participating Subdivisions in that State (or legislation enacted in that State) to provide, adjust, or guarantee attorneys’ fees and costs, whether from the Attorney Fee Fund or any other source recognized in the agreement or legislation.<sup>2</sup>
- X. “*Subdivision Cost and Expense Fund.*” The fund created to pay approved Subdivision and Tribal Nations costs and expenses as set forth in Section II.E.
- Y. “*Walmart.*” (i) Walmart Inc. and (ii) all of its respective past and present direct or indirect parents, subsidiaries, divisions, affiliates, joint ventures, predecessors, successors, and assigns.

## II. Fees and Costs

### A. Total Attorneys’ Fees and Costs

1. Total attorneys’ fees and costs to be paid by Walmart to Attorneys under this Fee Agreement shall be up to but in no event more than \$297,720,376.93, subject to the reductions and provisions set forth below. The total attorneys’ fees and costs consists of up to \$267,720,376.93 for the Attorney Fee Fund, as set forth in Section II, and \$30,000,000 in total for the Subdivision Cost and Expense Fund and MDL Expense Fund, as set forth in Sections II.E and II.F respectively.
2. If an Eligible State does not join the Agreement by the State Participation Date and is accordingly not a Settling State, the total attorneys’ fees and costs to be paid under this Fee Agreement by Walmart shall be reduced by twelve point four percent (12.4%) times the Remediation Payment amount that would have been allocated to that Non-Settling State as set forth in Section IV.B of the Walmart Agreement.
3. The total attorneys’ fees and costs to be paid under this Fee Agreement by Walmart shall also be reduced by the amount of the Contingency Fee Fund for Attorneys representing Litigating Subdivisions in any Settling State that continue

---

<sup>2</sup> Nothing herein shall be understood to indicate approval for additional State Back-Stop Agreements or modifications of existing State Back-Stop Agreements.

to pursue Released Claims (“*Non-Participating Litigating Subdivisions*”), as set forth in Section II.D.4 and II.H.7 below.

4. If Walmart settles with any Non-Settling State after November 14, 2022, and such settlement allows for the Subdivision(s) in such Non-Settling State to join the settlement, Walmart agrees to withhold from the attorney fee portion of such settlement a Common Benefit Fund assessment, to be deposited in the Common Benefit Fund, of 7.5% times the portion of the Remediation Payment that would have been due to such State if it had participated in the Walmart Settlement and been awarded its full portion of the Remediation Payment (the “*Walmart State Settlement CBF Assessment*”). If Walmart settles with any Subdivision(s) in a Non-Settling State other than in connection with a statewide settlement that includes the relevant State after November 14, 2022, then Walmart agrees to withhold from the attorney fee portion of such settlement a Common Benefit Fund assessment, to be deposited in the Common Benefit Fund, of 7.5% times the portion of the Remediation Payment that would have been due to such Subdivision under this Agreement (the “*Walmart Subdivision CBF Assessment*,” and, along with the Walmart State Settlement CBF Assessment, each a “*Walmart CBF Assessment*”). If (a) Walmart settles with a Non-Settling State after November 14, 2022, (b) such settlement does not allow for the Subdivision(s) in such Non-Settling State to join the settlement, and (c) Walmart later prevails in asserting that Released Claims of Primary Subdivisions in such Non-Settling State were released as a result of such settlement, Walmart agrees to deposit the Walmart State Settlement CBF Assessment in the Common Benefit Fund. Any Walmart CBF Assessment is inclusive of any assessment related to such settlement that would be required by the Ongoing Common Benefit Order (Dkt. #4428) in *In re National Prescription Opiate Litigation*, Case No. 1:17-md-2804. To the extent that Walmart is required to pay any additional and/or separate assessment on such settlement as a result of the Ongoing Common Benefit Order, the Walmart CBF Assessment shall be reduced by the amount required to be paid pursuant to the Ongoing Common Benefit Order.

*B. Attorney Fee Fund and Sub Funds*

1. The Attorney Fee Fund shall consist of the Contingency Fee Fund and the Common Benefit Fee Fund.

2. There shall be a split of the Attorney Fee Fund into the Contingency Fee Fund and the Common Benefit Fund. The split shall be 40% to the Contingency Fee Fund and 60% to the Common Benefit Fund. The Cost Funds shall include the MDL Expense Fund, and the Subdivision Cost and Expense Fund. The State Counsel Fee Fund and the State Cost Fund shall be separate funds under the control of the Settling States.

3. The Contingency Fee Fund and the Common Benefit Fund shall be administered by a Fee Panel to be appointed by the MDL Court that will be governed by the provisions of this Fee Agreement and shall design the process

and procedures for the allocation of fees pursuant to this Fee Agreement and the MDL Court's Order. The Cost Funds shall be administered by the Cost and Expense Fund Administrator to be appointed by the MDL Court who will be governed by the provisions of this Agreement and shall design the process and procedures for the allocation of costs pursuant to this Agreement and the MDL Court's Order.

4. The fees to be paid under this Fee Agreement are available for Attorneys engaged in Qualifying Representations and Qualified Trial Representations only. Fees to be paid under this Fee Agreement are not available prior to the Effective Date of the Walmart Agreement. Fees to be paid under this Fee Agreement are not available for representation of States, Non-Participating Subdivisions or Non-Litigating Subdivisions and are not available for representation of private hospitals, third-party payors, NAS claimants, personal injury/wrongful death claimants, or any entity other than Participating Litigating Subdivisions. In addition, fees under this Fee Agreement are not available for representation of any individual or entity in matters other than those claims against Released Entities, but may include a reasonable share of representations that involve development of facts for pursuit of opioid-related claims against multiple defendants in the pharmacy, manufacturing, and distribution chain.

5. In no event shall Walmart be required to pay more into the Attorney Fee Fund than the maximum amount specified in paragraph II.A.1. The amounts allocated to the Contingency Fee Fund and the Common Benefit Fund set by the Fee Panel shall be subject to the reductions set forth in Section II.A.2 and the reductions and refunds set forth below.

6. Awards of fees from the Contingency Fee Fund shall be available to Attorneys with Qualifying Representations of Participating Litigating Subdivisions eligible to receive an allocation under the Walmart Agreement, as set forth in Exhibit G to the Walmart Agreement, and shall be made by applying the Mathematical Model attached as Exhibit "A" to this Fee Agreement. The collection of the data and calculations for the Mathematical Model has been a cooperative effort among private counsel for a large number of Litigating Subdivisions. The analysis has been spearheaded by Joseph Tann and Andrew Arnold. The Fee Panel is encouraged to continue working with those counsel in application of the Model. The Fee Panel shall oversee the application of the Model and resolve any questions or disputes concerning the eligibility of a Counsel to participate as required in Section II.G. The Panel is empowered to hear disputes concerning and ensure the accuracy of the mathematical calculation.

7. As to awards from the Contingency Fee Fund, there shall be no right of appeal.

8. Any appeal of an award of the Fee Panel from the Common Benefit Fund will be made to the MDL Court and be reviewed under an abuse of discretion standard.

C. *Common Benefit Fund* (60% of the Attorney Fee Fund.)

1. Walmart shall pay the entirety of the Common Benefit Fund payments into the Attorney Fee Fund within fifteen (15) calendar days of the Effective Date of the Walmart Agreement, subject to the reductions set forth in Section II.A.2 and the adjustments set forth below.
2. The Common Benefit Fund shall be available to compensate Attorneys engaged in Qualifying Representations of Participating Litigating Subdivisions and Qualified Tribal Representation of Tribal Participating Governments who:
  - a. have performed work for the Common Benefit of all Participating Subdivisions and/or Tribal Nations consistent with the provisions to the guidelines established by Judge Polster set forth in MDL 2804 and the Order dated May 1, 2018, under docket number 358, which is included herein by reference; and
  - b. satisfy the eligibility criteria set forth in Section II.G.

For purposes of Common Benefit Fund distribution, notwithstanding paragraph II.A.5, Attorneys representing Tribal Nations litigating against Walmart have also reached a settlement for Released Claims with Walmart, and these settlements are the subject of agreements with Walmart. Attorneys are eligible for Common Benefit consideration provided such agreement with Walmart became effective under their terms. Such Attorneys must meet the eligibility criteria in Section II.G.

For purposes of Common Benefit Fund distribution, notwithstanding paragraph II.A.5, MDL Participating Counsel not engaged in Qualifying Representations of Participating Litigating Subdivisions but who performed work for the Common Benefit pursuant to authorization from the MDL Co-Leads and meet the eligibility criteria in Section II.G shall be eligible.

3. The Common Benefit Fund shall be overseen by the Fee Panel, which shall determine the allocation of funds to eligible Attorneys consistent with this Fee Agreement and the May 1, 2018 Order.
4. In assessing the benefits that an Applicant has conferred to Participating Subdivisions (including non-Litigating Subdivisions) and/or Tribes for

purposes of any compensation decision, the Fee Panel shall give significant weight to the extent to which (i) the Applicant and his or her clients have contributed to increasing (or reducing) Subdivision Participation in the Walmart Agreement as of the Threshold Subdivision Participation Date, and (ii) the Applicant and his or her clients have contributed to increasing (or reducing) the amounts achieved under Incentive Payments A-D through participation in the Walmart Agreement, including the Walmart Tribal Agreement. The Fee Panel shall also consider additional fee recoveries the Applicant may potentially obtain, including, but not limited to, from attorney fee funds under other Settlement Agreements, State Back-Stop Agreements, representations of States or Tribal Nations, representations of other clients in opioids-related matters, or through the representation of Subdivision clients, whether they participated in the Walmart Agreement or not. It is the intent of this provision to recognize that the goal of the Walmart Agreement is to provide for maximum participation by the Subdivisions, maximum abatement funding for all Subdivisions nationally, and the maximum peace for Released Entities. Therefore, representing a Non-Participating Subdivision does not further the goal of the Walmart Agreement, and should not be considered Common Benefit because it does not increase funds available to Participating Subdivisions' abatement programs. Representing Later Litigating Subdivisions or Later Litigating States is antithetical to the Walmart Agreement and detracts from Common Benefit. The Fee Panel shall consider this concept of "common detriment" set forth in this paragraph in all of its decision making with respect to the allocation of the Attorney Fee Fund among Applicants, as well as, in its discretion, any refunds provided to Walmart as set forth in Section II.H. The Fee Panel shall consider the totality of the Applicant's Participating Litigating Subdivisions as compared to the Applicant's Non-Participating Litigating Subdivisions; the Parties recognize that, although the goal is for 100% participation, Applicants with a greater number of clients have a greater probability of having one or more Non-Participating Litigating Subdivision. As used in this paragraph II.C.4, "client" or "representing" a Subdivision shall include any Litigating Subdivision as to which the Applicant has a Fee Entitlement.

5. As set forth in Section II.H, the Fee Panel must consider the factors described in paragraph II.C.4 to determine how and whether to allocate funds among Applicants and to determine the amounts to refund to Walmart. Any reduction to an Applicant not refunded to Walmart shall be allocated to attorneys whose Litigating Subdivision clients participated in the settlement by the Threshold Subdivision Participation Date.

*D. Contingency Fee Fund. (40% of the Attorney Fee Fund.)*

1. Walmart shall pay the entirety of the Contingency Fee Fund payment into the Attorney Fee Fund within fifteen (15) calendar days of the Effective Date of the Walmart Agreement, subject to the reductions set forth in Section II.A.2 and the adjustments set forth below.

2. The Contingency Fee Fund shall be available to compensate Attorneys engaged in Qualifying Representations of Participating Litigating Subdivisions that meet the criteria set forth in Section II.G.
  - a. The Contingency Fee Fund shall be available to Attorneys who represent Litigating Subdivisions that are Participating Subdivisions, whether their actions are filed in state or federal court, and meet the eligibility criteria of Section II.G.
  - b. Participation in the Contingency Fee Fund by counsel that have a case that is not subject to the jurisdiction of the MDL Court shall not create, provide, or waive jurisdiction of the MDL Court over that Litigating Subdivision, that case or Attorneys, other than to oversee the fairness of the distribution process, and enforcement of this Fee Agreement.
3. The amount owed by Walmart to the Contingency Fee Fund shall be reduced to reflect the non-joinder of Litigating Subdivisions in Settling States by subtracting the amounts identified by the Fee Panel, pursuant to paragraph II.H.7, that would have been owed to counsel for Non-Participating Litigating Subdivisions in Settling States had such Litigating Subdivisions been Participating Subdivisions. The Fee Panel shall remit payment to Walmart from the Contingency Fee Fund for any amounts corresponding to such reductions.
4. In the event that after the date of the Walmart Agreement, Walmart, prior to the Effective Date of the Walmart Agreement, settles with any Litigating Subdivision that would have been eligible to participate in the Settlement Agreement, and, under such settlement agreement pays attorneys' fees, the Fee Panel shall treat those Litigating Subdivisions as Participating Litigating Subdivisions and, applying the same criteria applicable to all Attorneys for Participating Litigating Subdivisions, determine what amount they would have been paid from the Contingency Fee Fund if they had become Participating Subdivisions under the Walmart Agreement without such prior settlement. That sum, rather than being paid to the Attorney for the previously settling Litigating Subdivision, shall be returned to Walmart, except that such refund shall not be greater than the amount paid to the Attorneys under the Litigating Subdivision's prior settlement agreement.

E. *Subdivision Cost and Expense Fund*

1. Walmart shall pay \$22,500,000 into the Subdivision Cost and Expense Fund.
2. The Subdivision Cost and Expense Fund shall be available to compensate Attorneys for costs and expenses arising out of representation of Participating Litigating Subdivisions. No funds in the Subdivision Cost and Expense Fund



may be used to compensate the costs incurred by Non-Participating Subdivisions or Non-Litigating Subdivisions or costs and expenses arising out of representation of any such Subdivision. In allocating the Subdivision Cost and Expense Fund, the Administrator shall not allocate any funds for costs incurred after November 14, 2022.

3. During the period between November 14, 2022 and the Effective Date, the MDL PEC, as well as Litigating Subdivisions eligible to claim costs from the Subdivision Cost and Expense Fund shall make best efforts to cease litigation activity against Walmart, including by jointly seeking stays or severance of claims against Walmart, where feasible, or postponements if a motion to stay or sever is not feasible or is denied, so long as such actions are not otherwise detrimental to the Litigating Subdivision.

4. In the event that Walmart, prior to the Effective Date of the Walmart Agreement, settles with any Litigating Subdivision and, under such settlement agreement pays costs to the Litigating Subdivision or its Attorney, the MDL Cost and Expense Fund Administrator shall treat those Litigating Subdivisions as Participating Litigating Subdivisions and, using the same criteria applicable to all applicants to the Subdivision Cost and Expense Fund, determine what amount in costs the Litigating Subdivision or its Attorney would have been paid from the Subdivision Cost and Expense Fund if they had settled under the Walmart Agreement. That sum, rather than being paid to the Attorney or the previously settling Litigating Subdivision, shall be credited and/or returned to Walmart, except that such sum shall not be greater than the amount paid under the previously settled Litigating Subdivision's settlement agreement.

5. The Cost Fund shall be administered by the Cost Fund and Expense Fund Administrator (MDL Docket No. 3828), who will be governed by the provisions of this Agreement and shall design the process and procedures for the allocation of costs pursuant to this Agreement and the MDL Court's Order.

6. The costs of the Cost and Expense Fund Administrator shall be paid from the Cost Fund and allocated by the Cost and Expense Fund Administrator between the MDL Direct Cost Fund and the Subdivision Cost and Expense Fund to fairly charge each fund the cost incurred in implementing and supervising the specific fund.

7. The Cost and Expense Fund Administrator shall set the process and procedures for submission of and criteria for applications for payment of Subdivisions' and Tribal Nations' costs and expenses. The Cost and Expense Fund Administrator shall receive and evaluate applications from Participating Litigating Subdivisions and litigating Tribal Nations, whether filed in Federal Court or State Court, to seek reimbursement for eligible costs under Section II.E.2 in pursuit of claims against Walmart. The process shall require a showing that the costs or expenses sought were reasonably incurred in furtherance of active litigation of a designated state or federal bellwether trial-set case, or Common Benefit. The Cost and Expense Fund Administrator shall require transparency from all applicants as to any other sources for compensating Attorneys for Subdivisions and Tribal Nations for costs incurred. If funds remain after the reimbursement of approved out-of-pocket costs, the Cost and Expense Fund Administrator may consider reasonable and appropriate payment for client time, costs, or expenses incurred by recognized trial bellwether plaintiffs. At the conclusion of the process, any funds not allocated by the Cost and Expense Fund Administrator shall be transferred to the Common Benefit Fund established in this Exhibit R.

8. In the event that States and Subdivisions enter into an additional global settlement with a party or parties other than Walmart that is (a) under the jurisdiction of the MDL Court in MDL No. 2804, (b) creates a separate cost fund, and (c) unless the parties agree to another date, such agreement has an effective date prior to June 30, 2023, the Cost and Expense Fund Administrator shall have the authority to aggregate the Cost Fund with the cost fund created under that global settlement agreement. The Cost and Expense Fund Administrator shall have the authority to address the appropriate procedures and required information to allow the costs to be funded from the appropriate cost fund or shared by two or more cost funds; *provided, however*, that the Subdivision Cost and Expense Fund shall remain subject to the requirements set forth in Section II.E.2. For the avoidance of doubt, the Subdivision Cost and Expense Fund is available only to compensate Attorneys for costs and expenses arising out of representation of Participating Litigating Subdivisions and no funds in the Subdivision Cost and Expense Fund may be used to compensate the costs incurred by Non-Participating Subdivisions or Non-Litigating Subdivisions or costs and expenses arising out of representation of any such Subdivision.

F. *MDL Expense Fund*

1. Walmart shall pay \$7,500,000 into the MDL Expense Fund.

2. The MDL Expense Fund shall be released following the Effective Date of this Fee Agreement without any delay to reimburse the MDL Counsel for an agreed-to portion of the expenses incurred, as approved by the Cost and Expense Fund Administrator. The sum deposited into the MDL Expense Fund will be paid directly to the MDL Cost Account, set up by MDL Order and will be administered under the ongoing jurisdiction of the MDL Court, as provided

below. No funds may be used to compensate the costs incurred by Non-Participating Subdivisions or to compensate any Attorney for costs incurred in representing one or more Non-Participating Subdivisions.

3. In allocating the MDL Expense Fund, the Administrator shall not allocate any funds for costs incurred after November 14, 2022, unless the Administrator determines that there are sufficient funds to cover all subdivision costs incurred prior to November 14, 2022 and that special circumstances exist to justify costs incurred following the public announcement of the Walmart Agreement, including reasonable costs related to the implementation of the Walmart Agreement.

*G. Eligibility*

1. It is the intention of all parties participating in the Fee Panel process that there should be total transparency to the Fee Panel and to all fund participants. In connection with the process to be developed by the Fee Panel, any and all monies in attorney's fees received or awarded, including prior or future Contingency Fees, Common Benefit Fees, referral fees, expenses paid, promises for payment, or any other Fee Entitlement, to any Applicant in any opioid litigation shall be disclosed to the Fee Panel as a condition of participating in the Attorney Fee Fund and prior to an award from the Fee Panel. Any payment, expectation of payment or perceived entitlement to participate in a State Back-Stop Agreement or any other agreement reached with a Settling State or any Subdivision or any other source regarding payment of fees must be disclosed to the Fee Panel. Similarly, any right to payment from any other fund, for example a fund for payment to lawyers representing Settling States or Tribal Nations or Subdivisions shall be disclosed to the Fee Panel. Because it is anticipated that there will be multiple firms listed on contingent fee agreements with Litigating Subdivisions, the Fee Panel shall establish procedures, with input from Attorneys for Participating Litigating Subdivisions, for which party or parties should petition for fees from such groups and to whom the fee shall be paid and thereafter distributed to co-counsel in accordance with applicable agreements. For the avoidance of doubt, all Attorneys that are part of such groups must meet the eligibility criteria in paragraph II.G.3, must be subject to the criteria set forth in paragraph II.C.4, and must be disclosed to the Fee Panel.
2. An Applicant may apply for and recover attorneys' fees from the Common Benefit Fund, the Contingency Fee Fund, and any fund created by a past or future State Back-Stop Agreement, provided the Applicant satisfies the requirements relevant to each such fund and requirements for disclosure to the Fee Panel.
3. An Attorney may not receive any payment from the Attorney Fee Fund (which includes both the Contingency Fee Fund and the Common Benefit

Fund) unless the following eligibility criteria are met and annually certified by the Attorney:

- a. The Attorney must expressly waive the enforcement against the Litigating Subdivision client of all Fee Entitlements (other than under State Back-Stop Agreements) arising out of or related to any or all Qualifying Representations of any Participating Litigating Subdivision prior to applying for attorneys' fees from the Attorney Fee Fund. All applications for attorneys' fees under this Fee Agreement shall include an affirmation by the Attorney of such waiver and notice to the client(s) of such waiver. Such waiver shall not preclude the Attorney from submitting such Fee Entitlements to the Fee Panel as a factor for consideration in allocating payments from the Attorney Fee Fund or in connection with a State Back-Stop Agreement. For the avoidance of doubt, no Attorney may recover fees under this Fee Agreement unless the Attorney expressly agrees not to enforce Fee Entitlements as to each and every Participating Litigating Subdivision represented by that Attorney, but such Attorneys may participate in and receive funds from a State Back-Stop Agreement.
- b. The Attorney must represent that s/he has no present intent to represent or participate in the representation of any Later Litigating Subdivision or Later Litigating State with respect to Released Claims against Released Entities.
- c. The Attorney must represent that s/he has not and will not engage in any advertising or solicitation related to Released Claims against Released Entities where such advertising or solicitation relates to a representation of a Subdivision eligible to be a Participating Subdivision after the Threshold Subdivision Participation Date.
- d. The Attorney must represent s/he will not charge or accept any referral fees for any Released Claims brought against Released Entities by Later Litigating Subdivisions or Later Litigating States. This representation shall not prohibit Attorneys from receiving allocated shares of any future common benefit assessments arising out of settlements or judgments with Later Litigating Subdivisions or Later Litigating States that are the result of the MDL Court's Common Benefit Order.
- e. The Attorney may not have and must represent that s/he does not have a Fee Entitlement related to a Later Litigating Subdivision or Later Litigating State, other than a potential Common Benefit Fee.
- f. The Attorney must fully disclose the participation, or the anticipation of participation, in any agreement with a Settling State or Participating Subdivision concerning fees arising out of or related to the Walmart

Agreement, including any fees paid or anticipated to be paid or any State Back-Stop Agreement.

- g. The Attorney must identify for the Fee Panel whether s/he utilized state litigation work product or MDL work product, including but not limited to ARCOS data, document repositories, experts developed in the MDL, trial transcripts, or deposition transcripts. The Attorney must identify whether s/he signed the MDL Participation Agreement.
  - h. Any Attorney who applies for fees from one or both Funds must represent that, having exercised his/her independent judgment, s/he believes the Walmart Agreement to be fair and will make or has made best efforts to recommend the Agreement to his or her Subdivision clients in Settling States. For avoidance of doubt, each Attorney is expected to exercise his or her independent judgment in the best interest of each client individually before determining whether to recommend joining the settlement. All applications for attorneys' fees or costs under this Section shall include an affirmation by the Attorney in compliance with this Subsection.
4. No Attorney receiving fees under this Fee Agreement may apply for or recover from the Attorney Fee Fund fees arising from representing a Non-Settling State or a Non-Participating Subdivision, provided, however, that this provision is not intended to prohibit Attorneys who do not represent or otherwise have a contractual agreement with such Non-Settling State or Non-Participating Subdivision from receiving allocated shares of any future common benefit assessments that arise out of settlements or judgments involving such Non-Settling State or Non-Participating Subdivision. All applications for attorneys' fees under this Section shall include an affirmation by the Attorney of compliance with this Section.
  5. An Attorney who has filed an application under this section and received an award of attorneys' fees shall provide a certification of compliance with the Sections of this Fee Agreement annually during the years upon which they are still entitled to receive attorneys' fee payments under this Agreement. This certification will be done as directed by the Panel.
  6. If, at any time, the Attorney is unable to make the representations set forth in this Section, such representations become untrue, or the Attorney falsely represents compliance with the eligibility criteria, the Attorney shall cease to be eligible to receive funds from the Attorney Fee Fund until further review by the Fee Panel of the Attorney's eligibility under and compliance with this Section II.
  7. If an Attorney has a Fee Entitlement with a Later Litigating Subdivision or Later Litigating State or otherwise becomes unable to reaffirm compliance with the eligibility criteria set forth above, the Attorney shall notify Walmart

and the Fee Panel. For the avoidance of doubt, any Attorney who undertakes any new representation of, or has a Fee Entitlement with, a Later Litigating Subdivision or Later Litigating State shall be prohibited from receiving any future funds from the Attorney Fee Fund and be subject to additional obligations as set forth in Subsection 8 below. If an Attorney fails to notify Walmart and the Fee Panel of such Fee Entitlement with a Later Litigating Subdivision or Later Litigating State, the Attorney shall be required to refund amounts previously paid. The Fee Panel shall notify Walmart when it receives notification.

8. To the extent an Attorney who has received compensation from the Attorney Fee Fund based on Qualifying Representations of Participating Litigating Subdivisions under the Walmart Agreement represents a Later Litigating Subdivision or Later Litigating State, such Attorney shall be obligated to refund such amounts received as compensation from the Attorney Fee Fund to Walmart. Walmart or such Attorney may bring any dispute as to whether such Attorney shall be obligated to refund such amounts received from the Attorney Fee Fund to Walmart to the Fee Panel. Nothing herein shall require a multi-attorney law firm that has received compensation from the Attorney Fee Fund to refund such amounts if an attorney of the firm that is no longer affiliated with such law firm, after such departure, represents a Later Litigating Subdivision or Later Litigating State, provided that (a) neither the law firm nor any of its other attorneys have any contractual or financial arrangement regarding, stand to benefit directly or indirectly from, or directly or indirectly provide financial or other support of any kind to, the former attorney's representation of the Later Litigating Subdivision or Later Litigating State and (b) if the former attorney was a partner or owner of the multi-attorney law firm at the time that the law firm received compensation from the Attorney Fee Fund, the former attorney shall be obligated to refund such amounts as the former attorney earned as a result of the compensation that the law firm received from the Attorney Fee Fund.
9. In the event that an Attorney is deemed ineligible by the Fee Panel (whether based on its initial application or subsequent recertification), the Fee Panel shall provide notice to the Attorney and give the Attorney 30 days to provide additional information such that the Fee Panel could re-consider the Attorney's eligibility.
10. To the extent that an Attorney has a Fee Entitlement with a Participating Subdivision and is authorized to bring Released Claims against Released Entities, but such authorization is, in scope, less broad than the category of Released Claims set forth in the Walmart Agreement, such Attorney may participate fully in both the Contingency Fee Fund and the Common Benefit Fund, without any reduction imposed by the Fee Panel due to the scope of the authorization, so long as the Participating Subdivision fully releases all Released Claims against Released Entities.

11. Attorneys applying to the Attorney Fee Fund knowingly and expressly agree to be bound by the decisions of the Fee Panel, subject to the limited appeal rights set forth in this Fee Agreement, and waive the ability to assert the lack of enforceability of the allocation reached through the procedures outlined herein.
12. Applicants are under an ongoing obligation to inform the Fee Panel in writing of any additional fees earned, expected, or received related to any Opioid litigation throughout the period of the Fee Panel's operation.

*H. Calculation of Amounts Due.*

1. The Fee Panel shall be solely responsible for determining the amount of fees to be paid to each Applicant. None of the Released Entities shall have any responsibility, obligation, or liability of any kind whatsoever with respect to how attorneys' fees are calculated under this Section, except that the Fee Panel may receive information from Walmart as to (a) the identity of Participating, Non-Participating, Litigating, Later Litigating, and Non-Litigating Subdivisions; (b) the impact of non-participation by a Litigating Subdivision as is relevant to the Fee Panel's determination in paragraph II.C.4; and (c) such other information as Walmart may voluntarily elect to provide.
2. The Fee Panel shall establish procedures for making determinations under this Fee Agreement consistent with this Fee Agreement and orders of the MDL Court. Such procedures may include submission of documentary and/or other evidence, interviews with Applicants and/or other counsel (including counsel for Walmart) that the Fee Panel deems appropriate, and/or other means of creating a record upon which fee awards will be based.
3. In making determinations under this Fee Agreement, the Fee Panel must apply the eligibility criteria set forth in Section II.G of this Fee Agreement and the criteria set forth in Section II. The Fee Panel shall ensure that payments are only made for Qualifying Representations of Participating Litigating Subdivisions. In addition, the Fee Panel will give consideration in regard to Common Benefit Fund awards to the *Johnson* factors, as well as the following factors (which factors may be applied and given relative weight in the Fee Panel's discretion):
  - a. The Applicant's contemporaneously recorded time and labor dedicated to Qualifying Representations along with the Applicant's financial commitment to such Qualifying Representations. Claimed "time" will not be automatically accepted by the Fee Panel but will be critically reviewed and given substantially more weight and consideration if such time was subject to the audit process described in any Pretrial Order(s) governing the collection of common benefit time;

- b. The novelty, time, and complexity of the Qualifying Representations;
- c. The skill requisite to perform legal services properly and undesirability of the case;
- d. The preclusion of other employment by the Applicant due to time dedicated to Qualifying Representations;
- e. The Common Benefit, if any, alleged to have been conferred by the Applicant and whether such Common Benefit work product by that Applicant was used by others in parallel litigations against Released Entities whether within or outside the MDL, provided that any Applicant claiming that s/he substantially benefited cases other than those in which s/he entered an appearance as counsel must substantiate such claims by proffering factual support, such as proper supporting affidavits or other documents as determined by the Fee Panel with input from Attorneys for Participating Litigating Subdivisions;
- f. Any “common detriment,” as set forth in paragraph II.C.4;
- g. Any contingent fee agreement or other Fee Entitlement with Participating Subdivisions, enforcement of which, except for State Back-Stop Agreements, are waived in conjunction with the application, the nature and extent of any work for those Participating Subdivisions, whether such Participating Subdivisions actively litigated and, if so, the nature and procedural history of such case(s);
- h. The experience, reputation, and ability of the Applicant;
- i. Whether the Applicant’s clients brought Released Claims against Released Entities;
- j. The status of discovery in cases primarily handled by the Applicant;
- k. The nature of any work by the Applicant on “bellwether” cases or cases that were similarly active in litigation;
- l. Any pressure points successfully asserted by the Applicant in cases against Walmart or any risk for Walmart created by the Applicant in cases against Walmart;
- m. Any risk for defendants created by Applicants in cases against Walmart;
- n. Successful and unsuccessful motion practice in cases worked on by the Applicant;



- o. The date of filing of any cases filed by the Applicant;
  - p. Obtaining consolidation of the litigation in the Applicant's jurisdiction;
  - q. The number and population of entities represented by the Applicant and the fees that would have been awarded under extinguished contingent fee arrangements;
  - r. Whether the Applicant's clients brought claims against Walmart prior to the announcement of this settlement on November 14, 2022;
  - s. Whether the Applicant has had a leadership role in the litigation, whether in state or federal court;
  - t. Whether the Applicant has had a leadership role in any negotiations aimed at resolving the litigation;
  - u. Whether the Applicant's cases have survived motions to dismiss;
  - v. The extent to which the Applicant contributed to the work product used for the common benefit of opioids litigants, including, without limitation, work on ARCOS data, Prescription Data Monitoring Programs, IQVIA data, depositions, document production and analysis experts, motions, briefs and pleadings, trial preparations, and trials;
  - w. The extent to which litigation occurred prior to and contributed to completion of settlement negotiations, as distinct from litigation that occurred after the announcement of the Walmart Agreement on November 14, 2022, such latter litigation both being of less value and, the case of litigation filed after the announcement of the Walmart Agreement on November 14, 2022, resulting in a common detriment to the settlement process, which in both cases should be viewed less favorably; and
  - x. Any other factors that the Fee Panel finds to be appropriate to consider after input from Applicants to the Attorney Fee Fund.
4. It is possible that the States and Subdivisions that are litigating Opioid cases will enter additional settlements in close proximity of the time for processing the Walmart Settlement. If there are additional settlements and these settlements create a Common Benefit Attorney Fee Fund to be administered by the Fee Panel, the Fee Panel may:
- a. Consolidate the Common Benefit approval process to include evaluation of all Common Benefit Applications for all settlements entered after November 14, 2022;

- b. Determine the fair and equitable allocation of the Aggregate Common Benefit Fees that come after November 14, 2022, including consideration of beneficial or detrimental actions taken with respect to any Settling Defendant contributing to the Common Benefit Attorney Fee Fund;
  - c. Give consideration to the amount and timing of each settlement, including the amount and timing of Common Benefit Fees;
  - d. The Fee Panel shall abide by the applicable Attorney Fee Agreement in each of the Settlements in Allocating the Common Benefit Fees provided for in the Settlement; and
  - e. Be guided in their work by the Orders of the Court related to Fees and Costs.
5. The Fee Panel shall develop procedures for receiving a single application, which may be updated or amended based on new information (such as participation by additional Litigating Subdivisions) from each Applicant seeking compensation from each sub fund of the Attorney Fee Fund pursuant to processes and procedures developed by the Fee Panel, which shall not be inconsistent with this Fee Agreement. Any request for attorneys' fees not included on the single application or through the updating/amendment process designed by the Fee Panel shall be deemed waived. For purposes of transparency and to permit the Fee Panel to conduct its work, the application from each Applicant shall, at a minimum, require each Applicant to:
- a. Identify all Litigating Subdivisions for which s/he is seeking payment from the Attorney Fee Fund;
  - b. Identify all Subdivisions in both Settling and Non-Settling States (and, where applicable, Tribal Nations) with respect to which s/he has a Fee Entitlement with respect to Relevant Claims against Released Entities, and identify all co-counsel in such cases;
  - c. Identify which of those Subdivisions are Participating Subdivisions and which are not (with similar information for Tribal Nations, where applicable);
  - d. Specify the specific fund or funds within the Attorney Fee Fund from which the Attorney is seeking compensation;
  - e. Demonstrate his or her eligibility for compensation from the relevant sub funds within the Attorney Fee Fund pursuant to the criteria set forth for the relevant sub fund;

- f. Identify any and all Fee Entitlements from representations of States, Tribal Nations, or other plaintiffs related to Released Claims against Released Entities or in opioids-related matters;
  - g. Notwithstanding “a-f” above, the Panel may consider a supplemental application if the Applicant shows good cause why circumstances exist that will lead to consideration for additional Common Benefit award. Examples would include, but are not limited to, an Applicant having Non-Participating Litigating Subdivision clients that subsequently become Participating Subdivisions, a Bar Date passes that increases participation or an Allocation Agreement is reached.
6. With respect to the Common Benefit Fund, the Fee Panel shall (subject to any applicable MDL Court Order):
- a. Review the applications of all Applicants seeking compensation from the Common Benefit Fund, including determining eligibility for each Applicant as set forth in Section II.G.
  - b. Using criteria set forth in Sections II.C and II.G, allocate amounts from the Common Benefit Fund to eligible Applicants, including payment amounts for each Payment Year. In making such allocations, the Panel shall apply the principles set forth in paragraph II.C.5 to the amounts paid to Applicants with a Common Benefit Fee Entitlement.
7. With respect to the Contingency Fee Fund, the Fee Panel shall:
- a. Review the applications of all Attorneys seeking compensation from the Litigating Subdivision Fee Fund, including determining eligibility for each Attorney as set forth in Section II.G.
  - b. Apply the Mathematical Model in Exhibit A.
  - c. Use such allocations to determine refund amounts owed to Walmart from the Attorney Fee Fund, and inform Walmart and the MDL PEC of all such adjustments.
8. To the extent that there is a dispute about the calculations of the Fee Panel related to the amount that Walmart is required to pay (including application of any reductions or refunds under this Fee Agreement), such disputes shall be presented to the Fee Panel and any disputed funds be paid into/held in escrow. The Fee Panel shall resolve such disputes expeditiously, with either Party having the right to seek review from the MDL Court.
9. For purposes of determination of fee or cost awards, allocations, reductions, and possible reversions under this Fee Agreement, unless specified otherwise

a Subdivision will be considered a Non-Participating Subdivision if it is not a Participating Subdivision as of the deadline for the application for the fee at issue (or, if the determination does not involve a specific application, the date on which the record for such determination closes).

10. In the event that the Fee Panel, through the use of the Mathematical Model set forth in Exhibit A, allocates funds from the Contingency Fee Fund for an Attorney based on a Qualifying Representation of a Participating Litigating Subdivision and that Subdivision is in a Settling State in which the Consent Judgment has not been approved, such funds shall be placed into escrow until the Consent Judgment is approved, after which time they shall be released.

*I. Miscellaneous.*

1. The Fee Panel shall charge an hourly rate approved by the Court. The Pre-Effective Date costs associated with the Cost and Expense Fund Administrator shall be paid from funds in the Cost Fund. Post-Effective Date, the cost of the Fee Panel shall be charged against the applicable Fee Fund based on allocation by the Fee Panel and shall not be otherwise funded by Walmart.
2. The MDL PEC will seek, and the Attorneys General for Settling States and the Walmart will not oppose, a Common Benefit Fee Order requiring an assessment of 7.5% on the gross recovery (by judgment or settlement) of any Non-Participating Subdivision that is subject to the federal court jurisdiction, represented by a MDL PEC firm, represented by any Attorney receiving fees from the Common Benefit Fund, represented by any Attorney that signed a Participation Agreement or had been paid in a case otherwise under the jurisdiction of the MDL Court.
3. The MDL PEC shall provide to Walmart information the PEC has that identifies Attorneys who represent Litigating Subdivisions who are not Participating Subdivisions and who have an obligation to pay a common benefit assessment, either due to the MDL Court's orders or having signed a Participation Agreement.
4. The MDL PEC and Walmart agree that it is a conflict of interest for an Attorney that had represented a Participating Subdivision to represent a Later Litigating Subdivision or Later Litigating State. This Subsection shall be enforceable to the extent permitted by the equivalent to Rules 1.16 and 5.6 of the ABA Model Rules of Professional Conduct in the relevant jurisdictions. The MDL PEC represents that it will comply with this provision in the case of the Walmart Agreement until the Effective Date of the Walmart Agreement, as well as thereafter, if the Walmart Agreement proceeds.
5. Participating Subdivisions agree to instruct their counsel to treat information, work product and expert materials as confidential under Rule 1.6 of the ABA Model Rules of Professional Conduct. Accordingly, an Attorney shall not

share information or work product with, or experts or materials to, non-participants (other than the Attorney's own current clients or their lawyers, consultants, experts or other representatives or agents). However, nothing herein shall prevent MDL Leadership or PEC Counsel from fulfilling their obligations in any MDL and the MDL Court Order.

### III. Miscellaneous

- A. *Termination.* If the Walmart Agreement does not proceed past the date on which the Settlement Fund Administrator makes a determination as to whether the Subdivision Participation Thresholds have been satisfied and the time for the Parties to the Walmart Agreement to dispute such determination has passed, this Fee Agreement shall be null and void, Walmart shall have no obligation to make any payments under this Fee Agreement, and Walmart and the MDL PEC shall take such steps as are necessary to restore the *status quo ante*. All funds paid by Walmart into the Attorney Fee Fund and Cost Fund shall be promptly returned to Walmart (including interest that accrues during such time as the monies are in escrow).
- B. *MDL Court Consideration.* This Fee Agreement shall be attached as an exhibit to the Walmart Agreement. This Fee Agreement shall also be submitted by Walmart and the MDL PEC to the MDL Court for approval pursuant to the motion and order that shall be attached, prior to the notice date under Section II.A.3 of the Walmart Agreement as to whether the State Participation Threshold has been satisfied, to this Fee Agreement, as Exhibit B.
1. In the event that the MDL Court, through an order, makes any change to the amounts potentially to be paid by Walmart under this Fee Agreement, makes any change to the Fee Panel's consideration of the factors set forth in paragraph II.C.4, or any other material change to the draft Order attached as part of Exhibit B or the terms of this Fee Agreement, Walmart and the MDL PEC shall meet and confer concerning such changes. The MDL Court shall have no authority to increase the payments made by Walmart related to fees and costs beyond the amounts described in this Fee Agreement.
  2. If Walmart and the MDL PEC are unable to reach agreement and revisions to this Fee Agreement, this Fee Agreement shall be null and void, Walmart shall have no obligation to make any payments under this Fee Agreement, and Walmart and the MDL PEC shall take such steps as are necessary to restore the *status quo ante*. All funds paid by Walmart into the Attorney Fee Fund and Cost Fund shall be promptly returned to Walmart (including interest that accrues during such time as the monies are in escrow prior to the Effective Date of the Walmart Agreement).

- C. *Amendment.* Once the MDL Court has entered an order implementing this Fee Agreement, this Fee Agreement can only be amended by (1) written agreement of Walmart and the MDL PEC and (2) approval by the MDL Court.
- D. *Jurisdiction and Enforcement.* The MDL Court shall have exclusive and ongoing jurisdiction over the enforcement and implementation of this Fee Agreement as set forth herein. The MDL PEC shall be the Authorized Party to enforce this Fee Agreement, as to the payment obligations of Walmart as set forth in this Fee Agreement and as to Attorneys making application to the Funds under this Fee Agreement. Solely for purposes of assessing or allocating common benefit fees, the MDL Court will continue to have jurisdiction over the work product developed in the MDL Court by and under the direction of the MDL PEC with respect to claims against Walmart, including data and documents, depositions, expert reports, briefs and pleadings; and the MDL Court's protective orders, management orders, and other decisions regarding such discovery and other work product, including but not limited to, conditions on its use, will continue in full force and effect. Nothing in this paragraph authorizes the MDL Court to act contrary to this Agreement or to share any of the work product, or provides the MDL Court with jurisdiction over the Walmart Agreement.

## Description of Mathematical Model for the Allocation of the Contingency Fee Funds

### Walmart Settlement Agreement

This document describes the Mathematical Model for allocation of the Contingency Fee Fund described in Exhibit R (Agreement of Attorneys' Fees, Costs, and Expenses) to the Walmart Settlement Agreement.<sup>3</sup> Awards of fees from the Contingency Fee Funds shall be available to Attorneys with Qualifying Representations of Participating Litigating Subdivisions eligible to receive an allocation under the Walmart Settlement Agreement.<sup>4</sup> A Fee Panel shall oversee the application of the Model and resolve any questions or disputes concerning the eligibility of a counsel to participate. The Panel is empowered to hear disputes concerning and ensure the accuracy of the mathematical calculations.

In general terms, allocation of the Contingency Fee Fund shall be made by (1) determining the amount of the Settlement Fund that is attributable to each Participating Litigating Subdivision; (2) making certain adjustments to these amounts based on when the Subdivision filed suit and the terms of the applicable fee contract; and (3) dividing the Contingency Fee Fund proportionately among counsel for each Participating Litigating Subdivision based on the amounts calculated in subpart 2.

To collect a fee award from the Contingency Fee Fund, a Participating Litigating Subdivision must have named Walmart in its lawsuit. The total maximum amount of the Contingency Fee Fund in the Walmart Settlement Agreement is \$107,088,150.77.<sup>5</sup>

Allocation of the Contingency Fee Fund shall be made according to the following steps. These calculations are made only for purpose of determining the percentage share of the Contingency Fee Fund that Attorneys for each Participating Litigating Subdivision should receive, *not* for determining the dollar amount each Subdivision will receive.

(1) For each Settling State, attribute 50% of the settlement funds for that State to its Subdivisions according to the Subdivision Allocation Percentage in Exhibit G to the Walmart Settlement Agreement.

Illustrative example:

- Assume that State A is allocated 1.00000% of the \$2,393,794,118.64 Remediation amount [see Exhibit M of the Walmart Settlement Agreement].
- 50% of the 1% share allocated to State A is \$11,968,970.60.
- Assume that, per Exhibit G of the Agreement, the

---

<sup>3</sup> See Walmart Settlement Agreement, Exhibit R § II.D.2.

<sup>4</sup> Walmart Settlement Agreement, Exhibit R § II.D.2.

<sup>5</sup> Walmart Settlement Agreement, Exhibit R § II.A.1 & II.D.1.

Subdivision Allocation Percentage for City B in State A is 1.00000000%.

- For purposes of determining its counsel's share of the Contingency Fee Fund, City B is attributed 1.00000000% of \$11,968,970.60, or \$119,689.71.

(1) Adjust the amounts in paragraph 1 as follows:

- a. *Upward Adjustment for Early Filers.* Increase the amount calculated in paragraph 1 above by 10% for any Litigating Subdivision that named Walmart in a suit before December 5, 2017, the date the National Prescription Opiate Litigation MDL was formed. If the Litigating Subdivision did not name Walmart in a suit before December 2, 2022, then fees from the Contingency Fee Fund will not be awarded to Attorneys with otherwise Qualifying Representations of that Participating Litigating Subdivision.

Illustrative Example:

- Assume City C is attributed \$1,000,000 under paragraph 1 above.
- If City C named Walmart before 12/5/2017, the attributed amount would be adjusted to \$1,100,000.

- b. *Determine Amount Due under Contingency Fee Contract.* Determine the amount that would be due to Attorneys with Qualifying Representations of each Participating Litigating Subdivision under the terms of the applicable fee contract if the Participating Litigating Subdivision were to receive the amount calculated in paragraph 2.a. This amount can be referred to as the Contingency Fee Assumption.

Illustrative Example:

- Continuing the example given in paragraph 2.a, if Attorneys have a 20% contingency fee contract with City C for the relevant litigation, the amount calculated in this step would be 20% of \$1,100,000, or \$220,000.

In the next step, the Contingency Fee Assumption is used to determine the percentage share of the Contingency Fee Fund due to Attorneys for each Participating Litigating Subdivision.

(2) Divide the Contingency Fee Fund proportionately among Attorneys for each Participating Litigating Subdivision in two ways:

- a. *National Fee Pool Calculation.* Determine each Litigating Subdivision's percentage share of all amounts due under contingency fee contracts nationwide



by dividing the Contingency Fee Assumption calculated for each Subdivision in paragraph 2.b by the sum of all Contingency Fee Assumptions. Then multiply that percentage by the Contingency Fee Fund to figure each Subdivision's dollar share of the Contingency Fee Fund (but only if the Subdivision timely named Walmart in a lawsuit).

Illustrative example:

- $\$220,000$  [from para. 2.b]  $\div$   $\$1,800,000,000$  [total amount owed under contingency fee contracts nationwide] =  $0.012222\%$ <sup>6</sup>
- $0.012222\% * \$107,088,150.77$  [Contingency Fee Fund] =  $\$13,088.31$

- b. *Separate State Fee Pools Calculation.* Determine each Litigating Subdivision's percentage share of all amounts due under contingency fee contracts statewide by dividing the Contingency Fee Assumption calculated for each Subdivision in paragraph 2.b by the sum of all Contingency Fee Assumptions in the same State. Then multiply that percentage by the portion of the Contingency Fee Fund that corresponds to that State's Overall Allocation Percentage, shown in Exhibit F of the Walmart Settlement Agreement, to figure each Subdivision's dollar share of the Contingency Fee Fund (but only if the Subdivision timely named Walmart in a lawsuit).

Illustrative example:

- $1\% * \$107,088,150.77 = \$1,070,881.51$  [amount of the Contingency Fee Fund corresponding to State A]
- Assume a total of  $\$17,600,000$  is owed under contingency fee contracts for State A.
- $\$220,000$  [from para. 2.b]  $\div$   $\$17,600,000 = 1.25\%$
- $1.25\% * \$1,070,881.51 = \$13,386.02$

The award of fees to Attorneys with Qualifying Representations of Participating Litigating Subdivisions will be the average of the final amounts calculated in paragraphs 3.a and 3.b above.<sup>7</sup>

---

<sup>6</sup> In this example, \$1.8 billion is the amount theoretically owed under all contingency fee contracts for litigation against Walmart as calculated in paragraph 2.b. This amount is illustrative only; the actual amount will not be known until all Participating Litigating Subdivisions are identified and the terms of all of their contingency fee contracts are collected.

<sup>7</sup> The model also enforces a maximum fee award of 20% of the amount calculated in paragraph 2.b. This rule is designed to prevent windfalls by addressing over-allocation in a small number of states with relatively few Participating Litigating Subdivisions. An estimated 97% of Qualifying Representations are not impacted this rule. The description in this document of the Mathematical Model is by necessity an abstraction; the precise contours of the calculations are defined in the model itself.

Paragraph 3.a represents allocation based on a proportional share of a National Fee Pool, while paragraph 3.b represents allocation based on a proportional share of the Separate State Fee Pools. In other words, for the National Fee Pool described above in paragraph 3.a, the contingency fee contract rate is compared to all other contingency fee contract rates in the nation. For the Separate State Fee Pools described above in paragraph 3.b, the contingency fee contract terms are compared to the other contingency fee contract terms in that same State. The National Fee Pool and the Separate State Fee Pools are given equal weighting.

Using the first methodology, Attorneys for two Subdivisions in different States with the same amount calculated under paragraph 2.b would be assigned the same amount under paragraph 3.a. Using the second methodology, Attorneys for the same two Subdivisions would be assigned different amounts under paragraph 3.b because they are in different States. Specifically, the Subdivision in the State with a smaller proportion of Participating Litigating Subdivisions would be allocated more than the Subdivision in the State with a greater proportion of Participating Litigating Subdivisions.

By: \_\_\_\_\_

Name: Rachel Brand  
Executive Vice President of Global  
Governance, Chief Legal Officer and  
Corporate Secretary

Date: \_\_\_\_\_

*On behalf of Walmart Inc.*

By: \_\_\_\_\_

Name: Paul T. Farrell, Jr.

Date: \_\_\_\_\_

By: \_\_\_\_\_

Name: Jayne Conroy

Date: \_\_\_\_\_

By: \_\_\_\_\_

Name: Joseph F. Rice

Date: \_\_\_\_\_

*On behalf of Plaintiffs' Executive Committee*

## EXHIBIT S

### Agreement on the State Outside Counsel Fee Fund for Chain Pharmacy Settlements

1. **Definitions.**

- a. “Chain Pharmacy” means any of CVS, Walgreens, and Walmart, and “Chain Pharmacies” means all of the foregoing.
- b. “Multistate Chain Pharmacy Settlement Agreement” means This Settlement Agreement along with any other settlement of opioids-related claims among 30 or more states and a Chain Pharmacy.
- c. “This Settlement Agreement” means the settlement agreement between the Settling States and the Chain Pharmacy to which this Agreement is attached as an Exhibit.
- d. “Settling Chain Pharmacy” means the Chain Pharmacy that is a party to This Settlement Agreement.
- e. “Settling States” has the meaning given such term in the relevant Multistate Chain Pharmacy Settlement Agreement.

2. **Creation of a State Outside Counsel Chain Pharmacies Fee Fund.** The Settling States have agreed to the creation of a state outside counsel fee fund to pay reasonable attorneys’ fees of Settling States which have retained outside counsel in connection with litigation against one or more Chain Pharmacies (such fund, the “State Outside Counsel Chain Pharmacies Fee Fund”).

3. **State Outside Counsel Chain Pharmacies Fee Fund Administration.** The State Outside Counsel Chain Pharmacies Fee Fund shall be administered separately from any other funds for the payment of attorneys fees or costs in connection with This Settlement Agreement, including any common benefit fund, contingency fee fund for subdivision counsel, state cost fund, or MDL expense fund. If necessary, a committee of Attorneys General shall be convened to oversee the State Outside Counsel Chain Pharmacies Fee Fund (the “Chain Pharmacies Fee Fund Committee”). The Chain Pharmacies Fee Fund Committee shall be appointed by the Settling State Members of the Enforcement Committee and shall be comprised solely of Attorneys General of Settling States that engaged outside counsel to pursue litigation against one or more Chain Pharmacies. The Settlement Fund Administrator (the “Fee Fund Administrator”) shall administer the State Outside Counsel Chain Pharmacies Fee Fund according to this Exhibit and, if convened, the guidelines and directives of the Chain Pharmacies Fee Fund Committee.

4. **State Outside Counsel Chain Pharmacies Fee Eligibility.**

- a. To receive any amount from the State Outside Counsel Chain Pharmacies

Fee Fund, an outside counsel to a Settling State must have filed and maintained an action in the name of a Settling State or its Attorney General against a Chain Pharmacy in a state or federal court as of November 1, 2022. No Settling State (or its outside counsel) shall receive funds from both the State Outside Counsel Chain Pharmacies Fee Fund and any “Additional Remediation Amount” as may be provided for in This Settlement Agreement.

- b. In addition to the eligibility criteria set forth in Paragraph 4.a, above, and for the avoidance of doubt, only Settling States under This Settlement Agreement are eligible to receive any funds paid into the State Outside Counsel Chain Pharmacies Fee Fund as a result of This Settlement Agreement.

5. **State Outside Counsel Chain Pharmacies Fee Fund Amount.** The Settling Chain Pharmacy shall pay funds into the State Outside Counsel Chain Pharmacies Fee Fund in an amount equal to, and on the schedule identified in Exhibit M (the “Contribution”). The Settling Chain Pharmacy’s Contribution shall subject to a reduction as described in Paragraph 8, below.

6. **State Outside Counsel Chain Pharmacies Fee Fund Availability and Calculation of Amount.**

- a. The State Outside Counsel Chain Pharmacies Fee Fund shall be available to compensate private outside counsel for Settling State Attorneys General for approved fees arising out of representation of the Settling State pursuant to the schedule attached to this agreement as Schedule I (the “Fee Schedule”).
- b. The Fee Schedule is intended to reflect the fee calculation in subparagraph 6.c, below (the “Fee Calculation”). Subject to adjustments required by Paragraph 8, below, in the event of any discrepancy between the Fee Schedule and the Fee Calculation, the Fee Schedule shall control. Each Settling State, by becoming a Participating State in This Settlement Agreement, agrees that the Fee Schedule reflects the Fee Calculation and waives any right to contest the accuracy of the Fee Schedule, absent manifest error, the exclusion of a Settling State, or the inclusion of a Non-Settling State. The version of the Fee Schedule reflecting any necessary adjustments shall be the “Final Fee Schedule.”
- c. Fees shall be aggregated across the Multistate Chain Pharmacy Settlement Agreements and be calculated by adding two components: (a) a fixed amount consisting of fifty percent (50%) of the amount of remediation funds allocated to a Settling State and its Subdivisions pursuant to the Multistate Chain Pharmacy Settlement Agreements multiplied by 4.5%; and (b) a proportional percentage of the remaining fee due under that

Settling State's contract with its outside counsel assuming that fifty percent (50%) of the Settling State's recovery is allocable to a Settling State (rather than allocable to the Settling State's Participating Subdivisions) so that the fees of all eligible Settling States (minus the fixed amount that would have been allocated to any Non-Settling States had they become Settling States) exhausts the State Outside Counsel Chain Pharmacies Fee Fund. The proportional share percentage will be the same for each Settling State included in the State Outside Counsel Chain Pharmacies Fee Fund. Fees shall be split proportionally among each Multistate Chain Pharmacy Settlement Agreement, as set forth on the Fee Schedule.

- d. All amounts paid will be less any costs or fees of the Fee Fund Administrator. The Fee Schedule reflects a holdback amount of \$50,000 for such administrative expenses of the Fee Fund Administrator. The remainder of any unused administrative expenses shall be disbursed pro rata to States receiving monies from the State Outside Counsel Chain Pharmacies Fee Fund at the conclusion of such administration.

**7. Payment by the Fee Fund Administrator.**

- a. The Fee Fund Administrator shall hold the Contribution in escrow until the earlier of (1) the last of the three Multistate Chain Pharmacy Settlement Agreements becomes effective or (2) when instructed by the Settling State Members of the Enforcement Committee.
- b. Subject to eligibility pursuant to Paragraph 4, above, a Settling State's outside counsel may receive funds from the State Outside Counsel Chain Pharmacies Fee Fund in the following scenarios ("Payment Scenarios"):
  1. The Settling State's outside counsel agrees that the amount listed for such state on the Final Fee Schedule either satisfies in full or exceeds the amounts owed to all such Settling State's outside counsel and such counsel has provided written notice waiving all entitlement to additional fee in respect of any Multistate Chain Pharmacy Settlement Agreement.
  2. The Settling State and its outside counsel enter into a signed writing establishing the amount owed to the counsel, which includes an agreement on the payment of the amount listed for such state on the Final Fee Schedule and waives any right of the State or its outside counsel to additional amounts from the State Outside Counsel Chain Pharmacies Fee Fund.
  3. A final judgment is entered that is no longer appealable, which judgement adjudicates the amount owed to the Settling State's counsel in respect of This Settlement Agreement and directs the Chain Pharmacies Fee Fund Committee how to pay the amount listed on the Final Fee Schedule for such State.

If no Payment Scenario is applicable with respect to a Settling State, then

the Settling State's share shall be placed in an interest-bearing escrow account (less reasonable expenses of the Fee Fund Administrator) and held unless and until a Payment Scenario is applicable.

- c. Upon the applicability of a Payment Scenario 1 with respect to a Settling State, the Fee Fund Administrator shall pay that Settling State's outside counsel the amount identified on the Final Fee Schedule for such state or such lesser amount that satisfies the Settling State's obligation to its outside counsel in full. Any remaining allocation to such State shall be paid to the Settling State.
- d. Upon the applicability of a Payment Scenario 2 or 3 with respect to a Settling State, the Fee Fund Administrator shall release monies from the State Outside Counsel Chain Pharmacies Fee Fund in either the amount held by the Fee Fund Administrator, if the amount of the agreement or judgment is equal to or more than the amount held, or the amount indicated in the agreement or in the final judgment, if the amount in the agreement or judgment is less than the amount held.
- e. Nothing herein, including the amounts listed in Paragraph 6 above or on any Fee Schedule, shall prevent a Settling State from arguing in any proceeding with its outside counsel that (i) its recovery was less than fifty percent (50%) of the recovery in the settlement agreement down to and including fifteen percent (15%) of the total recovery; (ii) any payment should be discounted by an appropriate discount rate commensurate to the risk of the settlement agreement and the timeline that the Settling State is receiving its payments; (iii) the settlement amount should be lower because the amount a Settling State receives was reduced because such Settling State's outside counsel failed to obtain joinder from a Settling State's Subdivision(s) that the outside counsel also represented; or (iv) any limitation placed by the Settling Chain Pharmacy bars payment of a higher fee to outside counsel.
- f. In the event the amount due to the Settling State's outside counsel from an escrow account is less than the total amount of funds escrowed on the account of the Settling State, the balance shall be paid to the Settling State. In no event, other than a State becoming a Non-Settling State, shall funds revert to a Chain Pharmacy.

8. **Reduction of Amounts Owed**

- a. **Non-Settling States; Reversion and Redistribution.** Amounts owed by the Settling Chain Pharmacy to the State Outside Counsel Chain Pharmacies Fee Fund shall be reduced by amounts allocated to the fixed amount for such State under This Settlement Agreement in the event that a listed State becomes a Non-Settling State. Specifically, the reduction in the amount owed by the Settling Chain Pharmacy shall be calculated as 2.25% times the total Remediation Payments that would have been allocated to the



Non-Settling State had it been a Settling State. The payments for the other Settling States reflected in the Fee Schedule shall be adjusted by the Fee Fund Administrator to reflect a recalculated proportional percentage under the Fee Calculation.

- b. **Settling States; Redistribution.** If a Settling State under This Settlement Agreement (i) would otherwise be entitled to a payment from the State Outside Counsel Chain Pharmacies Fee Fund and (ii) is eligible to be a “Settling State” under either of the two other Multistate Chain Pharmacy Settlement Agreements but does not become such a “Settling State,” then that Settling State’s payment from the State Outside Counsel Chain Pharmacies Fee Fund shall be reduced to an amount equal to the Contribution times the Settling State’s allocation percentage on Exhibit F, which shall be treated as an additional remediation payment in lieu of a fee payment. The payments for the other Settling States reflected in the Fee Schedule shall be adjusted by the Fee Fund Administrator to reflect a recalculated proportional percentage under the Fee Calculation.
- c. If either or both of the other Chain Pharmacies fail to enter into a Multistate Chain Pharmacy Settlement Agreement, or if such Multistate Chain Pharmacy Settlement Agreements fail to take effect by December 15, 2023, then the Settling Chain Pharmacy and the Enforcement Committee shall renegotiate the terms of Paragraph 8.a in order to permit prompt payment to Settling States that terminated contested litigation with the Settling Chain Pharmacy, and permitting additional time if necessary to finalize payments to the other Settling States. In no event will such renegotiation result in additional reversion of monies in the State Outside Counsel Chain Pharmacies Fee Fund to the Settling Chain Pharmacy.

9. **Interpretation.**

- a. This Agreement shall be an Exhibit to each Multistate Chain Pharmacy Settlement Agreement and shall include the Fee Schedule setting forth the presumptive payment calculations for each eligible Settling State. By joining This Settlement Agreement, each State agrees on the presumptive accuracy of the Fee Schedule, absent manifest error, the inclusion of a Non-Settling State, or the exclusion of a Settling State.
- b. It is the intent of all parties that the State Outside Counsel Chain Pharmacies Fee Fund function in a similar manner, with similar calculations and mechanics, as the “State Outside Counsel Fee Fund” established in Exhibit S of that certain settlement agreement dated as of July 21, 2021 setting forth the terms of settlement between and among McKesson Corporation, Cardinal Health, Inc., and AmerisourceBergen Corporation, on the one hand, and certain settling states and certain participating subdivisions, on the other hand.

**Schedule I to Exhibit S**

**Fee Schedule**

[This Fee Schedule will require adjustment to reflect final settlement amounts and allocations in Walgreens and CVS, but the highlighted “total” under “Walmart Total Fee” should be final absent exclusion of non-settling states.]

State	Total Fee	Walgreens Share	Walmart Share	CVS Share
Alaska	\$1,796,822.89	\$676,324.48	\$402,729.18	\$717,769.22
Arkansas	\$4,767,283.93	\$1,794,406.60	\$1,068,510.62	\$1,904,366.71
Delaware	\$3,613,736.46	\$1,360,211.11	\$809,961.37	\$1,443,563.99
Kentucky	\$7,662,831.34	\$2,884,291.20	\$1,717,501.38	\$3,061,038.76
Michigan	\$21,581,881.97	\$8,123,424.56	\$4,837,234.48	\$8,621,222.92
Mississippi	\$4,537,607.39	\$1,707,956.30	\$1,017,032.29	\$1,812,618.79
Nevada	\$9,091,169.76	\$3,421,918.06	\$2,037,640.64	\$3,631,611.06
New Hampshire	\$5,788,801.66	\$2,178,906.07	\$1,297,467.52	\$2,312,428.06
New Mexico	\$2,681,454.30	\$2,681,454.30	\$-	\$-
Puerto Rico	\$6,672,535.07	\$2,511,543.49	\$1,495,542.27	\$2,665,449.30
South Dakota	\$1,075,884.59	\$404,963.17	\$241,142.36	\$429,779.06
Utah	\$4,779,469.83	\$1,798,993.37	\$1,071,241.90	\$1,909,234.56
West Virginia	\$2,355,834.67	\$2,355,834.67	\$-	\$-
	<b>Admin Expense Holdback</b>	\$20,875.66	\$10,467.86	\$18,656.48
	<b>Total</b>	\$31,921,105.05	<b>\$16,006,471.88</b>	\$28,527,738.91

Excluded States:

- Florida (Walgreens; Walmart; CVS)
- New Mexico (Walmart; CVS)
- West Virginia (Walmart; CVS)

## EXHIBIT T

### Agreement on the Joint State Cost Fund

1. **Definitions.**

- a. “Opioids Defendant” means Walmart, or such other defendant in opioids-related litigation that enters into a Multistate Settlement after November 1, 2022, and “Opioids Defendants” means all of the foregoing.
- b. “Multistate Settlement” means this Settlement Agreement along with any other settlement of opioids-related claims among 30 or more states and an Opioids Defendant.
- c. “Settlement Agreement” means the settlement agreement between the Settling States and the Opioids Defendant to which this Agreement is attached as an Exhibit.
- d. “Settling Opioids Defendant” means the Opioids Defendant that is a party to the Settlement Agreement.
- e. “Settling States” has the meaning given such term in the Settlement Agreement.

2. **Creation of a State Cost Fund.** The Settling Opioids Defendant and the Settling States agree to the creation of a fund to pay costs and expenses associated with litigation and investigations related to the opioids litigation (such fund, the “State Cost Fund”). The State Cost Fund shall be administered separately from any other funds for the payment of attorneys fees or costs in connection with the Settlement Agreement, including any common benefit fund, contingency fee fund for subdivision counsel, subdivision cost fund, or MDL expense fund. However, the State Cost Fund shall be administered jointly with similar “State Cost Funds” created in other Multistate Settlements after November 1, 2022; any state cost funds jointly administered in this manner shall be referred to as the “Joint State Cost Fund.” To the extent permissible and feasible, the Joint State Cost Fund may also be jointly administered with any fund for reimbursement of states’ litigation and investigation costs established by a bankruptcy plan, including the Mallinckrodt bankruptcy plan, any plans that may emerge from the bankruptcies of Purdue and Endo, and any similar bankruptcies of opioids defendants. To the extent feasible, the Joint State Cost Fund may also be jointly administered with the State Cost Funds established pursuant to the Distributors Multistate Settlement and the Janssen Multistate Settlement.

3. **State Cost Fund Amount.** The Settling Opioids Defendant shall pay into the State Cost Fund in the amount listed on, and on the schedule set forth in, Exhibit M (the “Settling Opioids Defendant’s Contribution”) for the purpose paying States’ costs and

expenses associated with to the opioid litigation.

4. **Joint State Cost Fund Committee.** A committee of Attorneys General or their designated representatives (such committee, the “Joint State Cost Fund Committee”) shall oversee the Joint State Cost Fund. The committee shall be appointed by the Settling State Members of the Enforcement Committee, who shall aim to (i) have equal representation between states that retained contingency fee outside counsel and states that did not retain contingency fee outside counsel with respect to opioids-related litigation, and (ii) maintain consistency of committee membership across state cost funds that compose the Joint State Cost Fund. The Settling State Members of the Enforcement Committee may by majority vote add to or change the composition of the Joint State Cost Fund Committee.

5. **Joint State Cost Fund Administrator.**

- a. The Joint State Cost Fund Committee may select an administrator (the “Joint State Cost Fund Administrator”), who shall administer the Joint State Cost Fund and direct payments to Settling States according to the guidelines and directives of the Joint State Cost Fund Committee. While the expenses of the Joint State Cost Fund Administrator shall be reimbursable pursuant to the principles and guidelines listed below, the Joint State Cost Fund Administrator shall first rely on any separate funds that may be set aside for such purpose in any Multistate Settlement.
- b. The Joint State Cost Fund Administrator shall be responsible, under the direction and supervision of the Joint State Cost Fund Committee, for receiving and reviewing applications for reimbursement from the Joint State Cost Fund. This may include the creation of an audit process to ensure the integrity of submissions, as well as reimbursement rules to incentivize accurate submissions.

6. **State Cost Fund Guidelines and Principles.**

- a. Monies in the State Cost Fund shall be released without any delay to reimburse Settling States for documented costs incurred or paid in connection with litigation and investigation related to the opioid litigation.
- b. In allocating the Joint State Cost Fund, the Joint State Cost Fund Committee shall seek to comply with the following principles:
  1. Each State Cost Fund should be used to reimburse costs incurred by States that are Settling States in the Multistate Settlement from which funds are paid. (However, the foregoing sentence does not preclude a Non-Settling State that joins a separate Multistate Settlement from participating in the Joint State Cost Fund with respect to contributions made by other Opioids Defendants.)

2. Funds in any State Cost Fund shall be primarily used to reimburse costs incurred prior to the date on which the relevant Multistate Settlement was first made available for participation to eligible States. Regardless of other factors considered in prioritizing payments, all costs incurred prior to January 1, 2023, shall be paid before any costs incurred after that date are paid.
3. The Joint State Cost Fund shall prioritize the reimbursement of the following over reimbursement of any State's litigation or investigation costs:
  - the reasonable costs of the Joint State Cost Fund Administrator;
  - repayment of National Association of Attorneys General grants made in connection with opioid litigation, without regard to when the grants were made;
  - repayment of state-attributable costs of any mediator in connection with negotiations of a Multistate Settlement;
4. The Joint State Cost Fund shall seek to prioritize costs in the following order:
  - litigation-related costs; then
  - investigation-related costs; then
  - settlement and negotiation related costs; then
  - cost shares.
5. Costs incurred by a State's outside counsel that the State is contractually obligated to reimburse shall be treated as costs incurred by a State.
6. As between similar categories of costs (e.g., defendant-specific litigation-related costs), the Joint State Cost Fund shall first reimburse costs incurred by a State's outside counsel that the State is contractually obligated to reimburse out of its recovery, and then reimburse costs directly incurred by States.
7. The Joint State Cost Fund shall be available to reimburse only those costs which have not yet been reimbursed to a State from any other source, including any other fund set aside in a Multistate

Settlement or bankruptcy plan for the reimbursement of costs or any individual state settlements.

8. The Joint State Cost Fund should not reimburse expenses that are expected to be reimbursed from another source, such as a bankruptcy debtor, unless such expected reimbursements do not come to fruition within a reasonable amount of time. This includes cost shares paid by states.
  9. When coordinating among different state cost funds that each could be used to reimburse a given expense, the Joint State Cost Fund Committee may set guidelines to equitably distribute reimbursements across all state cost funds in a manner that prioritizes costs unlikely to be otherwise reimbursed to a similarly situated State.
  10. The Joint State Cost Fund may deny reimbursement of costs, on either an individual basis or a categorical basis, that a supermajority (75%+) of the Joint State Cost Fund Committee determines to be unreasonable.
  11. After all costs identified in the foregoing have been reimbursed, the remaining funds in the Joint State Cost Fund shall be distributed to states in proportion to their allocation of remediation payments in the Mallinckrodt bankruptcy plan. Such distribution shall be treated as a reimbursement for States' unenumerated costs of administering the Multistate Settlements and no subdivision shares shall be carved out of such disbursement, nor shall any attorney's fees be assessed against such distribution (unless individually agreed to by a State).
- c. In applying the foregoing principles, the Joint State Cost Fund Committee shall have the discretion to vary their application in order to ensure equity among similarly situated states and to facilitate the ease and speed of administering the Joint State Cost Fund. The Joint State Cost Fund Committee may also apply percentages to approximate costs attributable to a particular Opioids Defendant (or categories of Opioids Defendants) in a manner that seeks to treat similarly situated states equitably.
  - d. The Joint State Cost Fund Committee shall establish guidelines for the submission and approval of expenses eligible for reimbursement from the Joint State Cost Fund, which guidelines may be coordinated and consolidated with any similar cost funds in other state opioid settlements for purposes of joint administration and efficiency.

- e. Unless waived by the Joint State Cost Fund Committee, the Joint State Cost Fund Administrator shall, in accordance with such guidelines, receive from Settling States records sufficient to demonstrate the incurrence and payment of each expense.
- f. Where the Joint State Cost Fund Committee determines by a supermajority vote (75%+) that outside counsel for a Settling State has failed to exercise reasonable diligence in reviewing submitted costs for allowability, and such failure has resulted in the reimbursement of unallowed costs to such outside counsel, the Committee shall have the discretion to reduce or recover payments made to such outside counsel in an amount calculated to incentivize the exercise of reasonable diligence.

7. **State Undertakings.** Each State submitting for reimbursement of costs from the Joint State Cost Fund agrees:

- a. to only submit costs allowable under this Joint State Cost Fund Agreement;
- b. to provide all back-up documentation that may be requested with respect to any submitted cost and to make itself available for any questions related to such costs;
- c. to exercise reasonable diligence to ensure that all submitted costs are allowable under (i) this Joint State Cost Fund Agreement, (ii) the State's contract with its outside counsel, if relevant, (iii) state law, and (iv) the policies and procedures applicable to the State's retention of outside counsel, if relevant; and
- d. to promptly return any excess payments made to the State or its outside counsel from the Joint State Cost Fund, including payments made for costs that were reimbursed from another source or are not allowable hereunder.

**EXHIBIT U**  
**IRS Form 1098-F**

0303       VOID       CORRECTED

FILER'S name, street address, city or town, state or province, country, ZIP or foreign postal code, and telephone no.  [Appropriate Official] [Designated State] [Address]		1 Total amount required to be paid \$ *	OMB No. 1545-2284  Form <b>1098-F</b> (Rev. January 2022)	<b>Fines, Penalties, and Other Amounts</b>
FILER'S TIN XX-XXXXXXX		2 Amount to be paid for violation or potential violation \$ *	For calendar year 20 <u>22</u>	
PAYER'S TIN 71-0415188		3 Restitution/remediation amount \$ *	6 Date of order/agreement XX/XX/2022	<b>Copy A</b> <b>For Internal Revenue Service Center</b> <b>File with Form 1096.</b>  For Privacy Act and Paperwork Reduction Act Notice, see the current General Instructions for Certain Information Returns.
PAYER'S name Walmart Inc.		4 Compliance amount \$ *	7 Case number No. 1:17-md-2804, and other cases settled under the Settlement Agreement entered into by Walmart and the Settling States (as defined in such agreement), dated as of [ ]	
Street address (including apt. no.) 702 S. W. 8th Street		5 Court or entity U.S. District Court for the Northern District of Ohio and jurisdictions of other cases settled under the Settlement Agreement entered into by Walmart and the Settling States (as defined in such agreement), dated as of [ ]	8 Case name or names of parties to suit, order, or agreement National Prescription Opiate Litigation	
City or town, state or province, country, and ZIP or foreign postal code Bentonville, AR, USA 72716		9 Code A, B, I		

Form **1098-F** (Rev. 1-2022)      Cat. No. 71382B      www.irs.gov/Form1098F      Department of the Treasury - Internal Revenue Service

**Do Not Cut or Separate Forms on This Page — Do Not Cut or Separate Forms on This Page**

\*Amounts to be completed following confirmation of settlement participation.



**EXHIBIT V**

**WALMART SETTLEMENT AGREEMENT SIGN-ON FORM**

**This form indicates whether a State has determined to become a Settling State under the Walmart Settlement Agreement. Each Settling State’s Attorney General represents that he or she has or has obtained (or will obtain no later than the Threshold Subdivision Participation Date) the authority set forth in Section X.G. Attorneys General that determine to become a Settling State are committing to obtaining any necessary additional State releases prior to the Effective Date.**

The State/Commonwealth/Territory of \_\_\_\_\_ has determined:

- to become** or
- not to become**

a Settling State under the Walmart Settlement Agreement

\_\_\_\_\_  
Signature

\_\_\_\_\_  
Date

\_\_\_\_\_  
Printed Name

\_\_\_\_\_  
Title

**(1) Primary Contact for Your Office**

Name:

Title:

Email:

Direct Phone Number:

**(2) Secondary Contact for Your Office**

Name:

Title:

Email:

Direct Phone Number:

**(3) DEADLINE: THURSDAY, DECEMBER 15, 2022 AT 5:00 PM ET**

Please email your completed form to the following:

For Walmart:

Brian K. Mahanna  
Wilmer Cutler Pickering Hale and Dorr LLP  
7 World Trade Center  
250 Greenwich Street  
New York, NY 10007  
[Brian.Mahanna@wilmerhale.com](mailto:Brian.Mahanna@wilmerhale.com)

For the Attorneys General:

Josh Stein, Attorney General  
North Carolina Department of Justice  
Attn: Daniel Mosteller, Deputy General Counsel  
PO Box 629  
Raleigh, NC 27602  
Dmosteller@ncdoj.gov

**EXHIBIT W**

**Non-Litigating Threshold Subdivisions Exhibit**

- |                                     |  |
|-------------------------------------|--|
| 1. Alexander City, City of, Alabama | 42. Oxford, City of, Alabama                 |
| 2. Anniston, City of, Alabama       | 43. Pell City, City of, Alabama              |
| 3. Autauga, County of, Alabama      | 44. Prattville, City of, Alabama             |
| 4. Barbour, County of, Alabama      | 45. Russell, County of, Alabama              |
| 5. Blount, County of, Alabama       | 46. Russellville, City of, Alabama           |
| 6. Bullock, County of, Alabama      | 47. Shelby, County of, Alabama               |
| 7. Butler, County of, Alabama       | 48. St. Clair, County of, Alabama            |
| 8. Center Point, City of, Alabama   | 49. Sumter, County of, Alabama               |
| 9. Chambers, County of, Alabama     | 50. Talladega, City of, Alabama              |
| 10. Choctaw, County of, Alabama     | 51. Tuscaloosa, City of, Alabama             |
| 11. Clarke, County of, Alabama      | 52. Washington, County of, Alabama           |
| 12. Clay, County of, Alabama        | 53. Wilcox, County of, Alabama               |
| 13. Cleburne, County of, Alabama    | 54. Anchorage, Municipality of, Alaska       |
| 14. Colbert, County of, Alabama     | 55. Fairbanks, City of, Alaska               |
| 15. Conecuh, County of, Alabama     | 56. Fairbanks North Star, Borough of, Alaska |
| 16. Coosa, County of, Alabama       | 57. Juneau, City of/ Borough of, Alaska      |
| 17. Covington, County of, Alabama   | 58. Kenai Peninsula, Borough of, Alaska      |
| 18. Crenshaw, County of, Alabama    | 59. Matanuska-Susitna, Borough of, Alaska    |
| 19. Dale, County of, Alabama        | 60. Apache, County of, Arizona               |
| 20. DeKalb, County of, Alabama      | 61. Apache Junction, City of, Arizona        |
| 21. Dothan, City of, Alabama        | 62. Avondale, City of, Arizona               |
| 22. Escambia, County of, Alabama    | 63. Buckeye, City of, Arizona                |
| 23. Etowah, County of, Alabama      | 64. Bullhead City, City of, Arizona          |
| 24. Eufaula, City of, Alabama       | 65. Casa Grande, City of, Arizona            |
| 25. Fairfield, City of, Alabama     | 66. Chandler, City of, Arizona               |
| 26. Franklin, County of, Alabama    | 67. Cochise, County of, Arizona              |
| 27. Geneva, County of, Alabama      | 68. Coconino, County of, Arizona             |
| 28. Hale, County of, Alabama        | 69. El Mirage, City of, Arizona              |
| 29. Henry, County of, Alabama       | 70. Flagstaff, City of, Arizona              |
| 30. Hoover, City of, Alabama        | 71. Gila, County of, Arizona                 |
| 31. Houston, County of, Alabama     | 72. Gilbert, Town of, Arizona                |
| 32. Lee, County of, Alabama         | 73. Glendale, City of, Arizona               |
| 33. Leeds, City of, Alabama         | 74. Goodyear, City of, Arizona               |
| 34. Limestone, County of, Alabama   | 75. Graham, County of, Arizona               |
| 35. Lowndes, County of, Alabama     | 76. La Paz, County of, Arizona               |
| 36. Macon, County of, Alabama       | 77. Lake Havasu City, City of, Arizona       |
| 37. Madison, City of, Alabama       |  |
| 38. Monroe, County of, Alabama      |  |
| 39. Montgomery, City of, Alabama    |  |
| 40. Montgomery, County of, Alabama  |  |
| 41. Muscle Shoals, City of, Alabama |  |

78. Marana, Town of, Arizona
79. Maricopa, City of, Arizona
80. Mesa, City of, Arizona
81. Navajo, County of, Arizona
82. Oro Valley, Town of, Arizona
83. Peoria, City of, Arizona
84. Pima, County of, Arizona
85. Prescott Valley, Town of, Arizona
86. Queen Creek, Town of, Arizona
87. Sahuarita, Town of, Arizona
88. San Luis, City of, Arizona
89. Santa Cruz, County of, Arizona
90. Scottsdale, City of, Arizona
91. Sierra Vista, City of, Arizona
92. Surprise, City of, Arizona
93. Tempe, City of, Arizona
94. Tucson, City of, Arizona
95. Yavapai, County of, Arizona
96. Yuma, City of, Arizona
97. Arkadelphia, City of, Arkansas
98. Arkansas, County of, Arkansas
99. Ashley, County of, Arkansas
100. Batesville, City of, Arkansas
101. Baxter, County of, Arkansas
102. Bella Vista, City of, Arkansas
103. Benton, City of, Arkansas
104. Benton, County of, Arkansas
105. Bentonville, City of, Arkansas
106. Blytheville, City of, Arkansas
107. Boone, County of, Arkansas
108. Bradley, County of, Arkansas
109. Bryant, City of, Arkansas
110. Cabot, City of, Arkansas
111. Camden, City of, Arkansas
112. Carroll, County of, Arkansas
113. Centerton, City of, Arkansas
114. Chicot, County of, Arkansas
115. Clark, County of, Arkansas
116. Clay, County of, Arkansas
117. Cleburne, County of, Arkansas
118. Columbia, County of, Arkansas
119. Conway, City of, Arkansas
120. Conway, County of, Arkansas
121. Craighead, County of, Arkansas
122. Crawford, County of, Arkansas
123. Crittenden, County of, Arkansas
124. Cross, County of, Arkansas
125. Desha, County of, Arkansas
126. Drew, County of, Arkansas
127. El Dorado, City of, Arkansas
128. Faulkner, County of, Arkansas
129. Fayetteville, City of, Arkansas
130. Fort Smith, City of, Arkansas
131. Franklin, County of, Arkansas
132. Fulton, County of, Arkansas
133. Garland, County of, Arkansas
134. Grant, County of, Arkansas
135. Greene, County of, Arkansas
136. Harrison, City of, Arkansas
137. Hempstead, County of, Arkansas
138. Hot Spring, County of, Arkansas
139. Hot Springs, City of, Arkansas
140. Howard, County of, Arkansas
141. Independence, County of, Arkansas
142. Izard, County of, Arkansas
143. Jackson, County of, Arkansas
144. Jacksonville, City of, Arkansas
145. Johnson, County of, Arkansas
146. Jonesboro, City of, Arkansas
147. Lawrence, County of, Arkansas
148. Lincoln, County of, Arkansas
149. Little River, County of, Arkansas
150. Little Rock, City of, Arkansas
151. Logan, County of, Arkansas
152. Lonoke, County of, Arkansas
153. Madison, County of, Arkansas
154. Magnolia, City of, Arkansas
155. Malvern, City of, Arkansas
156. Marion, City of, Arkansas
157. Marion, County of, Arkansas
158. Maumelle, City of, Arkansas
159. Miller, County of, Arkansas
160. Mississippi, County of, Arkansas
161. Mountain Home, City of, Arkansas
162. North Little Rock, City of, Arkansas
163. Ouachita, County of, Arkansas
164. Paragould, City of, Arkansas
165. Perry, County of, Arkansas

166. Phillips, County of, Arkansas
167. Pike, County of, Arkansas
168. Pine Bluff, City of, Arkansas
169. Poinsett, County of, Arkansas
170. Polk, County of, Arkansas
171. Pope, County of, Arkansas
172. Randolph, County of, Arkansas
173. Rogers, City of, Arkansas
174. Russellville, City of, Arkansas
175. Saline, County of, Arkansas
176. Searcy, City of, Arkansas
177. Sebastian, County of, Arkansas
178. Sevier, County of, Arkansas
179. Sharp, County of, Arkansas
180. Sherwood, City of, Arkansas
181. Siloam Springs, City of,  
Arkansas
182. Springdale, City of, Arkansas
183. St. Francis, County of, Arkansas
184. Stone, County of, Arkansas
185. Texarkana, City of, Arkansas
186. Union, County of, Arkansas
187. Van Buren, City of, Arkansas
188. Van Buren, County of, Arkansas
189. Washington, County of,  
Arkansas
190. West Memphis, City of,  
Arkansas
191. White, County of, Arkansas
192. Yell, County of, Arkansas
193. Adelanto, City of, California
194. Alameda, City of, California
195. Alameda, County of, California
196. Alhambra, City of, California
197. Aliso Viejo, City of, California
198. Anaheim, City of, California
199. Antioch, City of, California
200. Apple Valley, Town of,  
California
201. Arcadia, City of, California
202. Atascadero, City of, California
203. Azusa, City of, California
204. Bakersfield, City of, California
205. Baldwin Park, City of, California
206. Banning, City of, California
207. Beaumont, City of, California
208. Bell, City of, California
209. Bell Gardens, City of, California
210. Bellflower, City of, California
211. Berkeley, City of, California
212. Beverly Hills, City of, California
213. Brea, City of, California
214. Brentwood, City of, California
215. Buena Park, City of, California
216. Burbank, City of, California
217. Burlingame, City of, California
218. Calexico, City of, California
219. Camarillo, City of, California
220. Campbell, City of, California
221. Carlsbad, City of, California
222. Carson, City of, California
223. Cathedral City, City of,  
California
224. Ceres, City of, California
225. Cerritos, City of, California
226. Chino, City of, California
227. Chino Hills, City of, California
228. Citrus Heights, City of,  
California
229. Claremont, City of, California
230. Clovis, City of, California
231. Coachella, City of, California
232. Colton, City of, California
233. Compton, City of, California
234. Concord, City of, California
235. Contra Costa, County of,  
California
236. Corona, City of, California
237. Costa Mesa, City of, California
238. Covina, City of, California
239. Culver City, City of, California
240. Cupertino, City of, California
241. Cypress, City of, California
242. Daly City, City of, California
243. Dana Point, City of, California
244. Danville, Town of, California
245. Davis, City of, California
246. Delano, City of, California
247. Diamond Bar, City of, California
248. Downey, City of, California
249. Dublin, City of, California
250. Eastvale, City of, California

251. El Cajon, City of, California
252. El Centro, City of, California
253. El Monte, City of, California
254. El Paso de Robles (Paso Robles),  
City of, California
255. Elk Grove, City of, California
256. Encinitas, City of, California
257. Escondido, City of, California
258. Eureka, City of, California
259. Fairfield, City of, California
260. Folsom, City of, California
261. Fontana, City of, California
262. Foster City, City of, California
263. Fountain Valley, City of,  
California
264. Fremont, City of, California
265. Fresno, City of, California
266. Fullerton, City of, California
267. Garden Grove, City of,  
California
268. Gardena, City of, California
269. Gilroy, City of, California
270. Glendale, City of, California
271. Glendora, City of, California
272. Glenn, County of, California
273. Goleta, City of, California
274. Hanford, City of, California
275. Hawthorne, City of, California
276. Hayward, City of, California
277. Hemet, City of, California
278. Hesperia, City of, California
279. Highland, City of, California
280. Hollister, City of, California
281. Humboldt, County of, California
282. Huntington Park, City of,  
California
283. Indio, City of, California
284. Inglewood, City of, California
285. Irvine, City of, California
286. Jurupa Valley, City of, California
287. Kern, County of, California
288. Kings, County of, California
289. La Habra, City of, California
290. La Mesa, City of, California
291. La Mirada, City of, California
292. La Puente, City of, California
293. La Quinta, City of, California
294. La Verne, City of, California
295. Laguna Hills, City of, California
296. Laguna Niguel, City of,  
California
297. Lake, County of, California
298. Lake Elsinore, City of, California
299. Lake Forest, City of, California
300. Lakewood, City of, California
301. Lancaster, City of, California
302. Lawndale, City of, California
303. Lincoln, City of, California
304. Livermore, City of, California
305. Lodi, City of, California
306. Lompoc, City of, California
307. Long Beach, City of, California
308. Los Altos, City of, California
309. Los Angeles, City of, California
310. Los Angeles, County of,  
California
311. Los Banos, City of, California
312. Los Gatos, Town of, California
313. Lynwood, City of, California
314. Madera, City of, California
315. Manhattan Beach, City of,  
California
316. Manteca, City of, California
317. Marin, County of, California
318. Martinez, City of, California
319. Menifee, City of, California
320. Menlo Park, City of, California
321. Merced, City of, California
322. Milpitas, City of, California
323. Mission Viejo, City of,  
California
324. Modesto, City of, California
325. Monrovia, City of, California
326. Montclair, City of, California
327. Montebello, City of, California
328. Monterey Park, City of,  
California
329. Moorpark, City of, California
330. Moreno Valley, City of,  
California
331. Morgan Hill, City of, California

- 332. Mountain View, City of, California
- 333. Murrieta, City of, California
- 334. Napa, City of, California
- 335. Napa, County of, California
- 336. National City, City of, California
- 337. Newark, City of, California
- 338. Newport Beach, City of, California
- 339. Norwalk, City of, California
- 340. Novato, City of, California
- 341. Oakland, City of, California
- 342. Oakley, City of, California
- 343. Oceanside, City of, California
- 344. Ontario, City of, California
- 345. Orange, City of, California
- 346. Orange, County of, California
- 347. Oxnard, City of, California
- 348. Pacifica, City of, California
- 349. Palm Desert, City of, California
- 350. Palm Springs, City of, California
- 351. Palmdale, City of, California
- 352. Palo Alto, City of, California
- 353. Paramount, City of, California
- 354. Pasadena, City of, California
- 355. Perris, City of, California
- 356. Petaluma, City of, California
- 357. Pico Rivera, City of, California
- 358. Pittsburg, City of, California
- 359. Placentia, City of, California
- 360. Pleasant Hill, City of, California
- 361. Pleasanton, City of, California
- 362. Pomona, City of, California
- 363. Porterville, City of, California
- 364. Poway, City of, California
- 365. Rancho Cordova, City of, California
- 366. Rancho Cucamonga, City of, California
- 367. Rancho Palos Verdes, City of, California
- 368. Rancho Santa Margarita, City of, California
- 369. Redding, City of, California
- 370. Redlands, City of, California
- 371. Redondo Beach, City of, California
- 372. Redwood City, City of, California
- 373. Rialto, City of, California
- 374. Richmond, City of, California
- 375. Riverside, City of, California
- 376. Rocklin, City of, California
- 377. Rohnert Park, City of, California
- 378. Rosemead, City of, California
- 379. Roseville, City of, California
- 380. Sacramento, City of, California
- 381. Salinas, City of, California
- 382. San Benito, County of, California
- 383. San Bernardino, City of, California
- 384. San Bruno, City of, California
- 385. San Buenaventura (Ventura), City of, California
- 386. San Carlos, City of, California
- 387. San Clemente, City of, California
- 388. San Diego, City of, California
- 389. San Dimas, City of, California
- 390. San Francisco, City of/ County of, California
- 391. San Gabriel, City of, California
- 392. San Jacinto, City of, California
- 393. San Joaquin, County of, California
- 394. San Juan Capistrano, City of, California
- 395. San Leandro, City of, California
- 396. San Luis Obispo, City of, California
- 397. San Marcos, City of, California
- 398. San Mateo, City of, California
- 399. San Mateo, County of, California
- 400. San Pablo, City of, California
- 401. San Rafael, City of, California
- 402. San Ramon, City of, California
- 403. Santa Ana, City of, California
- 404. Santa Barbara, City of, California
- 405. Santa Barbara, County of, California
- 406. Santa Clara, City of, California
- 407. Santa Clarita, City of, California

- 408. Santa Cruz, City of, California
- 409. Santa Cruz, County of, California
- 410. Santa Maria, City of, California
- 411. Santa Monica, City of, California
- 412. Santa Rosa, City of, California
- 413. Santee, City of, California
- 414. Saratoga, City of, California
- 415. Seaside, City of, California
- 416. Simi Valley, City of, California
- 417. Solano, County of, California
- 418. Sonoma, County of, California
- 419. South Gate, City of, California
- 420. South San Francisco, City of, California
- 421. Stanislaus, County of, California
- 422. Stanton, City of, California
- 423. Stockton, City of, California
- 424. Sunnyvale, City of, California
- 425. Temecula, City of, California
- 426. Temple City, City of, California
- 427. Thousand Oaks, City of, California
- 428. Torrance, City of, California
- 429. Tracy, City of, California
- 430. Tulare, City of, California
- 431. Turlock, City of, California
- 432. Tustin, City of, California
- 433. Union City, City of, California
- 434. Upland, City of, California
- 435. Vacaville, City of, California
- 436. Vallejo, City of, California
- 437. Ventura, County of, California
- 438. Victorville, City of, California
- 439. Visalia, City of, California
- 440. Vista, City of, California
- 441. Walnut Creek, City of, California
- 442. Watsonville, City of, California
- 443. West Covina, City of, California
- 444. West Hollywood, City of, California
- 445. West Sacramento, City of, California
- 446. Westminster, City of, California
- 447. Whittier, City of, California
- 448. Wildomar, City of, California
- 449. Woodland, City of, California
- 450. Yorba Linda, City of, California
- 451. Yuba City, City of, California
- 452. Yucaipa, City of, California
- 453. Adams, County of, Colorado
- 454. Arapahoe, County of, Colorado
- 455. Arvada, City of, Colorado
- 456. Aurora, City of, Colorado
- 457. Boulder, City of, Colorado
- 458. Boulder, County of, Colorado
- 459. Broomfield City of/ County of, Colorado
- 460. Castle Rock, Town of, Colorado
- 461. Centennial, City of, Colorado
- 462. Chaffee, County of, Colorado
- 463. Colorado Springs, City of, Colorado
- 464. Commerce City, City of, Colorado
- 465. Delta, County of, Colorado
- 466. Denver, City of/ County of, Colorado
- 467. Douglas, County of, Colorado
- 468. Eagle, County of, Colorado
- 469. El Paso, County of, Colorado
- 470. Englewood, City of, Colorado
- 471. Fort Collins, City of, Colorado
- 472. Fountain, City of, Colorado
- 473. Fremont, County of, Colorado
- 474. Garfield, County of, Colorado
- 475. Grand Junction, City of, Colorado
- 476. Jefferson, County of, Colorado
- 477. La Plata, County of, Colorado
- 478. Lafayette, City of, Colorado
- 479. Larimer, County of, Colorado
- 480. Las Animas, County of, Colorado
- 481. Littleton, City of, Colorado
- 482. Longmont, City of, Colorado
- 483. Loveland, City of, Colorado
- 484. Montrose, County of, Colorado
- 485. Northglenn, City of, Colorado
- 486. Otero, County of, Colorado
- 487. Parker, Town of, Colorado
- 488. Pueblo, City of, Colorado
- 489. Summit, County of, Colorado



- 490. Teller, County of, Colorado
- 491. Weld, County of, Colorado
- 492. Westminster, City of, Colorado
- 493. Wheat Ridge, City of, Colorado
- 494. Windsor, Town of, Colorado
- 495. Ansonia, City of, Connecticut
- 496. Danbury City of/ Town of, Connecticut
- 497. Derby, City of, Connecticut
- 498. Glastonbury, Town of, Connecticut
- 499. Greenwich, Town of, Connecticut
- 500. Groton, Town of, Connecticut
- 501. Hamden, Town of, Connecticut
- 502. Hartford, City of/ Town of, Connecticut
- 503. Manchester, Town of, Connecticut
- 504. Meriden, City of/ Town of, Connecticut
- 505. Milford, Town of, Connecticut
- 506. Monroe, Town of, Connecticut
- 507. Naugatuck, Borough of/ Town of, Connecticut
- 508. New Britain, Town of/ City of, Connecticut
- 509. New Haven, City of, Connecticut
- 510. New London, City of, Connecticut
- 511. Newington, Town of, Connecticut
- 512. Norwalk, City of/ Town of, Connecticut
- 513. Shelton, City of/ Town of, Connecticut
- 514. Stamford, City of/ Town of, Connecticut
- 515. Trumbull, Town of, Connecticut
- 516. Wallingford, Town of, Connecticut
- 517. West Hartford, Town of, Connecticut
- 518. Dover, City of, Delaware
- 519. Kent, County of, Delaware
- 520. New Castle, County of, Delaware
- 521. Newark, City of, Delaware
- 522. Wilmington, City of, Delaware
- 523. Altamonte Springs, City of, Florida
- 524. Aventura, City of, Florida
- 525. Boca Raton, City of, Florida
- 526. Bonita Springs, City of, Florida
- 527. Boynton Beach, City of, Florida
- 528. Calhoun, County of, Florida
- 529. Cape Coral, City of, Florida
- 530. Charlotte, County of, Florida
- 531. Citrus, County of, Florida
- 532. Clermont, City of, Florida
- 533. Collier, County of, Florida
- 534. Columbia, County of, Florida
- 535. Cooper City, City of, Florida
- 536. Coral Gables, City of, Florida
- 537. Cutler Bay, Town of, Florida
- 538. Dania Beach, City of, Florida
- 539. Davie, Town of, Florida
- 540. DeLand, City of, Florida
- 541. Delray Beach, City of, Florida
- 542. DeSoto, County of, Florida
- 543. Doral, City of, Florida
- 544. Dunedin, City of, Florida
- 545. Duval-Jacksonville County, Consolidated Government of, Florida
- 546. Estero, Village of, Florida
- 547. Flagler, County of, Florida
- 548. Fort Myers, City of, Florida
- 549. Gadsden, County of, Florida
- 550. Gainesville, City of, Florida
- 551. Greenacres, City of, Florida
- 552. Gulf, County of, Florida
- 553. Hendry, County of, Florida
- 554. Hernando, County of, Florida
- 555. Hialeah, City of, Florida
- 556. Highlands, County of, Florida
- 557. Hillsborough, County of, Florida
- 558. Hollywood, City of, Florida
- 559. Holmes, County of, Florida
- 560. Indian River, County of, Florida
- 561. Jupiter, Town of, Florida
- 562. Kissimmee, City of, Florida
- 563. Lake Worth, City of, Florida

- 564. Lakeland, City of, Florida
- 565. Largo, City of, Florida
- 566. Lauderdale Lakes, City of, Florida
- 567. Margate, City of, Florida
- 568. Martin, County of, Florida
- 569. Melbourne, City of, Florida
- 570. Miami Beach, City of, Florida
- 571. Miami, City of, Florida
- 572. Miami Lakes, Town of, Florida
- 573. Nassau, County of, Florida
- 574. North Lauderdale, City of, Florida
- 575. North Miami Beach, City of, Florida
- 576. North Port, City of, Florida
- 577. Oakland Park, City of, Florida
- 578. Okeechobee, County of, Florida
- 579. Palm Beach Gardens, City of, Florida
- 580. Palm Coast, City of, Florida
- 581. Parkland, City of, Florida
- 582. Plant City, City of, Florida
- 583. Plantation, City of, Florida
- 584. Polk, County of, Florida
- 585. Port Orange, City of, Florida
- 586. Riviera Beach, City of, Florida
- 587. Royal Palm Beach, Village of, Florida
- 588. Sarasota, County of, Florida
- 589. St. Cloud, City of, Florida
- 590. Stuart, City of, Florida
- 591. Sumter, County of, Florida
- 592. Sunrise, City of, Florida
- 593. Tamarac, City of, Florida
- 594. Tampa, City of, Florida
- 595. Titusville, City of, Florida
- 596. Wakulla, County of, Florida
- 597. Washington, County of, Florida
- 598. Wellington, Village of, Florida
- 599. West Palm Beach, City of, Florida
- 600. Weston, City of, Florida
- 601. Winter Garden, City of, Florida
- 602. Winter Haven, City of, Florida
- 603. Winter Park, City of, Florida
- 604. Winter Springs, City of, Florida
- 605. Alpharetta, City of, Georgia
- 606. Augusta-Richmond County, Consolidated Government of, Georgia
- 607. Bacon, County of, Georgia
- 608. Barrow, County of, Georgia
- 609. Berrien, County of, Georgia
- 610. Brookhaven, City of, Georgia
- 611. Brooks, County of, Georgia
- 612. Brunswick, City of, Georgia
- 613. Bryan, County of, Georgia
- 614. Calhoun, City of, Georgia
- 615. Canton, City of, Georgia
- 616. Cartersville, City of, Georgia
- 617. Chamblee, City of, Georgia
- 618. Chatham, County of, Georgia
- 619. Chattooga, County of, Georgia
- 620. Colquitt, County of, Georgia
- 621. Coweta, County of, Georgia
- 622. Crawford, County of, Georgia
- 623. Dalton, City of, Georgia
- 624. Doraville, City of, Georgia
- 625. Douglas, County of, Georgia
- 626. Douglasville, City of, Georgia
- 627. Dunwoody, City of, Georgia
- 628. East Point, City of, Georgia
- 629. Fannin, County of, Georgia
- 630. Floyd, County of, Georgia
- 631. Gilmer, County of, Georgia
- 632. Gordon, County of, Georgia
- 633. Harris, County of, Georgia
- 634. Heard, County of, Georgia
- 635. Hinesville, City of, Georgia
- 636. Johns Creek, City of, Georgia
- 637. Kennesaw, City of, Georgia
- 638. LaGrange, City of, Georgia
- 639. Lawrenceville, City of, Georgia
- 640. Marietta, City of, Georgia
- 641. McDonough, City of, Georgia
- 642. Meriwether, County of, Georgia
- 643. Milton, City of, Georgia
- 644. Moultrie, City of, Georgia
- 645. Murray, County of, Georgia
- 646. Newnan, City of, Georgia
- 647. Paulding, County of, Georgia

- 648. Peach, County of, Georgia
- 649. Peachtree City, City of, Georgia
- 650. Peachtree Corners, City of, Georgia
- 651. Pickens, County of, Georgia
- 652. Pierce, County of, Georgia
- 653. Pooler, City of, Georgia
- 654. Richmond Hill, City of, Georgia
- 655. Roswell, City of, Georgia
- 656. Sandy Springs, City of, Georgia
- 657. Smyrna, City of, Georgia
- 658. Snellville, City of, Georgia
- 659. South Fulton, City of, Georgia
- 660. Statesboro, City of, Georgia
- 661. Stonecrest, City of, Georgia
- 662. Telfair, County of, Georgia
- 663. Thomas, County of, Georgia
- 664. Tucker, City of, Georgia
- 665. Valdosta, City of, Georgia
- 666. Villa Rica, City of, Georgia
- 667. Walker, County of, Georgia
- 668. Warner Robins, City of, Georgia
- 669. White, County of, Georgia
- 670. Whitfield, County of, Georgia
- 671. Winder, City of, Georgia
- 672. Woodstock, City of, Georgia
- 673. Hawaii, County of, Hawaii
- 674. Honolulu, County of, Hawaii
- 675. Kauai, County of, Hawaii
- 676. Maui, County of, Hawaii
- 677. Hawai'i, County of, Hawai'i
- 678. Kaua'i, County of, Hawai'i
- 679. Bannock, County of, Idaho
- 680. Boise, City of, Idaho
- 681. Boise City, City of, Idaho
- 682. Bonner, County of, Idaho
- 683. Caldwell, City of, Idaho
- 684. Chubbuck, City of, Idaho
- 685. Coeur d'Alene, City of, Idaho
- 686. Idaho Falls, City of, Idaho
- 687. Kootenai, County of, Idaho
- 688. Lewiston, City of, Idaho
- 689. Madison, County of, Idaho
- 690. Meridian, City of, Idaho
- 691. Nampa, City of, Idaho
- 692. Nez Perce, County of, Idaho
- 693. Pocatello, City of, Idaho
- 694. Post Falls, City of, Idaho
- 695. Twin Falls, City of, Idaho
- 696. Twin Falls, County of, Idaho
- 697. Adams, County of, Illinois
- 698. Addison, Township of, Illinois
- 699. Addison, Village of, Illinois
- 700. Algonquin, Township of, Illinois
- 701. Algonquin, Village of, Illinois
- 702. Arlington Heights, Village of, Illinois
- 703. Aurora, City of, Illinois
- 704. Aurora, Township of, Illinois
- 705. Avon, Township of, Illinois
- 706. Bartlett, Village of, Illinois
- 707. Batavia, Township of, Illinois
- 708. Belleville, City of, Illinois
- 709. Bellwood, Village of, Illinois
- 710. Bensenville, Village of, Illinois
- 711. Berwyn, City of, Illinois
- 712. Berwyn, Township of, Illinois
- 713. Bloom, Township of, Illinois
- 714. Bloomingdale, Township of, Illinois
- 715. Bloomington, City of, Illinois
- 716. Bloomington City, Township of, Illinois
- 717. Bolingbrook, Village of, Illinois
- 718. Bond, County of, Illinois
- 719. Bourbonnais, Township of, Illinois
- 720. Bremen, Township of, Illinois
- 721. Bridgeview, Village of, Illinois
- 722. Bristol, Township of, Illinois
- 723. Buffalo Grove, Village of, Illinois
- 724. Burbank, City of, Illinois
- 725. Calumet City, City of, Illinois
- 726. Capital, Township of, Illinois
- 727. Carbondale, City of, Illinois
- 728. Carol Stream, Village of, Illinois
- 729. Carpentersville, Village of, Illinois
- 730. Caseyville, Township of, Illinois
- 731. Champaign, City of, Illinois

- 732. Champaign City, Township of, Illinois
- 733. Chicago Heights, City of, Illinois
- 734. Chicago Ridge, Village of, Illinois
- 735. Cicero, Town of/ Township of, Illinois
- 736. Clinton, County of, Illinois
- 737. Collinsville, Township of, Illinois
- 738. Crystal Lake, City of, Illinois
- 739. Cunningham, Township of, Illinois
- 740. Danville, City of, Illinois
- 741. Decatur, City of, Illinois
- 742. Decatur, Township of, Illinois
- 743. DeKalb, City of, Illinois
- 744. DeKalb, Township of, Illinois
- 745. Des Plaines, City of, Illinois
- 746. Dolton, Village of, Illinois
- 747. Downers Grove, Township of, Illinois
- 748. Downers Grove, Village of, Illinois
- 749. Dundee, Township of, Illinois
- 750. DuPage, Township of, Illinois
- 751. Edwardsville, Township of, Illinois
- 752. Ela, Township of, Illinois
- 753. Elgin, City of, Illinois
- 754. Elgin, Township of, Illinois
- 755. Elk Grove, Township of, Illinois
- 756. Elk Grove Village, Village of, Illinois
- 757. Elmhurst, City of, Illinois
- 758. Evanston, City of, Illinois
- 759. Evergreen Park, Village of, Illinois
- 760. Forest Park, Village of, Illinois
- 761. Frankfort, Township of, Illinois
- 762. Franklin Park, Village of, Illinois
- 763. Fremont, Township of, Illinois
- 764. Fulton, County of, Illinois
- 765. Galesburg, City of, Illinois
- 766. Galesburg City, Township of, Illinois
- 767. Glendale Heights, Village of, Illinois
- 768. Glenview, Village of, Illinois
- 769. Grafton, Township of, Illinois
- 770. Granite City, City of, Illinois
- 771. Granite City, Township of, Illinois
- 772. Grundy, County of, Illinois
- 773. Gurnee, Village of, Illinois
- 774. Hanover Park, Village of, Illinois
- 775. Hanover, Township of, Illinois
- 776. Harlem, Township of, Illinois
- 777. Harvey, City of, Illinois
- 778. Harwood Heights, Village of, Illinois
- 779. Hoffman Estates, Village of, Illinois
- 780. Homer, Township of, Illinois
- 781. Jackson, County of, Illinois
- 782. Joliet, City of, Illinois
- 783. Joliet, Township of, Illinois
- 784. Kankakee, City of, Illinois
- 785. Knox, County of, Illinois
- 786. La Grange Park, Village of, Illinois
- 787. Lake, County of, Illinois
- 788. Lake Villa, Township of, Illinois
- 789. LaSalle, County of, Illinois
- 790. Leyden, Township of, Illinois
- 791. Libertyville, Township of, Illinois
- 792. Lisle, Township of, Illinois
- 793. Lockport, Township of, Illinois
- 794. Lombard, Village of, Illinois
- 795. Lyons, Township of, Illinois
- 796. Lyons, Village of, Illinois
- 797. Madison, County of, Illinois
- 798. Maine, Township of, Illinois
- 799. Massac, County of, Illinois
- 800. Maywood, Village of, Illinois
- 801. McHenry, Township of, Illinois
- 802. McLean, County of, Illinois
- 803. Melrose Park, Village of, Illinois
- 804. Milton, Township of, Illinois
- 805. Moline, City of, Illinois
- 806. Monroe, County of, Illinois

- 807. Moraine, Township of, Illinois
- 808. Morgan, County of, Illinois
- 809. Mount Prospect, Village of, Illinois
- 810. Mundelein, Village of, Illinois
- 811. Naperville, City of, Illinois
- 812. Naperville, Township of, Illinois
- 813. New Lenox, Township of, Illinois
- 814. New Trier, Township of, Illinois
- 815. Niles, Township of, Illinois
- 816. Normal, Town of, Illinois
- 817. Normal, Township of, Illinois
- 818. Northbrook, Village of, Illinois
- 819. Northfield, Township of, Illinois
- 820. Northlake, City of, Illinois
- 821. Nunda, Township of, Illinois
- 822. Oak Lawn, Village of, Illinois
- 823. Oak Park, Township of, Illinois
- 824. Oak Park, Village of, Illinois
- 825. Ogle, County of, Illinois
- 826. Orland Park, Village of, Illinois
- 827. Orland, Township of, Illinois
- 828. Oswego, Township of, Illinois
- 829. Oswego, Village of, Illinois
- 830. Palatine, Township of, Illinois
- 831. Palatine, Village of, Illinois
- 832. Palos Heights, City of, Illinois
- 833. Palos Hills, City of, Illinois
- 834. Palos, Township of, Illinois
- 835. Park Ridge, City of, Illinois
- 836. Pekin, City of, Illinois
- 837. Peoria, City of, Illinois
- 838. Peoria City, Township of, Illinois
- 839. Peoria, County of, Illinois
- 840. Plainfield, Township of, Illinois
- 841. Plainfield, Village of, Illinois
- 842. Proviso, Township of, Illinois
- 843. Quincy, City of, Illinois
- 844. Quincy, Township of, Illinois
- 845. Randolph, County of, Illinois
- 846. Rich, Township of, Illinois
- 847. River Forest, Village of, Illinois
- 848. River Grove, Village of, Illinois
- 849. Rock Island, City of, Illinois
- 850. Rockford, Township of, Illinois
- 851. Romeoville, Village of, Illinois
- 852. Schaumburg, Township of, Illinois
- 853. Schaumburg, Village of, Illinois
- 854. Schiller Park, Village of, Illinois
- 855. Shields, Township of, Illinois
- 856. Skokie, Village of, Illinois
- 857. South Moline, Township of, Illinois
- 858. Springfield, City of, Illinois
- 859. St. Charles, City of, Illinois
- 860. St. Charles, Township of, Illinois
- 861. St. Clair, County of, Illinois
- 862. St. Clair, Township of, Illinois
- 863. Stickney, Township of, Illinois
- 864. Streamwood, Village of, Illinois
- 865. Streator, City of, Illinois
- 866. Summit, Village of, Illinois
- 867. Tazewell, County of, Illinois
- 868. Thornton, Township of, Illinois
- 869. Tinley Park, Village of, Illinois
- 870. Troy, Township of, Illinois
- 871. Urbana, City of, Illinois
- 872. Vermilion, County of, Illinois
- 873. Vernon, Township of, Illinois
- 874. Wabash, County of, Illinois
- 875. Warren, Township of, Illinois
- 876. Washington, County of, Illinois
- 877. Waukegan, City of, Illinois
- 878. Waukegan, Township of, Illinois
- 879. Wayne, Township of, Illinois
- 880. West Deerfield, Township of, Illinois
- 881. Wheatland, Township of, Illinois
- 882. Wheaton, City of, Illinois
- 883. Wheeling, Township of, Illinois
- 884. Wheeling, Village of, Illinois
- 885. Whiteside, County of, Illinois
- 886. Williamson, County of, Illinois
- 887. Winfield, Township of, Illinois
- 888. Wood River, Township of, Illinois
- 889. Woodford, County of, Illinois
- 890. Woodridge, Village of, Illinois
- 891. Worth, Township of, Illinois
- 892. York, Township of, Illinois

- 893. Aboite, Township of, Indiana
- 894. Adams, County of, Indiana
- 895. Adams, Township of, Indiana
- 896. Anderson, City of, Indiana
- 897. Anderson, Township of, Indiana
- 898. Bartholomew, County of, Indiana
- 899. Blackford, County of, Indiana
- 900. Bloomington, Township of, Indiana
- 901. Boone, County of, Indiana
- 902. Calumet, Township of, Indiana
- 903. Carmel, City of, Indiana
- 904. Cass, County of, Indiana
- 905. Clark, County of, Indiana
- 906. Clinton, County of, Indiana
- 907. Columbus, City of, Indiana
- 908. Columbus, Township of, Indiana
- 909. Concord, Township of, Indiana
- 910. Crown Point, City of, Indiana
- 911. Daviess, County of, Indiana
- 912. Dearborn, County of, Indiana
- 913. Decatur, Township of, Indiana
- 914. DeKalb, County of, Indiana
- 915. Delaware, Township of, Indiana
- 916. Dubois, County of, Indiana
- 917. Elkhart, City of, Indiana
- 918. Elkhart, County of, Indiana
- 919. Elkhart, Township of, Indiana
- 920. Fairfield, Township of, Indiana
- 921. Fall Creek, Township of, Indiana
- 922. Fayette, County of, Indiana
- 923. Floyd, County of, Indiana
- 924. Franklin, Township of, Indiana
- 925. Gibson, County of, Indiana
- 926. Goshen, City of, Indiana
- 927. Grant, County of, Indiana
- 928. Greene, County of, Indiana
- 929. Guilford, Township of, Indiana
- 930. Hamilton, County of, Indiana
- 931. Hancock, County of, Indiana
- 932. Harrison, Township of, Indiana
- 933. Hendricks, County of, Indiana
- 934. Henry, County of, Indiana
- 935. Hobart, Township of, Indiana
- 936. Huntington, County of, Indiana
- 937. Jasper, County of, Indiana
- 938. Jay, County of, Indiana
- 939. Jefferson, County of, Indiana
- 940. Jeffersonville, Township of, Indiana
- 941. Johnson, County of, Indiana
- 942. Knight, Township of, Indiana
- 943. Knox, County of, Indiana
- 944. Kokomo, City of, Indiana
- 945. Kosciusko, County of, Indiana
- 946. LaGrange, County of, Indiana
- 947. Lawrence, Township of, Indiana
- 948. Lincoln, Township of, Indiana
- 949. Merrillville, Town of, Indiana
- 950. Miami, County of, Indiana
- 951. Michigan City, City of, Indiana
- 952. Mishawaka, City of, Indiana
- 953. Monroe, County of, Indiana
- 954. Montgomery, County of, Indiana
- 955. New Albany, Township of, Indiana
- 956. Noble, County of, Indiana
- 957. Noblesville, Township of, Indiana
- 958. North, Township of, Indiana
- 959. Ohio, Township of, Indiana
- 960. Orange, County of, Indiana
- 961. Penn, Township of, Indiana
- 962. Peru, City of, Indiana
- 963. Pike, Township of, Indiana
- 964. Pleasant, Township of, Indiana
- 965. Portage, City of, Indiana
- 966. Putnam, County of, Indiana
- 967. Richmond, City of, Indiana
- 968. Ross, Township of, Indiana
- 969. Shelby, County of, Indiana
- 970. Shelbyville, City of, Indiana
- 971. St. John, Township of, Indiana
- 972. St. Joseph, Township of, Indiana
- 973. Starke, County of, Indiana
- 974. Steuben, County of, Indiana
- 975. Valparaiso, City of, Indiana
- 976. Wabash, County of, Indiana
- 977. Wabash, Township of, Indiana
- 978. Warren, Township of, Indiana
- 979. Warrick, County of, Indiana
- 980. Wayne, County of, Indiana

- 981. Wea, Township of, Indiana
- 982. White River, Township of, Indiana
- 983. Whitley, County of, Indiana
- 984. Ames, City of, Iowa
- 985. Ankeny, City of, Iowa
- 986. Bettendorf, City of, Iowa
- 987. Cedar Falls, City of, Iowa
- 988. Cedar Rapids, City of, Iowa
- 989. Council Bluffs, City of, Iowa
- 990. Davenport, City of, Iowa
- 991. Des Moines, City of, Iowa
- 992. Dubuque, City of, Iowa
- 993. Dubuque, County of, Iowa
- 994. Iowa City, City of, Iowa
- 995. Linn, County of, Iowa
- 996. Marion, City of, Iowa
- 997. Marshall, County of, Iowa
- 998. O'Brien, County of, Iowa
- 999. Sioux City, City of, Iowa
- 1000. Story, County of, Iowa
- 1001. Urbandale, City of, Iowa
- 1002. Wapello, County of, Iowa
- 1003. Warren, County of, Iowa
- 1004. Waterloo, City of, Iowa
- 1005. West Des Moines, City of, Iowa
- 1006. Woodbury, County of, Iowa
- 1007. Butler, County of, Kansas
- 1008. Douglas, County of, Kansas
- 1009. Geary, County of, Kansas
- 1010. Hutchinson, City of, Kansas
- 1011. Lawrence, City of, Kansas
- 1012. Leavenworth, City of, Kansas
- 1013. Leawood, City of, Kansas
- 1014. Lenexa, City of, Kansas
- 1015. Lyon, County of, Kansas
- 1016. Manhattan, City of, Kansas
- 1017. Miami, County of, Kansas
- 1018. Olathe, City of, Kansas
- 1019. Riley, County of, Kansas
- 1020. Salina, City of, Kansas
- 1021. Saline, County of, Kansas
- 1022. Shawnee, City of, Kansas
- 1023. Shawnee, County of, Kansas
- 1024. Topeka, City of, Kansas
- 1025. Allen, County of, Kentucky
- 1026. Barren, County of, Kentucky
- 1027. Bath, County of, Kentucky
- 1028. Bowling Green, City of, Kentucky
- 1029. Breathitt, County of, Kentucky
- 1030. Bullitt, County of, Kentucky
- 1031. Caldwell, County of, Kentucky
- 1032. Calloway, County of, Kentucky
- 1033. Campbellsville, City of, Kentucky
- 1034. Carter, County of, Kentucky
- 1035. Casey, County of, Kentucky
- 1036. Clay, County of, Kentucky
- 1037. Daviess, County of, Kentucky
- 1038. Elizabethtown, City of, Kentucky
- 1039. Fleming, County of, Kentucky
- 1040. Florence, City of, Kentucky
- 1041. Garrard, County of, Kentucky
- 1042. Georgetown, City of, Kentucky
- 1043. Graves, County of, Kentucky
- 1044. Greenup, County of, Kentucky
- 1045. Harrison, County of, Kentucky
- 1046. Hart, County of, Kentucky
- 1047. Henderson, City of, Kentucky
- 1048. Henry, County of, Kentucky
- 1049. Hopkinsville, City of, Kentucky
- 1050. Larue, County of, Kentucky
- 1051. Laurel, County of, Kentucky
- 1052. Leslie, County of, Kentucky
- 1053. Lewis, County of, Kentucky
- 1054. Logan, County of, Kentucky
- 1055. Martin, County of, Kentucky
- 1056. Mason, County of, Kentucky
- 1057. Mercer, County of, Kentucky
- 1058. Morgan, County of, Kentucky
- 1059. Mount Washington, City of, Kentucky
- 1060. Muhlenberg, County of, Kentucky
- 1061. Murray, City of, Kentucky
- 1062. Nelson, County of, Kentucky
- 1063. Nicholasville, City of, Kentucky
- 1064. Owen, County of, Kentucky
- 1065. Owensboro, City of, Kentucky
- 1066. Pendleton, County of, Kentucky
- 1067. Powell, County of, Kentucky

- 1068. Richmond, City of, Kentucky
- 1069. Russell, County of, Kentucky
- 1070. Shepherdsville, City of, Kentucky
- 1071. Spencer, County of, Kentucky
- 1072. Taylor, County of, Kentucky
- 1073. Todd, County of, Kentucky
- 1074. Webster, County of, Kentucky
- 1075. Winchester, City of, Kentucky
- 1076. Woodford, County of, Kentucky
- 1077. Acadia, Parish of, Louisiana
- 1078. Bienville, Parish of, Louisiana
- 1079. Bossier City, City of, Louisiana
- 1080. Covington, City of, Louisiana
- 1081. De Soto, Parish of, Louisiana
- 1082. Gretna, City of, Louisiana
- 1083. Iberville, Parish of, Louisiana
- 1084. Lafayette, City of, Louisiana
- 1085. Lincoln, Parish of, Louisiana
- 1086. Livingston, Parish of, Louisiana
- 1087. Morgan, City of, Louisiana
- 1088. Tangipahoa, Parish of, Louisiana
- 1089. Terrebonne, Parish of, Louisiana
- 1090. West Monroe, City of, Louisiana
- 1091. Franklin, County of, Maine
- 1092. Hancock, County of, Maine
- 1093. Oxford, County of, Maine
- 1094. Annapolis, City of, Maryland
- 1095. Anne Arundel, County of, Maryland
- 1096. Baltimore, City of, Maryland
- 1097. Baltimore, County of, Maryland
- 1098. Carroll, County of, Maryland
- 1099. College Park, City of, Maryland
- 1100. Gaithersburg, City of, Maryland
- 1101. Grantsville, City of, Maryland
- 1102. Howard, County of, Maryland
- 1103. Montgomery, County of, Maryland
- 1104. Queen Anne's, County of, Maryland
- 1105. Salisbury, City of, Maryland
- 1106. Worcester, County of, Maryland
- 1107. Amherst, Town of, Massachusetts
- 1108. Andover, Town of, Massachusetts
- 1109. Arlington, Town of, Massachusetts
- 1110. Attleboro, City of, Massachusetts
- 1111. Barnstable, County of, Massachusetts
- 1112. Barnstable, Town of/ City of, Massachusetts
- 1113. Boston, City of, Massachusetts
- 1114. Braintree, Town of, Massachusetts
- 1115. Braintree, Town of/ City of, Massachusetts
- 1116. Bristol, County of, Massachusetts
- 1117. Chelsea, City of, Massachusetts
- 1118. Dartmouth, Town of, Massachusetts
- 1119. Dracut, Town of, Massachusetts
- 1120. Fall River, City of, Massachusetts
- 1121. Franklin, Town of/ City of, Massachusetts
- 1122. Lawrence, City of, Massachusetts
- 1123. Lexington, Town of, Massachusetts
- 1124. Marlborough, City of, Massachusetts
- 1125. Nantucket, Town of/ County of, Massachusetts
- 1126. Needham, Town of, Massachusetts
- 1127. New Bedford, City of, Massachusetts
- 1128. Newton, City of, Massachusetts
- 1129. Norfolk, County of, Massachusetts
- 1130. Plymouth, County of, Massachusetts
- 1131. Quincy, City of, Massachusetts
- 1132. Randolph, Town of/ City of, Massachusetts
- 1133. Revere, City of, Massachusetts



- 1134. Shrewsbury, Town of, Massachusetts
- 1135. Somerville, City of, Massachusetts
- 1136. Spencer, Town of, Massachusetts
- 1137. Taunton, City of, Massachusetts
- 1138. Waltham, City of, Massachusetts
- 1139. Westfield, City of, Massachusetts
- 1140. Weymouth, Town of/ City of, Massachusetts
- 1141. Winthrop, Town of/ City of, Massachusetts
- 1142. Allegan, County of, Michigan
- 1143. Ann Arbor, City of, Michigan
- 1144. Barry, County of, Michigan
- 1145. Battle Creek, City of, Michigan
- 1146. Bay City, City of, Michigan
- 1147. Bay, County of, Michigan
- 1148. Bedford, Township of, Michigan
- 1149. Bloomfield, Charter Township of, Michigan
- 1150. Brownstown, Charter Township of, Michigan
- 1151. Cheboygan, County of, Michigan
- 1152. Chesterfield, Township of, Michigan
- 1153. Clare, County of, Michigan
- 1154. Clinton, Charter Township of, Michigan
- 1155. Commerce, Charter Township of, Michigan
- 1156. Dearborn, City of, Michigan
- 1157. Dearborn Heights, City of, Michigan
- 1158. Delta, Charter Township of, Michigan
- 1159. Eastpointe, City of, Michigan
- 1160. Emmet, County of, Michigan
- 1161. Farmington Hills, City of, Michigan
- 1162. Flint, Charter Township of, Michigan
- 1163. Flint, City of, Michigan
- 1164. Georgetown, Charter Township of, Michigan
- 1165. Grand Blanc, Charter Township of, Michigan
- 1166. Harrison, Charter Township of, Michigan
- 1167. Holland, Charter Township of, Michigan
- 1168. Holland, City of, Michigan
- 1169. Huron, County of, Michigan
- 1170. Independence, Charter Township of, Michigan
- 1171. Jackson, County of, Michigan
- 1172. Kalamazoo, City of, Michigan
- 1173. Kentwood, City of, Michigan
- 1174. Lapeer, County of, Michigan
- 1175. Lincoln Park, City of, Michigan
- 1176. Macomb, Township of, Michigan
- 1177. Mecosta, County of, Michigan
- 1178. Meridian, Charter Township of, Michigan
- 1179. Midland, City of, Michigan
- 1180. Midland, County of, Michigan
- 1181. Muskegon, City of, Michigan
- 1182. Northville, Charter Township of, Michigan
- 1183. Novi, City of, Michigan
- 1184. Oakland, County of, Michigan
- 1185. Orion, Charter Township of, Michigan
- 1186. Ottawa, County of, Michigan
- 1187. Plainfield, Charter Township of, Michigan
- 1188. Portage, City of, Michigan
- 1189. Redford, Charter Township of, Michigan
- 1190. Rochester Hills, City of, Michigan
- 1191. Roseville, City of, Michigan
- 1192. Royal Oak, City of, Michigan
- 1193. Saginaw, Charter Township of, Michigan
- 1194. Saginaw, City of, Michigan
- 1195. Shelby, Charter Township of, Michigan
- 1196. Southfield, City of, Michigan
- 1197. St. Clair Shores, City of, Michigan

- 1198. St. Joseph, County of, Michigan
- 1199. Sterling Heights, City of,  
Michigan
- 1200. Taylor, City of, Michigan
- 1201. Troy, City of, Michigan
- 1202. Van Buren, County of, Michigan
- 1203. Warren, City of, Michigan
- 1204. Waterford, Charter Township of,  
Michigan
- 1205. Wayne, County of, Michigan
- 1206. West Bloomfield, Charter  
Township of, Michigan
- 1207. White Lake, Charter Township  
of, Michigan
- 1208. Wyoming, City of, Michigan
- 1209. Ypsilanti, Charter Township of,  
Michigan
- 1210. Andover, City of, Minnesota
- 1211. Apple Valley, City of, Minnesota
- 1212. Becker, County of, Minnesota
- 1213. Beltrami, County of, Minnesota
- 1214. Benton, County of, Minnesota
- 1215. Blaine, City of, Minnesota
- 1216. Bloomington, City of, Minnesota
- 1217. Blue Earth, County of,  
Minnesota
- 1218. Brooklyn Center, City of,  
Minnesota
- 1219. Brooklyn Park, City of,  
Minnesota
- 1220. Burnsville, City of, Minnesota
- 1221. Carlton, County of, Minnesota
- 1222. Carver, County of, Minnesota
- 1223. Chisago, County of, Minnesota
- 1224. Clay, County of, Minnesota
- 1225. Coon Rapids, City of, Minnesota
- 1226. Cottage Grove, City of,  
Minnesota
- 1227. Crow Wing, County of,  
Minnesota
- 1228. Duluth, City of, Minnesota
- 1229. Eagan, City of, Minnesota
- 1230. Eden Prairie, City of, Minnesota
- 1231. Edina, City of, Minnesota
- 1232. Freeborn, County of, Minnesota
- 1233. Goodhue, County of, Minnesota
- 1234. Hennepin, County of, Minnesota
- 1235. Inver Grove Heights, City of,  
Minnesota
- 1236. Isanti, County of, Minnesota
- 1237. Kandiyohi, County of, Minnesota
- 1238. Lakeville, City of, Minnesota
- 1239. Mankato, City of, Minnesota
- 1240. Maple Grove, City of, Minnesota
- 1241. Maplewood, City of, Minnesota
- 1242. Minneapolis, City of, Minnesota
- 1243. Minnetonka, City of, Minnesota
- 1244. Moorhead, City of, Minnesota
- 1245. Nicollet, County of, Minnesota
- 1246. North St. Paul, City of,  
Minnesota
- 1247. Olmsted, County of, Minnesota
- 1248. Otter Tail, County of, Minnesota
- 1249. Pine, County of, Minnesota
- 1250. Plymouth, City of, Minnesota
- 1251. Polk, County of, Minnesota
- 1252. Ramsey, County of, Minnesota
- 1253. Rice, County of, Minnesota
- 1254. Richfield, City of, Minnesota
- 1255. Rochester, City of, Minnesota
- 1256. Roseau, County of, Minnesota
- 1257. Roseville, City of, Minnesota
- 1258. Savage, City of, Minnesota
- 1259. Scott, County of, Minnesota
- 1260. Shakopee, City of, Minnesota
- 1261. Sherburne, County of, Minnesota
- 1262. Sibley, County of, Minnesota
- 1263. St. Cloud, City of, Minnesota
- 1264. St. Louis Park, City of,  
Minnesota
- 1265. Stearns, County of, Minnesota
- 1266. Steele, County of, Minnesota
- 1267. Waseca, County of, Minnesota
- 1268. Woodbury, City of, Minnesota
- 1269. Wright, County of, Minnesota
- 1270. Alcorn, County of, Mississippi
- 1271. Attala, County of, Mississippi
- 1272. Biloxi, City of, Mississippi
- 1273. Chickasaw, County of,  
Mississippi
- 1274. Clarke, County of, Mississippi
- 1275. Cleveland, City of, Mississippi

- 1276. Columbus, City of, Mississippi
- 1277. Copiah, County of, Mississippi
- 1278. Gautier, City of, Mississippi
- 1279. George, County of, Mississippi
- 1280. Greene, County of, Mississippi
- 1281. Hancock, County of, Mississippi
- 1282. Holmes, County of, Mississippi
- 1283. Itawamba, County of,  
Mississippi
- 1284. Jackson, County of, Mississippi
- 1285. Jefferson Davis, County of,  
Mississippi
- 1286. Jones, County of, Mississippi
- 1287. Lamar, County of, Mississippi
- 1288. Lauderdale, County of,  
Mississippi
- 1289. Lawrence, County of,  
Mississippi
- 1290. Lee, County of, Mississippi
- 1291. Lowndes, County of, Mississippi
- 1292. Moss Point, City of, Mississippi
- 1293. Ocean Springs, City of,  
Mississippi
- 1294. Oktibbeha, County of,  
Mississippi
- 1295. Olive Branch, City of,  
Mississippi
- 1296. Panola, County of, Mississippi
- 1297. Perry, County of, Mississippi
- 1298. Pike, County of, Mississippi
- 1299. Pontotoc, County of, Mississippi
- 1300. Rankin, County of, Mississippi
- 1301. Southaven, City of, Mississippi
- 1302. Starkville, City of, Mississippi
- 1303. Tallahatchie, County of,  
Mississippi
- 1304. Tate, County of, Mississippi
- 1305. Tishomingo, County of,  
Mississippi
- 1306. Tupelo, City of, Mississippi
- 1307. Vicksburg, City of, Mississippi
- 1308. Walthall, County of, Mississippi
- 1309. Warren, County of, Mississippi
- 1310. Wayne, County of, Mississippi
- 1311. Yalobusha, County of,  
Mississippi
- 1312. Adair, County of, Missouri
- 1313. Andrew, County of, Missouri
- 1314. Ballwin, City of, Missouri
- 1315. Blue Springs, City of, Missouri
- 1316. Cape Girardeau, City of,  
Missouri
- 1317. Chesterfield, City of, Missouri
- 1318. Clay, County of, Missouri
- 1319. Columbia, City of, Missouri
- 1320. DeKalb, County of, Missouri
- 1321. Florissant, City of, Missouri
- 1322. Harrisonville, City of, Missouri
- 1323. Jefferson City, City of, Missouri
- 1324. Kansas City, City of, Missouri
- 1325. Laclede, County of, Missouri
- 1326. Lee's Summit, City of, Missouri
- 1327. Liberty, City of, Missouri
- 1328. New Madrid, County of,  
Missouri
- 1329. Newton, County of, Missouri
- 1330. O'Fallon, City of, Missouri
- 1331. Platte, County of, Missouri
- 1332. Ralls, County of, Missouri
- 1333. St. Charles, City of, Missouri
- 1334. St. Louis, City of, Missouri
- 1335. St. Peters, City of, Missouri
- 1336. University City, City of,  
Missouri
- 1337. Wentzville, City of, Missouri
- 1338. Wildwood, City of, Missouri
- 1339. Billings, City of, Montana
- 1340. Bozeman, City of, Montana
- 1341. Butte-Silver Bow County,  
Consolidated Government of,  
Montana
- 1342. Flathead, County of, Montana
- 1343. Gallatin, County of, Montana
- 1344. Helena, City of, Montana
- 1345. Lake, County of, Montana
- 1346. Lewis and Clark, County of,  
Montana
- 1347. Missoula, City of, Montana
- 1348. Ravalli, County of, Montana
- 1349. Yellowstone, County of,  
Montana
- 1350. Adams, County of, Nebraska

- 1351. Bellevue, City of, Nebraska
- 1352. Buffalo, County of, Nebraska
- 1353. Dodge, County of, Nebraska
- 1354. Grand Island, City of, Nebraska
- 1355. Hall, County of, Nebraska
- 1356. Kearney, City of, Nebraska
- 1357. Lancaster, County of, Nebraska
- 1358. Lincoln, City of, Nebraska
- 1359. Madison, County of, Nebraska
- 1360. Omaha, City of, Nebraska
- 1361. Platte, County of, Nebraska
- 1362. Scotts Bluff, County of, Nebraska
- 1363. Boulder City, City of, Nevada
- 1364. Elko, County of, Nevada
- 1365. Lyon, County of, Nevada
- 1366. Mesquite, City of, Nevada
- 1367. Reno, City of, Nevada
- 1368. Claremont, City of, New Hampshire
- 1369. Dover, City of, New Hampshire
- 1370. Merrimack, County of, New Hampshire
- 1371. Atlantic City, City of, New Jersey
- 1372. Atlantic, County of, New Jersey
- 1373. Belleville, Township of, New Jersey
- 1374. Bergen, County of, New Jersey
- 1375. Berkeley, Township of, New Jersey
- 1376. Bloomfield, Township of, New Jersey
- 1377. Brick, Township of, New Jersey
- 1378. Bridgewater, Township of, New Jersey
- 1379. Camden, City of, New Jersey
- 1380. Camden, County of, New Jersey
- 1381. Cape May, County of, New Jersey
- 1382. Cherry Hill, Township of, New Jersey
- 1383. Cumberland, County of, New Jersey
- 1384. Deptford, Township of, New Jersey
- 1385. East Brunswick, Township of, New Jersey
- 1386. East Orange, City of, New Jersey
- 1387. Edison, Township of, New Jersey
- 1388. Egg Harbor, Township of, New Jersey
- 1389. Essex, County of, New Jersey
- 1390. Evesham, Township of, New Jersey
- 1391. Ewing, Township of, New Jersey
- 1392. Fair Lawn, Borough of, New Jersey
- 1393. Fort Lee, Borough of, New Jersey
- 1394. Franklin, Township of, New Jersey
- 1395. Freehold, Township of, New Jersey
- 1396. Galloway, Township of, New Jersey
- 1397. Garfield, City of, New Jersey
- 1398. Gloucester, County of, New Jersey
- 1399. Gloucester, Township of, New Jersey
- 1400. Hackensack, City of, New Jersey
- 1401. Hamilton, Township of, New Jersey
- 1402. Hillsborough, Township of, New Jersey
- 1403. Hoboken, City of, New Jersey
- 1404. Howell, Township of, New Jersey
- 1405. Irvington, Township of, New Jersey
- 1406. Jackson, Township of, New Jersey
- 1407. Jersey City, City of, New Jersey
- 1408. Kearny, Town of, New Jersey
- 1409. Lakewood, Township of, New Jersey
- 1410. Lawrence, Township of, New Jersey
- 1411. Linden, City of, New Jersey
- 1412. Livingston, Township of, New Jersey

- 1413. Long Branch, City of, New Jersey
- 1414. Manalapan, Township of, New Jersey
- 1415. Manchester, Township of, New Jersey
- 1416. Marlboro, Township of, New Jersey
- 1417. Mercer, County of, New Jersey
- 1418. Middlesex, County of, New Jersey
- 1419. Middletown, Township of, New Jersey
- 1420. Monmouth, County of, New Jersey
- 1421. Montclair, Township of, New Jersey
- 1422. Morris, County of, New Jersey
- 1423. Mount Laurel, Township of, New Jersey
- 1424. New Brunswick, City of, New Jersey
- 1425. Newark, City of, New Jersey
- 1426. North Bergen, Township of, New Jersey
- 1427. North Brunswick, Township of, New Jersey
- 1428. Old Bridge, Township of, New Jersey
- 1429. Orange, Township of, City of, New Jersey
- 1430. Parsippany-Troy Hills, Township of, New Jersey
- 1431. Passaic, City of, New Jersey
- 1432. Passaic, County of, New Jersey
- 1433. Paterson, City of, New Jersey
- 1434. Pennsauken, Township of, New Jersey
- 1435. Perth Amboy, City of, New Jersey
- 1436. Piscataway, Township of, New Jersey
- 1437. Plainfield, City of, New Jersey
- 1438. Princeton, New Jersey
- 1439. Saddle Brook, Township of, New Jersey
- 1440. Salem, County of, New Jersey
- 1441. Sayreville, Borough of, New Jersey
- 1442. Somerset, County of, New Jersey
- 1443. South Brunswick, Township of, New Jersey
- 1444. Sussex, County of, New Jersey
- 1445. Teaneck, Township of, New Jersey
- 1446. Toms River, Township of, New Jersey
- 1447. Union City, City of, New Jersey
- 1448. Union, County of, New Jersey
- 1449. Union, Township of, New Jersey
- 1450. Warren, County of, New Jersey
- 1451. Washington, Township of, New Jersey
- 1452. Wayne, Township of, New Jersey
- 1453. West New York, Town of, New Jersey
- 1454. West Orange, Township of, New Jersey
- 1455. Willingboro, Township of, New Jersey
- 1456. Winslow, Township of, New Jersey
- 1457. Woodbridge, Township of, New Jersey
- 1458. Albany, County of, New York
- 1459. Amherst, Town of, New York
- 1460. Babylon, Town of, New York
- 1461. Bethlehem, Town of, New York
- 1462. Binghamton, City of, New York
- 1463. Brighton, Town of, New York
- 1464. Bronx, County of, New York
- 1465. Carmel, Town of, New York
- 1466. Cattaraugus, County of, New York
- 1467. Cayuga, County of, New York
- 1468. Chautauqua, County of, New York
- 1469. Cheektowaga, Town of, New York
- 1470. Chemung, County of, New York
- 1471. Chenango, County of, New York

- 1472. Cicero, Town of, New York
- 1473. Clarence, Town of, New York
- 1474. Clay, Town of, New York
- 1475. Clifton Park, Town of, New York
- 1476. Colonie, Town of, New York
- 1477. Cortlandt, Town of, New York
- 1478. Delaware, County of, New York
- 1479. Eastchester, Town of, New York
- 1480. Essex, County of, New York
- 1481. Freeport, Village of, New York
- 1482. Greece, Town of, New York
- 1483. Greenburgh, Town of, New York
- 1484. Guilderland, Town of, New York
- 1485. Hamburg, Town of, New York
- 1486. Henrietta, Town of, New York
- 1487. Irondequoit, Town of, New York
- 1488. Kings, County of, New York
- 1489. Lancaster, Town of, New York
- 1490. Livingston, County of, New York
- 1491. Madison, County of, New York
- 1492. Manlius, Town of, New York
- 1493. Mount Pleasant, Town of, New York
- 1494. Mount Vernon, City of, New York
- 1495. New Rochelle, City of, New York
- 1496. New York, County of, New York
- 1497. Newburgh, Town of, New York
- 1498. Niagara Falls, City of, New York
- 1499. North Tonawanda, City of, New York
- 1500. Orleans, County of, New York
- 1501. Ossining, Town of, New York
- 1502. Otsego, County of, New York
- 1503. Penfield, Town of, New York
- 1504. Perinton, Town of, New York
- 1505. Putnam, County of, New York
- 1506. Queens, County of, New York
- 1507. Richmond, County of, New York
- 1508. Rockland, County of, New York
- 1509. Rye, Town of, New York
- 1510. Salina, Town of, New York
- 1511. Spring Valley, Village of, New York
- 1512. Stony Point, Town of, New York
- 1513. Tioga, County of, New York
- 1514. Tonawanda, Town of, New York
- 1515. Union, Town of, New York
- 1516. Wappinger, Town of, New York
- 1517. Warren, County of, New York
- 1518. Warwick, Town of, New York
- 1519. Wayne, County of, New York
- 1520. Webster, Town of, New York
- 1521. West Seneca, Town of, New York
- 1522. White Plains, City of, New York
- 1523. Yates, County of, New York
- 1524. Yorktown, Town of, New York
- 1525. Alleghany, County of, North Carolina
- 1526. Apex, Town of, North Carolina
- 1527. Asheville, City of, North Carolina
- 1528. Bertie, County of, North Carolina
- 1529. Burlington, City of, North Carolina
- 1530. Cary, Town of, North Carolina
- 1531. Chapel Hill, Town of, North Carolina
- 1532. Charlotte, City of, North Carolina
- 1533. Chowan, County of, North Carolina
- 1534. Concord, City of, North Carolina
- 1535. Cornelius, Town of, North Carolina
- 1536. Currituck, County of, North Carolina
- 1537. Durham, City of, North Carolina
- 1538. Edgecombe, County of, North Carolina
- 1539. Fuquay-Varina, Town of, North Carolina
- 1540. Garner, Town of, North Carolina
- 1541. Gastonia, City of, North Carolina
- 1542. Goldsboro, City of, North Carolina

- 1543. Greenville, City of, North Carolina
- 1544. Harnett, County of, North Carolina
- 1545. Henderson, County of, North Carolina
- 1546. High Point, City of, North Carolina
- 1547. Hoke, County of, North Carolina
- 1548. Holly Springs, Town of, North Carolina
- 1549. Huntersville, Town of, North Carolina
- 1550. Indian Trail, Town of, North Carolina
- 1551. Jackson, County of, North Carolina
- 1552. Johnston, County of, North Carolina
- 1553. Kannapolis, City of, North Carolina
- 1554. Lee, County of, North Carolina
- 1555. Macon, County of, North Carolina
- 1556. Madison, County of, North Carolina
- 1557. Matthews, Town of, North Carolina
- 1558. Monroe, City of, North Carolina
- 1559. Mooresville, Town of, North Carolina
- 1560. Nash, County of, North Carolina
- 1561. Pender, County of, North Carolina
- 1562. Polk, County of, North Carolina
- 1563. Raleigh, City of, North Carolina
- 1564. Rocky Mount, City of, North Carolina
- 1565. Salisbury, City of, North Carolina
- 1566. Sanford, City of, North Carolina
- 1567. Stanly, County of, North Carolina
- 1568. Stokes, County of, North Carolina
- 1569. Transylvania, County of, North Carolina
- 1570. Union, County of, North Carolina
- 1571. Wake, County of, North Carolina
- 1572. Wake Forest, Town of, North Carolina
- 1573. Warren, County of, North Carolina
- 1574. Washington, County of, North Carolina
- 1575. Wilson, City of, North Carolina
- 1576. Wilson, County of, North Carolina
- 1577. Yadkin, County of, North Carolina
- 1578. Yancey, County of, North Carolina
- 1579. Cass, County of, North Dakota
- 1580. Fargo, City of, North Dakota
- 1581. Grand Forks, City of, North Dakota
- 1582. Minot, City of, North Dakota
- 1583. Morton, County of, North Dakota
- 1584. West Fargo, City of, North Dakota
- 1585. Alliance, City of, Ohio
- 1586. Anderson, Township of, Ohio
- 1587. Athens, Township of, Ohio
- 1588. Austintown, Township of, Ohio
- 1589. Bath, Township of, Ohio
- 1590. Beavercreek, City of, Ohio
- 1591. Beavercreek, Township of, Ohio
- 1592. Boardman, Township of, Ohio
- 1593. Bowling Green, City of, Ohio
- 1594. Brown, County of, Ohio
- 1595. Brunswick, City of, Ohio
- 1596. Canton, City of, Ohio
- 1597. Carroll, County of, Ohio
- 1598. Clark, County of, Ohio
- 1599. Clear Creek, Township of, Ohio
- 1600. Cleveland Heights, City of, Ohio
- 1601. Colerain, Township of, Ohio
- 1602. Columbus, City of, Ohio
- 1603. Concord, Township of, Ohio
- 1604. Deerfield, Township of, Ohio

- 1605. Defiance, County of, Ohio
- 1606. Delaware, City of, Ohio
- 1607. Dublin, City of, Ohio
- 1608. Fairborn, City of, Ohio
- 1609. Fostoria, City of, Ohio
- 1610. Franklin, Township of, Ohio
- 1611. Gahanna, City of, Ohio
- 1612. Green, Township of, Ohio
- 1613. Greene, County of, Ohio
- 1614. Grove City, City of, Ohio
- 1615. Hardin, County of, Ohio
- 1616. Highland, County of, Ohio
- 1617. Hilliard, City of, Ohio
- 1618. Holmes, County of, Ohio
- 1619. Huber Heights, City of, Ohio
- 1620. Kettering, City of, Ohio
- 1621. Lakewood, City of, Ohio
- 1622. Lancaster, City of, Ohio
- 1623. Madison, County of, Ohio
- 1624. Mahoning, County of, Ohio
- 1625. Mansfield, City of, Ohio
- 1626. Marion, City of, Ohio
- 1627. Marion, Township of, Ohio
- 1628. Mason, City of, Ohio
- 1629. Massillon, City of, Ohio
- 1630. Medina, County of, Ohio
- 1631. Mentor, City of, Ohio
- 1632. Miami, County of, Ohio
- 1633. Mifflin, Township of, Ohio
- 1634. Monroe, County of, Ohio
- 1635. Morrow, County of, Ohio
- 1636. Newark, City of, Ohio
- 1637. Norwalk, City of, Ohio
- 1638. Norwich, Township of, Ohio
- 1639. Orange, Township of, Ohio
- 1640. Painesville, Township of, Ohio
- 1641. Perry, County of, Ohio
- 1642. Pickaway, County of, Ohio
- 1643. Plain, Township of, Ohio
- 1644. Preble, County of, Ohio
- 1645. Putnam, County of, Ohio
- 1646. Reynoldsburg, City of, Ohio
- 1647. Richland, County of, Ohio
- 1648. Sandusky, City of, Ohio
- 1649. Springfield, City of, Ohio
- 1650. Sylvania, Township of, Ohio
- 1651. Tuscarawas, County of, Ohio
- 1652. Union, County of, Ohio
- 1653. Union, Township of, Ohio
- 1654. Upper Arlington, City of, Ohio
- 1655. Van Wert, City of, Ohio
- 1656. Vinton, County of, Ohio
- 1657. Violet, Township of, Ohio
- 1658. Warren, County of, Ohio
- 1659. West Chester, Township of, Ohio
- 1660. Westerville, City of, Ohio
- 1661. Westlake, City of, Ohio
- 1662. Wood, County of, Ohio
- 1663. Youngstown, City of, Ohio
- 1664. Stillwater, City of, Oklahoma
- 1665. Albany, City of, Oregon
- 1666. Beaverton, City of, Oregon
- 1667. Bend, City of, Oregon
- 1668. Benton, County of, Oregon
- 1669. Corvallis, City of, Oregon
- 1670. Curry, County of, Oregon
- 1671. Deschutes, County of, Oregon
- 1672. Douglas, County of, Oregon
- 1673. Eugene, City of, Oregon
- 1674. Grants Pass, City of, Oregon
- 1675. Gresham, City of, Oregon
- 1676. Hillsboro, City of, Oregon
- 1677. Keizer, City of, Oregon
- 1678. Klamath, County of, Oregon
- 1679. Lake Oswego, City of, Oregon
- 1680. Lincoln, County of, Oregon
- 1681. Linn, County of, Oregon
- 1682. Malheur, County of, Oregon
- 1683. Marion, County of, Oregon
- 1684. McMinnville, City of, Oregon
- 1685. Medford, City of, Oregon
- 1686. Oregon City, City of, Oregon
- 1687. Polk, County of, Oregon
- 1688. Redmond, City of, Oregon
- 1689. Salem, City of, Oregon
- 1690. Springfield, City of, Oregon
- 1691. Tigard, City of, Oregon
- 1692. Umatilla, County of, Oregon
- 1693. Abington, Township of,  
Pennsylvania
- 1694. Allentown, City of, Pennsylvania
- 1695. Altoona, City of, Pennsylvania



- 1696. Bethel Park, Municipality of, Pennsylvania
- 1697. Bethlehem, City of, Pennsylvania
- 1698. Blair, County of, Pennsylvania
- 1699. Butler, County of, Pennsylvania
- 1700. Centre, County of, Pennsylvania
- 1701. Cheltenham, Township of, Pennsylvania
- 1702. Chester, City of, Pennsylvania
- 1703. Cranberry, Township of, Pennsylvania
- 1704. Crawford, County of, Pennsylvania
- 1705. Cumberland, County of, Pennsylvania
- 1706. Erie, City of, Pennsylvania
- 1707. Falls, Township of, Pennsylvania
- 1708. Hampden, Township of, Pennsylvania
- 1709. Harrisburg, City of, Pennsylvania
- 1710. Haverford, Township of, Pennsylvania
- 1711. Hempfield, Township of, Pennsylvania
- 1712. Huntingdon, County of, Pennsylvania
- 1713. Jefferson, County of, Pennsylvania
- 1714. Kingston, Borough of, Pennsylvania
- 1715. Lancaster, City of, Pennsylvania
- 1716. Lancaster, County of, Pennsylvania
- 1717. Lebanon, County of, Pennsylvania
- 1718. Lower Macungie, Township of, Pennsylvania
- 1719. Lower Merion, Township of, Pennsylvania
- 1720. Lower Paxton, Township of, Pennsylvania
- 1721. Lower Southampton, Township of, Pennsylvania
- 1722. Manheim, Township of, Pennsylvania
- 1723. McKean, County of, Pennsylvania
- 1724. Mifflin, County of, Pennsylvania
- 1725. Millcreek, Township of, Pennsylvania
- 1726. Montgomery, County of, Pennsylvania
- 1727. Mount Lebanon, Township of, Pennsylvania
- 1728. New Castle, City of, Pennsylvania
- 1729. Norristown, Borough of, Pennsylvania
- 1730. North Huntingdon, Township of, Pennsylvania
- 1731. Northampton, Township of, Pennsylvania
- 1732. Penn Hills, Township of, Pennsylvania
- 1733. Perry, County of, Pennsylvania
- 1734. Pittsburgh, City of, Pennsylvania
- 1735. Radnor, Township of, Pennsylvania
- 1736. Reading, City of, Pennsylvania
- 1737. Ridley, Township of, Pennsylvania
- 1738. Ross, Township of, Pennsylvania
- 1739. Scranton, City of, Pennsylvania
- 1740. Snyder, County of, Pennsylvania
- 1741. Somerset, County of, Pennsylvania
- 1742. State College, Borough of, Pennsylvania
- 1743. Susquehanna, County of, Pennsylvania
- 1744. Union, County of, Pennsylvania
- 1745. Upper Darby, Township of, Pennsylvania
- 1746. Upper Merion, Township of, Pennsylvania
- 1747. Venango, County of, Pennsylvania
- 1748. Warren, County of, Pennsylvania
- 1749. Wayne, County of, Pennsylvania
- 1750. York, City of, Pennsylvania
- 1751. York, County of, Pennsylvania

1752. Adjuntas, Municipality of, Puerto Rico
1753. Aguada, Municipality of, Puerto Rico
1754. Aguadilla, Municipality of, Puerto Rico
1755. Arecibo, Municipality of, Puerto Rico
1756. Arroyo, Municipality of, Puerto Rico
1757. Barceloneta, Municipality of, Puerto Rico
1758. Bayamon, Municipality of, Puerto Rico
1759. Bayamón, Municipality of, Puerto Rico
1760. Cabo Rojo, Municipality of, Puerto Rico
1761. Caguas, Municipality of, Puerto Rico
1762. Camuy, Municipality of, Puerto Rico
1763. Carolina, Municipality of, Puerto Rico
1764. Catano, Municipality of, Puerto Rico
1765. Ceiba, Municipality of, Puerto Rico
1766. Cidra, Municipality of, Puerto Rico
1767. Coamo, Municipality of, Puerto Rico
1768. Corozal, Municipality of, Puerto Rico
1769. Dorado, Municipality of, Puerto Rico
1770. Guayama, Municipality of, Puerto Rico
1771. Guaynabo, Municipality of, Puerto Rico
1772. Gurabo, Municipality of, Puerto Rico
1773. Hatillo, Municipality of, Puerto Rico
1774. Humacao, Municipality of, Puerto Rico
1775. Isabela, Municipality of, Puerto Rico
1776. Juana Díaz, Municipality of, Puerto Rico
1777. Las Piedras, Municipality of, Puerto Rico
1778. Manatí, Municipality of, Puerto Rico
1779. Mayagüez, Municipality of, Puerto Rico
1780. Moca, Municipality of, Puerto Rico
1781. Morovis, Municipality of, Puerto Rico
1782. Ponce, Municipality of, Puerto Rico
1783. San Germán, Municipality of, Puerto Rico
1784. San Lorenzo, Municipality of, Puerto Rico
1785. San Sebastián, Municipality of, Puerto Rico
1786. Toa Alta, Municipality of, Puerto Rico
1787. Toa Baja, Municipality of, Puerto Rico
1788. Trujillo Alto, Municipality of, Puerto Rico
1789. Vega Baja, Municipality of, Puerto Rico
1790. Villalba, Municipality of, Puerto Rico
1791. Yauco, Municipality of, Puerto Rico
1792. Barrington, Town of, Rhode Island
1793. Bristol, Town of, Rhode Island
1794. Providence, City of, Rhode Island
1795. Warren, Town of, Rhode Island
1796. Aiken, City of, South Carolina
1797. Columbia, City of, South Carolina
1798. Darlington, County of, South Carolina
1799. Florence, City of, South Carolina

1800. Goose Creek, City of, South Carolina
1801. Greenville, City of, South Carolina
1802. Greer, City of, South Carolina
1803. Hilton Head Island, Town of, South Carolina
1804. Mount Pleasant, Town of, South Carolina
1805. Rock Hill, City of, South Carolina
1806. Spartanburg, City of, South Carolina
1807. Sumter, City of, South Carolina
1808. Brookings, County of, South Dakota
1809. Brown, County of, South Dakota
1810. Lincoln, County of, South Dakota
1811. Minnehaha, County of, South Dakota
1812. Rapid City, City of, South Dakota
1813. Sioux Falls, City of, South Dakota
1814. Bartlett, City of, Tennessee
1815. Brentwood, City of, Tennessee
1816. Cannon, County of, Tennessee
1817. Carter, County of, Tennessee
1818. Chattanooga, City of, Tennessee
1819. Cheatham, County of, Tennessee
1820. Cleveland, City of, Tennessee
1821. Coffee, County of, Tennessee
1822. Collierville, Town of, Tennessee
1823. Crockett, County of, Tennessee
1824. Davidson, County of, Tennessee
1825. Decatur, County of, Tennessee
1826. Dickson, County of, Tennessee
1827. Dyer, County of, Tennessee
1828. Fayette, County of, Tennessee
1829. Franklin, City of, Tennessee
1830. Gallatin, City of, Tennessee
1831. Germantown, City of, Tennessee
1832. Gibson, County of, Tennessee
1833. Hamblen, County of, Tennessee
1834. Hendersonville, City of, Tennessee
1835. Henry, County of, Tennessee
1836. Jackson, City of, Tennessee
1837. Johnson City, City of, Tennessee
1838. Johnson, County of, Tennessee
1839. Kingsport, City of, Tennessee
1840. La Vergne, City of, Tennessee
1841. Lawrence, County of, Tennessee
1842. Lawrenceburg, City of, Tennessee
1843. Lebanon, City of, Tennessee
1844. Lincoln, County of, Tennessee
1845. Maryville, City of, Tennessee
1846. Maury, County of, Tennessee
1847. McMinnville, City of, Tennessee
1848. Memphis, City of, Tennessee
1849. Morgan, County of, Tennessee
1850. Morristown, City of, Tennessee
1851. Mount Juliet, City of, Tennessee
1852. Nashville-Davidson Metropolitan Government, Tennessee
1853. Obion, County of, Tennessee
1854. Overton, County of, Tennessee
1855. Robertson, County of, Tennessee
1856. Shelby, County of, Tennessee
1857. Smyrna, Town of, Tennessee
1858. Sullivan, County of, Tennessee
1859. Sumner, County of, Tennessee
1860. Tipton, County of, Tennessee
1861. Weakley, County of, Tennessee
1862. Wilson, County of, Tennessee
1863. Abilene, City of, Texas
1864. Allen, City of, Texas
1865. Amarillo, City of, Texas
1866. Anderson, County of, Texas
1867. Arlington, City of, Texas
1868. Atascosa, County of, Texas
1869. Austin, City of, Texas
1870. Austin, County of, Texas
1871. Bastrop, County of, Texas
1872. Baytown, City of, Texas
1873. Beaumont, City of, Texas
1874. Bedford, City of, Texas
1875. Bee, County of, Texas
1876. Bell, County of, Texas

- 1877. Blanco, County of, Texas
- 1878. Bowie, County of, Texas
- 1879. Brazoria, County of, Texas
- 1880. Brown, County of, Texas
- 1881. Brownsville, City of, Texas
- 1882. Bryan, City of, Texas
- 1883. Burleson, City of, Texas
- 1884. Burnet, County of, Texas
- 1885. Caldwell, County of, Texas
- 1886. Calhoun, County of, Texas
- 1887. Cameron, County of, Texas
- 1888. Camp, County of, Texas
- 1889. Carrollton, City of, Texas
- 1890. Cass, County of, Texas
- 1891. Cedar Hill, City of, Texas
- 1892. Cedar Park, City of, Texas
- 1893. Chambers, County of, Texas
- 1894. Cibolo, City of, Texas
- 1895. Cleburne, City of, Texas
- 1896. College Station, City of, Texas
- 1897. Collin, County of, Texas
- 1898. Colorado, County of, Texas
- 1899. Comal, County of, Texas
- 1900. Conroe, City of, Texas
- 1901. Cooke, County of, Texas
- 1902. Coppell, City of, Texas
- 1903. Copperas Cove, City of, Texas
- 1904. Corpus Christi, City of, Texas
- 1905. Dallas, City of, Texas
- 1906. Deer Park, City of, Texas
- 1907. Del Rio, City of, Texas
- 1908. Denton, City of, Texas
- 1909. Denton, County of, Texas
- 1910. DeSoto, City of, Texas
- 1911. Duncanville, City of, Texas
- 1912. Ector, County of, Texas
- 1913. Edinburg, City of, Texas
- 1914. El Paso, City of, Texas
- 1915. El Paso, County of, Texas
- 1916. Erath, County of, Texas
- 1917. Eules, City of, Texas
- 1918. Falls, County of, Texas
- 1919. Fannin, County of, Texas
- 1920. Farmers Branch, City of, Texas
- 1921. Flower Mound, Town of, Texas
- 1922. Fort Bend, County of, Texas
- 1923. Fort Worth, City of, Texas
- 1924. Franklin, County of, Texas
- 1925. Friendswood, City of, Texas
- 1926. Frisco, City of, Texas
- 1927. Galveston, City of, Texas
- 1928. Galveston, County of, Texas
- 1929. Garland, City of, Texas
- 1930. Georgetown, City of, Texas
- 1931. Grand Prairie, City of, Texas
- 1932. Grapevine, City of, Texas
- 1933. Grayson, County of, Texas
- 1934. Gregg, County of, Texas
- 1935. Guadalupe, County of, Texas
- 1936. Hale, County of, Texas
- 1937. Haltom City, City of, Texas
- 1938. Hardin, County of, Texas
- 1939. Harker Heights, City of, Texas
- 1940. Harlingen, City of, Texas
- 1941. Harris, County of, Texas
- 1942. Harrison, County of, Texas
- 1943. Hays, County of, Texas
- 1944. Hidalgo, County of, Texas
- 1945. Hill, County of, Texas
- 1946. Hood, County of, Texas
- 1947. Hopkins, County of, Texas
- 1948. Houston, City of, Texas
- 1949. Houston, County of, Texas
- 1950. Howard, County of, Texas
- 1951. Hunt, County of, Texas
- 1952. Huntsville, City of, Texas
- 1953. Hurst, City of, Texas
- 1954. Irving, City of, Texas
- 1955. Jasper, County of, Texas
- 1956. Jefferson, County of, Texas
- 1957. Keller, City of, Texas
- 1958. Kerr, County of, Texas
- 1959. Killeen, City of, Texas
- 1960. Kyle, City of, Texas
- 1961. La Porte, City of, Texas
- 1962. Lancaster, City of, Texas
- 1963. League City, City of, Texas
- 1964. Leander, City of, Texas
- 1965. Leon, County of, Texas
- 1966. Leon Valley, City of, Texas
- 1967. Lewisville, City of, Texas
- 1968. Liberty, County of, Texas

- 1969. Limestone, County of, Texas
- 1970. Little Elm, City of, Texas
- 1971. Longview, City of, Texas
- 1972. Lubbock, City of, Texas
- 1973. Lubbock, County of, Texas
- 1974. Lufkin, City of, Texas
- 1975. Madison, County of, Texas
- 1976. Mansfield, City of, Texas
- 1977. Matagorda, County of, Texas
- 1978. McAllen, City of, Texas
- 1979. McKinney, City of, Texas
- 1980. Medina, County of, Texas
- 1981. Mesquite, City of, Texas
- 1982. Midland, City of, Texas
- 1983. Midland, County of, Texas
- 1984. Midlothian, City of, Texas
- 1985. Milam, County of, Texas
- 1986. Mission, City of, Texas
- 1987. Missouri City, City of, Texas
- 1988. Morris, County of, Texas
- 1989. Nacogdoches, City of, Texas
- 1990. Nacogdoches, County of, Texas
- 1991. Navarro, County of, Texas
- 1992. New Braunfels, City of, Texas
- 1993. Newton, County of, Texas
- 1994. North Richland Hills, City of, Texas
- 1995. Nueces, County of, Texas
- 1996. Odessa, City of, Texas
- 1997. Orange, County of, Texas
- 1998. Panola, County of, Texas
- 1999. Parker, County of, Texas
- 2000. Pasadena, City of, Texas
- 2001. Pearland, City of, Texas
- 2002. Pflugerville, City of, Texas
- 2003. Pharr, City of, Texas
- 2004. Plano, City of, Texas
- 2005. Port Arthur, City of, Texas
- 2006. Potter, County of, Texas
- 2007. Randall, County of, Texas
- 2008. Red River, County of, Texas
- 2009. Richardson, City of, Texas
- 2010. Robertson, County of, Texas
- 2011. Rockwall, City of, Texas
- 2012. Rosenberg, City of, Texas
- 2013. Round Rock, City of, Texas
- 2014. Rowlett, City of, Texas
- 2015. San Angelo, City of, Texas
- 2016. San Juan, City of, Texas
- 2017. San Marcos, City of, Texas
- 2018. San Patricio, County of, Texas
- 2019. Schertz, City of, Texas
- 2020. Shelby, County of, Texas
- 2021. Sherman, City of, Texas
- 2022. Socorro, City of, Texas
- 2023. Southlake, City of, Texas
- 2024. Starr, County of, Texas
- 2025. Sugar Land, City of, Texas
- 2026. Taylor, County of, Texas
- 2027. Temple, City of, Texas
- 2028. Texarkana, City of, Texas
- 2029. Texas City, City of, Texas
- 2030. The Colony, City of, Texas
- 2031. Tom Green, County of, Texas
- 2032. Travis, County of, Texas
- 2033. Trinity, County of, Texas
- 2034. Tyler, City of, Texas
- 2035. Uvalde, County of, Texas
- 2036. Val Verde, County of, Texas
- 2037. Van Zandt, County of, Texas
- 2038. Victoria, City of, Texas
- 2039. Victoria, County of, Texas
- 2040. Waco, City of, Texas
- 2041. Walker, County of, Texas
- 2042. Waller, County of, Texas
- 2043. Washington, County of, Texas
- 2044. Waxahachie, City of, Texas
- 2045. Weatherford, City of, Texas
- 2046. Weslaco, City of, Texas
- 2047. Wharton, County of, Texas
- 2048. Wichita Falls, City of, Texas
- 2049. Wilson, County of, Texas
- 2050. Wise, County of, Texas
- 2051. Wood, County of, Texas
- 2052. Wylie, City of, Texas
- 2053. American Fork, City of, Utah
- 2054. Bountiful, City of, Utah
- 2055. Box Elder, County of, Utah
- 2056. Carbon, County of, Utah
- 2057. Cedar City, City of, Utah
- 2058. Clearfield, City of, Utah

- 2059. Cottonwood Heights, City of, Utah
- 2060. Davis, County of, Utah
- 2061. Draper, City of, Utah
- 2062. Eagle Mountain, City of, Utah
- 2063. Herriman, City of, Utah
- 2064. Holladay, City of, Utah
- 2065. Iron, County of, Utah
- 2066. Kaysville, City of, Utah
- 2067. Kearns, Metro Township of, Utah
- 2068. Layton, City of, Utah
- 2069. Lehi, City of, Utah
- 2070. Logan, City of, Utah
- 2071. Midvale, City of, Utah
- 2072. Millard, County of, Utah
- 2073. Millcreek, City of, Utah
- 2074. Murray, City of, Utah
- 2075. Ogden, City of, Utah
- 2076. Orem, City of, Utah
- 2077. Pleasant Grove, City of, Utah
- 2078. Provo, City of, Utah
- 2079. Riverton, City of, Utah
- 2080. Roy, City of, Utah
- 2081. Salt Lake City, City of, Utah
- 2082. San Juan, County of, Utah
- 2083. Sandy, City of, Utah
- 2084. Sanpete, County of, Utah
- 2085. Saratoga Springs, City of, Utah
- 2086. South Jordan, City of, Utah
- 2087. Spanish Fork, City of, Utah
- 2088. Springville, City of, Utah
- 2089. St. George, City of, Utah
- 2090. Syracuse, City of, Utah
- 2091. Taylorsville, City of, Utah
- 2092. Tooele, City of, Utah
- 2093. West Jordan, City of, Utah
- 2094. West Valley City, City of, Utah
- 2095. Addison, County of, Vermont
- 2096. Bennington, County of, Vermont
- 2097. Brattleboro, Town of, Vermont
- 2098. Burlington, City of, Vermont
- 2099. Chittenden, County of, Vermont
- 2100. Franklin, County of, Vermont
- 2101. Rutland, County of, Vermont
- 2102. Washington, County of, Vermont
- 2103. Windham, County of, Vermont
- 2104. Windsor, County of, Vermont
- 2105. Albemarle, County of, Virginia
- 2106. Augusta, County of, Virginia
- 2107. Bedford, County of, Virginia
- 2108. Blacksburg, Town of, Virginia
- 2109. Buchanan, County of, Virginia
- 2110. Campbell, County of, Virginia
- 2111. Caroline, County of, Virginia
- 2112. Carroll, County of, Virginia
- 2113. Charlottesville, City of, Virginia
- 2114. Gloucester, County of, Virginia
- 2115. Grayson, County of, Virginia
- 2116. Hampton, City of, Virginia
- 2117. Hanover, County of, Virginia
- 2118. Harrisonburg, City of, Virginia
- 2119. James City, County of, Virginia
- 2120. Leesburg, Town of, Virginia
- 2121. Lynchburg, City of, Virginia
- 2122. Manassas, City of, Virginia
- 2123. Martinsville, City of, Virginia
- 2124. Newport News, City of, Virginia
- 2125. Orange, County of, Virginia
- 2126. Petersburg, City of, Virginia
- 2127. Portsmouth, City of, Virginia
- 2128. Rockingham, County of, Virginia
- 2129. Spotsylvania, County of, Virginia
- 2130. Suffolk, City of, Virginia
- 2131. York, County of, Virginia
- 2132. Anacortes, City of, Washington
- 2133. Clark, County of, Washington
- 2134. Kent, City of, Washington
- 2135. King, County of, Washington
- 2136. Kirkland, City of, Washington
- 2137. Kittitas, County of, Washington
- 2138. Lakewood, City of, Washington
- 2139. Lincoln, County of, Washington
- 2140. Mount Vernon, City of, Washington
- 2141. Olympia, City of, Washington
- 2142. San Juan, County of, Washington
- 2143. Seattle, City of, Washington
- 2144. Sedro-Woolley, City of, Washington
- 2145. Skagit, County of, Washington

- 2146. Spokane, City of, Washington
- 2147. Spokane, County of, Washington
- 2148. Thurston, County of, Washington
- 2149. Vancouver, City of, Washington
- 2150. Whatcom, County of,  
Washington
- 2151. Appleton, City of, Wisconsin
- 2152. Beloit, City of, Wisconsin
- 2153. Brookfield, City of, Wisconsin
- 2154. Cudahy, City of, Wisconsin
- 2155. Eau Claire, City of, Wisconsin
- 2156. Fitchburg, City of, Wisconsin
- 2157. Fond du Lac, City of, Wisconsin
- 2158. Franklin, City of, Wisconsin
- 2159. Green Bay, City of, Wisconsin
- 2160. Greenfield, City of, Wisconsin
- 2161. Janesville, City of, Wisconsin
- 2162. La Crosse, City of, Wisconsin
- 2163. Madison, City of, Wisconsin
- 2164. Manitowoc, City of, Wisconsin
- 2165. Marinette, City of, Wisconsin
- 2166. Menomonee Falls, Village of,  
Wisconsin
- 2167. Mount Pleasant, Village of,  
Wisconsin
- 2168. New Berlin, City of, Wisconsin
- 2169. Oak Creek, City of, Wisconsin
- 2170. Oshkosh, City of, Wisconsin
- 2171. Polk, County of, Wisconsin
- 2172. Racine, City of, Wisconsin
- 2173. Sheboygan, City of, Wisconsin
- 2174. South Milwaukee, City of,  
Wisconsin
- 2175. Sun Prairie, City of, Wisconsin
- 2176. Superior, City of, Wisconsin
- 2177. Waukesha, City of, Wisconsin
- 2178. Wausau, City of, Wisconsin
- 2179. Wauwatosa, City of, Wisconsin
- 2180. West Allis, City of, Wisconsin
- 2181. West Bend, City of, Wisconsin
- 2182. Albany, County of, Wyoming
- 2183. Campbell, County of, Wyoming
- 2184. Fremont, County of, Wyoming
- 2185. Gillette, City of, Wyoming
- 2186. Laramie, City of, Wyoming
- 2187. Laramie, County of, Wyoming
- 2188. Natrona, County of, Wyoming
- 2189. Sheridan, County of, Wyoming

**EXHIBIT X**

**Governor’s Release of Opioid-Related Claims Pursuant to the Walmart Settlement Agreement**

I, [NAME], Governor of the [Commonwealth]/[State]/[Territory] of [Commonwealth]/[State]/[Territory], hereby authorize Attorney General [NAME] to settle and release, to the maximum extent of my power as Governor, all Released Claims of (1) all of [Commonwealth]/[State]/[Territory]’s past and present executive departments, agencies, divisions, boards, commissions and instrumentalities with regulatory authority to enforce state and federal controlled substances acts and (2) all of [Commonwealth]/[State]/[Territory]’s past and present executive departments, agencies, divisions, boards, commissions and instrumentalities that have the authority to bring Claims related to Alleged Harms and/or Covered Conduct seeking money (including abatement and/or remediation) or revocation or suspension of a pharmaceutical distribution or dispensing license. The foregoing authorization is given in connection with Section X.G of that certain settlement agreement dated as of November [●], 2022 setting forth the terms of settlement between and among Walmart Inc., on the one hand, and certain Settling States and certain Participating Subdivisions on the other hand. This release is intended to be a “release from a State’s Governor” as contemplated in such section. Capitalized terms used herein and defined in such settlement agreement have the meanings given to them in such settlement agreement.

\_\_\_\_\_  
Governor of the [Commonwealth]/[State]/[Territory] of [Commonwealth]/[State]/[Territory]

Date: \_\_\_\_\_



**EXHIBIT K**

**Subdivision Participation Form**

Governmental Entity:	State:
Authorized Official:	
Address 1:	
Address 2:	
City, State, Zip:	
Phone:	
Email:	

The governmental entity identified above (“Governmental Entity”), in order to obtain and in consideration for the benefits provided to the Governmental Entity pursuant to the Settlement Agreement dated November 14, 2022 (“Walmart Settlement”), and acting through the undersigned authorized official, hereby elects to participate in the Walmart Settlement, release all Released Claims against all Released Entities, and agrees as follows.

1. The Governmental Entity is aware of and has reviewed the Walmart Settlement, understands that all terms in this Election and Release have the meanings defined therein, and agrees that by this Election, the Governmental Entity elects to participate in the Walmart Settlement and become a Participating Subdivision as provided therein.
2. The Governmental Entity shall promptly, and in any event within 14 days of the Effective Date and prior to the filing of the Consent Judgment, dismiss with prejudice any Released Claims that it has filed. With respect to any Released Claims pending in In re National Prescription Opiate Litigation, MDL No. 2804, the Governmental Entity authorizes the Plaintiffs’ Executive Committee to execute and file on behalf of the Governmental Entity a Stipulation of Dismissal With Prejudice substantially in the form found at <https://nationalopiodsettlement.com/>.
3. The Governmental Entity agrees to the terms of the Walmart Settlement pertaining to Subdivisions as defined therein.
4. By agreeing to the terms of the Walmart Settlement and becoming a Releasor, the Governmental Entity is entitled to the benefits provided therein, including, if applicable, monetary payments beginning after the Effective Date.
5. The Governmental Entity agrees to use any monies it receives through the Walmart Settlement solely for the purposes provided therein.



6. The Governmental Entity submits to the jurisdiction of the court in the Governmental Entity's state where the Consent Judgment is filed for purposes limited to that court's role as provided in, and for resolving disputes to the extent provided in, the Walmart Settlement.
7. The Governmental Entity has the right to enforce the Walmart Settlement as provided therein.
8. The Governmental Entity, as a Participating Subdivision, hereby becomes a Releasor for all purposes in the Walmart Settlement, including but not limited to all provisions of Section X (Release), and along with all departments, agencies, divisions, boards, commissions, districts, instrumentalities of any kind and attorneys, and any person in their official capacity elected or appointed to serve any of the foregoing and any agency, person, or other entity claiming by or through any of the foregoing, and any other entity identified in the definition of Releasor, provides for a release to the fullest extent of its authority. As a Releasor, the Governmental Entity hereby absolutely, unconditionally, and irrevocably covenants not to bring, file, or claim, or to cause, assist or permit to be brought, filed, or claimed, or to otherwise seek to establish liability for any Released Claims against any Released Entity in any forum whatsoever. The releases provided for in the Walmart Settlement are intended by the Parties to be broad and shall be interpreted so as to give the Released Entities the broadest possible bar against any liability relating in any way to Released Claims and extend to the full extent of the power of the Governmental Entity to release claims. The Walmart Settlement shall be a complete bar to any Released Claim.
9. In connection with the releases provided for in the Walmart Settlement, each Governmental Entity expressly waives, releases, and forever discharges any and all provisions, rights, and benefits conferred by any law of any state or territory of the United States or other jurisdiction, or principle of common law, which is similar, comparable, or equivalent to § 1542 of the California Civil Code, which reads:

**General Release; extent.** A general release does not extend to claims that the creditor or releasing party does not know or suspect to exist in his or her favor at the time of executing the release that, if known by him or her, would have materially affected his or her settlement with the debtor or released party.

A Releasor may hereafter discover facts other than or different from those which it knows, believes, or assumes to be true with respect to the Released Claims, but each Governmental Entity hereby expressly waives and fully, finally, and forever settles, releases and discharges, upon the Effective Date, any and all Released Claims that may exist as of such date but which Releasors do not know or suspect to exist, whether through ignorance, oversight, error, negligence or through no fault whatsoever, and which, if known, would materially affect the Governmental Entities' decision to participate in the Walmart Settlement.

10. Nothing herein is intended to modify in any way the terms of the Walmart Settlement, to which Governmental Entity hereby agrees. To the extent this Election and Release is interpreted differently from the Walmart Settlement in any respect, the Walmart Settlement controls.



I have all necessary power and authorization to execute this Election and Release on behalf of the Governmental Entity.

Signature: \_\_\_\_\_

Name: \_\_\_\_\_

Title: \_\_\_\_\_

Date: \_\_\_\_\_



**WALMART GLOBAL SETTLEMENT  
OPIOID LITIGATION SETTLEMENT CALCULATOR**

<b>GLOBAL SETTLEMENT</b>	<b>\$ 2,393,794,118.64</b>
<b>NEVADA RECOVERY ( 1.3464414888%)</b>	<b>\$ 32,231,037.17</b>
<b>LEAD LITIGATOR COSTS ESTIMATE</b>	
<b>FEDERAL GOVERNMENT CMS MEDICAID COSTS (22.52%)</b>	
<b>ALLOCATION AMOUNT ESTIMATE</b>	<b>\$ 32,231,037.17</b>

<b>GOVERNMENT ENTITY</b>	<b>GROSS ALLOCATION</b>	<b>GROSS ATTORNEY FEES</b>	<b>NET ALLOCATION</b>
STATE OF NEVADA	\$ 14,136,532.91		\$ 14,136,532.91
CARSON CITY	\$ 328,343.01		\$ 328,343.01
CHURCHILL COUNTY	\$ 126,897.70		\$ 126,897.70
CLARK COUNTY	\$ 12,109,711.28		\$ 12,109,711.28
DOUGLAS COUNTY	\$ 300,395.23		\$ 300,395.23
ELKO COUNTY	\$ 195,886.49		\$ 195,886.49
ESMERALDA COUNTY	\$ 8,998.24		\$ 8,998.24
EUREKA COUNTY	\$ 18,702.00		\$ 18,702.00
HUMBOLDT COUNTY	\$ 184,432.30		\$ 184,432.30
LANDER COUNTY	\$ 65,636.71		\$ 65,636.71
LINCOLN COUNTY	\$ 42,943.40		\$ 42,943.40
LYON COUNTY	\$ 284,470.89		\$ 284,470.89
MINERAL COUNTY	\$ 108,439.10		\$ 108,439.10
NYE COUNTY	\$ 289,816.81		\$ 289,816.81
PERSHING COUNTY	\$ 65,583.51		\$ 65,583.51
STOREY COUNTY	\$ 22,869.80		\$ 22,869.80
WASHOE COUNTY	\$ 1,649,123.87		\$ 1,649,123.87
WHITE PINE COUNTY	\$ 189,242.76		\$ 189,242.76
BOULDER CITY	\$ 26,755.63		\$ 26,755.63
ELY CITY	\$ 1,197.36		\$ 1,197.36
FERNLEY CITY	\$ 2,614.78		\$ 2,614.78
HENDERSON CITY	\$ 416,547.14		\$ 416,547.14
LAS VEGAS CITY	\$ 854,186.73		\$ 854,186.73
MESQUITE CITY	\$ 26,509.71		\$ 26,509.71
NORTH LAS VEGAS CITY	\$ 438,952.17		\$ 438,952.17
RENO CITY	\$ 245,413.29		\$ 245,413.29
SPARKS CITY	\$ 76,960.07		\$ 76,960.07
WEST WENDOVER CITY	\$ 10,205.59		\$ 10,205.59
CENTRAL LYON FIRE PROTECTION DISTRICT	\$ 2,730.87		\$ 2,730.87
NORTH LYON FIRE PROTECTION DISTRICT	\$ 937.82		\$ 937.82

**TOTAL: \$ 32,231,037.17 \$ - \$ 32,231,037.17**



## STAFF REPORT

**Report To:** Board of Supervisors

**Meeting Date:** March 2, 2023

**Staff Contact:** Lyndsey Boyer, Open Space Manager and Gregg Berggren, Trails Coordinator

**Agenda Title:** For Possible Action: Discussion and possible action regarding the proposed acceptance of the Southern Nevada Public Lands Management Act ("SNPLMA") Round 18 grants and cooperative agreements from the U.S. Department of Interior - Bureau of Land Management, in the amount of \$1,883,875 with a \$50,000 cash match from Q18 - Quality of Life funds for the Buzzy's Ranch Water Rights and Wetland Enhancement Project and \$2,403,250 for the Carson River Trails Phase III - Prison Hill West Project, both effective November 17, 2022 through November 16, 2027. (Lyndsey Boyer, lboyer@carson.org; Gregg Berggren, gberggren@carson.org)

Staff Summary: Nominations for the Buzzy's Ranch Water Rights and Wetland Enhancement Project and Carson River Trails Phase III - Prison Hill West Project were both approved by the Secretary of Interior. The City recently received Notices of Award and Cooperative Agreements for both projects. The award for the Carson River Trails Phase III - Prison Hill West Project does not include a cash match but the Parks, Recreation & Open Space Department would commit \$17,500 in staff time towards the project.

**Agenda Action:** Formal Action / Motion

**Time Requested:** 5 minutes

---

### **Proposed Motion**

I move to authorize the acceptance of the grants and cooperative agreements as presented.

### **Board's Strategic Goal**

N/A

### **Previous Action**

September 3, 2020 (Item 12.B): The Board of Supervisors moved 5-0-0 to authorize the submittal of both grant applications as discussed.

### **Background/Issues & Analysis**

On September 14, 2020, two nominations were submitted for Round 18 SNPLMA funding within the category of Parks, Trails and Natural Areas ("PTNA"). Both nominations were approved, and they were signed by the Secretary of Interior on October 7, 2021. The City recently received Notices of Award and Cooperative Agreements for both projects which are detailed below.

**Buzzy's Ranch Water Rights and Wetland Enhancement Project:**

This award of \$1,883,875 will enable the City to acquire the quantity of stream water rights (no more than 694.35-acre-feet annually) necessary to sustain beneficial use of the approximately 148.48 acres of wetland and wet meadow habitat on Buzzy's Ranch Open Space. Acquisition of the water rights will enhance an existing natural area (wetland and wet meadow) by providing a permanent and dedicated water source to

sustain the habitat and preserve the aesthetic value of the property through scenic viewsheds for recreational and public enjoyment.

There is a \$50,000 cash match from the Q18 Quality of Life funding for this project. This funding will be allocated from the match that was previously budgeted for the Carson River Trails Project Phase II. Final costs for that project were lower than expected, so the \$50,000 match was not required and can therefore be utilized elsewhere.

This project supports CCMC Chapter 13.06, Open Space, by helping to sustain natural and scenic resources and the long-term quality of life in Carson City,

---

**Carson River Trails, Phase III - Prison Hill West:**

This award of \$2,403,250 will enable the City to design and construct a non-motorized multi-use trail approximately 2.5 miles in length along the west side of Prison Hill and make improvements to the existing Koontz Lane Trailhead. Trailhead improvements will include regrading the access road and improve drainage, regrading and reshaping the parking area and installing an ADA accessible single-vault toilet and picnic table with shade structure. This project will continue an ongoing effort to create a network of trails that connect neighborhoods to parks and open space lands in the Carson River/Prison Hill area; enhance recreational opportunities for families and those with mobility challenges; and improve visitor safety while maintaining the conservation values of these important properties. Previous phases I and II were both SNPLMA funded projects that included the construction of the Eagle Creek Bridge, and construction of three miles of shared-use trails on Prison Hill and along the Carson River.

Additionally, \$17,500 of non-cash match has been allocated to the project as in-kind contribution of staff time, though it was not a requirement of the grant.

This project supports the Carson City Master Plan, Guiding Principle 12, which says, "Carson City is committed to shared use of most trail corridors..." and goes on to say, "The City will also seek to provide access to all feasible portions of the pathway system and open space areas for persons with disabilities." The project also supports trail connectivity goals identified in Carson City's Unified Pathways Master Plan, the Charrette Summary: Creating a Community Vision - Silver Saddle Ranch and the Carson River, and the Eagle Valley Trail Committee Community Trail Inventory, Review, Evaluation and User Needs Assessment Report.

**Attachments:**

- 1 – Notice of Award and Cooperative Agreement for the Buzzy's Ranch Water Rights Acquisition and Wetlands Enhancement Project.
- 2 – Notice of Award and Cooperative Agreement for the Carson River Trails Phase III - Prison Hill West Project.

**Applicable Statute, Code, Policy, Rule or Regulation**

Carson City's Grant Policy; CCMC Chapter 13.06 Open Space Carson; City's Master Plan Carson City's Unified Pathways Master Plan

**Financial Information**

**Is there a fiscal impact?** Yes

**If yes, account name/number:** Quality of Life - Open Space - 2545047-500460

Quality of Life - Salaries and Benefits - 2545047-500101 through 2545047-500271

**Is it currently budgeted?** Yes

**Explanation of Fiscal Impact:** Buzzy's Ranch Water Rights and Wetlands Enhancement Project: \$50,000 match from Q18.

Carson River Trails, Phase III - Prison Hill West: \$17,500 in-kind match (staff time).

**Alternatives**

Do not authorize acceptance of the grants and the cooperative agreements.

**Attachments:**

[L23AC00020-00 Notice of Award.pdf](#)

[L23AC00007 MOD 1 NOTICE OF AWARD.pdf](#)

**Board Action Taken:**

Motion: _____	1) _____	Aye/Nay
	2) _____	_____
		_____
		_____
		_____

\_\_\_\_\_  
(Vote Recorded By)

1. DATE ISSUED MM/DD/YYYY 11/17/2022

1a. SUPERSEDES AWARD NOTICE dated 11/17/2022 except that any additions or restrictions previously imposed remain in effect unless specifically rescinded

2. CFDA NO. 15.235 - Southern Nevada Public Land Management

3. ASSISTANCE TYPE Cooperative Agreement

4. GRANT NO. L23AC00020-00  
Originating MCA #

5. TYPE OF AWARD Other

4a. FAIN L23AC00020

5a. ACTION TYPE New

6. PROJECT PERIOD MM/DD/YYYY  
From 11/17/2022 Through 11/16/2027

7. BUDGET PERIOD MM/DD/YYYY  
From 11/17/2022 Through 11/16/2027

**NOTICE OF AWARD**



AUTHORIZATION (Legislation/Regulations)  
Southern Nevada Public Land Management Act of 1998, 31 U.S.C. 6901, PL 105-263

8. TITLE OF PROJECT (OR PROGRAM)  
SNPLMA Project CR05, Priority 18-19, Buzzy's Ranch Water Rights and Wetland Enhancement

9a. GRANTEE NAME AND ADDRESS  
CITY OF CARSON CITY  
201 N Carson St  
Carson City, NV, 89701-4594

9b. GRANTEE PROJECT DIRECTOR  
Lyndsey Boyer  
201 N Carson St Ste 5  
Carson City, NV, 89701-4289  
Phone: 775-283-7341

10a. GRANTEE AUTHORIZING OFFICIAL  
Lyndsey Boyer  
201 N Carson St Ste 5  
Carson City, NV, 89701-4289  
Phone: 775-283-7341

10b. FEDERAL PROJECT OFFICER  
Ms. Michelle Eis  
1340 Financial  
Reno, NV, 89520  
Phone: 775-861-6418

**ALL AMOUNTS ARE SHOWN IN USD**

11. APPROVED BUDGET (Excludes Direct Assistance)	
I Financial Assistance from the Federal Awarding Agency Only	
II Total project costs including grant funds and all other financial participation	
a. Salaries and Wages	0.00
b. Fringe Benefits	0.00
c. Total Personnel Costs	0.00
d. Equipment	0.00
e. Supplies	24,000.00
f. Travel	0.00
g. Construction	0.00
h. Other	1,735,875.00
i. Contractual	174,000.00
<b>j. TOTAL DIRECT COSTS</b>	<b>\$ 1,933,875.00</b>
k. INDIRECT COSTS	\$ 0.00
<b>l. TOTAL APPROVED BUDGET</b>	<b>\$ 1,933,875.00</b>
m. Federal Share	\$ 1,883,875.00
n. Non-Federal Share	\$ 50,000.00

12. AWARD COMPUTATION	
a. Amount of Federal Financial Assistance (from item 11m)	\$ 1,883,875.00
b. Less Unobligated Balance From Prior Budget Periods	\$ 0.00
c. Less Cumulative Prior Award(s) This Budget Period	\$ 0.00
<b>d. AMOUNT OF FINANCIAL ASSISTANCE THIS ACTION</b>	<b>\$ 1,883,875.00</b>
<b>13. Total Federal Funds Awarded to Date for Project Period</b>	<b>\$ 1,883,875.00</b>

14. RECOMMENDED FUTURE SUPPORT (Subject to the availability of funds and satisfactory progress of the project):			
YEAR	TOTAL DIRECT COSTS	YEAR	TOTAL DIRECT COSTS
a. 2	\$	d. 5	\$
b. 3	\$	e. 6	\$
c. 4	\$	f. 7	\$

15. PROGRAM INCOME SHALL BE USED IN ACCORD WITH ONE OF THE FOLLOWING ALTERNATIVES:

- a. DEDUCTION
- b. ADDITIONAL COSTS
- c. MATCHING
- d. OTHER RESEARCH (Add / Deduct Option)
- e. OTHER (See REMARKS)

a

16. THIS AWARD IS BASED ON AN APPLICATION SUBMITTED TO, AND AS APPROVED BY, THE FEDERAL AWARING AGENCY ON THE ABOVE TITLED PROJECT AND IS SUBJECT TO THE TERMS AND CONDITIONS INCORPORATED EITHER DIRECTLY OR BY REFERENCE IN THE FOLLOWING:

- a. The grant program legislation
- b. The grant program regulations.
- c. This award notice including terms and conditions, if any, noted below under REMARKS.
- d. Federal administrative requirements, cost principles and audit requirements applicable to this grant.

In the event there are conflicting or otherwise inconsistent policies applicable to the grant, the above order of precedence shall prevail. Acceptance of the grant terms and conditions is acknowledged by the grantee when funds are drawn or otherwise obtained from the grant payment system.

REMARKS (Other Terms and Conditions Attached -  Yes  No)  
See next page

GRANTS MANAGEMENT OFFICIAL:  
Amy Marshall, Grants Management Officer  
222 WEST 7TH AVENUE  
13  
ANCHORAGE, AK, 99513-7504  
Phone: (907) 271-2816

17. VENDOR CODE	0070163745	18a. UEI DTBPJMA2QFC8	18b. DUNS 073787152	19. CONG. DIST.	02	
LINE#	FINANCIAL ACCT	AMT OF FIN ASST	START DATE	END DATE	TAS ACCT	PO LINE DESCRIPTION
1	0051029475-00010	\$1,883,875.00	11/17/2022	11/16/2027	5232	SNPLMA Rd 18 PTNA Proj #CR05 (18-19)



# NOTICE OF AWARD (Continuation Sheet)

PAGE 2 of 3	DATE ISSUED 11/17/2022
GRANT NO. L23AC00020-00	

REMARKS:

Notice of Intent (NOI) Announcement Number: L-LSNPLMA-22-001  
Application: L-LSNPLMA-22-001  
SNPLMA Project CR05, Priority 18-19, Buzzy's Ranch Water Rights and Wetland Enhancement  
Carson City

Total Amount of Federal Funding: \$1,883,875.00  
Required Cost Sharing/Matching: None required; however the recipient is contributing \$50,000 in cost share.  
Indirect Cost Rate: NONE

Required Periodic Status Reporting: Annual Reporting is required for the SF425 Financial Reports and Performance Reports. Submit reports To: GrantSolutions.gov

Refer to Attachment No. 1 for Award Terms and Conditions  
Authority: Southern Nevada Public Land Management Act of 1998, 31 U.S.C. 6901, PL 105-263

This cooperative agreement is made and entered into by the Department of the Interior (DOI), Bureau of Land Management (BLM), Nevada State Office (NVSO), and Carson City, the recipient, for the purpose of transferring something of value to the recipient to carry out a public purpose of support or stimulation authorized by a law of the United States.

Acceptance of a Federal Financial Assistance award from the DOI carries with it the responsibility to be aware of and comply with the terms and conditions of award. Acceptance is defined as the start of work, drawing down funds, or accepting the award via electronic means.

BLM substantial involvement by the BLM Program Officer (PO); Refer to the Terms and Conditions, Attachment No.1, paragraph 2B.

Prior to making any drawdown in ASAP; See 3. ASAP Draw Down Requirements for SNPLMA Projects and copy the following people:  
Amy Lee, BLM Business Services Division National Operations Center (NOC): aelee@blm.gov  
Gary Thompson, Finance Manager, BLM Business Services Division National Operations Center (NOC): garythomps@blm.gov  
Michelle Leiber, Program Officer (PO), SNPLMA Division: mleiber@blm.gov

NOTICE OF AWARD (Continuation Sheet)

PAGE 3 of 3	DATE ISSUED 11/17/2022
GRANT NO. L23AC00020-00	

Federal Financial Report Cycle			
Reporting Period Start Date	Reporting Period End Date	Reporting Type	Reporting Period Due Date
11/17/2022	09/30/2023	Annual	12/29/2023
10/01/2023	09/30/2024	Annual	12/29/2024
10/01/2024	09/30/2025	Annual	12/29/2025
10/01/2025	09/30/2026	Annual	12/29/2026
10/01/2026	09/30/2027	Annual	12/29/2027
10/01/2027	11/16/2027	Final	03/15/2028

Performance Progress Report Cycle			
Reporting Period Start Date	Reporting Period End Date	Reporting Type	Reporting Period Due Date
11/17/2022	09/30/2023	Annual	12/29/2023
10/01/2023	09/30/2024	Annual	12/29/2024
10/01/2024	09/30/2025	Annual	12/29/2025
10/01/2025	09/30/2026	Annual	12/29/2026
10/01/2026	09/30/2027	Annual	12/29/2027
10/01/2027	11/16/2027	Final	03/15/2028

# AWARD ATTACHMENTS

CITY OF CARSON CITY

L23AC00020-00

---

1. L23AC00020 Attachment 1

## 1. COOPERATIVE AGREEMENT OBJECTIVES:

### A. Objective(s):

Carson City will acquire the quantity of stream water rights (no more than 694.35-acre-feet annually) necessary to sustain beneficial use of the ±148.48 acres of wetland and wet meadow habitat on Carson City's property (Buzzy's Ranch) located adjacent to the Carson River in Carson City, Nevada. Acquisition of the water rights will enhance an existing natural area (wetland and wet meadow) on the property by providing a permanent and dedicated water source to sustain the habitat and preserve the aesthetic value of the property through scenic viewsheds for recreational and public enjoyment.

### B. Public Benefit(s):

1. Improve the quality of life for all public in urban and rural communities by enhancing recreational opportunities that connect people with the outdoor environment.
2. Promoting project connectivity and sustainability between new or existing recreation opportunities and other community facilities accommodations, and services (e.g., community centers, schools, or mass transit).
3. Provide recreational opportunities and improve access to those opportunities on Federal, State, local and regional government lands by increasing the availability and quality of public recreation.
4. Protect or improve the integrity of environmental, cultural, historical, educational, community, recreational, and open space resources to enhance the quality of the human experience and by increasing the community's understanding and appreciation of the natural outdoor environment.

### C. Federal Award Performance Goals:

Acquire the quantity of stream water rights (no more than 694.35-AFA) necessary to sustain beneficial use of the wetland and wet meadow habitat on Carson City's Buzzy's Ranch property.

## 2. PROPOSED WORK

- A. The Recipient's Nomination Package dated 09/14/2020, as submitted through the SNPLMA Round 18 nomination process, entitled "*Buzzy's Ranch Water Rights and Wetland Enhancement*," and assigned SNPLMA project number CR05, priority number 18-19, is accepted by the BLM and incorporated herein, as part of this agreement. The recipient will also develop and maintain a project workplan, as accepted by the BLM, in the SNPLMA Management and Reporting Tool or "SMART" online database.

Additional documents incorporated by reference: Recipient GrantSolutions application number LSNPLMA-2022-000037, dated 03/28/2022 to include Standard Form (SF) 424 Application for Federal Assistance, SF-424A (Budget Information - Non-Construction Programs), Budget Detail, signed Certification Regarding Lobbying - Certification for Contracts, Grants, Loans, or Cooperative Agreement.

Additionally, the recipient agrees to:

- Adhere to the policies and procedures identified in the effective SNPLMA Implementation Agreement.
- Adhere to the Recipient procurement plan and federal procurement standards under 2 CFR § 200.318. Ensure federal, state, and local government permits are obtained, if required.
- Initiate, complete, and provide proof of documentation compliance with federal environmental and cultural resource laws, e.g., National Environmental Policy Act (NEPA), Endangered Species Act (ESA), Migratory Bird Treaty Act, and the National Historic Preservation Act (NHPA), as applicable.
  - The Grant Management Officer (GMO) and Program Officer (PO) will provide additional information on the NEPA and NHPA compliance in a separate document.
  - The recipient must provide to the GMO and PO documentation that confirms compliance is satisfactorily completed before the recipient will be allowed to proceed project implementation. When proof of compliance has been provided, the PO will respond in writing (email or letter) to the recipient (and e-copy the GMO) a “SNPLMA notice to proceed” to allow the recipient to proceed with project implementation.
- Include the following conspicuously placed disclosure for materials generated for display or distribution (brochures, flyers, public planning documents, public scoping meetings, videos, etc.): “This project was funded due to the Southern Nevada Public Land Management Act, which authorized the sale of BLM-administered federal lands within a designated boundary in the Las Vegas Valley and required proceeds to be used on projects to fund federal, state and local projects that benefit communities and public lands.”
- Provide project signage conspicuously placed, which states: “This project was funded due to the Southern Nevada Public Land Management Act, which authorized the sale of BLM-administered federal lands within a designated boundary in the Las Vegas Valley and required proceeds to be used on projects to fund federal, state, and local projects that benefit communities and public lands.”

B. In addition, the BLM will:

- Review and accept the recipient’s project work plan before funds are authorized for expenditure.
- Approve the recipient to transition from planning activities to implementation of the project objectives following the acceptance of prerequisite environmental, cultural/historic, and/or land-use compliance and documentation requirements.
- Closely monitor the project’s quarterly status information for scope, time, and amount and its compliance with the SNPLMA Implementation Agreement.
- Conduct a pre-work, progress, and final site visits.
- Manage the change management process, including the request, decision, and post-decision actions involving the project’s scope, time, and amount.

- Ensure completion of the project's deliverable(s), accurate reporting of accomplishments, and public accomplishment information in annual reports and databases.
- C. The recipient will also be responsible for significant developments, i.e., events which may occur between the scheduled performance reporting dates that have significant impact upon the supported activity. In such cases, the recipient must inform the PO as soon as the following types of conditions become known:
1. Problems, delays, or adverse conditions which will materially impair the ability to meet the objective of the Federal award. This disclosure must include a statement of the action taken, or contemplated, and any assistance needed to resolve the situation.
  2. Favorable developments which enable meeting time schedules and objectives sooner or at less cost than anticipated or producing more or different beneficial results than originally planned.

### **3. TERM OF AGREEMENT**

- A. The term, or period of performance, of this agreement shall become effective as of the date shown on the signed award cover page and may remain in effect for a maximum of five (5) years.

The BLM will consider continued support of the project upon; (a) the recipient showing progress satisfactory to the BLM toward program goals and the determination by the BLM that continuation of the program would be in the best interests of the Government, (b) project is still in line with management's top priorities, and/or (c) the availability of funds.

B. Budget and Program Revisions

1. Recipients must submit in writing to the BLM's PO any request for budget or program revision in accordance with 2 CFR §200.308.
2. Modifications:
  - Requests to modify this Agreement's scope, time, or amount will require advance approval of the authorized SNPLMA official. A request for modification must be made to the SNPLMA Division using the modification request form in the SNPLMA Implementation Agreement, Part Two, Appendix L Project Modification Form.
  - Request to modify this Agreement's scope, time or amount shall be submitted no later than 120 calendar days before the current Agreement end date.
  - Requests for extensions for the reimbursement of funds will be considered on a case-by-case basis.
  - Requests to modify this Agreement's scope, time, or amount that receive approval from the SNPLMA Division via a decision memo signed by the SNPLMA

authorized representative must complete additional steps/documentation to modify this Agreement through Grant Solutions and receive a modified agreement executed by the GMO.

- This Agreement may be modified by written agreement signed by both the Recipient's Authorized Representative and the GMO. Administrative changes (i.e., GMO or PO name change, etc.) that do not change the work plan, scope, time, or amount, may be unilaterally signed by the GMO.
- All other changes shall be made by bilateral modification to the Agreement. No oral statement made by any person, or written statement by any person other than the GMO, shall be allowed in any manner or degree to modify or otherwise effect the terms of the Agreement.

C. Termination. This agreement may be terminated in accordance with the provisions of 2 CFR, Subpart D, §200.340 Termination and the procedures outlined in the SNPLMA Implementation Agreement.

#### **4. FINANCIAL SUPPORT AND PAYMENT METHOD**

A. Funding. The Recipient agrees not to exceed the total amount of available incremental funding. The Government is not obligated to reimburse the Recipient for the Recipient's expenditure of amounts in excess of the total available incremental funding nor is the Recipient obligated to continue performance beyond the incrementally funded amount. The obligation of funds for future incremental payments shall be subject to the availability of funds.

Funds obligated but not expended by the Recipient in a fiscal year may be carried forward and expended in subsequent fiscal years consistent with the period of performance in this Agreement.

B. Maximum Obligations. The Recipient agrees not to exceed the total amount of available incremental funding. The Government is not obligated to reimburse the Recipient for the Recipient's expenditure of amounts in excess of the total available incremental funding nor is the Recipient obligated to continue performance beyond the incrementally funded amount. The obligation of funds for future incremental payments shall be subject to the availability of funds.

The total obligations, including modifications, represent the amount for which the BLM will be responsible under the terms of this agreement. The BLM shall not be responsible to pay for, nor shall the recipient be responsible to perform, any effort that will require the expenditure of Federal funds above the current obligated amount.

C. Reimbursable Costs and Limitations. The recipient shall not incur costs or obligate funds for any purpose pertaining to operation of the program or activities beyond the expiration date stated in the agreement. The BLM's financial participation is limited. The BLM will only fund up to its share of those amounts requested in the project proposal and as are subsequently approved and funded in the agreement. The recipient shall not be obligated to continue performance under the agreement or to incur costs in excess of the costs set

forth in the proposal and subsequent agreement. However, if the Recipient chooses to expend funds in excess of the approved project budget, the Recipient will be responsible to fund the excess without funding participation by the Bureau.

#### D. Cost Sharing and Matching

Cost sharing for this agreement shall be in accordance with 2 CFR, Subpart D, §200.306, Cost sharing or matching.

1. There is no cost share or match legislatively required for this award.
2. If the recipient voluntarily included cost sharing or matching in the approved nomination, then the recipient will be required to document the cost-share or match in accordance with the 2 CFR, Subpart D, §200.306, Cost sharing or matching.

#### E. Program Income

Program income generated under this award can be as follows:

1. Program income generated for this agreement shall be in accordance with **2 CFR, Subpart D, §200.306(e)(3) Cost Sharing or Matching** - Program income may be used to meet the cost sharing or matching requirement of the Federal award. The amount of the Federal award remains the same. Program income generated through the performance of this project must be reported on SF 425, Federal Financial Report (see section **6. PERFORMANCE, FINANCIAL, AND OTHER REPORTING**).

#### F. Indirect Costs

1. The Recipient has never had a federally approved negotiated indirect rate, and as the BLM is the cognizant agency, the Recipient has requested and received approval from the BLM for reimbursement under this agreement at the de minimis rate shown on the award cover sheet under "Indirect Cost Rate." This rate is to be applied to the agreement's base modified total direct costs (MTDC). MTDC consist of all salaries and wages, fringe benefits, materials and supplies, services, travel, and subgrants and subcontracts up to the first \$25,000 of each subgrant or subcontract (regardless of the period covered by the subgrant or subcontract). Equipment, capital expenditures, charges for patient care, rental costs, and the portion of subgrants or subcontracts in excess of \$25,000 shall be excluded from TDC. Participant support costs shall generally be excluded from MTDC.

#### G. Payment by Reimbursement

1. Payment will be made by draw-down reimbursement through the Department of the Treasury, Automated Standard Application for Payment (ASAP) System. See following website: <http://www.fms.treas.gov/asap> Treasury Circular 1075 (31 CFR §205) requires that drawdowns to a recipient organization shall be limited to the



- minimum amounts needed and shall be timed to be in accordance with the actual, immediate cash requirements of the recipient organization in carrying out the purposes of the approved program or project. The timing and amount of cash advances shall be as close as is administratively feasible to the actual disbursements by the recipient organization for direct program or project costs and the proportionate share of any allowable indirect costs.
2. Funds that are available from repayments to and interest earned on a revolving fund, program income, rebates, refunds, contract settlements, audit recoveries, credits, discounts, and interest earned on any of those funds, must be disbursed before requesting additional cash payments.
  3. ASAP Draw Down Requirements for SNPLMA Projects:
    - Prior to requesting an ASAP drawdown, the Recipient shall send an email to the appropriate program specific PO (aka SNPLMA Program Manager) and e-copy the BLM representatives identified below, with the amount of funding to be drawn down **at least 3 days before** requesting the ASAP draw down. If the ASAP draw down request contains multiple projects by the Recipient, the Recipient shall provide the PO a list of the projects to draw down funds separated by agreement number and amount.
      - Michelle Leiber, [mleiber@blm.gov](mailto:mleiber@blm.gov) - PO/SNPLMA Program Manager for the Parks, Trails, and Natural Areas (PTNA) and Multi-Species Habitat Conservation Plan (MSHCP) categories; **and e-copy**
      - Amy Lee, [aelee@blm.gov](mailto:aelee@blm.gov) – SNPLMA Sr. Accountant, BLM National Operations Center (NOC);
      - Gary Thompson - [gthomps@blm.gov](mailto:gthomps@blm.gov) – SNPLMA Accountant, BLM NOC; and
      - Robert Wandel, [rwandel@blm.gov](mailto:rwandel@blm.gov) – SNPLMA Assistant District Manager, BLM SNPLMA Division.
    - An ASAP draw down will be made only in the amount(s) necessary to meet the current reimbursement needs. The GMO and PO may request additional information to support the drawdown of funding. The drawdown of funding may not commence until the additional documentation or justification is received. The PO will confirm the Recipient may complete the draw down via email.
    - An ASAP draw down can occur as frequently as needed. The Recipient shall make every effort to stay within the quarterly projections submitted to the PO through the SMART database, however, if the recipient needs to draw down more funding than previously projected, the Recipient will provide justification via email to the PO prior to initiating the ASAP draw down request.
    - The Recipient must retain documentation to support all ASAP draw downs, organized by draw down. Failure to retain the appropriate level of

documentation to support the draw down may result in a determination that the reimbursement, or certain costs within the reimbursement, is/are not allowable or allocable to the federal award.

- Approval to complete a drawdown of funding does not imply the expenditures are allowable or allocable. The GMO and/or the PO will complete progress and final financial file reviews to determine the allowable and allocable costs to the federal award. Expenditures that are determined to be unallowable or unallocable after disbursement will be deducted from the next draw down request.
- At the completion or termination of the Agreement, unused funding shall be returned through ASAP to the BLM. This must be completed within the 120-day payment period following the performance period end date.

#### H. Payment Review

If a recipient has a history of poor performance, financial instability, uses a management system not meeting standards prescribed by the Uniform Administrative Requirements, has not conformed to the terms and conditions of the award, and/or is not otherwise responsible in safeguarding Federal funds, they may be determined to be "high risk" and be placed on Agency Review. Agency Review limits a recipient's access to funds by requiring that all draw-down requests reviewed and approved prior to their being released. Recipients on agency review must submit a completed SF-270 Request for Advance Payment or Reimbursement for each payment requested along with a detailed explanation of how the costs correspond to the approved budget categories as listed on their Application for Federal Assistance SF-424A Budget Information and their Detailed Budget Breakdown or Challenge Cost Share Program Commitment Document, whichever is applicable. Being put on Agency Review does not relieve the recipient of required financial or performance reporting requirements.

#### I. System for Award Management (SAM, [www.SAM.gov](http://www.SAM.gov))

Recipients of Federal financial assistance must maintain current registration with the System for Award Management (SAM, [www.SAM.gov](http://www.SAM.gov)). Failure to maintain registration can impact access to funds and future obligations under this agreement and any other financial assistance or procurement award the recipient may have with the Federal government.

### 5. PERFORMANCE & FINANCIAL MONITORING

- A. In accordance with 2 CFR §200.328 Financial Reporting and §200.329 Monitoring and Reporting Program Performance, the recipient is responsible for oversight, monitoring, and reporting of its activities under Federal awards to assure compliance with applicable Federal requirements and that performance expectations are being achieved. The BLM's monitoring of the recipient's activities may include review of the award file including discussions with the recipient regarding reporting, award activities, and project status (desk reviews), analysis of financial and performance reports, and discussions of specific

issues related to project implementation, observation of project activity, and review of planned versus actual progress (site visits). The BLM has the right to inspect and evaluate the work performed or being performed under this agreement, and the premises where the work is being performed, at all reasonable times and in a manner that will not unduly delay the work. If the BLM performs inspection or evaluation on the premises of the recipient or a sub-recipient, the recipient shall furnish and shall require sub-recipients to furnish all reasonable facilities and assistance for the safe and convenient performance of these duties.

1. BLM programmatic monitoring addresses the content and substance of the program. It is a qualitative review to determine performance, innovation, and contributions to the field. The BLM may make site visits as warranted by program needs. In addition, the BLM has the right of timely and unrestricted access to any books, documents, papers, or other records of the recipient's that are pertinent to the award, in order to make audits, examinations, excerpts, transcripts, and copies of such documents. This right also includes timely and reasonable access to recipient personnel for the purpose of interviews and discussions related to such documents.
2. BLM financial monitoring ensures compliance with financial guidelines and general accounting practices. On-site or internal financial reviews are conducted to determine if: (1) award recipients are properly accounting for the receipt and expenditures of federal funds; (2) expenditures are in compliance with federal requirements and award special conditions; and (3) proper documentation on financial monitoring activities is prepared, maintained, and distributed as appropriate.

## 6. PERFORMANCE, FINANCIAL, AND OTHER REPORTING

Periodic financial, performance, and (if applicable) youth employment status reporting is a condition of this financial assistance award. Submission of reports is required whether or not any work has been attempted and/or any funds have been drawn down or expended. Failure to comply with the reporting requirements included in this agreement may be considered a material non-compliance with the terms and conditions of the award. Non-compliance may result in withholding of future payments, suspension or termination of the agreement, recovery of funds paid under the agreement, and withholding of future awards. The periodic status reporting required under this agreement is as follows.

**NOTE: Financial and Performance will be on a yearly reporting cycle for both Financial and Performance Progress Reporting is identified in the Notice of Award.**

### A. Federal Financial Reports

1. Recipients of Federal financial assistance are required to submit periodic financial reports which document the financial status of their awards. The Federal Financial Report (FFR) or SF-425 and SF-425A. Expenditures and/or income may be reported either on a cash or accrual basis, whichever method is normally used by the recipient. Submitted SF-425 reports must be signed by an authorized official of the recipient

certifying that the information complete, accurate, consistent with the recipient's accounting system, and that all expenditures and obligations are for the purposes set forth in the agreement. The SF-425 represents a claim to the Federal government, filing a false claim may result in civil or criminal penalties. Blank SF-425 forms with instructions are available on the Grants.gov web site, URL: <http://www.grants.gov/web/grants/forms.html>.

**B. Performance Reports**

1. Recipients of Federal financial assistance are required to submit periodic performance reports prepared in accordance with 2 CFR, Subpart D, §200.329 Monitoring and Reporting Program Performance. There is no standard form, however performance reports should always relate to the performance goals and objectives identified in Section 1. of this agreement. Performance reports must be submitted in a narrative summary to include, but not limited to, the following:

- Completed established goals, work in progress, future work, the percentage of work completed (based on Section 1 of this document).
- The reasons why established goals and objectives were not met or problems which may impact the ability to complete work on time with recommendations on their resolution, if appropriate.
- Prediction of future activities and how they will be accomplished.
- Where the accomplishments of the Federal award can be quantified, a computation of the cost (for example, related to units of accomplishment) may be required if that information will be useful. Where performance trend data and analysis would be informative to the BLM program the Federal awarding agency should include this as a performance reporting requirement.
- Additional pertinent information including, when appropriate, analysis and explanation of cost overruns or high unit costs.
- Reports are to be submitted electronically within the GrantSolutions system under reporting.

2. Although the Recipient may not be required to report quarterly to the GMO on the FFR or SF-425, the Recipient must submit quarterly financial status reports in the SMART online database. The SMART online database collects status from the previous quarter and funding for the future quarter, as detailed in the table below:

Current Federal Fiscal Year (FY) Quarter	SMART Opens	SMART Closes	Quarterly Status Progress Reporting for:	ASAP Requests and Expended/Obligated for:
Q1	October 1	October 31	Q4 Previous FY (Jul-Sep)	Q2 Current FY (Jan-Mar)
Q2	January 1	January 31	Q1 Current FY (Oct-Dec)	Q3 Current FY (Apr-Jun)

Q3	April 1	April 30	Q2 Current FY (Jan-Mar)	Q4 Current FY (Jul-Sep)
Q4	July 1	July 31	Q3 Current FY (Apr-Jun)	Q1 Following FY (Oct-Dec)

The Recipient will send a transmittal letter to the SNPLMA Division, signed by the Recipient’s authorized representative, certifying the amount of projected funding, in total and per project (as necessary), being requested for draw down in the following quarter, and project compliance with the policies, procedures, and guidelines in the current SNPLMA Implementation Agreement.

3. In addition to the annual performance report required by the 2 CFR §200.328, the Recipient shall submit an annual report in the SMART online database. The annual report in SMART is a summary of the previous year’s activities. At the end of the project, the annual report serves as the final report. The final report is a summary of all major activities and accomplishments over the term of the Agreement and includes the appropriate SNPLMA performance measures.

The Recipient will send a transmittal letter to the SNPLMA Division, signed by the Recipient’s authorized representative, certifying the progress on the project in compliance with the policies, procedures, and guidelines in the current SNPLMA Implementation Agreement. This transmittal letter can be combined with the transmittal letter for financial reporting required in the previous section.

**C. Property Reporting**

1. SF-428 Tangible Personal Property Report is also required under the terms and conditions of this cooperative agreement. Tangible personal property means property of any kind, except real property, that has physical existence. It includes equipment and supplies. It does not include copyrights, patents, or securities. Property may be provided by the awarding agency or acquired by the recipient with award funds. Federally owned property consists of items that were furnished by the Federal government.

**Reporting Period Dates**

**Submit Reports By**

Award Start Date *through* September 30, 2023 .....December 31, 2023\*

\*If Federally Owned Property, report required annually. Any property acquired under this agreement; report required every two years thereafter for the life of the agreement.

**D. Real Property Reporting**

1. Recipients of SNPLMA funding are expected to maintain the real property acquired, constructed, or created, in the same condition or better in perpetuity, unless or until disposition instructions for the real property are issued by the GMO to the recipient.

---

The Recipient is responsible for submitting a report on the status of real property in accordance with 2 CFR, Subpart D, §200.330 Reporting on real property.

2. The Recipient shall submit to the GMO and PO a report on real property annually for the first 3 years following completion of the project, and then every 5 years thereafter.

## **7. LIABILITY, INSURANCE, AND INDEMNIFICATION**

A. Liability. The BLM assumes no liability for any actions or activities conducted under this agreement except to the extent that recourse or remedies are provided by Congress under the Federal Tort Claims Act, 28 USC 2671.

B. Indemnification. The recipient hereby agrees:

1. To indemnify the federal government, Bureau of Land Management (BLM), from any act or omission of the recipient, its officers, employees, or (members, participants, agents, representatives, agents as appropriate) (1) against third party claims for damages arising from one or more activities carried out in connection with this financial assistance agreement and (2) for damage or loss to government property resulting from such an activity, to the extent the laws of the State where the recipient is located permit. This obligation shall survive the termination of this agreement.
2. To pay the United States the full value for all damage to the lands or other property of the United States caused by the recipient, its officers, employees, or (members, participants, agents, representatives, agents as appropriate).
3. To provide workers' compensation protection to the recipient's officers, employees, and representatives.
4. To cooperate with the BLM in the investigation and defense of any claims that may be filed with the BLM arising out of the activities of the recipient, its agents, and employees.
5. In the event of damage to or destruction of the buildings and facilities assigned for the use of the recipient in whole or in part by any cause whatsoever, nothing herein contained shall be deemed to require the BLM to replace or repair the buildings or facilities. If the BLM determines in writing, after consultation with the recipient that damage to the buildings or portions thereof renders such buildings unsuitable for continued use by the recipient, the BLM shall assume sole control over such buildings or portions thereof. If the buildings or facilities rendered unsuitable for use are essential for conducting operations authorized under this agreement, then failure to substitute and assign other facilities acceptable to the recipient will constitute termination of this agreement by the BLM.

C. Flow-down. For the purposes of this clause, "recipient" includes such subrecipients, contractors, or subcontractors as, in the judgment of the recipient and subject to the

---

Government's determination of sufficiency, have sufficient resources and/or maintain adequate and appropriate insurance to achieve the purposes of this clause.

- D. Identified Activities. All activities carried out in connection with this financial assistance agreement.

## **8. BLM PROPERTY STANDARDS**

- A. Government-furnished property (GFP), such as tools and equipment, furnished by the BLM to the recipient shall be used for official purposes only and shall be subject to the terms of the agreement. Tools and equipment shall be returned in the same condition received except for normal wear and tear in project use. Any BLM property used, or other property acquired under this agreement, including intangible property such as copyrights and patents, shall be governed by the property management provisions of 2 CFR, Subpart D, §200.311 to §200.316, Property Standards.
- E. Insurance Coverage: The non-Federal entity must, at a minimum, provide the equivalent insurance coverage for real property and equipment acquired or improved with Federal funds as provided to property owned by the non-Federal entity. Refer to 2 CFR, Subpart D §200.310.
- F. Intangible Property.
1. Title to intangible property (see §200.315 Intangible property) acquired under a Federal award vests upon acquisition in the non-Federal entity. The non-Federal entity must use that property for the originally authorized purpose and must not encumber the property without approval of the Federal awarding agency. When no longer needed for the originally authorized purpose, disposition of the intangible property must occur in accordance with the provisions in §200.313 Equipment paragraph (e).
  2. The non-Federal entity may copyright any work that is subject to copyright and was developed, or for which ownership was acquired, under a Federal award. The Federal awarding agency reserves a royalty-free, nonexclusive, and irrevocable right to reproduce, publish, or otherwise use the work for Federal purposes, and to authorize others to do so.
  3. The non-Federal entity is subject to applicable regulations governing patents and inventions, including Governmentwide regulations issued by the Department of Commerce at 37 CFR Part 401, "Rights to Inventions Made by Nonprofit Organizations and Small Business Firms Under Government Awards, Contracts and Cooperative Agreements."
  4. The Federal government has the right to: (a) Obtain, reproduce, publish, or otherwise use the data produced under a Federal award; and (b) Authorize others to receive, reproduce, publish, or otherwise use such data for Federal purposes.

- G. Recipient staff will be required to complete a BLM-approved Defensive Driving Course if driving a Government-owned vehicle (GOV).
- H. Recipient staff will be required to complete a BLM-approved Four-wheel ATV safety and training program if using Government-furnished ATVs.
- F. Recipient staff will be required to complete a BLM-approved safety and training program if using Government-furnished power equipment, such as chainsaws, woodchippers, etc. The recipient will be responsible for meeting all protective equipment requirements if using Government-furnished equipment.

## 9. KEY OFFICIALS

The key officials on this agreement are listed on the award cover page(s) and are considered to be essential to ensure maximum coordination and communication between the parties and the work being performed. Upon written notice, either party may designate an alternate to act in the place of their designated key official.

## 10. GENERAL TERMS AND CONDITIONS

- A. See the Bureau of Land Management's "[Financial Assistance Award Terms and Conditions](#)" for the administrative and national policy requirements applicable to BLM awards.
- B. [Appendix XII to Part 200—Award Term and Condition for Recipient Integrity and Performance Matters](#)
- C. Program Legislation and/or Regulations:
  - 1. Scientific integrity is vital to Department of the Interior (DOI) activities under which scientific research, data, summaries, syntheses, interpretations, presentations, and/or publications are developed and used. Failure to uphold the highest degree of scientific integrity will result not only in potentially flawed scientific results, interpretations, and applications but will damage DOI's reputation and ability to uphold the public's trust. All work performed must comply with the DOI Scientific Integrity Policy posted to <http://www.doi.gov>, or its equivalent as provided by their organization or State law. For more information go to URL: <https://www.doi.gov/scientificintegrity>.
  - 2. Opposition to Any Legislation. In accordance with the Department of the Interior, Environment, and Related Agencies Act, 2006, Title IV, Section 402, no part of any appropriation contained in this Act shall be available for any activity or the publication or distribution of literature that in any way tends to promote public support or opposition to any legislative proposal on which Congressional action is not complete other than to communicate to Members of Congress as described in 18 U.S.C. 1913.
  - 3. Prohibition on Issuing Financial Assistance Awards to Entities that Require Certain Internal Confidentiality Agreements.



Section 743 of Division E, Title VII of the Consolidated and Further Continuing Resolution Appropriations Act of 2015 (Pub. L. 113-235) prohibits the use of funds appropriated or otherwise made available under that or any other Act for grants or cooperative agreements to an entity that requires employees or contractors of such entity seeking to report fraud, waste, or abuse to sign internal confidentiality agreements or statements prohibiting or otherwise restricting such employees or contractors from lawfully reporting such waste, fraud, or abuse to a designated investigative or law enforcement representative of a federal department or agency authorized to receive such information.

Recipients must not require their employees or contractors seeking to report fraud, waste, or abuse to sign internal confidentiality agreements or statements prohibiting or otherwise restricting such employees or contractors from lawfully reporting such waste, fraud, or abuse to a designated investigative or law enforcement representative of a federal department or agency authorized to receive such information.

Recipients must notify their employees or contractors that existing internal confidentiality agreements covered by this condition are no longer in effect.

4. Order of Precedence. Any inconsistency in this agreement shall be resolved by giving precedence in the following order: (a) Any national policy requirements and administrative management standards; (b) 2 CFR. Part 200; (c) requirements of the applicable OMB Circulars and Treasury regulations; (d) special terms and conditions; (e) all agreement sections, documents, exhibits, and attachments; and (f) the recipient's project proposal.

- I. 2 CFR §1402.315 Availability of data

- (a) All data, methodology, factual inputs, models, analyses, technical information, reports, conclusions, valuation products or other scientific assessments in any medium or form, including textual, numerical, graphic, cartographic, narrative, or audiovisual, resulting from a financial assistance agreement is available for use by the Department of the Interior, including being available in a manner that is sufficient for independent verification.
- (b) The Federal Government has the right to:
  - (1) Obtain, reproduce, publish, or otherwise use the data, methodology, factual inputs, models, analyses, technical information, reports, conclusions, or other scientific assessments, produced under a Federal award; and
  - (2) Authorize others to receive, reproduce, publish, or otherwise use such data, methodology, factual inputs, models, analyses, technical information, reports, conclusions, or other scientific assessments, for Federal purposes, including to allow for meaningful third-party evaluation.

---

## 11. SPECIAL TERMS AND CONDITIONS

- A. Deposit of Publications. In addition to any requirements listed in the Project Management Plan, two (2) copies of each applicable publication produced under this agreement shall be sent to the Natural Resources Library with a transmittal that identifies the sender and the publication, and states that the publication is intended for deposit in the Natural Resources Library. Publications shall be sent to the following address:

U.S. Department of the Interior  
Natural Resources Library  
Interior Service Center  
Gifts and Exchanges Section  
1849 C Street, N.W.  
Washington, D.C. 20240

- B. Buy America Domestic Procurement Preference: As required by Section 70914 of the Bipartisan Infrastructure Law (also known as the Infrastructure Investment and Jobs Act), P.L. 117-58, on or after May 14, 2022, none of the funds under a federal award that are part of Federal financial assistance program for infrastructure may be obligated for a project unless all of the iron, steel, manufactured products, and construction materials used in the project are produced in the United States, unless subject to an approved waiver. The requirements of this section must be included in all subawards, including all contracts and purchase orders for work or products under this program. Recipients of an award of Federal financial assistance are hereby notified that none of the funds provided under this award may be used for a project for infrastructure unless:
1. all iron and steel used in the project are produced in the United States--this means all manufacturing processes, from the initial melting stage through the application of coatings, occurred in the United States;
  2. all manufactured products used in the project are produced in the United States—this means the manufactured product was manufactured in the United States; and the cost of the components of the manufactured product that are mined, produced, or manufactured in the United States is greater than 55 percent of the total cost of all components of the manufactured product, unless another standard for determining the minimum amount of domestic content of the manufactured product has been established under applicable law or regulation; and
  3. all construction materials are manufactured in the United States—this means that all manufacturing processes for the construction material occurred in the United States.

The Buy America preference only applies to articles, materials, and supplies that are consumed in, incorporated into, or affixed to an infrastructure project. As such, it does not apply to tools, equipment, and supplies, such as temporary scaffolding, brought to the construction site and removed at or before the completion of the infrastructure project. Nor does a Buy America preference apply to equipment and furnishings, such as movable chairs, desks, and portable computer equipment, that are used at or within the finished

infrastructure project but are not an integral part of the structure or permanently affixed to the infrastructure project.

For further information on the Buy America preference, please visit [www.doi.gov/grants/BuyAmerica](http://www.doi.gov/grants/BuyAmerica). Additional information can also be found at the White House Made in America Office website: [www.whitehouse.gov/omb/management/made-in-america/](http://www.whitehouse.gov/omb/management/made-in-america/).

### *Waivers*

When necessary, recipients may apply for, and the DOI may grant, a waiver from these requirements, subject to review by the Made in America Office. The DOI may waive the application of the domestic content procurement preference in any case in which it is determined that one of the below circumstances applies:

1. Non-availability Waiver: the types of iron, steel, manufactured products, or construction materials are not produced in the United States in sufficient and reasonably available quantities or of a satisfactory quality;
2. Unreasonable Cost Waiver: the inclusion of iron, steel, manufactured products, or construction materials produced in the United States will increase the cost of the overall project by more than 25 percent; or
3. Public Interest Waiver: applying the domestic content procurement preference would be inconsistent with the public interest.

There may be instances where an award qualifies, in whole or in part, for an existing DOI general applicability waiver as described at:

[www.doi.gov/grants/BuyAmerica/GeneralApplicabilityWaivers](http://www.doi.gov/grants/BuyAmerica/GeneralApplicabilityWaivers). If the specific financial assistance agreement, infrastructure project, or non-domestic materials meets the criteria of an existing general applicability waiver within the limitations defined within the waiver, the recipient is not required to request a separate waiver for non-domestic materials.

If a general applicability waiver does not already apply, and a recipient believes that one of the above circumstances applies to an award, a request to waive the application of the domestic content procurement preference may be submitted to the financial assistance awarding officer in writing. Waiver requests shall include the below information. The waiver shall not include any Privacy Act information, sensitive data, or proprietary information within their waiver request. Waiver requests will be posted to [www.doi.gov/grants/buyamerica](http://www.doi.gov/grants/buyamerica) and are subject to public comment periods of no less than 15 days. Waiver requests will also be reviewed by the Made in America Office.

1. Type of waiver requested (non-availability, unreasonable cost, or public interest).
2. Requesting entity and Unique Entity Identifier (UEI) submitting the request.
3. Department of Interior Bureau or Office who issued the award.
4. Federal financial assistance listing name and number (reference block 2 on DOI Notice of Award)

5. Financial assistance title of project (reference block 8 on DOI Notice of Award).
6. Federal Award Identification Number (FAIN).
7. Federal funding amount (reference block 11.m. on DOI Notice of Award).
8. Total cost of Infrastructure expenditures (includes federal and non-federal funds to the extent known).
9. Infrastructure project description(s) and location(s) (to the extent known).
10. List of iron or steel item(s), manufactured goods, and construction material(s) the recipient seeks to waive from Buy America requirements. Include the name, cost, countries of origin (if known), and relevant PSC or NAICS code for each.
11. A certification that the recipient made a good faith effort to solicit bids for domestic products supported by terms included in requests for proposals, contracts, and nonproprietary communications with the prime contractor.
12. A statement of waiver justification, including a description of efforts made (e.g., market research, industry outreach) by the recipient, in an attempt to avoid the need for a waiver. Such a justification may cite, if applicable, the absence of any Buy America-compliant bids received in response to a solicitation.
13. Anticipated impact if no waiver is issued.

Approved waivers will be posted at [www.doi.gov/grants/BuyAmerica/ApprovedWaivers](http://www.doi.gov/grants/BuyAmerica/ApprovedWaivers); recipients requesting a waiver will be notified of their waiver request determination by an awarding officer.

Questions pertaining to waivers should be directed to the financial assistance awarding officer.

#### *Definitions*

“Construction materials” includes an article, material, or supply that is or consists primarily of:

- non-ferrous metals;
- plastic and polymer-based products (including polyvinylchloride, composite building materials, and polymers used in fiber optic cables);
- glass (including optic glass);
- lumber; or
- drywall.

“Construction Materials” does **not** include cement and cementitious materials, aggregates such as stone, sand, or gravel, or aggregate binding agents or additives.

“Domestic content procurement preference” means all iron and steel used in the project are produced in the United States; the manufactured products used in the project are produced in the United States; or the construction materials used in the project are produced in the United States.

“Infrastructure” includes, at a minimum, the structures, facilities, and equipment for, in the United States, roads, highways, and bridges; public transportation; dams, ports, harbors, and other maritime facilities; intercity passenger and freight railroads; freight and intermodal facilities; airports; water systems, including drinking water and

wastewater systems; electrical transmission facilities and systems; utilities; broadband infrastructure; and buildings and real property. Infrastructure includes facilities that generate, transport, and distribute energy.

“Project” means the construction, alteration, maintenance, or repair of infrastructure in the United States

## **12. DEFINITIONS & ACRONYMS**

**Agency Review:** If a recipient has a history of poor performance, financial instability, has a management system not meeting standards prescribed by the Uniform Administrative Requirements, has not conformed to the terms and conditions of the award, and/or is not otherwise responsible in safeguarding federal funds, they may be placed on Agency Review. Agency Review limits a recipient's access to funds by requiring that all payments must be requested, reviewed, and approved prior to their being released.

**Award Recipient:** The Award Recipient is the recipient's individual who is authorized to act for the applicant and to assume the obligations imposed by the Federal laws, regulations, requirements, and conditions that apply to grant applications or grant awards.

**BLM:** Bureau of Land Management may, also be referred to as Bureau.

**CFR:** Code of Federal Regulations.

**DOI:** Department of the Interior.

**FFR:** Federal Financial Report or Standard Form (SF) 425.

**Financial Assistance Agreement:** This grant or cooperative agreement. The term grant is defined as all Federal financial assistance that provides support or stimulation to accomplish a public purpose. Use of the term “grant” includes grants and/or cooperative agreements awarded by the Federal Government to eligible recipients.

**Federal Award Date:** The date when the Federal award is sign by the BLM Grants Management Officer

**FY:** Federal Fiscal Year which runs from October 1 through September 30 each year.

**GMO:** Grants Management Officer, the only individual in the BLM who is authorized to obligate funds, award, modify, and/or terminate assistance agreements.

**GMS:** Grants Management Specialist, the administrative individual authorized to prepare assistance agreement awards and modifications, but who cannot obligate funds, award, modify, and/or terminate the agreement.

Nomination: Means the Recipient's proposal for SNPLMA funding. The term "nomination" is used synonymously and interchangeably with the term "project."

NHPA: National Historic Preservation Act

NTE: Not-to-exceed amount, the maximum Federal funding amount available for reimbursement to the recipient.

OMB: The Office of Management and Budget. OMB leads development of government-wide policy to assure that grants are managed properly and that Federal dollars are spent in accordance with applicable laws and regulations. OMB Circulars that apply to this agreement may be found on the OMB Website, URL: [http://www.whitehouse.gov/omb/circulars\\_default/](http://www.whitehouse.gov/omb/circulars_default/).  
[http://www.whitehouse.gov/omb/circulars\\_default/](http://www.whitehouse.gov/omb/circulars_default/)

PI: The BLM Project Inspector, the technical advisor assisting the BLM Program Officer in administering and monitoring the technical aspects of the agreement. The Project Inspector is not authorized to modify this agreement or obligate the Government in any way.

PO: The BLM Program Officer, appointed for the purposes of monitoring the technical aspects of the agreement. The PO will work closely with the RPM and is authorized to clarify technical requirements, and review and approve work which is clearly within the objectives specified in this agreement. The PO will review financial, performance, and youth employment reports, and review and recommend approval of payments to the GMO if a recipient is on Agency Review. The PO is not authorized to modify this agreement or obligate the Government in any way.

Recipient: The organization and/or individual named in Box 5. of the "Grant and Cooperative Agreement" cover sheet.

RPM: The recipient's Project or Program Manager, designated to direct the project or activity being supported by the agreement. The RPM is responsible and accountable to the recipient and BLM for the proper implementation of the project or activity.

SMART: Stands for the "SNPLMA Management and Reporting Tool." SMART is an online database accessible through [www.blm.gov/snplma](http://www.blm.gov/snplma) and is the required platform to complete the work plan, reimbursement requests (aka forecasting drawdowns to occur through ASAP), and all reporting requirements of the SNPLMA Implementation Agreement.

SNPLMA: The Southern Nevada Public Land Management Act of 1998 (SNPLMA), Public Law 105-263, as amended. SNPLMA authorizes the Secretary of the Interior to expend funds from the SNPLMA Special Account for the development of parks, trails, and natural areas in Clark, Lincoln, and White Pine Counties, and Carson City in Nevada (subject to limitations); development and implementation of multi-species habitat conservation plan in Clark County, Nevada; and development and implementation of comprehensive, cost-effective, multi-jurisdictional hazardous fuels reduction and wildfire prevention projects for the Lake Tahoe

Basin, the Carson Range in Douglas and Washoe Counties and Carson City in Nevada, and the Spring Mountains in southern Nevada (subject to limitations).

SNPLMA Implementation Agreement: The SNPLMA Implementation Agreement is a document that contains the business rules necessary for the nomination, approval, implementation, modification, closeout, reporting, and compliance with all SNPLMA-funded projects or nominations. The SNPLMA Implementation Agreement is accessible online through [www.blm.gov/snplma](http://www.blm.gov/snplma).

### 13. FULL TEXT TERMS AND CONDITIONS

#### 1. Department of Interior Conflict of Interest Term and Condition:

- a. The Recipient must establish safeguards to prohibit its employees and Subrecipients from using their positions for purposes that constitute or present the appearance of a personal or organizational conflict of interest. The Recipient is responsible for notifying the Grants Officer in writing of any actual or potential conflicts of interest that may arise during the life of this award. Conflicts of interest include any relationship or matter which might place the Recipient or its employees in a position of conflict, real or apparent, between their responsibilities under the agreement and any other outside interests. Conflicts of interest may also include, but are not limited to, direct or indirect financial interests, close personal relationships, positions of trust in outside organizations, consideration of future employment arrangements with a different organization, or decision-making affecting the award that would cause a reasonable person with knowledge of the relevant facts to question the impartiality of the Recipient and/or Recipient's employees and Sub-recipients in the matter.
- b. The Grants Officer and the servicing Ethics Counselor will determine if a conflict of interest exists. If a conflict of interest exists, the Grants Officer will determine whether a mitigation plan is feasible. Mitigation plans must be approved by the Grants Officer in writing. Failure to resolve conflicts of interest in a manner that satisfies the government may be cause for termination of the award.
- c. Failure to make required disclosures may result in any of the remedies described in 2 CFR §200.338, Remedies for Noncompliance, including suspension or debarment (see also 2 CFR Part 180).
- d. Definitions:
  - (1) Conflict of Interest is defined as any relationship or matter which might place the Recipient, its employees, and/or its Subrecipients in a position of conflict, real or apparent, between their responsibilities under the agreement and any other outside interests. Conflicts of interest may also include, but are not limited to, direct or indirect financial interests, close personal relationships, positions of trust in outside organizations, consideration of future employment arrangements with a different organization, or decision-making affecting the award that would cause a reasonable person with knowledge of the relevant facts to question the impartiality of the Recipient and/or Recipient's employees and Subrecipients in the matter.
  - (2) Close Personal Relationship means a Federal award program employee's childhood or other friend, sibling, or other family relations that may compromise

or impair the fairness and impartiality of the Proposal Evaluator and Advisor and Grants Officer in the review, selection, award, and management of a financial assistance award.

- (3) Discretionary Federal Financial Assistance means Federal awards including grants and agreements that are awarded at the discretion of the agency.
- (4) Employment means:
  - (a) In any capacity, even if otherwise permissible, by any applicant or potential applicant for a Federal financial assistance award;
  - (b) Employment within the last 12 months with a different organization applying for some portion of the award's approved project activities and funding to complete them OR expected to apply for and to receive some portion of the award; and/or
  - (c) Employment with a different organization of any member of the organization employee's household or a relative with whom the organization's employee has a close personal relationship who is applying for some portion of the award's approved project activities and funding to complete them OR expected to apply for and to receive some portion of the award.
  - (d) Non-Federal entity means a State, local government, Indian tribe, institution of higher education, or nonprofit organization that carries out a Federal award as a Recipient or Subrecipient.
  - (e) Recipient means a non-Federal entity that receives a Federal award directly from a Federal awarding agency to carry out an activity under a Federal program. The term Recipient does not include Subrecipients.
  - (f) Subrecipient means a non-Federal entity that receives a subaward from a pass-through entity to carry out part of a Federal program but does not include an individual who is a beneficiary of such program. A Subrecipient may also be a recipient of other Federal awards directly from a Federal awarding agency.

#### **4. MINIMUM WAGES UNDER EXECUTIVE ORDER 13658 (January 2015)**

- (a) Definitions. As used in this clause—

“United States” means the 50 states and the District of Columbia.

“Worker”—

- (1) Means any person engaged in performing work on, or in connection with, a contract covered by Executive Order 13658, and
  - (i) Whose wages under such contract are governed by the Fair Labor Standards Act (29 U.S.C. chapter 8), the Service Contract Labor Standards statute (41 U.S.C. chapter 67), or the Wage Rate Requirements (Construction) statute (40 U.S.C. chapter 31, subchapter IV),
  - (ii) Other than individuals employed in a bona fide executive, administrative, or professional capacity, as those terms are defined in 29 CFR Part 541,
  - (iii) Regardless of the contractual relationship alleged to exist between the individual and the employer.
- (2) Includes workers performing on, or in connection with, the contract whose wages are calculated pursuant to special certificates issued under 29 U.S.C. 214(c).



- 
- (3) Also includes any person working on, or in connection with, the contract and individually registered in a bona fide apprenticeship or training program registered with the Department of Labor's Employment and Training Administration, Office of Apprenticeship, or with a State Apprenticeship Agency recognized by the Office of Apprenticeship.
- (b) Executive Order Minimum Wage rate.
- (1) The Contractor shall pay to workers, while performing in the United States, and performing on, or in connection with, this contract, a minimum hourly wage rate of \$10.10 per hour beginning January 1, 2015.
- (2) The Contractor shall adjust the minimum wage paid, if necessary, beginning wage. The Administrator of the Department of Labor's Wage and Hour Division (the Administrator) will publish annual determinations in the Federal Register no later than 90 days before the effective date of the new E.O. minimum wage rate. The Administrator will also publish the applicable E.O. minimum wage on [www.wdol.gov](http://www.wdol.gov) (or any successor Web site) and on all wage determinations issued under the Service Contract Labor Standards statute or the Wage Rate Requirements (Construction) statute. The applicable published E.O. minimum wage is incorporated by reference into this contract.
- (3) (i) The Contractor may request a price adjustment only after the effective date of the new annual E.O. minimum wage determination. Prices will be adjusted only if labor costs increase as a result of an increase in the annual E.O. minimum wage, and for associated labor costs and relevant subcontract costs. Associated labor costs shall include increases or decreases that result from changes in social security and unemployment taxes and workers' compensation insurance but will not otherwise include any amount for general and administrative costs, overhead, or profit.
- (ii) Subcontractors may be entitled to adjustments due to the new minimum wage, pursuant to paragraph (b)(2). Contractors shall consider any subcontractor requests for such price adjustment.
- (iii) The Contracting Officer will not adjust the contract price under this clause for any costs other than those identified in paragraph (b)(3)(i) of this clause and will not provide duplicate price adjustments with any price adjustment under clauses implementing the Service Contract Labor Standards statute or the Wage Rate Requirements (Construction) statute.
- (4) The Contractor warrants that the prices in this contract do not include allowance for any contingency to cover increased costs for which adjustment is provided under this clause.
- (5) A pay period under this clause may not be longer than semi-monthly but may be shorter to comply with any applicable law or other requirement under this contract establishing a shorter pay period. Workers shall be paid no later than one pay period following the end of the regular pay period in which such wages were earned or accrued.
- (6) The Contractor shall pay, unconditionally to each worker, all wages due free and clear without subsequent rebate or kickback. The Contractor may make deductions that reduce a worker's wages below the E.O. minimum wage rate only if done in accordance with 29 CFR §10.23, Deductions.

- 
- (7) The Contractor shall not discharge any part of its minimum wage obligation under this clause by furnishing fringe benefits or, with respect to workers whose wages are governed by the Service Contract Labor Standards statute, the cash equivalent thereof.
- (8) Nothing in this clause shall excuse the Contractor from compliance with any applicable Federal or State prevailing wage law or any applicable law or municipal ordinance establishing a minimum wage higher than the E.O. minimum wage. However, wage increases under such other laws or municipal ordinances are not subject to price adjustment under this subpart.
- (9) The Contractor shall pay the E.O. minimum wage rate whenever it is higher than any applicable collective bargaining agreement(s) wage rate.
- (10) The Contractor shall follow the policies and procedures in 29 CFR §10.24(b) and 10.28 for treatment of workers engaged in an occupation in which they customarily and regularly receive more than \$30 a month in tips.
- (c) (1) This clause applies to workers as defined in paragraph (a). As provided in that definition—
- (i) Workers are covered regardless of the contractual relationship alleged to exist between the contractor or subcontractor and the worker;
  - (ii) Workers with disabilities whose wages are calculated pursuant to special certificates issued under 29 U.S.C. 214(c) are covered; and
  - (iii) Workers who are registered in a bona fide apprenticeship program or training program registered with the Department of Labor's Employment and Training Administration, Office of Apprenticeship, or with a State Apprenticeship Agency recognized by the Office of Apprenticeship, are covered.
- (2) This clause does not apply to—
- (i) Fair Labor Standards Act (FLSA)-covered individuals performing in connection with contracts covered by the E.O., i.e., those individuals who perform duties necessary to the performance of the contract, but who are not directly engaged in performing the specific work called for by the contract, and who spend less than 20 percent of their hours worked in a particular workweek performing in connection with such contracts;
  - (ii) Individuals exempted from the minimum wage requirements of the FLSA under 29 U.S.C. 213(a) and 214(a) and (b), unless otherwise covered by the Service Contract Labor Standards statute, or the Wage Rate Requirements (Construction) statute. These individuals include but are not limited to—
    - (a) Learners, apprentices, or messengers whose wages are calculated pursuant to special certificates issued under 29 U.S.C. 214(a).
    - (b) Students whose wages are calculated pursuant to special certificates issued under 29 U.S.C. 214(b).
    - (c) Those employed in a bona fide executive, administrative, or professional capacity (29 U.S.C. 213(a)(1) and 29 CFR Part 541).
    - (d) Notice. The Contractor shall notify all workers performing work on, or in connection with, this contract of the applicable E.O. minimum wage rate under this clause. With respect to workers covered by the Service Contract Labor Standards statute or the Wage Rate Requirements (Construction) statute, the Contractor may meet this requirement by posting, in a

prominent and accessible place at the worksite, the applicable wage determination under those statutes. With respect to workers whose wages are governed by the FLSA, the Contractor shall post notice, utilizing the poster provided by the Administrator, which can be obtained at [www.dol.gov/whd/govcontracts](http://www.dol.gov/whd/govcontracts), in a prominent and accessible place at the worksite. Contractors that customarily post notices to workers electronically may post the notice electronically provided the electronic posting is displayed prominently on any Web site that is maintained by the contractor, whether external or internal, and customarily used for notices to workers about terms and conditions of employment.

(e) Payroll Records.

(1) The Contractor shall make and maintain records, for three years after completion of the work, containing the following information for each worker:

- (i) Name, address, and social security number;
- (ii) The worker's occupation(s) or classification(s);
- (iii) The rate or rates of wages paid;
- (iv) The number of daily and weekly hours worked by each worker;
- (v) Any deductions made; and
- (vi) Total wages paid.

(2) The Contractor shall make records pursuant to paragraph (e)(1) of this clause available for inspection and transcription by authorized representatives of the Administrator. The Contractor shall also make such records available upon request of the Contracting Officer.

(3) The Contractor shall make a copy of the contract available, as applicable, for inspection or transcription by authorized representatives of the Administrator.

(4) Failure to comply with this paragraph (e) shall be a violation of 29 CFR §10.26 and this contract. Upon direction of the Administrator or upon the Contracting Officer's own action, payment shall be withheld until such time as the noncompliance is corrected.

(5) Nothing in this clause limits or otherwise modifies the Contractor's payroll and recordkeeping obligations, if any, under the Service Contract Labor Standards statute, the Wage Rate Requirements (Construction) statute, the Fair Labor Standards Act, or any other applicable law.

(f) Access. The Contractor shall permit authorized representatives of the Administrator to conduct investigations, including interviewing workers at the worksite during normal working hours.

(g) Withholding. The Contracting Officer, upon his or her own action or upon written request of the Administrator, will withhold funds or cause funds to be withheld from the Contractor under this or any other Federal contract with the same Contractor, sufficient to pay workers the full amount of wages required by this clause.

(h) Disputes. Department of Labor has set forth in 29 CFR §10.51, Disputes concerning contractor compliance, the procedures for resolving disputes

---

concerning a contractor's compliance with Department of Labor regulations at 29 CFR Part 10. Such disputes shall be resolved in accordance with those procedures and not the Disputes clause of this contract. These disputes include disputes between the Contractor (or any of its subcontractors) and the contracting agency, the Department of Labor, or the workers or their representatives.

- (i) Anti-retaliation. The Contractor shall not discharge or in any other manner discriminate against any worker because such worker has filed any complaint or instituted or caused to be instituted any proceeding under or related to compliance with the E.O. or this clause or has testified or is about to testify in any such proceeding.
- (j) Subcontractor compliance. The Contractor is responsible for subcontractor compliance with the requirements of this clause and may be held liable for unpaid wages due subcontractor workers.
- (k) Subcontracts. The Contractor shall include the substance of this clause, including this paragraph (k) in all subcontracts, regardless of dollar value, that are subject to the Service Contract Labor Standards statute or the Wage Rate Requirements (Construction) statute, and are to be performed in whole or in part in the United States.

***END OF AGREEMENT***

1. DATE ISSUED MM/DD/YYYY 01/30/2023

1a. SUPERSEDES AWARD NOTICE dated 11/17/2022 except that any additions or restrictions previously imposed remain in effect unless specifically rescinded

2. CFDA NO. 15.235 - Southern Nevada Public Land Management

3. ASSISTANCE TYPE Cooperative Agreement

4. GRANT NO. L23AC00007-01  
Originating MCA #

5. TYPE OF AWARD Other

4a. FAIN L23AC00007

5a. ACTION TYPE Post Award Amendment

6. PROJECT PERIOD MM/DD/YYYY  
From 11/17/2022 Through 11/16/2027

7. BUDGET PERIOD MM/DD/YYYY  
From 11/17/2022 Through 11/16/2027

**NOTICE OF AWARD**



AUTHORIZATION (Legislation/Regulations)  
Southern Nevada Public Land Management Act of 1998, 31 U.S.C. 6901, PL 105-263

8. TITLE OF PROJECT (OR PROGRAM)  
SNPLMA Project CR04, Priority 18-04 Carson River Trail System Phase III - Prison Hill West

9a. GRANTEE NAME AND ADDRESS  
CITY OF CARSON CITY  
201 N Carson St  
Carson City, NV, 89701-4594

9b. GRANTEE PROJECT DIRECTOR  
Gregg Berggren  
201 N Carson St STE 5  
Carson City, NV, 89701-4289  
Phone: 775-283-7219

10a. GRANTEE AUTHORIZING OFFICIAL  
Lyndsey Boyer  
201 N Carson St Ste 5  
Carson City, NV, 89701-4289  
Phone: 775-283-7341

10b. FEDERAL PROJECT OFFICER  
Ms. Michelle Eis  
1340 Financial  
Reno, NV, 89520  
Phone: 775-861-6418

**ALL AMOUNTS ARE SHOWN IN USD**

11. APPROVED BUDGET (Excludes Direct Assistance)		12. AWARD COMPUTATION	
I Financial Assistance from the Federal Awarding Agency Only		a. Amount of Federal Financial Assistance (from item 11m)	\$ 2,403,250.00
II Total project costs including grant funds and all other financial participation		b. Less Unobligated Balance From Prior Budget Periods	\$ 0.00
a. Salaries and Wages	\$ 45,601.40	c. Less Cumulative Prior Award(s) This Budget Period	\$ 2,403,250.00
b. Fringe Benefits	\$ 0.00	<b>d. AMOUNT OF FINANCIAL ASSISTANCE THIS ACTION</b>	<b>\$ 0.00</b>
c. Total Personnel Costs	\$ 45,601.40	<b>13. Total Federal Funds Awarded to Date for Project Period</b>	<b>\$ 2,403,250.00</b>
d. Equipment	\$ 0.00	<b>14. RECOMMENDED FUTURE SUPPORT</b> (Subject to the availability of funds and satisfactory progress of the project):	
e. Supplies	\$ 0.00	YEAR	TOTAL DIRECT COSTS
f. Travel	\$ 0.00	a. 2	\$
g. Construction	\$ 0.00	b. 3	\$
h. Other	\$ 0.00	c. 4	\$
i. Contractual	\$ 2,375,148.60	d. 5	\$
j. TOTAL DIRECT COSTS	\$ 2,420,750.00	e. 6	\$
k. INDIRECT COSTS	\$ 0.00	f. 7	\$
<b>l. TOTAL APPROVED BUDGET</b>	<b>\$ 2,420,750.00</b>	<b>15. PROGRAM INCOME SHALL BE USED IN ACCORD WITH ONE OF THE FOLLOWING ALTERNATIVES:</b>	
m. Federal Share	\$ 2,403,250.00	a. DEDUCTION	
n. Non-Federal Share	\$ 17,500.00	b. ADDITIONAL COSTS	
		c. MATCHING	
		d. OTHER RESEARCH (Add / Deduct Option)	
		e. OTHER (See REMARKS)	
		<b>e</b>	
		<b>16. THIS AWARD IS BASED ON AN APPLICATION SUBMITTED TO, AND AS APPROVED BY, THE FEDERAL AWARING AGENCY ON THE ABOVE TITLED PROJECT AND IS SUBJECT TO THE TERMS AND CONDITIONS INCORPORATED EITHER DIRECTLY OR BY REFERENCE IN THE FOLLOWING:</b>	
		a. The grant program legislation	
		b. The grant program regulations.	
		c. This award notice including terms and conditions, if any, noted below under REMARKS.	
		d. Federal administrative requirements, cost principles and audit requirements applicable to this grant.	
		In the event there are conflicting or otherwise inconsistent policies applicable to the grant, the above order of precedence shall prevail. Acceptance of the grant terms and conditions is acknowledged by the grantee when funds are drawn or otherwise obtained from the grant payment system.	

REMARKS (Other Terms and Conditions Attached -  Yes  No)

THE PURPOSE OF THIS MODIFICATION IS TO CORRECT THE FEDERAL AWARD PERFORMANCE GOALS FOR THIS PROJECT IN ATTACHMENT A.

ALL OTHER TERMS AND CONDITIONS REMAIN THE SAME.

**GRANTS MANAGEMENT OFFICIAL:**

Tamera Freeman, Grants Management Officer  
1340 Financial Blvd  
Reno, NV, 89502-7147  
Phone: 775-861-6587

17. VENDOR CODE	0070163745	18a. UEI DTBPJMA2QFC8	18b. DUNS 073787152	19. CONG. DIST.	02	
LINE#	FINANCIAL ACCT	AMT OF FIN ASST	START DATE	END DATE	TAS ACCT	PO LINE DESCRIPTION

NOTICE OF AWARD (Continuation Sheet)

PAGE 2 of 2	DATE ISSUED 01/30/2023
GRANT NO. L23AC00007-01	

Federal Financial Report Cycle			
Reporting Period Start Date	Reporting Period End Date	Reporting Type	Reporting Period Due Date
11/17/2022	09/30/2023	Annual	12/29/2023
10/01/2023	09/30/2024	Annual	12/29/2024
10/01/2024	09/30/2025	Annual	12/29/2025
10/01/2025	09/30/2026	Annual	12/29/2026
10/01/2026	09/30/2027	Annual	12/29/2027
10/01/2027	11/16/2027	Final	03/15/2028

Performance Progress Report Cycle			
Reporting Period Start Date	Reporting Period End Date	Reporting Type	Reporting Period Due Date
11/17/2022	09/30/2023	Annual	12/29/2023
10/01/2023	09/30/2024	Annual	12/29/2024
10/01/2024	09/30/2025	Annual	12/29/2025
10/01/2025	09/30/2026	Annual	12/29/2026
10/01/2026	09/30/2027	Annual	12/29/2027
10/01/2027	11/16/2027	Final	03/15/2028

# AWARD ATTACHMENTS

CITY OF CARSON CITY

L23AC00007-01

---

1. T&C CR04\_corrected performance goals

---

**1. COOPERATIVE AGREEMENT OBJECTIVES:****A. Objective(s):**

Carson City will design and construct a non-motorized multi-use trail approximately 2.5 miles in length along the west side of Prison Hill and make improvements to the existing Koontz Lane trailhead in Carson City, Nevada. Improvements to the trailhead will include regrading an access road and improve drainage, regrade, and reshape a parking area, install an ADA accessible single-vault toilet and picnic table with shade structure. This project will continue an ongoing effort to create a network of trails that connect neighborhoods to parks and open space lands in the Carson River/Prison Hill area; enhance recreational opportunities for families and those with mobility challenges; and improve visitor safety while maintaining conservation values of these important properties.

**B. Public Benefit(s):**

1. Improve the quality of life for all public in urban and rural communities by enhancing recreational opportunities that connect people with the outdoor environment.
2. Promoting project connectivity and sustainability between new or existing recreation opportunities and other community facilities accommodations, and services (e.g., community centers, schools, or mass transit).
3. Provide recreational opportunities and improve access to those opportunities on Federal, State, local and regional government lands by increasing the availability and quality of public recreation.
4. Protect or improve the integrity of environmental, cultural, historical, educational, community, recreational, and open space resources to enhance the quality of the human experience and by increasing the community's understanding and appreciation of the natural outdoor environment.

**C. Federal Award Performance Goals:**

- Develop design plans and specifications for, and construction of, a non-motorized multi-use trail 10'-12' wide and ±2.5 miles long, connecting three existing trailheads.
- Develop design plans and specifications for, and construction of, improvements to the existing Koontz Lane trailhead. This will include:
  - o Regrade ±1,100 feet of access road and improve drainage.
  - o Regrade and reshape parking area to drain properly and accommodate 20 to 30 vehicles and 2 to 3 horse trailers; top with 3" of road base.
  - o Install one ADA accessible single vault toilet.
  - o Install one ADA accessible picnic table with shade structure.
  - o Install two ADA compliant parking spaces.
  - o Install an ADA pathway from parking spaces to toilet and picnic table.
  - o Install dog waste disposal station.
  - o Install split-rail fencing to delineate parking area and prevent impacts to vegetation.
  - o Install animal resistant trash receptacle.
- Develop plans and specifications for, and construction of, a safe street crossing on Edmonds Drive at Koontz Lane to facilitate connectivity with the adjacent neighborhood and other trail systems in Carson City.



- Develop and install four interpretive signs at appropriate locations along the trail. One of these signs will be developed in cooperation with the local Washoe Tribe and will include history of Native American people as related to the Carson River/Prison Hill area.
- Revegetation of approximately three acres in the areas disturbed during construction.

## 2. PROPOSED WORK

- A. The Recipient's Nomination Package dated 09/14/2020, as submitted through the SNPLMA Round 18 nomination process, entitled "*Carson River Trails Phase III - Prison Hill West*," and assigned SNPLMA project number CR04, priority number 18-04, is accepted by the BLM and incorporated herein, as part of this agreement. The recipient will also develop and maintain a project workplan, as accepted by the BLM, in the SNPLMA Management and Reporting Tool or "SMART" online database.

Additional documents incorporated by reference: Recipient GrantSolutions application number LSNPLMA-2022-000038, dated 03/28/2022 to include Standard Form (SF) 424 Application for Federal Assistance, SF-424A (Budget Information - Non-Construction Programs), Budget Detail, signed Certification Regarding Lobbying - Certification for Contracts, Grants, Loans, or Cooperative Agreement.

Additionally, the recipient agrees to:

- Adhere to the policies and procedures identified in the effective SNPLMA Implementation Agreement.
- Adhere to the Recipient procurement plan and federal procurement standards under 2 CFR § 200.318. Ensure federal, state, and local government permits are obtained, if required.
- Initiate, complete, and provide proof of documentation compliance with federal environmental and cultural resource laws, e.g., National Environmental Policy Act (NEPA), Endangered Species Act (ESA), Migratory Bird Treaty Act, and the National Historic Preservation Act (NHPA), as applicable.
  - The Grant Management Officer (GMO) and Program Officer (PO) will provide additional information on the NEPA and NHPA compliance in a separate document.
  - The recipient must provide to the GMO and PO documentation that confirms compliance is satisfactorily completed before the recipient will be allowed to proceed project implementation. When proof of compliance has been provided, the PO will respond in writing (email or letter) to the recipient (and e-copy the GMO) a "SNPLMA notice to proceed" to allow the recipient to proceed with project implementation.
- Include the following conspicuously placed disclosure for materials generated for display or distribution (brochures, flyers, public planning documents, public scoping meetings, videos, etc.): "This project was funded due to the Southern Nevada Public Land Management Act, which authorized the sale of BLM-administered federal lands within a designated boundary in the Las Vegas Valley

and required proceeds to be used on projects to fund federal, state and local projects that benefit communities and public lands.”

- Provide project signage conspicuously placed, which states: “This project was funded due to the Southern Nevada Public Land Management Act, which authorized the sale of BLM-administered federal lands within a designated boundary in the Las Vegas Valley and required proceeds to be used on projects to fund federal, state, and local projects that benefit communities and public lands.”

B. In addition, the BLM will:

- Review and accept the recipient’s project work plan before funds are authorized for expenditure.
- Approve the recipient to transition from planning activities to implementation of the project objectives following the acceptance of prerequisite environmental, cultural/historic, and/or land-use compliance and documentation requirements.
- Closely monitor the project’s quarterly status information for scope, time, and amount and its compliance with the SNPLMA Implementation Agreement.
- Conduct a pre-work, progress, and final site visits.
- Manage the change management process, including the request, decision, and post-decision actions involving the project’s scope, time, and amount.
- Ensure completion of the project’s deliverable(s), accurate reporting of accomplishments, and public accomplishment information in annual reports and databases.

C. The recipient will also be responsible for significant developments, i.e., events which may occur between the scheduled performance reporting dates that have significant impact upon the supported activity. In such cases, the recipient must inform the PO as soon as the following types of conditions become known:

1. Problems, delays, or adverse conditions which will materially impair the ability to meet the objective of the Federal award. This disclosure must include a statement of the action taken, or contemplated, and any assistance needed to resolve the situation.
2. Favorable developments which enable meeting time schedules and objectives sooner or at less cost than anticipated or producing more or different beneficial results than originally planned.

### **3. TERM OF AGREEMENT**

A. The term, or period of performance, of this agreement shall become effective as of the date shown on the signed award cover page and may remain in effect for a maximum of five (5) years.

The BLM will consider continued support of the project upon; (a) the recipient showing progress satisfactory to the BLM toward program goals and the determination by the

BLM that continuation of the program would be in the best interests of the Government, (b) project is still in line with management's top priorities, and/or (c) the availability of funds.

#### B. Budget and Program Revisions

1. Recipients must submit in writing to the BLM's PO any request for budget or program revision in accordance with 2 CFR §200.308.
2. Modifications:
  - Requests to modify this Agreement's scope, time, or amount will require advance approval of the authorized SNPLMA official. A request for modification must be made to the SNPLMA Division using the modification request form in the SNPLMA Implementation Agreement, Part Two, Appendix L Project Modification Form.
  - Request to modify this Agreement's scope, time or amount shall be submitted no later than 120 calendar days before the current Agreement end date.
  - Requests for extensions for the reimbursement of funds will be considered on a case-by-case basis.
  - Requests to modify this Agreement's scope, time, or amount that receive approval from the SNPLMA Division via a decision memo signed by the SNPLMA authorized representative must complete additional steps/documentation to modify this Agreement through Grant Solutions and receive a modified agreement executed by the GMO.
  - This Agreement may be modified by written agreement signed by both the Recipient's Authorized Representative and the GMO. Administrative changes (i.e., GMO or PO name change, etc.) that do not change the work plan, scope, time, or amount, may be unilaterally signed by the GMO.
  - All other changes shall be made by bilateral modification to the Agreement. No oral statement made by any person, or written statement by any person other than the GMO, shall be allowed in any manner or degree to modify or otherwise effect the terms of the Agreement.

- C. Termination. This agreement may be terminated in accordance with the provisions of 2 CFR, Subpart D, §200.339 Termination and the procedures outlined in the SNPLMA Implementation Agreement.

#### 4. FINANCIAL SUPPORT AND PAYMENT METHOD

- A. Funding. The Recipient agrees not to exceed the total amount of available incremental funding. The Government is not obligated to reimburse the Recipient for the Recipient's expenditure of amounts in excess of the total available incremental funding nor is the Recipient obligated to continue performance beyond the incrementally funded amount. The obligation of funds for future incremental payments shall be subject to the availability of funds.

---

Funds obligated but not expended by the Recipient in a fiscal year may be carried forward and expended in subsequent fiscal years consistent with the period of performance in this Agreement.

- B. **Maximum Obligations.** The Recipient agrees not to exceed the total amount of available incremental funding. The Government is not obligated to reimburse the Recipient for the Recipient's expenditure of amounts in excess of the total available incremental funding nor is the Recipient obligated to continue performance beyond the incrementally funded amount. The obligation of funds for future incremental payments shall be subject to the availability of funds.

The total obligations, including modifications, represent the amount for which the BLM will be responsible under the terms of this agreement. The BLM shall not be responsible to pay for, nor shall the recipient be responsible to perform, any effort that will require the expenditure of Federal funds above the current obligated amount.

- C. **Reimbursable Costs and Limitations.** The recipient shall not incur costs or obligate funds for any purpose pertaining to operation of the program or activities beyond the expiration date stated in the agreement. The BLM's financial participation is limited. The BLM will only fund up to its share of those amounts requested in the project proposal and as are subsequently approved and funded in the agreement. The recipient shall not be obligated to continue performance under the agreement or to incur costs in excess of the costs set forth in the proposal and subsequent agreement. However, if the Recipient chooses to expend funds in excess of the approved project budget, the Recipient will be responsible to fund the excess without funding participation by the Bureau.

D. **Cost Sharing and Matching**

Cost sharing for this agreement shall be in accordance with 2 CFR, Subpart D, §200.306, Cost sharing or matching.

1. There is no cost share or match legislatively required for this award.
2. If the recipient voluntarily included cost sharing or matching in the approved nomination, then the recipient will be required to document the cost-share or match in accordance with the 2 CFR, Subpart D, §200.306, Cost sharing or matching.

E. **Program Income**

Program income generated under this award can be as follows:

1. Program income generated for this agreement shall be in accordance with **2 CFR, Subpart D, §200.307(e)(3) Cost Sharing or Matching** - Program income may be used to meet the cost sharing or matching requirement of the Federal award. The amount of the Federal award remains the same. Program income generated through the performance of this project must be reported on SF 425, Federal Financial Report (see section **6. PERFORMANCE, FINANCIAL, AND OTHER REPORTING**).

## F. Indirect Costs

1. The Recipient has never had a federally approved negotiated indirect rate, and as the BLM is the cognizant agency, the Recipient has requested and received approval from the BLM for reimbursement under this agreement at the de minimis rate shown on the award cover sheet under "Indirect Cost Rate." This rate is to be applied to the agreement's base modified total direct costs (MTDC). MTDC consist of all salaries and wages, fringe benefits, materials and supplies, services, travel, and subgrants and subcontracts up to the first \$25,000 of each subgrant or subcontract (regardless of the period covered by the subgrant or subcontract). Equipment, capital expenditures, charges for patient care, rental costs, and the portion of subgrants or subcontracts in excess of \$25,000 shall be excluded from TDC. Participant support costs shall generally be excluded from MTDC.

## G. Payment by Reimbursement

1. Payment will be made by draw-down reimbursement through the Department of the Treasury, Automated Standard Application for Payment (ASAP) System. See following website: <http://www.fms.treas.gov/asap> Treasury Circular 1075 (31 CFR §205) requires that drawdowns to a recipient organization shall be limited to the minimum amounts needed and shall be timed to be in accordance with the actual, immediate cash requirements of the recipient organization in carrying out the purposes of the approved program or project. The timing and amount of cash advances shall be as close as is administratively feasible to the actual disbursements by the recipient organization for direct program or project costs and the proportionate share of any allowable indirect costs.
2. Funds that are available from repayments to and interest earned on a revolving fund, program income, rebates, refunds, contract settlements, audit recoveries, credits, discounts, and interest earned on any of those funds, must be disbursed before requesting additional cash payments.
3. ASAP Draw Down Requirements for SNPLMA Projects:
  - Prior to requesting an ASAP drawdown, the Recipient shall send an email to the appropriate program specific PO (aka SNPLMA Program Manager) and e-copy the BLM representatives identified below, with the amount of funding to be drawn down **at least 3 days before** requesting the ASAP draw down. If the ASAP draw down request contains multiple projects by the Recipient, the Recipient shall provide the PO a list of the projects to draw down funds separated by agreement number and amount.
    - Michelle Leiber, [mleiber@blm.gov](mailto:mleiber@blm.gov) - PO/SNPLMA Program Manager for the Parks, Trails, and Natural Areas (PTNA) and Multi-Species Habitat Conservation Plan (MSHCP) categories; **and e-copy**

- 
- Amy Lee, [alee@blm.gov](mailto:alee@blm.gov) – SNPLMA Sr. Accountant, BLM National Operations Center (NOC);
  - Gary Thompson - [gthomps@blm.gov](mailto:gthomps@blm.gov) – SNPLMA Accountant, BLM NOC; and
  - Robert Wandel, [rwandel@blm.gov](mailto:rwandel@blm.gov) – SNPLMA Assistant District Manager, BLM SNPLMA Division.
- An ASAP draw down will be made only in the amount(s) necessary to meet the current reimbursement needs. The GMO and PO may request additional information to support the drawdown of funding. The drawdown of funding may not commence until the additional documentation or justification is received. The PO will confirm the Recipient may complete the draw down via email.
  - An ASAP draw down can occur as frequently as needed. The Recipient shall make every effort to stay within the quarterly projections submitted to the PO through the SMART database, however, if the recipient needs to draw down more funding than previously projected, the Recipient will provide justification via email to the PO prior to initiating the ASAP draw down request.
  - The Recipient must retain documentation to support all ASAP draw downs, organized by draw down. Failure to retain the appropriate level of documentation to support the draw down may result in a determination that the reimbursement, or certain costs within the reimbursement, is/are not allowable or allocable to the federal award.
  - Approval to complete a drawdown of funding does not imply the expenditures are allowable or allocable. The GMO and/or the PO will complete progress and final financial file reviews to determine the allowable and allocable costs to the federal award. Expenditures that are determined to be unallowable or unallocable after disbursement will be deducted from the next draw down request.
  - At the completion or termination of the Agreement, unused funding shall be returned through ASAP to the BLM. This must be completed within the 120-day payment period following the performance period end date.

#### H. Payment Review

If a recipient has a history of poor performance, financial instability, uses a management system not meeting standards prescribed by the Uniform Administrative Requirements, has not conformed to the terms and conditions of the award, and/or is not otherwise responsible in safeguarding Federal funds, they may be determined to be "high risk" and be placed on Agency Review. Agency Review limits a recipient's access to funds by requiring that all draw-down requests reviewed and approved prior to their being released. Recipients on agency review must submit a completed SF-270 Request for Advance Payment or Reimbursement for each payment requested along with a detailed explanation of how the costs correspond to the approved budget categories as listed on their Application for Federal Assistance SF-424A Budget Information and their Detailed

Budget Breakdown or Challenge Cost Share Program Commitment Document, whichever is applicable. Being put on Agency Review does not relieve the recipient of required financial or performance reporting requirements.

I. System for Award Management (SAM, [www.SAM.gov](http://www.SAM.gov))

Recipients of Federal financial assistance must maintain current registration with the System for Award Management (SAM, [www.SAM.gov](http://www.SAM.gov)). Failure to maintain registration can impact access to funds and future obligations under this agreement and any other financial assistance or procurement award the recipient may have with the Federal government.

## 5. PERFORMANCE & FINANCIAL MONITORING

A. In accordance with 2 CFR §200.327 Financial Reporting and §200.328 Monitoring and Reporting Program Performance, the recipient is responsible for oversight, monitoring, and reporting of its activities under Federal awards to assure compliance with applicable Federal requirements and that performance expectations are being achieved. The BLM's monitoring of the recipient's activities may include review of the award file including discussions with the recipient regarding reporting, award activities, and project status (desk reviews), analysis of financial and performance reports, and discussions of specific issues related to project implementation, observation of project activity, and review of planned versus actual progress (site visits). The BLM has the right to inspect and evaluate the work performed or being performed under this agreement, and the premises where the work is being performed, at all reasonable times and in a manner that will not unduly delay the work. If the BLM performs inspection or evaluation on the premises of the recipient or a sub-recipient, the recipient shall furnish and shall require sub-recipients to furnish all reasonable facilities and assistance for the safe and convenient performance of these duties.

1. BLM programmatic monitoring addresses the content and substance of the program. It is a qualitative review to determine performance, innovation, and contributions to the field. The BLM may make site visits as warranted by program needs. In addition, the BLM has the right of timely and unrestricted access to any books, documents, papers, or other records of the recipient's that are pertinent to the award, in order to make audits, examinations, excerpts, transcripts, and copies of such documents. This right also includes timely and reasonable access to recipient personnel for the purpose of interviews and discussions related to such documents.
2. BLM financial monitoring ensures compliance with financial guidelines and general accounting practices. On-site or internal financial reviews are conducted to determine if: (1) award recipients are properly accounting for the receipt and expenditures of federal funds; (2) expenditures are in compliance with federal requirements and award special conditions; and (3) proper documentation on financial monitoring activities is prepared, maintained, and distributed as appropriate.



## 6. PERFORMANCE, FINANCIAL, AND OTHER REPORTING

Periodic financial, performance, and (if applicable) youth employment status reporting is a condition of this financial assistance award. Submission of reports is required whether or not any work has been attempted and/or any funds have been drawn down or expended. Failure to comply with the reporting requirements included in this agreement may be considered a material non-compliance with the terms and conditions of the award. Non-compliance may result in withholding of future payments, suspension or termination of the agreement, recovery of funds paid under the agreement, and withholding of future awards. The periodic status reporting required under this agreement is as follows.

**NOTE: Financial and Performance will be on a yearly reporting cycle for both Financial and Performance Progress Reporting is identified in the Notice of Award.**

### A. Federal Financial Reports

1. Recipients of Federal financial assistance are required to submit periodic financial reports which document the financial status of their awards. The Federal Financial Report (FFR) or SF-425 and SF-425A. Expenditures and/or income may be reported either on a cash or accrual basis, whichever method is normally used by the recipient. Submitted SF-425 reports must be signed by an authorized official of the recipient certifying that the information complete, accurate, consistent with the recipient's accounting system, and that all expenditures and obligations are for the purposes set forth in the agreement. The SF-425 represents a claim to the Federal government, filing a false claim may result in civil or criminal penalties. Blank SF-425 forms with instructions are available on the Grants.gov web site, URL: <http://www.grants.gov/web/grants/forms.html>.

### B. Performance Reports

1. Recipients of Federal financial assistance are required to submit periodic performance reports prepared in accordance with 2 CFR, Subpart D, Section 200.329 Monitoring and Reporting Program Performance. There is no standard form, however performance reports should always relate to the performance goals and objectives identified in Section 1. of this agreement. Performance reports must be submitted in a narrative summary to include, but not limited to, the following:
  - Completed established goals, work in progress, future work, the percentage of work completed (based on Section 1 of this document).
  - The reasons why established goals and objectives were not met or problems which may impact the ability to complete work on time with recommendations on their resolution, if appropriate.
  - Prediction of future activities and how they will be accomplished.
  - Where the accomplishments of the Federal award can be quantified, a computation of the cost (for example, related to units of accomplishment) may be required if that information will be useful. Where performance trend data



and analysis would be informative to the BLM program the Federal awarding agency should include this as a performance reporting requirement.

- Additional pertinent information including, when appropriate, analysis and explanation of cost overruns or high unit costs.
- Reports are to be submitted electronically within the GrantSolutions system under reporting.

2. Although the Recipient may not be required to report quarterly to the GMO on the FFR or SF-425, the Recipient must submit quarterly financial status reports in the SMART online database. The SMART online database collects status from the previous quarter and funding for the future quarter, as detailed in the table below:

Current Federal Fiscal Year (FY) Quarter	SMART Opens	SMART Closes	Quarterly Status Progress Reporting for:	ASAP Requests and Expended/Obligated for:
Q1	October 1	October 31	Q4 Previous FY (Jul-Sep)	Q2 Current FY (Jan-Mar)
Q2	January 1	January 31	Q1 Current FY (Oct-Dec)	Q3 Current FY (Apr-Jun)
Q3	April 1	April 30	Q2 Current FY (Jan-Mar)	Q4 Current FY (Jul-Sep)
Q4	July 1	July 31	Q3 Current FY (Apr-Jun)	Q1 Following FY (Oct-Dec)

The Recipient will send a transmittal letter to the SNPLMA Division, signed by the Recipient’s authorized representative, certifying the amount of projected funding, in total and per project (as necessary), being requested for draw down in the following quarter, and project compliance with the policies, procedures, and guidelines in the current SNPLMA Implementation Agreement.

3. In addition to the annual performance report required by the 2 CFR §200.328, the Recipient shall submit an annual report in the SMART online database. The annual report in SMART is a summary of the previous year’s activities. At the end of the project, the annual report serves as the final report. The final report is a summary of all major activities and accomplishments over the term of the Agreement and includes the appropriate SNPLMA performance measures.

The Recipient will send a transmittal letter to the SNPLMA Division, signed by the Recipient’s authorized representative, certifying the progress on the project in compliance with the policies, procedures, and guidelines in the current SNPLMA Implementation Agreement. This transmittal letter can be combined with the transmittal letter for financial reporting required in the previous section.

**C. Property Reporting**

1. SF-428 Tangible Personal Property Report is also required under the terms and conditions of this cooperative agreement. Tangible personal property means property of any kind, except real property, that has physical existence. It includes equipment and supplies. It does not include copyrights, patents, or securities. Property may be provided by the awarding agency or acquired by the recipient with award funds. Federally owned property consists of items that were furnished by the Federal government.

Reporting Period Dates

Submit Reports By

Award Start Date *through* September 30, 2023 .....March 31, 2024\*

\*If Federally Owned Property, report required annually. Any property acquired under this agreement; report required every two years thereafter for the life of the agreement.

D. Real Property Reporting

1. Recipients of SNPLMA funding are expected to maintain the real property acquired, constructed, or created, in the same condition or better in perpetuity, unless or until disposition instructions for the real property are issued by the GMO to the recipient. The Recipient is responsible for submitting a report on the status of real property in accordance with 2 CFR, Subpart D, §200.330 Reporting on real property.
2. The Recipient shall submit to the GMO and PO a report on real property annually for the first 3 years following completion of the project, and then every 5 years thereafter.

**7. LIABILITY, INSURANCE, AND INDEMNIFICATION**

A. Liability. The BLM assumes no liability for any actions or activities conducted under this agreement except to the extent that recourse or remedies are provided by Congress under the Federal Tort Claims Act, 28 USC 2671.

B. Indemnification. The recipient hereby agrees:

1. To indemnify the federal government, Bureau of Land Management (BLM), from any act or omission of the recipient, its officers, employees, or (members, participants, agents, representatives, agents as appropriate) (1) against third party claims for damages arising from one or more activities carried out in connection with this financial assistance agreement and (2) for damage or loss to government property resulting from such an activity, to the extent the laws of the State where the recipient is located permit. This obligation shall survive the termination of this agreement.
2. To pay the United States the full value for all damage to the lands or other property of the United States caused by the recipient, its officers, employees, or (members, participants, agents, representatives, agents as appropriate).

3. To provide workers' compensation protection to the recipient's officers, employees, and representatives.
4. To cooperate with the BLM in the investigation and defense of any claims that may be filed with the BLM arising out of the activities of the recipient, its agents, and employees.
5. In the event of damage to or destruction of the buildings and facilities assigned for the use of the recipient in whole or in part by any cause whatsoever, nothing herein contained shall be deemed to require the BLM to replace or repair the buildings or facilities. If the BLM determines in writing, after consultation with the recipient that damage to the buildings or portions thereof renders such buildings unsuitable for continued use by the recipient, the BLM shall assume sole control over such buildings or portions thereof. If the buildings or facilities rendered unsuitable for use are essential for conducting operations authorized under this agreement, then failure to substitute and assign other facilities acceptable to the recipient will constitute termination of this agreement by the BLM.

C. Flow-down. For the purposes of this clause, "recipient" includes such subrecipients, contractors, or subcontractors as, in the judgment of the recipient and subject to the Government's determination of sufficiency, have sufficient resources and/or maintain adequate and appropriate insurance to achieve the purposes of this clause.

D. Identified Activities. All activities carried out in connection with this financial assistance agreement.

## **8. BLM PROPERTY STANDARDS**

- A. Government-furnished property (GFP), such as tools and equipment, furnished by the BLM to the recipient shall be used for official purposes only and shall be subject to the terms of the agreement. Tools and equipment shall be returned in the same condition received except for normal wear and tear in project use. Any BLM property used, or other property acquired under this agreement, including intangible property such as copyrights and patents, shall be governed by the property management provisions of 2 CFR, Subpart D, §200.310 to §200.316, Property Standards.
- B. Insurance Coverage: The non-Federal entity must, at a minimum, provide the equivalent insurance coverage for real property and equipment acquired or improved with Federal funds as provided to property owned by the non-Federal entity. Refer to 2 CFR, Part 200, Subpart D, §310.
- C. Intangible Property.
  1. Title to intangible property (see §200.59 Intangible property) acquired under a Federal award vests upon acquisition in the non-Federal entity. The non-Federal entity must use that property for the originally authorized purpose and must not

- encumber the property without approval of the Federal awarding agency. When no longer needed for the originally authorized purpose, disposition of the intangible property must occur in accordance with the provisions in §200.313 Equipment paragraph (e).
2. The non-Federal entity may copyright any work that is subject to copyright and was developed, or for which ownership was acquired, under a Federal award. The Federal awarding agency reserves a royalty-free, nonexclusive, and irrevocable right to reproduce, publish, or otherwise use the work for Federal purposes, and to authorize others to do so.
  3. The non-Federal entity is subject to applicable regulations governing patents and inventions, including Governmentwide regulations issued by the Department of Commerce at 37 CFR Part 401, "Rights to Inventions Made by Nonprofit Organizations and Small Business Firms Under Government Awards, Contracts and Cooperative Agreements."
  4. The Federal government has the right to: (a) Obtain, reproduce, publish, or otherwise use the data produced under a Federal award; and (b) Authorize others to receive, reproduce, publish, or otherwise use such data for Federal purposes.
- D. Recipient staff will be required to complete a BLM-approved Defensive Driving Course if driving a Government-owned vehicle (GOV).
- E. Recipient staff will be required to complete a BLM-approved Four-wheel ATV safety and training program if using Government-furnished ATVs.
- F. Recipient staff will be required to complete a BLM-approved safety and training program if using Government-furnished power equipment, such as chainsaws, woodchippers, etc. The recipient will be responsible for meeting all protective equipment requirements if using Government-furnished equipment.

## 9. KEY OFFICIALS

The key officials on this agreement are listed on the award cover page(s) and are considered to be essential to ensure maximum coordination and communication between the parties and the work being performed. Upon written notice, either party may designate an alternate to act in the place of their designated key official.

## 10. GENERAL TERMS AND CONDITIONS

- A. See the Bureau of Land Management's ["Financial Assistance Award Terms and Conditions"](#) for the administrative and national policy requirements applicable to BLM awards.
- B. [Appendix XII to Part 200—Award Term and Condition for Recipient Integrity and Performance Matters](#)

C. Program Legislation and/or Regulations:

1. Scientific integrity is vital to Department of the Interior (DOI) activities under which scientific research, data, summaries, syntheses, interpretations, presentations, and/or publications are developed and used. Failure to uphold the highest degree of scientific integrity will result not only in potentially flawed scientific results, interpretations, and applications but will damage DOI's reputation and ability to uphold the public's trust. All work performed must comply with the DOI Scientific Integrity Policy posted to <http://www.doi.gov>, or its equivalent as provided by their organization or State law. For more information go to URL: <https://www.doi.gov/scientificintegrity>.
2. Opposition to Any Legislation. In accordance with the Department of the Interior, Environment, and Related Agencies Act, 2006, Title IV, Section 402, no part of any appropriation contained in this Act shall be available for any activity or the publication or distribution of literature that in any way tends to promote public support or opposition to any legislative proposal on which Congressional action is not complete other than to communicate to Members of Congress as described in 18 U.S.C. 1913.
3. Prohibition on Issuing Financial Assistance Awards to Entities that Require Certain Internal Confidentiality Agreements.

Section 743 of Division E, Title VII of the Consolidated and Further Continuing Resolution Appropriations Act of 2015 (Pub. L. 113-235) prohibits the use of funds appropriated or otherwise made available under that or any other Act for grants or cooperative agreements to an entity that requires employees or contractors of such entity seeking to report fraud, waste, or abuse to sign internal confidentiality agreements or statements prohibiting or otherwise restricting such employees or contractors from lawfully reporting such waste, fraud, or abuse to a designated investigative or law enforcement representative of a federal department or agency authorized to receive such information.

Recipients must not require their employees or contractors seeking to report fraud, waste, or abuse to sign internal confidentiality agreements or statements prohibiting or otherwise restricting such employees or contractors from lawfully reporting such waste, fraud, or abuse to a designated investigative or law enforcement representative of a federal department or agency authorized to receive such information.

Recipients must notify their employees or contractors that existing internal confidentiality agreements covered by this condition are no longer in effect.

4. Order of Precedence. Any inconsistency in this agreement shall be resolved by giving precedence in the following order: (a) Any national policy requirements and administrative management standards; (b) 2 CFR. Part 200; (c) requirements of the applicable OMB Circulars and Treasury regulations; (d) special terms and conditions; (e) all agreement sections, documents, exhibits, and attachments; and (f) the recipient's project proposal.

**F. 2 CFR §1402.315 Availability of data**

- (a) All data, methodology, factual inputs, models, analyses, technical information, reports, conclusions, valuation products or other scientific assessments in any medium or form, including textual, numerical, graphic, cartographic, narrative, or audiovisual, resulting from a financial assistance agreement is available for use by the Department of the Interior, including being available in a manner that is sufficient for independent verification.
- (b) The Federal Government has the right to:
  - (1) Obtain, reproduce, publish, or otherwise use the data, methodology, factual inputs, models, analyses, technical information, reports, conclusions, or other scientific assessments, produced under a Federal award; and
  - (2) Authorize others to receive, reproduce, publish, or otherwise use such data, methodology, factual inputs, models, analyses, technical information, reports, conclusions, or other scientific assessments, for Federal purposes, including to allow for meaningful third-party evaluation.

**11. SPECIAL TERMS AND CONDITIONS**

- A. **Deposit of Publications.** In addition to any requirements listed in the Project Management Plan, two (2) copies of each applicable publication produced under this agreement shall be sent to the Natural Resources Library with a transmittal that identifies the sender and the publication, and states that the publication is intended for deposit in the Natural Resources Library. Publications shall be sent to the following address:
  - U.S. Department of the Interior
  - Natural Resources Library
  - Interior Service Center
  - Gifts and Exchanges Section
  - 1849 C Street, N.W.
  - Washington, D.C. 20240
- B. **Buy America Domestic Procurement Preference:** As required by Section 70914 of the Bipartisan Infrastructure Law (also known as the Infrastructure Investment and Jobs Act), P.L. 117-58, on or after May 14, 2022, none of the funds under a federal award that are part of Federal financial assistance program for infrastructure may be obligated for a project unless all of the iron, steel, manufactured products, and construction materials used in the project are produced in the United States, unless subject to an approved waiver. The requirements of this section must be included in all subawards, including all contracts and purchase orders for work or products under this program. Recipients of an award of Federal financial assistance are hereby notified that none of the funds provided under this award may be used for a project for infrastructure unless:
  - 1. all iron and steel used in the project are produced in the United States--this means all manufacturing processes, from the initial melting stage through the application of coatings, occurred in the United States;

2. all manufactured products used in the project are produced in the United States—this means the manufactured product was manufactured in the United States; and the cost of the components of the manufactured product that are mined, produced, or manufactured in the United States is greater than 55 percent of the total cost of all components of the manufactured product, unless another standard for determining the minimum amount of domestic content of the manufactured product has been established under applicable law or regulation; and
3. all construction materials are manufactured in the United States—this means that all manufacturing processes for the construction material occurred in the United States.

The Buy America preference only applies to articles, materials, and supplies that are consumed in, incorporated into, or affixed to an infrastructure project. As such, it does not apply to tools, equipment, and supplies, such as temporary scaffolding, brought to the construction site and removed at or before the completion of the infrastructure project. Nor does a Buy America preference apply to equipment and furnishings, such as movable chairs, desks, and portable computer equipment, that are used at or within the finished infrastructure project but are not an integral part of the structure or permanently affixed to the infrastructure project.

For further information on the Buy America preference, please visit [www.doi.gov/grants/BuyAmerica](http://www.doi.gov/grants/BuyAmerica). Additional information can also be found at the White House Made in America Office website: [www.whitehouse.gov/omb/management/made-in-america/](http://www.whitehouse.gov/omb/management/made-in-america/).

### *Waivers*

When necessary, recipients may apply for, and the DOI may grant, a waiver from these requirements, subject to review by the Made in America Office. The DOI may waive the application of the domestic content procurement preference in any case in which it is determined that one of the below circumstances applies:

1. Non-availability Waiver: the types of iron, steel, manufactured products, or construction materials are not produced in the United States in sufficient and reasonably available quantities or of a satisfactory quality;
2. Unreasonable Cost Waiver: the inclusion of iron, steel, manufactured products, or construction materials produced in the United States will increase the cost of the overall project by more than 25 percent; or
3. Public Interest Waiver: applying the domestic content procurement preference would be inconsistent with the public interest.

There may be instances where an award qualifies, in whole or in part, for an existing DOI general applicability waiver as described at:

[www.doi.gov/grants/BuyAmerica/GeneralApplicabilityWaivers](http://www.doi.gov/grants/BuyAmerica/GeneralApplicabilityWaivers). If the specific financial assistance agreement, infrastructure project, or non-domestic materials meets the criteria of an existing general applicability waiver within the limitations defined within the

waiver, the recipient is not required to request a separate waiver for non-domestic materials.

If a general applicability waiver does not already apply, and a recipient believes that one of the above circumstances applies to an award, a request to waive the application of the domestic content procurement preference may be submitted to the financial assistance awarding officer in writing. Waiver requests shall include the below information. The waiver shall not include any Privacy Act information, sensitive data, or proprietary information within their waiver request. Waiver requests will be posted to [www.doi.gov/grants/buyamerica](http://www.doi.gov/grants/buyamerica) and are subject to public comment periods of no less than 15 days. Waiver requests will also be reviewed by the Made in America Office.

1. Type of waiver requested (non-availability, unreasonable cost, or public interest).
2. Requesting entity and Unique Entity Identifier (UEI) submitting the request.
3. Department of Interior Bureau or Office who issued the award.
4. Federal financial assistance listing name and number (reference block 2 on DOI Notice of Award)
5. Financial assistance title of project (reference block 8 on DOI Notice of Award).
6. Federal Award Identification Number (FAIN).
7. Federal funding amount (reference block 11.m. on DOI Notice of Award).
8. Total cost of Infrastructure expenditures (includes federal and non-federal funds to the extent known).
9. Infrastructure project description(s) and location(s) (to the extent known).
10. List of iron or steel item(s), manufactured goods, and construction material(s) the recipient seeks to waive from Buy America requirements. Include the name, cost, countries of origin (if known), and relevant PSC or NAICS code for each.
11. A certification that the recipient made a good faith effort to solicit bids for domestic products supported by terms included in requests for proposals, contracts, and nonproprietary communications with the prime contractor.
12. A statement of waiver justification, including a description of efforts made (e.g., market research, industry outreach) by the recipient, in an attempt to avoid the need for a waiver. Such a justification may cite, if applicable, the absence of any Buy America-compliant bids received in response to a solicitation.
13. Anticipated impact if no waiver is issued.

Approved waivers will be posted at [www.doi.gov/grants/BuyAmerica/ApprovedWaivers](http://www.doi.gov/grants/BuyAmerica/ApprovedWaivers); recipients requesting a waiver will be notified of their waiver request determination by an awarding officer.

Questions pertaining to waivers should be directed to the financial assistance awarding officer.

#### *Definitions*

“Construction materials” includes an article, material, or supply that is or consists primarily of:

- non-ferrous metals;



- plastic and polymer-based products (including polyvinylchloride, composite building materials, and polymers used in fiber optic cables);
- glass (including optic glass);
- lumber; or
- drywall.

“Construction Materials” does **not** include cement and cementitious materials, aggregates such as stone, sand, or gravel, or aggregate binding agents or additives.

“Domestic content procurement preference” means all iron and steel used in the project are produced in the United States; the manufactured products used in the project are produced in the United States; or the construction materials used in the project are produced in the United States.

“Infrastructure” includes, at a minimum, the structures, facilities, and equipment for, in the United States, roads, highways, and bridges; public transportation; dams, ports, harbors, and other maritime facilities; intercity passenger and freight railroads; freight and intermodal facilities; airports; water systems, including drinking water and wastewater systems; electrical transmission facilities and systems; utilities; broadband infrastructure; and buildings and real property. Infrastructure includes facilities that generate, transport, and distribute energy.

“Project” means the construction, alteration, maintenance, or repair of infrastructure in the United States

## **12. DEFINITIONS & ACRONYMS**

**Agency Review:** If a recipient has a history of poor performance, financial instability, has a management system not meeting standards prescribed by the Uniform Administrative Requirements, has not conformed to the terms and conditions of the award, and/or is not otherwise responsible in safeguarding federal funds, they may be placed on Agency Review. Agency Review limits a recipient's access to funds by requiring that all payments must be requested, reviewed, and approved prior to their being released.

**Award Recipient:** The Award Recipient is the recipient's individual who is authorized to act for the applicant and to assume the obligations imposed by the Federal laws, regulations, requirements, and conditions that apply to grant applications or grant awards.

**BLM:** Bureau of Land Management may, also be referred to as Bureau.

**CFR:** Code of Federal Regulations.

**DOI:** Department of the Interior.

**FFR:** Federal Financial Report or Standard Form (SF) 425.

**Financial Assistance Agreement:** This grant or cooperative agreement. The term grant is defined as all Federal financial assistance that provides support or stimulation to accomplish a public purpose. Use of the term “grant” includes grants and/or cooperative agreements awarded by the Federal Government to eligible recipients.

**Federal Award Date:** The date when the Federal award is sign by the BLM Grants Management Officer

**FY:** Federal Fiscal Year which runs from October 1 through September 30 each year.

**GMO:** Grants Management Officer, the only individual in the BLM who is authorized to obligate funds, award, modify, and/or terminate assistance agreements.

**GMS:** Grants Management Specialist, the administrative individual authorized to prepare assistance agreement awards and modifications, but who cannot obligate funds, award, modify, and/or terminate the agreement.

**Nomination:** Means the Recipient’s proposal for SNPLMA funding. The term “nomination” is used synonymously and interchangeably with the term “project.”

**NHPA:** National Historic Preservation Act

**NTE:** Not-to-exceed amount, the maximum Federal funding amount available for reimbursement to the recipient.

**OMB:** The Office of Management and Budget. OMB leads development of government-wide policy to assure that grants are managed properly and that Federal dollars are spent in accordance with applicable laws and regulations. OMB Circulars that apply to this agreement may be found on the OMB Website, URL:  
[http://www.whitehouse.gov/omb/circulars\\_default/](http://www.whitehouse.gov/omb/circulars_default/)[http://www.whitehouse.gov/omb/circulars\\_default/](http://www.whitehouse.gov/omb/circulars_default/)

**PI:** The BLM Project Inspector, the technical advisor assisting the BLM Program Officer in administering and monitoring the technical aspects of the agreement. The Project Inspector is not authorized to modify this agreement or obligate the Government in any way.

**PO:** The BLM Program Officer, appointed for the purposes of monitoring the technical aspects of the agreement. The PO will work closely with the RPM and is authorized to clarify technical requirements, and review and approve work which is clearly within the objectives specified in this agreement. The PO will review financial, performance, and youth employment reports, and review and recommend approval of payments to the GMO if a recipient is on Agency Review. The PO is not authorized to modify this agreement or obligate the Government in any way.

**Recipient:** The organization and/or individual named in Box 5. of the "Grant and Cooperative Agreement" cover sheet.

RPM: The recipient's Project or Program Manager, designated to direct the project or activity being supported by the agreement. The RPM is responsible and accountable to the recipient and BLM for the proper implementation of the project or activity.

SMART: Stands for the "SNPLMA Management and Reporting Tool." SMART is an online database accessible through [www.blm.gov/snplma](http://www.blm.gov/snplma) and is the required platform to complete the work plan, reimbursement requests (aka forecasting drawdowns to occur through ASAP), and all reporting requirements of the SNPLMA Implementation Agreement.

SNPLMA: The Southern Nevada Public Land Management Act of 1998 (SNPLMA), Public Law 105-263, as amended. SNPLMA authorizes the Secretary of the Interior to expend funds from the SNPLMA Special Account for the development of parks, trails, and natural areas in Clark, Lincoln, and White Pine Counties, and Carson City in Nevada (subject to limitations); development and implementation of multi-species habitat conservation plan in Clark County, Nevada; and development and implementation of comprehensive, cost-effective, multi-jurisdictional hazardous fuels reduction and wildfire prevention projects for the Lake Tahoe Basin, the Carson Range in Douglas and Washoe Counties and Carson City in Nevada, and the Spring Mountains in southern Nevada (subject to limitations).

SNPLMA Implementation Agreement: The SNPLMA Implementation Agreement is a document that contains the business rules necessary for the nomination, approval, implementation, modification, closeout, reporting, and compliance with all SNPLMA-funded projects or nominations. The SNPLMA Implementation Agreement is accessible online through [www.blm.gov/snplma](http://www.blm.gov/snplma).

### **13. FULL TEXT TERMS AND CONDITIONS**

#### **1. Department of Interior Conflict of Interest Term and Condition:**

- a. The Recipient must establish safeguards to prohibit its employees and Subrecipients from using their positions for purposes that constitute or present the appearance of a personal or organizational conflict of interest. The Recipient is responsible for notifying the Grants Officer in writing of any actual or potential conflicts of interest that may arise during the life of this award. Conflicts of interest include any relationship or matter which might place the Recipient or its employees in a position of conflict, real or apparent, between their responsibilities under the agreement and any other outside interests. Conflicts of interest may also include, but are not limited to, direct or indirect financial interests, close personal relationships, positions of trust in outside organizations, consideration of future employment arrangements with a different organization, or decision-making affecting the award that would cause a reasonable person with knowledge of the relevant facts to question the impartiality of the Recipient and/or Recipient's employees and Sub-recipients in the matter.
- b. The Grants Officer and the servicing Ethics Counselor will determine if a conflict of interest exists. If a conflict of interest exists, the Grants Officer will determine whether a mitigation plan is feasible. Mitigation plans must be approved by the Grants Officer

in writing. Failure to resolve conflicts of interest in a manner that satisfies the government may be cause for termination of the award.

- c. Failure to make required disclosures may result in any of the remedies described in 2 CFR §200.338, Remedies for Noncompliance, including suspension or debarment (see also 2 CFR Part 180).
- d. Definitions:
  - (1) Conflict of Interest is defined as any relationship or matter which might place the Recipient, its employees, and/or its Subrecipients in a position of conflict, real or apparent, between their responsibilities under the agreement and any other outside interests. Conflicts of interest may also include, but are not limited to, direct or indirect financial interests, close personal relationships, positions of trust in outside organizations, consideration of future employment arrangements with a different organization, or decision-making affecting the award that would cause a reasonable person with knowledge of the relevant facts to question the impartiality of the Recipient and/or Recipient's employees and Subrecipients in the matter.
  - (2) Close Personal Relationship means a Federal award program employee's childhood or other friend, sibling, or other family relations that may compromise or impair the fairness and impartiality of the Proposal Evaluator and Advisor and Grants Officer in the review, selection, award, and management of a financial assistance award.
  - (3) Discretionary Federal Financial Assistance means Federal awards including grants and agreements that are awarded at the discretion of the agency.
  - (4) Employment means:
    - (a) In any capacity, even if otherwise permissible, by any applicant or potential applicant for a Federal financial assistance award;
    - (b) Employment within the last 12 months with a different organization applying for some portion of the award's approved project activities and funding to complete them OR expected to apply for and to receive some portion of the award; and/or
    - (c) Employment with a different organization of any member of the organization employee's household or a relative with whom the organization's employee has a close personal relationship who is applying for some portion of the award's approved project activities and funding to complete them OR expected to apply for and to receive some portion of the award.
    - (d) Non-Federal entity means a State, local government, Indian tribe, institution of higher education, or nonprofit organization that carries out a Federal award as a Recipient or Subrecipient.
    - (e) Recipient means a non-Federal entity that receives a Federal award directly from a Federal awarding agency to carry out an activity under a Federal program. The term Recipient does not include Subrecipients.
    - (f) Subrecipient means a non-Federal entity that receives a subaward from a pass-through entity to carry out part of a Federal program but does not include an individual who is a beneficiary of such program. A Subrecipient may also be a recipient of other Federal awards directly from a Federal awarding agency.

**4. MINIMUM WAGES UNDER EXECUTIVE ORDER 13658 (January 2015)**

## (a) Definitions. As used in this clause—

“United States” means the 50 states and the District of Columbia.

“Worker”—

- (1) Means any person engaged in performing work on, or in connection with, a contract covered by Executive Order 13658, and
  - (i) Whose wages under such contract are governed by the Fair Labor Standards Act (29 U.S.C. chapter 8), the Service Contract Labor Standards statute (41 U.S.C. chapter 67), or the Wage Rate Requirements (Construction) statute (40 U.S.C. chapter 31, subchapter IV),
  - (ii) Other than individuals employed in a bona fide executive, administrative, or professional capacity, as those terms are defined in 29 CFR Part 541,
  - (iii) Regardless of the contractual relationship alleged to exist between the individual and the employer.
- (2) Includes workers performing on, or in connection with, the contract whose wages are calculated pursuant to special certificates issued under 29 U.S.C. 214(c).
- (3) Also includes any person working on, or in connection with, the contract and individually registered in a bona fide apprenticeship or training program registered with the Department of Labor's Employment and Training Administration, Office of Apprenticeship, or with a State Apprenticeship Agency recognized by the Office of Apprenticeship.

## (b) Executive Order Minimum Wage rate.

- (1) The Contractor shall pay to workers, while performing in the United States, and performing on, or in connection with, this contract, a minimum hourly wage rate of \$10.10 per hour beginning January 1, 2015.
- (2) The Contractor shall adjust the minimum wage paid, if necessary, beginning wage. The Administrator of the Department of Labor's Wage and Hour Division (the Administrator) will publish annual determinations in the Federal Register no later than 90 days before the effective date of the new E.O. minimum wage rate. The Administrator will also publish the applicable E.O. minimum wage on [www.wdol.gov](http://www.wdol.gov) (or any successor Web site) and on all wage determinations issued under the Service Contract Labor Standards statute or the Wage Rate Requirements (Construction) statute. The applicable published E.O. minimum wage is incorporated by reference into this contract.
- (3)
  - (i) The Contractor may request a price adjustment only after the effective date of the new annual E.O. minimum wage determination. Prices will be adjusted only if labor costs increase as a result of an increase in the annual E.O. minimum wage, and for associated labor costs and relevant subcontract costs. Associated labor costs shall include increases or decreases that result from changes in social security and unemployment taxes and workers' compensation insurance but will not otherwise include any amount for general and administrative costs, overhead, or profit.
  - (ii) Subcontractors may be entitled to adjustments due to the new minimum wage, pursuant to paragraph (b)(2). Contractors shall consider any subcontractor requests for such price adjustment.

- 
- (iii) The Contracting Officer will not adjust the contract price under this clause for any costs other than those identified in paragraph (b)(3)(i) of this clause and will not provide duplicate price adjustments with any price adjustment under clauses implementing the Service Contract Labor Standards statute or the Wage Rate Requirements (Construction) statute.
- (4) The Contractor warrants that the prices in this contract do not include allowance for any contingency to cover increased costs for which adjustment is provided under this clause.
- (5) A pay period under this clause may not be longer than semi-monthly but may be shorter to comply with any applicable law or other requirement under this contract establishing a shorter pay period. Workers shall be paid no later than one pay period following the end of the regular pay period in which such wages were earned or accrued.
- (6) The Contractor shall pay, unconditionally to each worker, all wages due free and clear without subsequent rebate or kickback. The Contractor may make deductions that reduce a worker's wages below the E.O. minimum wage rate only if done in accordance with 29 CFR §10.23, Deductions.
- (7) The Contractor shall not discharge any part of its minimum wage obligation under this clause by furnishing fringe benefits or, with respect to workers whose wages are governed by the Service Contract Labor Standards statute, the cash equivalent thereof.
- (8) Nothing in this clause shall excuse the Contractor from compliance with any applicable Federal or State prevailing wage law or any applicable law or municipal ordinance establishing a minimum wage higher than the E.O. minimum wage. However, wage increases under such other laws or municipal ordinances are not subject to price adjustment under this subpart.
- (9) The Contractor shall pay the E.O. minimum wage rate whenever it is higher than any applicable collective bargaining agreement(s) wage rate.
- (10) The Contractor shall follow the policies and procedures in 29 CFR §10.24(b) and 10.28 for treatment of workers engaged in an occupation in which they customarily and regularly receive more than \$30 a month in tips.
- (c) (1) This clause applies to workers as defined in paragraph (a). As provided in that definition—
- (i) Workers are covered regardless of the contractual relationship alleged to exist between the contractor or subcontractor and the worker;
  - (ii) Workers with disabilities whose wages are calculated pursuant to special certificates issued under 29 U.S.C. 214(c) are covered; and
  - (iii) Workers who are registered in a bona fide apprenticeship program or training program registered with the Department of Labor's Employment and Training Administration, Office of Apprenticeship, or with a State Apprenticeship Agency recognized by the Office of Apprenticeship, are covered.
- (2) This clause does not apply to—
- (i) Fair Labor Standards Act (FLSA)-covered individuals performing in connection with contracts covered by the E.O., i.e., those individuals who perform duties necessary to the performance of the contract, but who are not directly engaged in performing the specific work called for by the contract, and

who spend less than 20 percent of their hours worked in a particular workweek performing in connection with such contracts;

- (ii) Individuals exempted from the minimum wage requirements of the FLSA under 29 U.S.C. 213(a) and 214(a) and (b), unless otherwise covered by the Service Contract Labor Standards statute, or the Wage Rate Requirements (Construction) statute. These individuals include but are not limited to—
  - (a) Learners, apprentices, or messengers whose wages are calculated pursuant to special certificates issued under 29 U.S.C. 214(a).
  - (b) Students whose wages are calculated pursuant to special certificates issued under 29 U.S.C. 214(b).
  - (c) Those employed in a bona fide executive, administrative, or professional capacity (29 U.S.C. 213(a)(1) and 29 CFR Part 541).
  - (d) Notice. The Contractor shall notify all workers performing work on, or in connection with, this contract of the applicable E.O. minimum wage rate under this clause. With respect to workers covered by the Service Contract Labor Standards statute or the Wage Rate Requirements (Construction) statute, the Contractor may meet this requirement by posting, in a prominent and accessible place at the worksite, the applicable wage determination under those statutes. With respect to workers whose wages are governed by the FLSA, the Contractor shall post notice, utilizing the poster provided by the Administrator, which can be obtained at [www.dol.gov/whd/govcontracts](http://www.dol.gov/whd/govcontracts), in a prominent and accessible place at the worksite. Contractors that customarily post notices to workers electronically may post the notice electronically provided the electronic posting is displayed prominently on any Web site that is maintained by the contractor, whether external or internal, and customarily used for notices to workers about terms and conditions of employment.
  - (e) Payroll Records.
    - (1) The Contractor shall make and maintain records, for three years after completion of the work, containing the following information for each worker:
      - (i) Name, address, and social security number;
      - (ii) The worker's occupation(s) or classification(s);
      - (iii) The rate or rates of wages paid;
      - (iv) The number of daily and weekly hours worked by each worker;
      - (v) Any deductions made; and
      - (vi) Total wages paid.
    - (2) The Contractor shall make records pursuant to paragraph (e)(1) of this clause available for inspection and transcription by authorized representatives of the Administrator. The Contractor shall also make such records available upon request of the Contracting Officer.
    - (3) The Contractor shall make a copy of the contract available, as applicable, for inspection or transcription by authorized representatives of the Administrator.
    - (4) Failure to comply with this paragraph (e) shall be a violation of 29 CFR §10.26 and this contract. Upon direction of the Administrator or

- upon the Contracting Officer's own action, payment shall be withheld until such time as the noncompliance is corrected.
- (5) Nothing in this clause limits or otherwise modifies the Contractor's payroll and recordkeeping obligations, if any, under the Service Contract Labor Standards statute, the Wage Rate Requirements (Construction) statute, the Fair Labor Standards Act, or any other applicable law.
- (f) Access. The Contractor shall permit authorized representatives of the Administrator to conduct investigations, including interviewing workers at the worksite during normal working hours.
- (g) Withholding. The Contracting Officer, upon his or her own action or upon written request of the Administrator, will withhold funds or cause funds to be withheld from the Contractor under this or any other Federal contract with the same Contractor, sufficient to pay workers the full amount of wages required by this clause.
- (h) Disputes. Department of Labor has set forth in 29 CFR §10.51, Disputes concerning contractor compliance, the procedures for resolving disputes concerning a contractor's compliance with Department of Labor regulations at 29 CFR Part 10. Such disputes shall be resolved in accordance with those procedures and not the Disputes clause of this contract. These disputes include disputes between the Contractor (or any of its subcontractors) and the contracting agency, the Department of Labor, or the workers or their representatives.
- (i) Anti-retaliation. The Contractor shall not discharge or in any other manner discriminate against any worker because such worker has filed any complaint or instituted or caused to be instituted any proceeding under or related to compliance with the E.O. or this clause or has testified or is about to testify in any such proceeding.
- (j) Subcontractor compliance. The Contractor is responsible for subcontractor compliance with the requirements of this clause and may be held liable for unpaid wages due subcontractor workers.
- (k) Subcontracts. The Contractor shall include the substance of this clause, including this paragraph (k) in all subcontracts, regardless of dollar value, that are subject to the Service Contract Labor Standards statute or the Wage Rate Requirements (Construction) statute, and are to be performed in whole or in part in the United States.

***END OF AGREEMENT***





## STAFF REPORT

**Report To:** Board of Supervisors      **Meeting Date:** March 2, 2023

**Staff Contact:** Darren Schulz, Public Works Director

**Agenda Title:** For Possible Action: Discussion and possible action to adopt, on second reading, Bill No. 103, a proposed ordinance revising rates and fees for use of the Carson City sanitary landfill. (Darren Schulz, dschulz@carson.org, Rick Cooley, rcooley@carson.org)

**Staff Summary:** The proposed ordinance, if enacted, would increase the rates and fees charged for use of the Carson City sanitary landfill ("Landfill"), subject to certain exceptions.

**Agenda Action:** Ordinance - Second Reading      **Time Requested:** 10 minutes

---

### Proposed Motion

I move to adopt, on second reading, Bill No. 103, Ordinance No. 2023 - \_\_\_\_\_.

### Board's Strategic Goal

Sustainable Infrastructure

### Previous Action

February 2, 2023 (Item 23A): The Board of Supervisors ("Board") approved a Business Impact Statement for rate and fee increases and introduced Bill No. 103 on first reading, with instructions on additional amendments related to how Landfill charges would apply to the City's solid waste disposal franchisee.

December 1, 2022 (Item 18A): The Board instructed City staff to initiate the process to increase rates and fees for use of the Landfill, with an emphasis on meeting financial goals while minimizing impacts on City residents.

July 18, 2013 (Item 18): The Board approved changes to how certain wastes are classified and reduced out-of-county rates for Class III (Inert) waste.

October 20, 2011 (Item 12): The Board approved lowering the fees for out-of-county Class III waste.

September 1, 2011 (Item 20A): The Board approved consolidating and modifying rate classes and increasing in-county and out-of-county rates for compacted and uncompact municipal solid waste ("MSW") and Class III waste.

April 3, 2008 (Item 5): The Board approved an increase in Landfill fees by increasing out-of-county rates 25 percent for compacted and uncompact MSW and Class III waste, increasing in-county tonnage rates for compacted and uncompact MSW and Class III waste by 4.82 percent and increasing minimums by \$1.00.

### Background/Issues & Analysis

The Landfill's existing rates are below market averages, and additional revenue is necessary to ensure the Landfill's rate structure can support future Landfill needs while also continuing to support the City's general fund.

At the Board's December 1, 2022, meeting, the Board directed staff to modify proposed changes to the Landfill's fee structure such that the City could still meet the funding needs identified by staff while also minimizing the impact of increased Landfill fees on City residents. Based on that input, City staff prepared a proposed ordinance with smaller rate increases for City residents and higher increases for out-of-county users.

That proposed ordinance was introduced on first reading, as Bill No. 103, at the Board's February 2, 2023, meeting. The Board directed additional revisions to the proposed ordinance to clarify that the City's current solid waste disposal franchisee would not be subject to rate increases for solid waste disposed of pursuant to the existing franchise agreement between the City and the franchisee, but that the franchisee would pay standard rates to dispose of waste collected outside the terms of the franchise agreement. A copy of the proposed ordinance showing the changes made by the District Attorney's Office to address the Board's direction is included as supporting material to this agenda item.

Bill No. 103 would raise rates and fees at the Landfill, effective July 1, 2023, with two exceptions. First, any entity with a Board-approved contract for alternative fees, like interlocal agreements with the Towns of Minden and Gardnerville approved by the Board on February 2, 2023, would have fees charged in accord with the Board-approved contract. Second, the ordinance maintains the current rates and charges for Landfill use for the City's exclusive waste disposal franchisee, currently Waste Management, Inc., until that franchise agreement ends.

A business impact statement was prepared and approved at the Board's February 2, 2023, meeting.

Notice that Bill No. 103 would be heard on second reading at the Board's March 2, 2023, meeting was published in the Nevada Appeal on February 8, 2023, in accordance with Section 2.110 of the Carson City Charter.

**Applicable Statute, Code, Policy, Rule or Regulation**

NRS Chapter 244: Article 2 of the Carson City Charter

**Financial Information**

**Is there a fiscal impact?** Yes

**If yes, account name/number:** General Fund, Landfill Fees - 1013980-444010

**Is it currently budgeted?** No

**Explanation of Fiscal Impact:** The proposed increases to solid waste disposal at the Carson City Landfill are anticipated to raise an approximate \$900K to \$1M in revenue per year to be used for Landfill expansion, capital projects and operating costs. The majority of the increased revenue will be generated by out-of-county users of the Landfill.

**Alternatives**

Do not approve the ordinance on second reading, modify the ordinance and/or provide alternative direction.

**Attachments:**

[Draft Ord re Landfill Rates \(Second Read\)\\_final.pdf](#)

[Draft Ord re Landfill Rates \(Second Read\)\\_edits.pdf](#)

**Board Action Taken:**

Motion: \_\_\_\_\_

1) \_\_\_\_\_

2) \_\_\_\_\_

Aye/Nay

\_\_\_\_\_

\_\_\_\_\_

\_\_\_\_\_

\_\_\_\_\_

\_\_\_\_\_

\_\_\_\_\_

(Vote Recorded By)

SUMMARY: an ordinance revising rates and fees for solid waste disposal.

BILL NO. 103

ORDINANCE No. 2023 - \_\_\_\_

AN ORDINANCE RELATING TO SOLID WASTE DISPOSAL; INCREASING RATES AND FEES FOR USE OF THE CARSON CITY SANITARY LANDFILL; AND PROVIDING OTHER MATTERS PROPERLY RELATED THERETO.

The Board of Supervisors of Carson City do ordain:

SECTION I:

That Title 12 (WATER, SEWERAGE AND DRAINAGE), Chapter 12.12 (SOLID WASTE MANAGEMENT), Section 12.12.047 (LANDFILL RATES AND FEES) is hereby amended (**bold, underlined text** is added, [~~stricken~~] text is deleted) as follows:

**12.12.047 - Landfill rates and fees. (Art. 2, § 2.220 of the Carson City Charter; NRS 244.146) [Effective through June 30, 2023]**

Solid Waste Categories	In-County Fees (1,000 lbs or greater)	In-County Minimum	Out-of-County Fees (1,000 lbs or greater)	Out-of-County Fees Minimum
MSW* Compacted	\$24.00 ton <sup>1</sup>	\$10.00	\$58.00 ton	\$30.00
MSW* Un-Compacted	\$24.00 ton	\$10.00	\$58.00 ton	\$30.00
Class III (C&D*)	\$24.00 ton	\$10.00	\$36.50 ton <sup>2</sup>	\$30.00
Wood Waste and Green Waste	\$12.00 ton	\$6.00	\$24.00 ton	\$12.00
Asbestos	\$50.00 ton	\$25.00	Not accepted	Not accepted
Medical	\$200.00 ton	\$100.00	Not accepted	Not accepted
Dead animals	\$60.00 ton	\$30.00	\$120.00 ton	\$60.00
Tires <36 inches diameter with or without rim	\$3.00 each	\$3.00 each	\$6.00 each	\$6.00 each
Tires = or >36 inches diameter with or without rim	\$20.00 each	\$20.00 each	\$40.00 each	\$40.00 each

Tires: Grader, loader, tractor, backhoe, >36 inches diameter	\$30.00 each	\$30.00 each	\$60.00 each	\$60.00 each
Immediate burial	\$40.00 ton	\$20.00	\$90.00 ton	\$40.00
Trailer units or mobile homes =>30 feet in length	\$250.00 each	\$250.00	\$500.00 each	\$500.00 each
Loader Assistance	\$35.00 occurrence	\$35.00	\$70.00 occurrence	\$70.00 occurrence

\* MSW = Municipal Solid Waste, \*C&D = Construction and Demolition

To receive Carson City residential rates, the landfill customer must show proof of residency.

To receive the Wood Waste, Green Yard Waste, or Class III (C&D) rates the loads must be comprised strictly of that material only. If the loads do not conform to this and are mixed in nature, the loads will be charged at the rate for the most expensive material. EXAMPLE: a load is predominately Class III but contains any amount of asbestos containing material, the complete load will be charged at the rate for asbestos.

<sup>1</sup> Rate shall be adjusted annually in May using the annual percentage change in the Consumer Price Index for All Urban Consumers (CPI-U) - US City Average, Garbage and Trash Collection, as published by the Bureau of Labor Statistics, Washington D.C., commencing with the index for the twelve month period ending December 31, 2012 and each percentage change annually thereafter. In no year shall the adjustment be less than zero or more than six percent (6%). The term shall coincide with the term of the Solid Waste and Recyclable Materials Franchise Agreement, Chapter 5.10 of the Carson City Municipal Code.

<sup>2</sup> Rate shall be reduced for Class III (C&D) to the In-County Fee (1,000 lbs or greater) rate for a customer when a subscription is entered into which provides for a minimum of 1000 tons per year.

SECTION II:

That Title 12 (WATER, SEWERAGE AND DRAINAGE), Chapter 12.12 (SOLID WASTE MANAGEMENT), Section 12.12.047 (LANDFILL RATES AND FEES) is hereby amended (**bold, underlined text** is added, [~~stricken~~] text is deleted) as follows:

**12.12.047 - Landfill rates and fees. (Art. 2, § 2.220 of the Carson City Charter; NRS 244.146) [Effective July 1, 2023]**

**1. Except as otherwise provided in subsection 5 and CCMC 12.12.048, the City shall collect the following base fees for the disposal of solid waste at the landfill:**

Solid Waste Categories	In-County Fees (1,000 lbs or greater)	In-County <u>Fees</u> Minimum	Out-of-County Fees (1,000 lbs or greater)	Out-of-County Fees Minimum
MSW* Compacted	<del>[\$24.00]</del> <b>\$30.00</b> per ton <sup>[+]</sup>	\$10.00	<del>[\$58.00]</del> <b>\$74.00</b> per ton	<del>[\$30.00]</del> <b>\$42.00</b>
MSW* Un-Compacted	<del>[\$24.00]</del> <b>\$30.00</b> per ton	\$10.00	<del>[\$58.00]</del> <b>\$74.00</b> per ton	<del>[\$30.00]</del> <b>\$42.00</b>
Class III (C&D**)	<del>[\$24.00]</del> <b>\$30.00</b> per ton	\$10.00	<del>[\$36.50]</del> <b>\$74.00</b> per ton <sup>[2]</sup>	<del>[\$30.00]</del> <b>\$42.00</b>
Wood Waste and Green Waste	<del>[\$12.00]</del> <b>\$16.00</b> per ton	<del>[\$6.00]</del> <b>\$8.00</b>	<del>[\$24.00]</del> <b>\$74.00</b> per ton	<del>[\$12.00]</del> <b>\$42.00</b>
Asbestos	<del>[\$50.00]</del> <b>\$63.00</b> per ton	<del>[\$25.00]</del> <b>\$31.50</b>	Not accepted	Not accepted
Medical	<del>[\$200.00]</del> <b>\$253.00</b> per ton	<del>[\$100.00]</del> <b>\$126.50</b>	Not accepted	Not accepted
Dead [animals] <b>Animals</b>	<del>[\$60.00]</del> <b>\$76.00</b> per ton	<del>[\$30.00]</del> <b>\$38.00</b>	<del>[\$120.00]</del> <b>\$152.00</b> per ton	<del>[\$60.00]</del> <b>\$76.00</b>
[Tires <36 inches diameter with or without rim	\$3.00 each	\$3.00 each	\$6.00 each	\$6.00 each
Tires = or >36 inches diameter with or without rim	\$20.00 each	\$20.00 each	\$40.00 each	\$40.00 each
Tires: Grader, loader, tractor, backhoe, >36 inches diameter	\$30.00 each	\$30.00 each	\$60.00 each	\$60.00 each
Immediate burial	\$40.00 ton	\$20.00	\$90.00 ton	\$40.00
Trailer units or mobile homes =>30 feet in length	\$250.00 each	\$250.00	\$500.00 each	\$500.00 each
Loader Assistance	\$35.00 occurrence	\$35.00	\$70.00 occurrence	\$70.00 occurrence]

\* MSW = Municipal Solid Waste[5]

\*\* C&D = Construction and Demolition

**2. Except as otherwise provided in subsection 5 and CCMC 12.12.048, in addition to the base fees set forth in subsection 1, the City shall collect the following supplemental charges, if applicable:**

<u>Solid Waste Categories</u>	<u>In-County Fees</u>	<u>In-County Fees Minimum</u>	<u>Out-of-County Fees</u>	<u>Out-of-County Fees Minimum</u>
<u>Appliances with Refrigerant</u>	<u>\$25.00 each</u>	<u>\$25.00 each</u>	<u>\$50.00 each</u>	<u>\$50.00 each</u>
<u>Tires: &lt;36” diameter with or without rim</u>	<u>\$7.00 each</u>	<u>\$7.00 each</u>	<u>\$14.00 each</u>	<u>\$14.00 each</u>
<u>Tires: = or &gt;36” diameter with or without rim</u>	<u>\$20.00 each</u>	<u>\$20.00 each</u>	<u>\$40.00 each</u>	<u>\$40.00 each</u>
<u>Tires: equipment, including, without limitation, grader, loader, tractor, backhoe</u>	<u>\$30.00 each</u>	<u>\$30.00 each</u>	<u>\$60.00 each</u>	<u>\$60.00 each</u>
<u>Immediate Burial</u>	<u>\$50.00 per ton</u>	<u>\$25.00</u>	<u>\$100.00 per ton</u>	<u>\$100.00</u>
<u>Trailer Units or Mobile Homes</u>	<u>\$315.00 each</u>	<u>\$315.00 each</u>	<u>\$630.00 each</u>	<u>\$630.00 each</u>
<u>Loader Assistance</u>	<u>\$45.00 per occurrence</u>	<u>\$45.00 per occurrence</u>	<u>\$90.00 per occurrence</u>	<u>\$90.00 per occurrence</u>

[To receive Carson City residential rates, the landfill customer must show proof of residency.]  
[To receive the Wood Waste, Green Yard Waste, or Class III (C&D) rates the loads must be comprised strictly of that material only. If the loads do not conform to this and are mixed in nature, the loads will be charged at the rate for the most expensive material. EXAMPLE: a load is predominately Class III but contains any amount of asbestos containing material, the complete load will be charged at the rate for asbestos.]

[<sup>1</sup>Rate shall be adjusted annually in May using the annual percentage change in the Consumer Price Index for All Urban Consumers (CPI-U) – US City Average, Garbage and Trash Collection, as published by the Bureau of Labor Statistics, Washington D.C., commencing with the index for the twelve month period ending December 31, 2012 and each percentage change annually thereafter. In no year shall the adjustment be less than zero or more than six percent (6%). The term shall coincide with the term of the Solid Waste and Recyclable Materials Franchise Agreement, Chapter 5.10 of the Carson City Municipal Code.]

[<sup>2</sup>Rate shall be reduced for Class III (C&D) to the In-County Fee (1,000 lbs or greater) rate for a customer when a subscription is entered into which provides for a minimum of 1000 tons per year.]

**3. A person who disposes of solid waste at the landfill must provide proof of residency in Carson City to be eligible for in-county fees set forth in this section.**

**4. For any load of waste that is:**

**(a) Comprised entirely of a single waste category described in subsection 1, the corresponding base charge applies.**

**(b) Comprised of two or more waste categories described in subsection 1, the highest corresponding base charge applies.**

**5. The base fees set forth in subsection 1 and the supplemental charges set forth in subsection 2 do not apply to any contract that is approved by the Board of Supervisors, including, without limitation, an interlocal contract entered into in accordance with NRS 277.180, that establishes different fees or charges.**

**SECTION III:**

That Title 12 (WATER, SEWERAGE AND DRAINAGE), Chapter 12.12 (SOLID WASTE MANAGEMENT) is hereby amended by adding thereto a new Section 12.12.048 (Landfill rates and fees for franchisee) (**bold, underlined text** is added, [~~stricken~~] text is deleted) as follows:

**12.12.048 – Landfill rates and fees for franchisee. (Art. 2, § 2.220 of the Carson City Charter; NRS 244.146) [Effective July 1, 2023 and expiring by limitation upon the termination of the exclusive franchise agreement approved by the Board of Supervisors on June 20, 2019, as Ordinance No. 2019-6]**

**The franchisee with whom the City has entered into an exclusive franchise agreement for the collection and disposal of solid waste shall:**

**1. If the franchisee disposes of solid waste that was not collected in Carson City or in any other manner not in accordance with the exclusive franchise agreement, pay the base fees and supplemental charges set forth in CCMC 12.12.047 for the disposal of solid waste at the landfill.**

**2. If the franchisee disposes of solid waste that was collected in Carson City and disposed of in accordance with the exclusive franchise agreement, pay the following fees and charges for the disposal of solid waste at the landfill:**

<b><u>Solid Waste Categories</u></b>	<b><u>Franchisee Fees (1,000 lbs or greater)</u></b>	<b><u>Franchisee Minimum</u></b>
<b><u>MSW Compacted</u></b>	<b><u>\$24.00 per ton</u></b>	<b><u>\$10.00</u></b>
<b><u>MSW Un-Compacted</u></b>	<b><u>\$24.00 per ton</u></b>	<b><u>\$10.00</u></b>
<b><u>Class III (C&amp;D)</u></b>	<b><u>\$24.00 per ton</u></b>	<b><u>\$10.00</u></b>
<b><u>Wood Waste and Green Waste</u></b>	<b><u>\$12.00 per ton</u></b>	<b><u>\$6.00</u></b>
<b><u>Asbestos</u></b>	<b><u>\$50.00 per ton</u></b>	<b><u>\$25.00</u></b>
<b><u>Medical</u></b>	<b><u>\$200.00 per ton</u></b>	<b><u>\$100.00</u></b>
<b><u>Dead Animals</u></b>	<b><u>\$60.00 per ton</u></b>	<b><u>\$30.00</u></b>
<b><u>Tires: &lt;36” diameter with or without rim</u></b>	<b><u>\$3.00 each</u></b>	<b><u>\$3.00 each</u></b>
<b><u>Tires: = or &gt;36” diameter with or without rim</u></b>	<b><u>\$20.00 each</u></b>	<b><u>\$20.00 each</u></b>
<b><u>Tires: equipment, including, without</u></b>	<b><u>\$30.00 each</u></b>	<b><u>\$30.00 each</u></b>



<u>limitation, grader, loader, tractor, backhoe</u>		
<u>Immediate Burial</u>	<u>\$40.00 ton</u>	<u>\$20.00</u>
<u>Trailer Units or Mobile Homes</u>	<u>\$250.00 each</u>	<u>\$250.00</u>
<u>Loader Assistance</u>	<u>\$35.00 occurrence</u>	<u>\$35.00</u>

SECTION IV:

That no other provisions of the Carson City Municipal Code are affected by this ordinance.

PROPOSED on \_\_\_\_\_, 2023.

PROPOSED by Supervisor \_\_\_\_\_.

PASSED on \_\_\_\_\_, 2023.

VOTE:        AYES:        SUPERVISORS: \_\_\_\_\_

\_\_\_\_\_

\_\_\_\_\_

\_\_\_\_\_

\_\_\_\_\_

NAYS:        SUPERVISORS: \_\_\_\_\_

\_\_\_\_\_

\_\_\_\_\_

\_\_\_\_\_  
Lori Bagwell  
Mayor

ATTEST:

\_\_\_\_\_  
William Scott Hoen  
Carson City Clerk-Recorder

This ordinance shall be in force and effect from the \_\_\_\_\_ day of the month of \_\_\_\_\_ of the year 2023.

SUMMARY: an ordinance revising rates and fees for solid waste disposal.

BILL NO. ~~103~~

ORDINANCE No. 2023 - \_\_\_\_\_

AN ORDINANCE RELATING TO SOLID WASTE DISPOSAL; INCREASING RATES AND FEES FOR USE OF THE CARSON CITY SANITARY LANDFILL; AND PROVIDING OTHER MATTERS PROPERLY RELATED THERETO.

The Board of Supervisors of Carson City do ordain:

SECTION I:

That Title 12 (WATER, SEWERAGE AND DRAINAGE), Chapter 12.12 (SOLID WASTE MANAGEMENT), Section 12.12.047 (LANDFILL RATES AND FEES) is hereby amended (**bold, underlined text** is added, [~~stricken~~] text is deleted) as follows:

**12.12.047 - Landfill rates and fees. (Art. 2, § 2.220 of the Carson City Charter; NRS 244.146) [Effective through June 30, 2023]**

Solid Waste Categories	In-County Fees (1,000 lbs or greater)	In-County Minimum	Out-of-County Fees (1,000 lbs or greater)	Out-of-County Fees Minimum
MSW* Compacted	\$24.00 ton <sup>1</sup>	\$10.00	\$58.00 ton	\$30.00
MSW* Un-Compacted	\$24.00 ton	\$10.00	\$58.00 ton	\$30.00
Class III (C&D*)	\$24.00 ton	\$10.00	\$36.50 ton <sup>2</sup>	\$30.00
Wood Waste and Green Waste	\$12.00 ton	\$6.00	\$24.00 ton	\$12.00
Asbestos	\$50.00 ton	\$25.00	Not accepted	Not accepted
Medical	\$200.00 ton	\$100.00	Not accepted	Not accepted
Dead animals	\$60.00 ton	\$30.00	\$120.00 ton	\$60.00
Tires <36 inches diameter with or without rim	\$3.00 each	\$3.00 each	\$6.00 each	\$6.00 each
Tires = or >36 inches diameter with or without rim	\$20.00 each	\$20.00 each	\$40.00 each	\$40.00 each

Tires: Grader, loader, tractor, backhoe, >36 inches diameter	\$30.00 each	\$30.00 each	\$60.00 each	\$60.00 each
Immediate burial	\$40.00 ton	\$20.00	\$90.00 ton	\$40.00
Trailer units or mobile homes =>30 feet in length	\$250.00 each	\$250.00	\$500.00 each	\$500.00 each
Loader Assistance	\$35.00 occurrence	\$35.00	\$70.00 occurrence	\$70.00 occurrence

\* MSW = Municipal Solid Waste, \*C&D = Construction and Demolition

To receive Carson City residential rates, the landfill customer must show proof of residency.

To receive the Wood Waste, Green Yard Waste, or Class III (C&D) rates the loads must be comprised strictly of that material only. If the loads do not conform to this and are mixed in nature, the loads will be charged at the rate for the most expensive material. EXAMPLE: a load is predominately Class III but contains any amount of asbestos containing material, the complete load will be charged at the rate for asbestos.

<sup>1</sup> Rate shall be adjusted annually in May using the annual percentage change in the Consumer Price Index for All Urban Consumers (CPI-U) - US City Average, Garbage and Trash Collection, as published by the Bureau of Labor Statistics, Washington D.C., commencing with the index for the twelve month period ending December 31, 2012 and each percentage change annually thereafter. In no year shall the adjustment be less than zero or more than six percent (6%). The term shall coincide with the term of the Solid Waste and Recyclable Materials Franchise Agreement, Chapter 5.10 of the Carson City Municipal Code.

<sup>2</sup> Rate shall be reduced for Class III (C&D) to the In-County Fee (1,000 lbs or greater) rate for a customer when a subscription is entered into which provides for a minimum of 1000 tons per year.

SECTION II:

That Title 12 (WATER, SEWERAGE AND DRAINAGE), Chapter 12.12 (SOLID WASTE MANAGEMENT), Section 12.12.047 (LANDFILL RATES AND FEES) is hereby amended (**bold, underlined text** is added, [~~stricken~~] text is deleted) as follows:

**12.12.047 - Landfill rates and fees. (Art. 2, § 2.220 of the Carson City Charter; NRS 244.146) [Effective July 1, 2023]**

**1. Except as otherwise provided in subsection 5 and CCMC 12.12.048, the City shall collect the following base fees for the disposal of solid waste at the landfill:**

Solid Waste Categories	In-County Fees (1,000 lbs or greater)	In-County <b>Fees</b> Minimum	Out-of-County Fees (1,000 lbs or greater)	Out-of-County Fees Minimum
MSW* Compacted	<del>[\$24.00]</del> <b>\$30.00</b> per ton <sup>[+]</sup>	\$10.00	<del>[\$58.00]</del> <b>\$74.00</b> per ton	<del>[\$30.00]</del> <b>\$42.00</b>
MSW* Un-Compacted	<del>[\$24.00]</del> <b>\$30.00</b> per ton	\$10.00	<del>[\$58.00]</del> <b>\$74.00</b> per ton	<del>[\$30.00]</del> <b>\$42.00</b>
Class III (C&D**)	<del>[\$24.00]</del> <b>\$30.00</b> per ton	\$10.00	<del>[\$36.50]</del> <b>\$74.00</b> per ton <sup>[2]</sup>	<del>[\$30.00]</del> <b>\$42.00</b>
Wood Waste and Green Waste	<del>[\$12.00]</del> <b>\$16.00</b> per ton	<del>[\$6.00]</del> <b>\$8.00</b>	<del>[\$24.00]</del> <b>\$74.00</b> per ton	<del>[\$12.00]</del> <b>\$42.00</b>
Asbestos	<del>[\$50.00]</del> <b>\$63.00</b> per ton	<del>[\$25.00]</del> <b>\$31.50</b>	Not accepted	Not accepted
Medical	<del>[\$200.00]</del> <b>\$253.00</b> per ton	<del>[\$100.00]</del> <b>\$126.50</b>	Not accepted	Not accepted
Dead [animals] <b>Animals</b>	<del>[\$60.00]</del> <b>\$76.00</b> per ton	<del>[\$30.00]</del> <b>\$38.00</b>	<del>[\$120.00]</del> <b>\$152.00</b> per ton	<del>[\$60.00]</del> <b>\$76.00</b>
[Tires <36 inches diameter with or without rim	\$3.00 each	\$3.00 each	\$6.00 each	\$6.00 each
Tires = or >36 inches diameter with or without rim	\$20.00 each	\$20.00 each	\$40.00 each	\$40.00 each
Tires: Grader, loader, tractor, backhoe, >36 inches diameter	\$30.00 each	\$30.00 each	\$60.00 each	\$60.00 each
Immediate burial	\$40.00 ton	\$20.00	\$90.00 ton	\$40.00
Trailer units or mobile homes =>30 feet in length	\$250.00 each	\$250.00	\$500.00 each	\$500.00 each
Loader Assistance	\$35.00 occurrence	\$35.00	\$70.00 occurrence	\$70.00 occurrence]

\* MSW = Municipal Solid Waste[5]

\*\* C&D = Construction and Demolition

**2. Except as otherwise provided in subsection 5 and CCMC 12.12.048, in addition to the base fees set forth in subsection 1, the City shall collect the following supplemental charges, if applicable:**

<u>Solid Waste Categories</u>	<u>In-County Fees</u>	<u>In-County Fees Minimum</u>	<u>Out-of-County Fees</u>	<u>Out-of-County Fees Minimum</u>
<u>Appliances with Refrigerant</u>	<u>\$25.00 each</u>	<u>\$25.00 each</u>	<u>\$50.00 each</u>	<u>\$50.00 each</u>
<u>Tires: &lt;36” diameter with or without rim</u>	<u>\$7.00 each</u>	<u>\$7.00 each</u>	<u>\$14.00 each</u>	<u>\$14.00 each</u>
<u>Tires: = or &gt;36” diameter with or without rim</u>	<u>\$20.00 each</u>	<u>\$20.00 each</u>	<u>\$40.00 each</u>	<u>\$40.00 each</u>
<u>Tires: equipment, including, without limitation, grader, loader, tractor, backhoe</u>	<u>\$30.00 each</u>	<u>\$30.00 each</u>	<u>\$60.00 each</u>	<u>\$60.00 each</u>
<u>Immediate Burial</u>	<u>\$50.00 per ton</u>	<u>\$25.00</u>	<u>\$100.00 per ton</u>	<u>\$100.00</u>
<u>Trailer Units or Mobile Homes</u>	<u>\$315.00 each</u>	<u>\$315.00 each</u>	<u>\$630.00 each</u>	<u>\$630.00 each</u>
<u>Loader Assistance</u>	<u>\$45.00 per occurrence</u>	<u>\$45.00 per occurrence</u>	<u>\$90.00 per occurrence</u>	<u>\$90.00 per occurrence</u>

[To receive Carson City residential rates, the landfill customer must show proof of residency.]

[To receive the Wood Waste, Green Yard Waste, or Class III (C&D) rates the loads must be comprised strictly of that material only. If the loads do not conform to this and are mixed in nature, the loads will be charged at the rate for the most expensive material. EXAMPLE: a load is predominately Class III but contains any amount of asbestos containing material, the complete load will be charged at the rate for asbestos.]

[<sup>1</sup>Rate shall be adjusted annually in May using the annual percentage change in the Consumer Price Index for All Urban Consumers (CPI-U) – US City Average, Garbage and Trash Collection, as published by the Bureau of Labor Statistics, Washington D.C., commencing with the index for the twelve month period ending December 31, 2012 and each percentage change annually thereafter. In no year shall the adjustment be less than zero or more than six percent (6%). The term shall coincide with the term of the Solid Waste and Recyclable Materials Franchise Agreement, Chapter 5.10 of the Carson City Municipal Code.]

[<sup>2</sup>Rate shall be reduced for Class III (C&D) to the In-County Fee (1,000 lbs or greater) rate for a customer when a subscription is entered into which provides for a minimum of 1000 tons per year.]

**3. A person who disposes of solid waste at the landfill must provide proof of residency in Carson City to be eligible for in-county fees set forth in this section.**

**4. For any load of waste that is:**

**(a) Comprised entirely of a single waste category described in subsection 1, the corresponding base charge applies.**

(b) Comprised of two or more waste categories described in subsection 1, the highest corresponding base charge applies.

5. The base fees set forth in subsection 1 and the supplemental charges set forth in subsection 2 do not apply to:

(a) ~~Any any~~ contract that is approved by the Board of Supervisors, including, without limitation, an interlocal contract entered into in accordance with NRS 277.180, that establishes different fees or charges.

(b) ~~Solid waste disposed of by the franchisee of the exclusive franchise agreement adopted pursuant to CCMC 5.10.010, from whom the City shall collect the following fees and charges for the disposal of solid waste at the landfill:~~

### SECTION III:

That Title 12 (WATER, SEWERAGE AND DRAINAGE), Chapter 12.12 (SOLID WASTE MANAGEMENT) is hereby amended by adding thereto a new Section 12.12.048 (Landfill rates and fees for franchisee) (bold, underlined text is added, [stricken] text is deleted) as follows:

12.12.048 – Landfill rates and fees for franchisee. (Art. 2, § 2.220 of the Carson City Charter; NRS 244.146) [Effective July 1, 2023 and expiring by limitation upon the termination of the exclusive franchise agreement approved by the Board of Supervisors on June 20, 2019, as Ordinance No. 2019-6]

The franchisee with whom the City has entered into an exclusive franchise agreement for the collection and disposal of solid waste shall:

1. If the franchisee disposes of solid waste that was not collected in Carson City or in any other manner not in accordance with the exclusive franchise agreement, pay the base fees and supplemental charges set forth in CCMC 12.12.047 for the disposal of solid waste at the landfill.

2. If the franchisee disposes of solid waste that was collected in Carson City and disposed of in accordance with the exclusive franchise agreement, pay the following fees and charges for the disposal of solid waste at the landfill:

<u>Solid Waste Categories</u>	<u>Franchisee Fees (1,000 lbs or greater)</u>	<u>Franchisee Minimum</u>
<u>MSW Compacted</u>	<u>\$24.00 per ton</u>	<u>\$10.00</u>
<u>MSW Un-Compacted</u>	<u>\$24.00 per ton</u>	<u>\$10.00</u>
<u>Class III (C&amp;D)</u>	<u>\$24.00 per ton</u>	<u>\$10.00</u>
<u>Wood Waste and Green Waste</u>	<u>\$12.00 per ton</u>	<u>\$6.00</u>
<u>Asbestos</u>	<u>\$50.00 per ton</u>	<u>\$25.00</u>
<u>Medical</u>	<u>\$200.00 per ton</u>	<u>\$100.00</u>
<u>Dead Animals</u>	<u>\$60.00 per ton</u>	<u>\$30.00</u>

<u>Tires: &lt;36” diameter with or without rim</u>	<u>\$3.00 each</u>	<u>\$3.00 each</u>
<u>Tires: = or &gt;36” diameter with or without rim</u>	<u>\$20.00 each</u>	<u>\$20.00 each</u>
<u>Tires: equipment, including, without limitation, grader, loader, tractor, backhoe</u>	<u>\$30.00 each</u>	<u>\$30.00 each</u>
<u>Immediate Burial</u>	<u>\$40.00 ton</u>	<u>\$20.00</u>
<u>Trailer Units or Mobile Homes</u>	<u>\$250.00 each</u>	<u>\$250.00</u>
<u>Loader Assistance</u>	<u>\$35.00 occurrence</u>	<u>\$35.00</u>

SECTION **HHIV**:

That no other provisions of the Carson City Municipal Code are affected by this ordinance.

PROPOSED on \_\_\_\_\_, 2023.

PROPOSED by Supervisor \_\_\_\_\_.

PASSED on \_\_\_\_\_, 2023.

VOTE:        AYES:        SUPERVISORS: \_\_\_\_\_

\_\_\_\_\_

\_\_\_\_\_

\_\_\_\_\_

\_\_\_\_\_

NAYS:        SUPERVISORS: \_\_\_\_\_

\_\_\_\_\_

\_\_\_\_\_

\_\_\_\_\_  
Lori Bagwell  
Mayor

ATTEST:

\_\_\_\_\_  
William Scott Hoen  
Carson City Clerk-Recorder

This ordinance shall be in force and effect from the \_\_\_\_\_ day of the month of \_\_\_\_\_ of the year 2023.





## STAFF REPORT

**Report To:** Board of Supervisors **Meeting Date:** March 2, 2023

**Staff Contact:** Heather Ferris, Planning Manager

**Agenda Title:** For Possible Action: Discussion and possible action regarding a request from Carson City ("Applicant") to introduce, on first reading, a proposed ordinance amending the zoning map to change the zoning from Limited Industrial ("LI") and Single-Family 1 Acre ("SF1A") to Single-Family 6,000 ("SF6") for Assessor's Parcel Number ("APN") 010-061-87; from SF1A to SF6 for the southern, approximately 4.5 acres of APN 010-061-84 addressed at 1601 Fairview Drive; and from LI to SF6 for the northern, approximately 9.7 acres of APN 010-061-76 addressed at 1700 Colorado Street. (Heather Ferris, hferris@carson.org)

**Staff Summary:** Through the annual review of the master plan and zoning map, the Board of Supervisors ("Board") and staff have identified the subject parcels as appropriate for consideration of mapping corrections. The proposed zoning map amendment will create consistency with the underlying master plan for the subject parcels. The parcels are located south of Fairview Drive, north of Colorado Street, and east of S. Saliman Road. Pursuant to Nevada Revised Statutes ("NRS") Chapter 237, a business impact statement is not required to be prepared with this ordinance.

**Agenda Action:** Ordinance - First Reading **Time Requested:** 15 minutes

---

### **Proposed Motion**

I move to introduce, on first reading, Bill No. \_\_\_\_\_.

### **Board's Strategic Goal**

Quality of Life

### **Previous Action**

January 25, 2023 (Item 6F): The Planning Commission recommended approval by a vote of 7 - 0, 0 absent, 0 abstention.

December 20, 2022 (Items 14F, 14H and 14J): The Planning Commission considered three separate master plan amendments and zoning map amendments for the subject parcels. Following discussion, at the meeting, the Commission continued the items to the January 25, 2023, meeting.

### **Background/Issues & Analysis**

At its meeting of December 15, 2021, the Planning Commission was provided with an update on the master plan implementation activities and reviewed and made a recommendation to the Board on the Master Plan Action Plan and other master plan related matters. At its meeting of January 20, 2022, the Board accepted the 2021 Master Plan report from the Planning Commission and identified the subject parcels as appropriate for consideration of a mapping correction.

The Planning Commission considered three separate master plan amendments and zoning map amendments for the subject parcels at their December 20, 2022, meeting; however, following discussion at the meeting, the Commission continued the items to the January 25, 2023, meeting.

The subject parcels are in an area with a mix of uses including residential, warehousing, personal storage, office space and retail.

APN 010-061-87 is located at the northeast corner of S. Saliman Road and Colorado Street. The parcel is currently vacant and has a split master plan designation of MUC and MDR and split zoning of LI and SF1A. The zoning and master plan are not consistent with one another.

APN 010-061-84 is located at 1601 Fairview Drive. The parcel is currently developed with office, warehouse and storage uses. There is a split master plan designation of MUC and MDR and a split zoning of LI and SF1A. The zoning and master plan are not consistent with one another.

APN 010-061-76 is located at 1700 Colorado and is developed with a manufactured home park. The master plan designation is MDR and there is a split zoning of LI and SF6. The existing zoning and master plan are not consistent with one another nor are they consistent with the existing use of a manufactured home park. The manufactured home park was approved in 1985. At that time the property was zoned LI and SF6 as well and the zoning code allowed for a mobile home park in these zoning districts subject to a special use permit. Since that time, the zoning code has changed making this a non-conforming use.

During the January 25, 2023 Planning Commission meeting, the Planning Commission considered a master plan amendment along with a zoning map amendment to Mixed Use Commercial and General Commercial across all three parcels. However, after hearing from members of the public regarding concerns with increased traffic from additional commercial uses in the area, the Planning Commission determined that the existing master plan designations make sense for the area and recommended no change to the master plan. Additionally, because the Planning Commission did not recommend a change to the master plan, the Planning Commission recommended zoning for each parcel consistent with the existing underlying master plan.

The Planning Commission recommended the following zoning map amendment:

- From LI and SF1A to SF6 for APN 010-061-87 located at the northeast corner of S. Saliman Road and Colorado Street;
- From SF1A to SF6 for the southern, approximately 4.5 acres of APN 010-061-84 addressed at 1601 Fairview Drive; and
- From LI to SF6 for the northern, approximately 9.7 acres of APN 010-061-76 addressed at 1700 Colorado Street.

**Applicable Statute, Code, Policy, Rule or Regulation**

NRS Chapter 244; Article 2 of the Carson City Charter; CCMC 18.02.075

**Financial Information**

**Is there a fiscal impact?** No

**If yes, account name/number:**

**Is it currently budgeted?** No

**Explanation of Fiscal Impact:**

**Alternatives**

Do not introduce the ordinance and/or provide alternative direction to staff.

**Attachments:**

[ZA-2023-0008 Ord.- DRAFT clean.doc](#)

[PC Staff Report with Supporting Material.pdf](#)

[DRAFT 01-25-2023 Minutes \(PC\) \(excerpt\).pdf](#)

**Board Action Taken:**

Motion: \_\_\_\_\_ 1) \_\_\_\_\_  
2) \_\_\_\_\_

Aye/Nay  
\_\_\_\_\_  
\_\_\_\_\_  
\_\_\_\_\_  
\_\_\_\_\_

\_\_\_\_\_  
(Vote Recorded By)

SUMMARY – Amends the Carson City zoning map.

BILL NO. \_\_\_\_\_  
ORDINANCE NO. 2023-\_\_

AN ORDINANCE RELATING TO ZONING; ESTABLISHING VARIOUS PROVISIONS TO CHANGE THE ZONING FROM LIMITED INDUSTRIAL (“LI”) AND SINGLE-FAMILY 1 ACRE (“SF1A”) TO SINGLE-FAMILY 6,000 (“SF6”) FOR ASSESSOR’S PARCEL NUMBER (“APN”) 010-061-87 LOCATED ON THE NORTHEAST CORNER OF S. SALIMAN ROAD AND COLORADO STREET; FROM SINGLE-FAMILY 1 ACRE (“SF1A”) TO SINGLE-FAMILY 6,000 (“SF6”) FOR THE SOUTHERN, APPROXIMATELY 4.5 ACRES OF APN 010-061-84 ADDRESSED AT 1601 FAIRVIEW DRIVE; AND FROM LIMITED INDUSTRIAL (“LI”) TO SINGLE-FAMILY 6,000 (“SF6”) FOR THE NORTHERN, APPROXIMATELY 9.7 ACRES OF APN 010-061-76 ADDRESSED AT 1700 COLORADO STREET.

The Board of Supervisors of Carson City do ordain:

SECTION I:

An application for a zoning map amendment affecting Assessor’s Parcel Numbers (“APNs”) 010-061-76; 010-061-84; and 010-061-87, located south of Fairview Drive, north of Colorado Street, and east of S. Saliman Road, Carson City, Nevada, was duly submitted to the Planning Division of the Carson City Community Development Department in accordance with section 18.02.075 of the Carson City Municipal Code (“CCMC”) to revise the existing zoning designations from Limited Industrial (“LI”) and Single-Family 1 Acre (“SF1A”) to Single-Family 6,000 (“SF6”) for Assessor’s Parcel Number (“APN”) 010-061-87; from Single-Family 1 Acre (“SF1A”) to Single-Family 6,000 (“SF6”) for the southern, approximately 4.5 acres of APN 010-061-84 addressed at 1601 Fairview Drive; and from Limited Industrial (“LI”) to Single-Family 6,000 (“SF6”) for the northern, approximately 9.7 acres of APN 010-061-76 addressed at 1700 Colorado Street. After proper noticing in accordance with Chapter 278 of the Nevada Revised Statutes and CCMC Title 18, on January 25, 2023, the Planning Commission, during a public hearing, reviewed the staff report of the Planning Division, received public comment and voted 7 ayes and 0 nay to recommend to the Board of Supervisors approval of the application for the zoning map amendment.

SECTION II:

The zoning map of Carson City is hereby amended to change the zoning designation from Limited Industrial (“LI”) and Single-Family 1 Acre (“SF1A”) to Single-Family 6,000 (“SF6”) for Assessor’s Parcel Number (“APN”) 010-061-87; from Single-Family 1 Acre (“SF1A”) to Single-Family 6,000 (“SF6”) for the southern, approximately 4.5 acres of APN 010-061-84 addressed at 1601 Fairview Drive; and from Limited Industrial (“LI”) to Single-Family 6,000 (“SF6”) for the northern, approximately 9.7 acres of APN 010-061-76 addressed at 1700

Colorado Street, as depicted in Attachment A, based on the findings that the zoning map amendment:

1. Is in substantial compliance with the goals, policies and action programs of the Carson City master plan.
2. Will provide for land uses that are compatible with existing adjacent land uses.
3. Will not have a detrimental impact on other properties within the vicinity.
4. Will not negatively impact existing or planned public services or facilities.
5. Will not adversely impact the health, safety or welfare of the public.
6. Satisfies all other required findings of fact as set forth in CCMC 18.02.075(5).

PROPOSED this \_\_\_\_ day of \_\_\_\_\_ 2023.

PROPOSED BY Supervisor \_\_\_\_\_

PASSED on the \_\_\_\_ day of \_\_\_\_\_ 2023.

VOTE: AYES: \_\_\_\_\_

\_\_\_\_\_

\_\_\_\_\_

\_\_\_\_\_

\_\_\_\_\_

NAYS: \_\_\_\_\_

\_\_\_\_\_

ABSENT: \_\_\_\_\_

\_\_\_\_\_

LORI BAGWELL, Mayor

ATTEST:

\_\_\_\_\_  
WILLIAM SCOTT HOEN, Clerk-Recorder

This ordinance shall be in force and effect from and after the \_\_\_\_ of \_\_\_\_\_, 2023.

# Attachment A



## STAFF REPORT FOR PLANNING COMMISSION MEETING OF JANUARY 25, 2023

**FILE: MPA-2023-0007 & ZA-2023-0008**

**AGENDA ITEM: 6.E & 6.F**

**STAFF CONTACT:** Heather Ferris, Planning Manager

### **AGENDA TITLE:**

**MPA-2023-0007** For Possible Action: Discussion and possible action regarding a request from Carson City (“Applicant”) for the adoption of a resolution approving a master plan amendment and recommending approval of the amendment to the Board of Supervisors (“Board”) to change the master plan designation from Mixed-Use Commercial (“MUC”) and Medium Density Residential (“MDR”) to MUC for three parcels located south of Fairview Drive, north of Colorado Street, and east of S. Saliman Road, Assessor’s Parcel Numbers (“APNs”) 010-061-76, 010-061-84, and 010-061-87. (Heather Ferris, hferris@carson.org).

Staff Summary: Through the annual review of the Master Plan and Zoning Map, the Board and staff have identified the subject parcels as appropriate for consideration of a mapping correction. These were before the Planning Commission for consideration as three separate Master Plan Amendments (MPA-2022-0502; MPA-2022-0499; and MPA-2022-0496) at their December 20, 2022 meeting and continued the items to the January 25, 2023 meeting. The recommendations have been consolidated and modified based on the discussions at December 20, 2022 meeting. The requested master plan amendment is being made concurrently with the request for a zoning map amendment (ZA 2023-0008).

**ZA-2023-0008** For Possible Action: Discussion and possible action regarding a recommendation to the Board of Supervisors (“Board”) concerning a request from Carson City (“Applicant”) for a proposed ordinance amending the zoning map to change the zoning from Limited Industrial (“LI”), Single-Family 1-Acre (“SF1A”) and Single-Family 6,000 (“SF6”) to General Commercial (“GC”) for three parcels located south of Fairview Drive, north of Colorado Street, and east of S. Saliman Road, Assessor’s Parcel Numbers (“APNs”) 010-061-76, 010-061-84, and 010-061-87. (Heather Ferris, hferris@carson.org).

Staff Summary: Through the annual review of the Master Plan and Zoning Map, the Board and staff have identified the subject parcels as appropriate for consideration of a mapping correction. These were before the Planning Commission for consideration as three separate Zoning Map Amendments (ZA-2022-0500; ZA-2022-0495; and ZA-2022-0494) at their December 20, 2022 meeting and continued the items to the January 25, 2023 meeting. The recommendations have been consolidated and modified based on the discussions at December 20, 2022 meeting. The requested zoning map amendment is being made concurrently with the request for a Master Plan Amendment (MPA-2023-0007).

**MASTER PLAN AMENDMENT RECOMMENDED MOTION:** “I move to adopt resolution number 2023-PC-R-1.”

**ZONING MAP AMENDMENT RECOMMENDED MOTION:** “I move to recommend to the Board of Supervisors approval of the zoning map amendment ZA-2023-0008 as presented.”



**VICINITY MAP:**

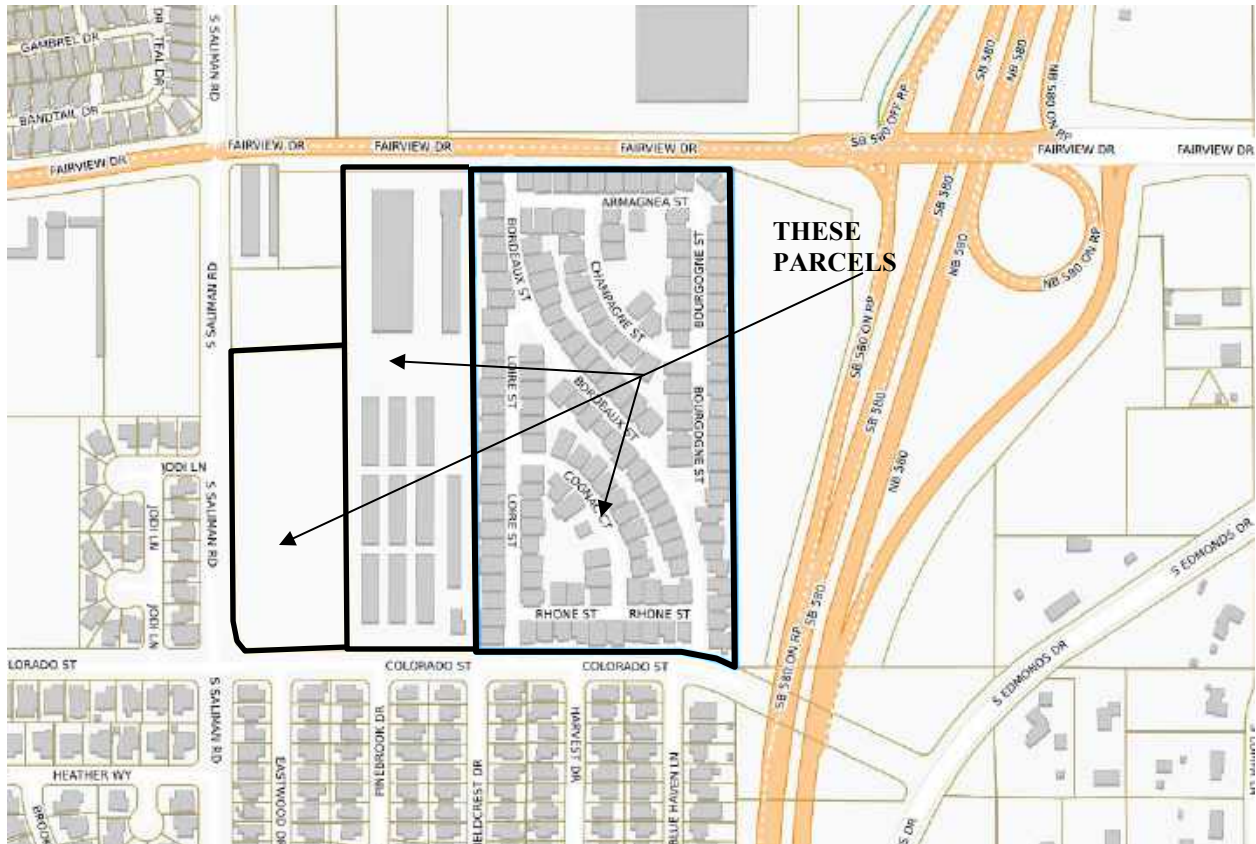

**EXISTING MASTER PLAN**

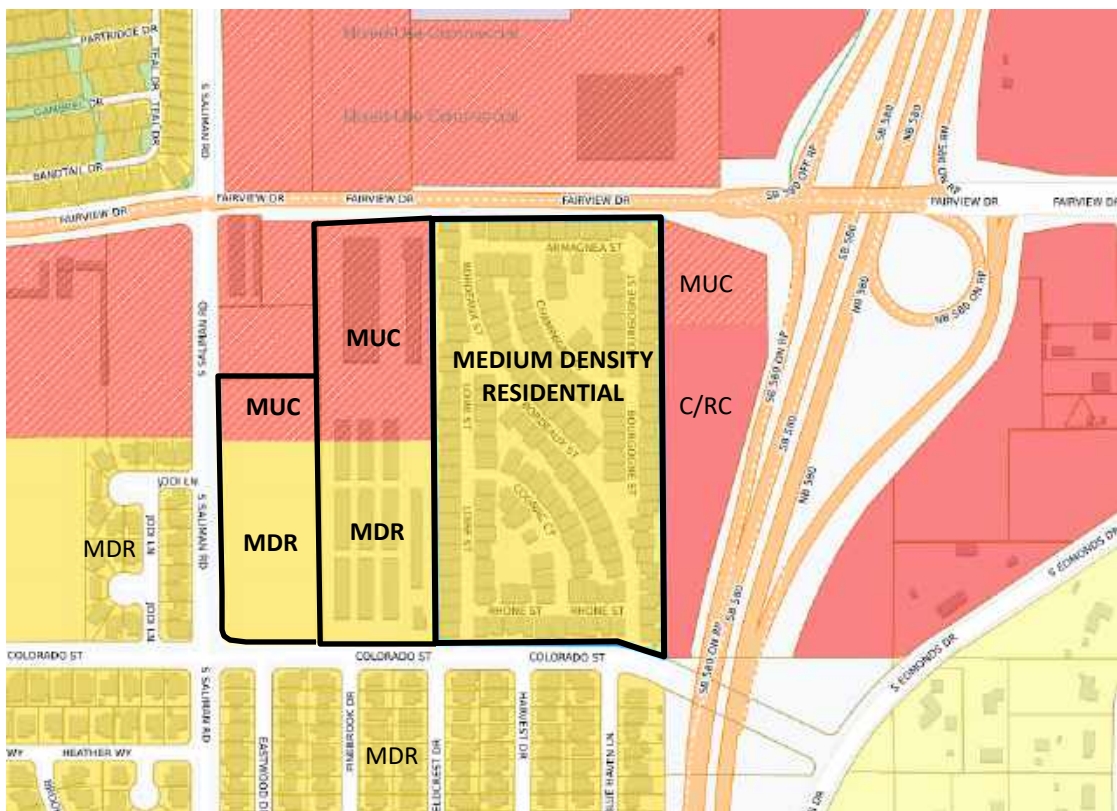



**PROPOSED MASTER PLAN**

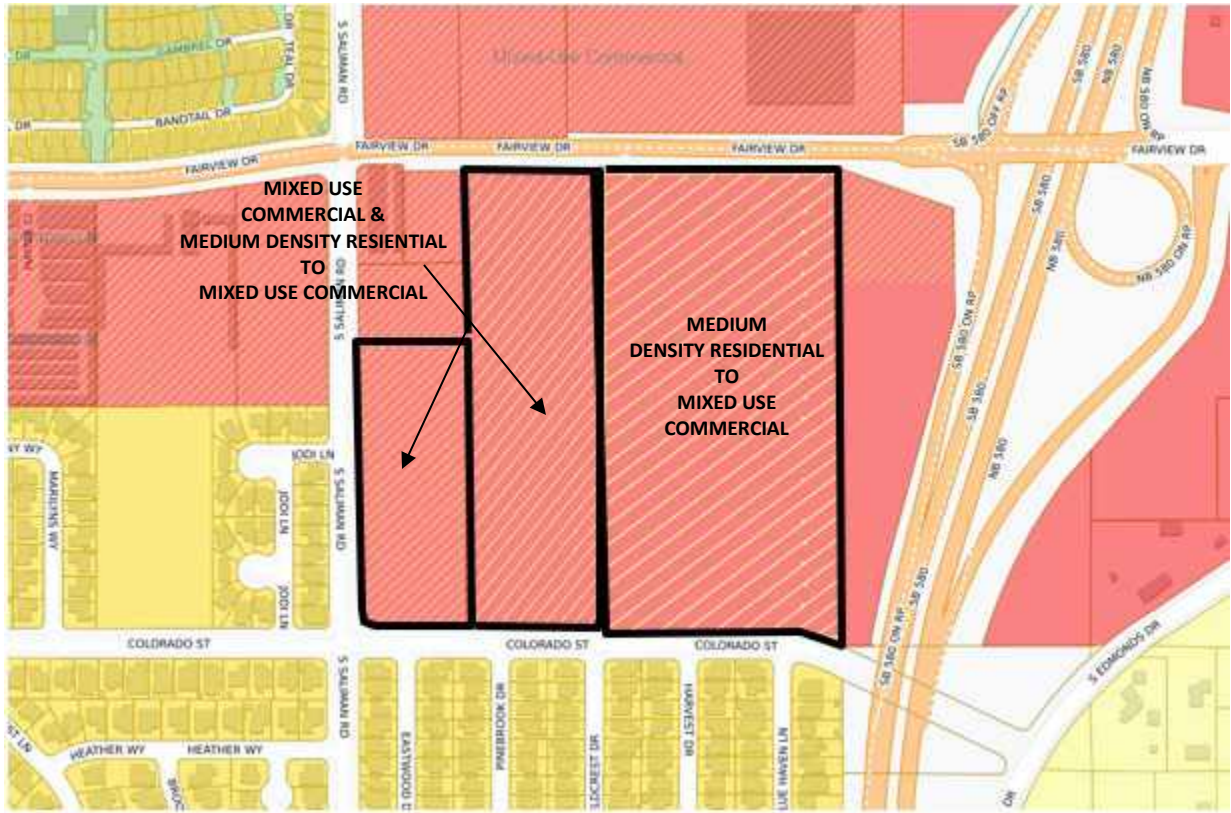

**EXISTING ZONING**

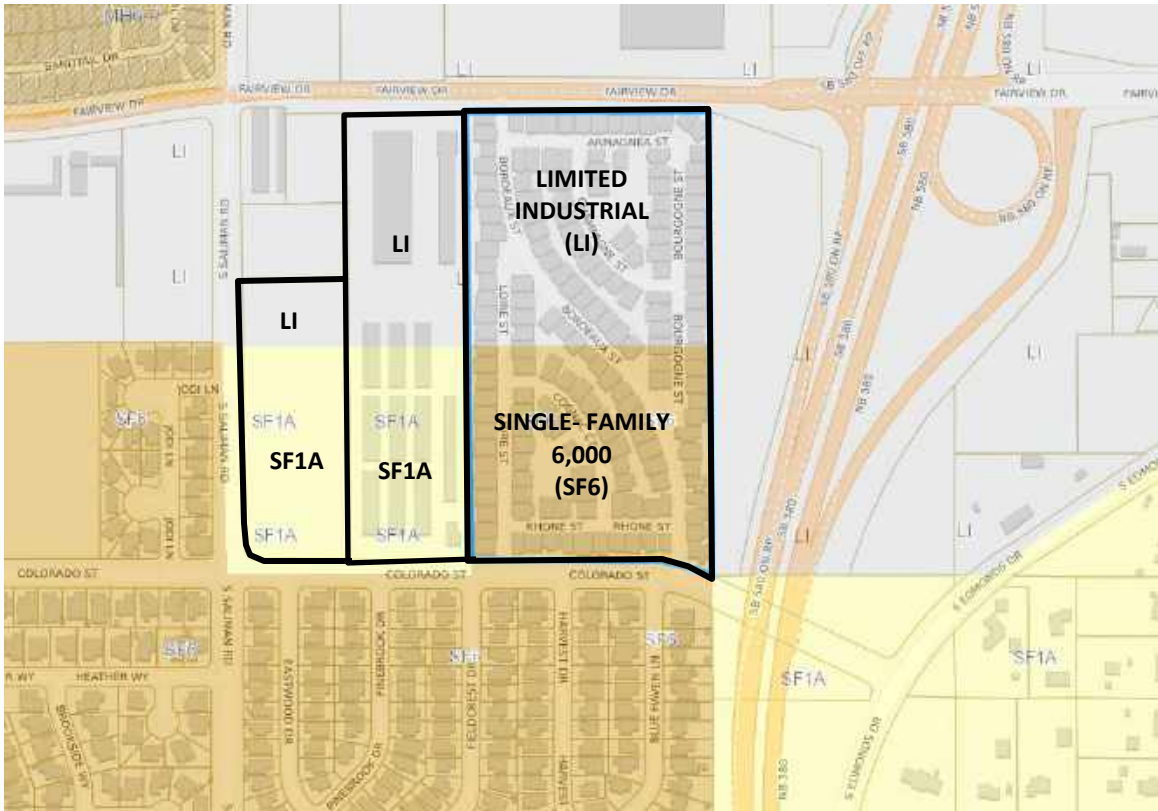

## **PROPOSED ZONING**

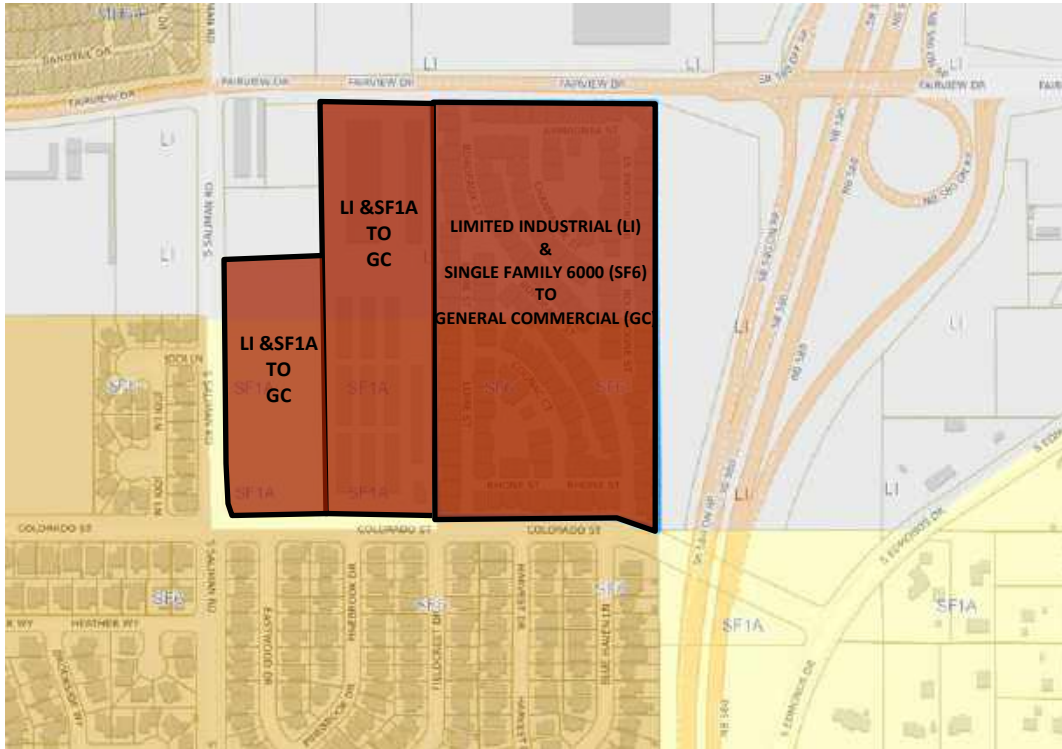

**LEGAL REQUIREMENTS:** Carson City Municipal Code (“CCMC”) 18.02.050 (Review); CCMC 18.02.070 (Master Plan); CCMC 18.02.075 (Zoning Map Amendments and Zoning Code Amendments)

**EXISTING MASTER PLAN DESIGNATION:** Medium Density Residential (“MDR”) & Mixed Use Commercial (“MUC”)

**PROPOSED MASTER PLAN DESIGNATION:** Mixed-Use Commercial (“MUC”)

**EXISTING ZONING:** Limited Industrial (“LI”) & Single-Family 6,000 (“SF6”) & Single-Family 1 acre (“SF1A”)

**PROPOSED ZONING:** General Commercial (“GC”)

### **SURROUNDING ZONING AND LAND USE INFORMATION:**

**NORTH:** Limited Industrial / distribution warehouse & vacant

**SOUTH:** Single-Family 6,000 / single family residences

**EAST:** Limited Industrial / NDOT right-of-way parcel with trail

**WEST:** Limited Industrial & Single-Family 6,000 / vacant & single-family residences

### **BACKGROUND:**

At its meeting of December 15, 2021, the Planning Commission was provided with an update on the Master Plan implementation activities and reviewed and made a recommendation to the Board of Supervisors on the Master Plan Action Plan and other Master Plan related matters. At its meeting of January 20, 2022, the Board of Supervisors accepted the 2021 Master Plan report from the Planning Commission and identified the subject parcel as appropriate for consideration of a mapping correction.

This was before the Planning Commission for consideration as three separate Master Plan Amendments (MPA-2022-0502; MPA-2022-0499; and MPA-2022-0496) and Zoning Map Amendments (ZA-2022-0500; ZA-2022-0495; and ZA-2022-0494) at their December 20, 2022 meeting and continued the items to the January 25, 2023 meeting. The recommendations have been consolidated and modified based on the discussions at December 20, 2022 meeting.

#### **DISCUSSION:**

The subject parcels are in an area with a mix of uses including residential, warehousing, personal storage, office space, and retail.

APN 010-061-87 is located at the northeast corner of S. Saliman Road and Colorado Street. The parcel is currently vacant and has a split master plan designation of MUC and MDR and split zoning of LI and SF1A. The zoning and master plan are not consistent with one another.

APN 010-061-84 is located at 1601 Fairview Drive. The parcel is currently developed with office, warehouse, and storage uses. There is a split master plan designation of MUC and MDR and a split zoning of LI and SF1A. The zoning and master plan are not consistent with one another.

APN 010-061-76 is located at 1700 Colorado and is developed with a manufactured home park. The master plan designation is MDR and there is a split zoning of LI and SF6. The existing zoning and master plan are not consistent with one another nor are they consistent with the existing use of a manufactured home park. The manufactured home park was approved in 1985. At that time the property was zoned LI and SF6 as well and the zoning code allowed for a mobile home park in these zoning districts subject to a special use permit. Since that time, the zoning code has changed making this a non-conforming use.

The proposed amendments will result in a master plan and zoning that are consistent with one another and consistent with the existing on-site use as the proposed General Commercial zoning allows for offices, personal storage, and manufactured home parks (subject to a special use permit).

The Planning Commission adopts the master plan amendment and makes a recommendation to the Board of Supervisors by resolution and makes a recommendation to the Board of Supervisors on the zoning map amendment.

**PUBLIC COMMENTS:** On January 12, 2023, public hearing notices were mailed to 185 property owners and 167 mobile home park residents within 600 feet of the subject property in accordance with the provisions of NRS and CCMC 18.02.045. At the time of the writing of this report staff has not received any public comment. Any comments that are received after this report is completed will be provided to the Planning Commission either prior to or at the January 25, 2023 meeting depending on their submittal date to the Planning Division.

**FINDINGS:** Staff recommends the following findings for approval of the Master Plan Amendment and Zoning Map Amendment pursuant to CCMC 18.02.070 Master Plan and 18.02.075, Zoning Map Amendments and Zoning Code Amendments.

Master Plan Amendment Findings:**1. The proposed amendment is in substantial compliance with the goals, policies and action programs of the Master Plan.**

The subject parcels consist of a manufacture home park, a personal storage/office use, and a vacant parcel. The master plan designations of the two western-most parcels are split MUC and MDR and the eastern most parcel is designated MDR. These designations are not consistent with the existing zoning or the on-site uses. The proposed amendment will result in all three parcels having a designation of MUC which will provide consistency with parcels to the north, west, and east. The MUC designation is intended to encourage a more compact, mixed-use pattern of development along the City's major gateway corridors. Commercial retail and offices are anticipated to be the primary used within the MUC designation; however, residential uses are also anticipated. While single use developments are not encouraged in the MUC zoning district, they may be appropriate when considering the surrounding area. The area surrounding the subject parcels has a diversity of uses including residential, commercial, light industrial, and recreational uses. The proposed amendment is in substantial compliance with the goals, policies, and action programs of the Master Plan.

**2. The proposed amendment will provide for land uses compatible with existing adjacent land uses and will not have detrimental impacts to other properties in the vicinity.**

The master plan designations of the two western-most parcels are split MUC and MDR and the eastern most parcel is designated MDR. These designations are not consistent with the existing zoning or the on-site uses. The proposed amendment will result in the parcels having a designation of MUC which will provide consistency with parcels to the north, west, and east and will result in a master plan and consistent with the existing on-site uses. The two eastern-most parcels are developed with personal storage and office uses, and a manufactured home park. The western-most parcel is vacant. There is no proposed change in use for any of these parcels.

**3. The proposed amendment is in response to changed conditions that have occurred since the plan was adopted and the requested amendment represents a more desirable use of land.**

At its meeting of January 20, 2022, the Board of Supervisors accepted the 2021 Master Plan report from the Planning Commission and identified the subject parcels as appropriate for consideration of a mapping correction. The proposed amendment will result in the parcels having a designation of MUC which will provide consistency with parcels to the north, west, and east and will result in a master plan consistent with the existing on-site uses.

**4. The requested amendment will promote the desired pattern of orderly physical growth and guides development based on the projected population growth with the least amount of natural resource impairment and the efficient expenditure of funds for public services.**

The proposed amendment will provide the desired patter of orderly growth. The proposed amendment will result in the parcels having a designation of MUC which will provide consistency with parcels to the north, west, and east and will result in a master plan consistent with the existing on-site uses. The two eastern most parcels are developed with personal storage and offices, and a manufactured home park and there is no proposed change in use; therefore, the amendment will not result in impacts to public services.

Zoning Map Amendment Findings:

**1. That the proposed amendment is in substantial compliance with and supports the goals and policies of the master plan.**

The proposed amendment is consistent with the Master Plan. Chapter 3 of the Master Plan identifies the land use designations and identifies what zoning districts corresponds to the land use designation.

The subject parcels include a vacant parcel, a parcel that is developed with office space and personal storage, and a manufactured home park. The proposed MUC designation is intended to encourage a more compact, mixed-use pattern of development along the City's major gateway corridors. Commercial retail and offices are anticipated to be the primary use within the MUC designation; however, residential uses are also anticipated. While single use developments are not encouraged in the MUC zoning district, they may be appropriate when considering the surrounding area. The area surrounding the subject parcels has a diversity of uses including residential, commercial, light industrial, and recreational uses. If the master plan is amended to designate all three parcels as MUC, the proposed General Commercial zoning district would be a corresponding zoning district that will implement the Master Plan.

**2. That the proposed amendment will provide for land uses compatible with existing adjacent land uses and will not have detrimental impacts to other properties in the vicinity.**

The proposed zoning map amendment will create consistency with the proposed master plan designation of MUC. Additionally, the proposed amendment will result in the parcel having a zoning of GC which will provide transition between the SF6 parcels to the south and the Limited Industrial zoned parcels to the north. The proposed amendment will also result in zoning that is consistent with the master plan and consistent with the existing on-site use.

**3. That the proposed amendment will not negatively impact existing or planned public services or facilities and will not adversely impact the public health, safety and welfare.**

The proposed zoning map amendment will not negatively impact existing or planned public services or facilities and will not adversely impact the public health, safety and welfare. Two of the three parcels are developed and there is no proposed change in use; therefore, the amendment will not result in impacts to public services. The western most parcel is vacant and there is no proposed development at this time. Any future development of this parcel will be required to provide appropriate project impact reports to demonstrate that existing facilities can meet the demand within the standards set by municipal code or mitigate impacts as part of the project.

Attachments:

Resolution

Draft zoning map amendment ordinance

**RESOLUTION 2023-PC-R-1**

A RESOLUTION ADOPTING AND RECOMMENDING TO THE BOARD OF SUPERVISORS ADOPTION OF MPA-2023-007, A MASTER PLAN AMENDMENT TO CHANGE THE LAND USE MAP FROM MIXED-USE COMMERCIAL (“MUC”) AND MEDIUM DENSITY RESIDENTIAL (“MDR”) TO MUC FOR THREE PARCELS LOCATED SOUTH OF FAIRVIEW DRIVE, NORTH OF COLORADO STREET AND EAST OF S. SALIMAN ROAD, ASSESSOR’S PARCEL NUMBERS (“APNs”) 010-061-76; 010-061-84; AND 010-061-87.

WHEREAS, section 278.210 of the Nevada Revised Statutes (“NRS”) requires that any adoption of a master plan amendment shall be by resolution of the Carson City Planning Commission; and

WHEREAS, the Planning Commission has given proper notice of the proposed amendment in accordance with the provisions of NRS and Carson City Municipal Code (“CCMC”) 18.02.070, and is in conformance with City and State legal requirements; and

WHEREAS, on January 25, 2023, the Planning Commission obtained public testimony and duly considered recommendations and findings for the proposed master plan amendment and recommended approval of master plan amendment MPA-2023-0007 by an affirmative vote of a two-thirds majority of the Commission, at least five members of the seven-member Commission, pursuant to NRS 278.210, based on four findings of fact: and

WHEREAS, the proposed Master Plan land use designations would be consistent with the existing and intended uses of the property;

NOW, THEREFORE, the Carson City Planning Commission hereby adopts, and recommends to the Carson City Board of Supervisors adoption of, the master plan amendment to change the land use map designation from MUC and MDR to MUC for three parcels located south of Fairview Drive, north of Colorado Street and east of S. Saliman Road, APNs 010-061-76; 010-061-84; and 010-061-87.

ADOPTED this 25th day of January 2023

VOTE: AYES:

NAYS:

ABSENT:

\_\_\_\_\_  
, Chairman

ATTEST:

\_\_\_\_\_  
Hope Sullivan, AICP, Community Development Director



SUMMARY – Amends the Carson City zoning map.

BILL NO. \_\_\_\_\_  
ORDINANCE NO. 2023-\_\_

AN ORDINANCE RELATING TO ZONING; ESTABLISHING VARIOUS PROVISIONS TO CHANGE THE ZONING FROM LIMITED INDUSTRIAL (“LI”), SINGLE-FAMILY 1 ACRE (“SF1A”) AND SINGLE-FAMILY 6,000 (“SF6”) TO GENERAL COMMERCIAL (“GC”) FOR THREE PARCELS LOCATED SOUTH OF FAIRVIEW DRIVE, NORTH OF COLORADO STREET, AND EAST OF S. SALIMAN ROAD, ASSESSOR’S PARCEL NUMBERS (“APNs”) 010-061-76; 010-061-84; AND 010-061-87.

The Board of Supervisors of Carson City do ordain:

SECTION I:

An application for a zoning map amendment affecting Assessor’s Parcel Numbers (“APNs”) 010-061-76; 010-061-84; AND 010-061-87, located south of Fairview Drive, north of Colorado Street, and east of S. Saliman Road, Carson City, Nevada, was duly submitted to the Planning Division of the Carson City Community Development Department in accordance with section 18.02.075 of the Carson City Municipal Code (“CCMC”) to revise the existing zoning designations of APNs 010-061-76; 010-061-84; and 010-061-87 from Limited Industrial (“LI”), Single-Family 1 acres (“SF1A”), and Single-Family 6,000 (“SF6”) to General Commercial (“GC”). After proper noticing in accordance with Chapter 278 of the Nevada Revised Statutes and CCMC Title 18, on January 25, 2023, the Planning Commission, during a public hearing, reviewed the staff report of the Planning Division, received public comment and voted \_\_ ayes and \_\_ nay to recommend to the Board of Supervisors approval of the application for the zoning map amendment.

SECTION II:

The zoning map of Carson City is hereby amended to change the zoning designation from Limited Industrial (“LI”), Single-Family 1 acre (“SF1A”), and Single-Family 6,000 (“SF6”) to General Commercial (“GC”) for APNs 010-061-76; 010-061-84; and 010-061-87, as depicted in Attachment A, based on the findings that the zoning map amendment:

1. Is in substantial compliance with the goals, policies and action programs of the Carson City master plan.
2. Will provide for land uses that are compatible with existing adjacent land uses.
3. Will not have a detrimental impact on other properties within the vicinity.
4. Will not negatively impact existing or planned public services or facilities.
5. Will not adversely impact the health, safety or welfare of the public.
6. Satisfies all other required findings of fact as set forth in CCMC 18.02.075(5).

PROPOSED this \_\_\_\_\_ day of \_\_\_\_\_ 2023.

PROPOSED BY Supervisor \_\_\_\_\_

PASSED on the \_\_\_\_\_ day of \_\_\_\_\_ 2023.

VOTE:

AYES: \_\_\_\_\_  
\_\_\_\_\_  
\_\_\_\_\_  
\_\_\_\_\_  
\_\_\_\_\_

NAYS: \_\_\_\_\_  
\_\_\_\_\_

ABSENT: \_\_\_\_\_  
\_\_\_\_\_

\_\_\_\_\_  
LORI BAGWELL, Mayor

ATTEST:

\_\_\_\_\_  
WILLIAM SCOTT HOEN, Clerk-Recorder

This ordinance shall be in force and effect from and after the \_\_\_\_ of \_\_\_\_\_,  
2023.



# Attachment A

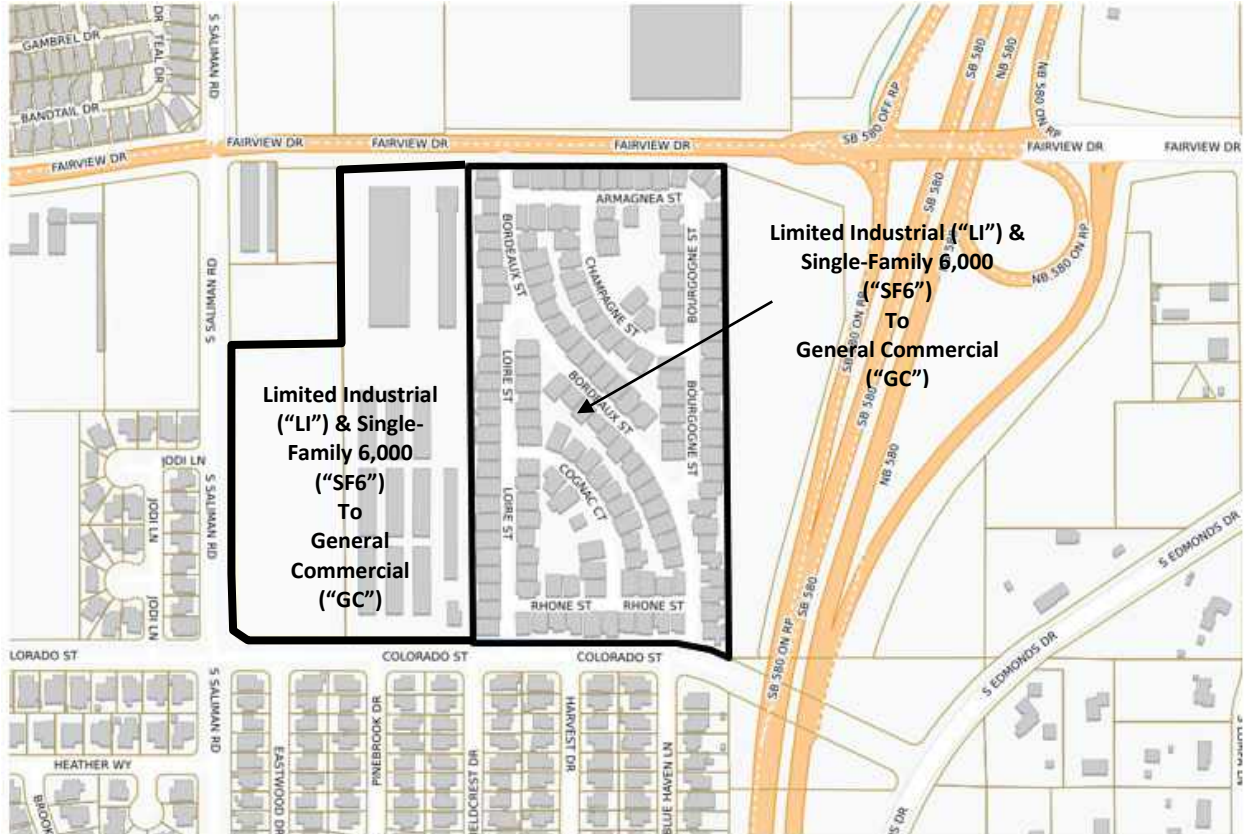

(7:55:38) – Commissioner Borders moved to approve the Special Use Permit LU-2022-0541 based on the ability to make the required findings, and subject to the Conditions of Approval contained in the Staff Report. The motion was seconded by Commissioner Killgore.

<b>RESULT:</b>	<b>APPROVED (7-0-0)</b>
<b>MOVER:</b>	Borders
<b>SECONDER:</b>	Killgore
<b>AYES:</b>	Preston, Borders, DeChristopher, Krahn, Killgore, Loyd, Perry
<b>NAYS:</b>	None
<b>ABSTENTIONS:</b>	None
<b>ABSENT:</b>	None

**ITEMS 6.E AND 6.F**

(7:56:26) – Vice Chair Preston introduced items 6.E and 6.F. Both items would be discussed concurrently; however, they would be voted on separately. Ms. Ferris presented the Staff Report, incorporated into the record, for both items, noted that all written public comments received regarding the item were posted with the agenda materials, and responded to clarifying questions. Ms. Sullivan explained that the item was noticed to change the master plan designation from Mixed-Use Commercial and Medium Density Residential to Mixed-Use Commercial “to give this Commission flexibility” in case they wanted to have a Residential designation. Commissioner Borders noted that most of the lots were residential with the exception of the storage business, which he believed would be non-conforming should the designation change to Residential. Ms. Ferris reviewed the existing zoning for the Commissioners and noted several inconsistencies. She believed that the General Commercial zoning would allow the manufactured home park and create conformity.

(8:08:25) – Commissioner Perry was informed that currently the storage unit and the mobile home park were non-conforming uses, adding that Medium Family Residential zoning would not allow Single-Family Residential zoning. Ms. Ferris confirmed that a Conditional Special Use Permit existed for the mobile home park. Vice Chair Preston entertained public comments.

(8:17:33) – Frank Abella introduced himself as a representative of “a lot of the residents behind me.” Mr. Abella noted the traffic in the area in terms of noise, emissions, and speeders at the intersection of Colorado Street and Saliman Road. He also expressed concern about what could be built “in that vacant lot that’s adjacent to Saliman [Road].” Kimberly Adams introduced herself as a resident who lives across the vacant lot and was concerned about a commercial business taking it over and creating a traffic hazard to students using the bus stop across from her home. She also clarified that the mobile home park is occupied by seniors only who walk their pets. Ms. Adams was also concerned about the potential decline of the property values and urged the Board to keep the Single-Family zoning. Jarrod Adams introduced himself as a Carson City resident and a retired Carson City Sheriff’s Office (CCSO) deputy and believed that the zoning change of the parcel at Colorado Street and Saliman Road would be detrimental to the residents.

(8:24:55) – Jason Tingle introduced himself as an area resident and was concerned about his children’s safety. He believed that there were many vacant commercial lots in the City and recommended keeping the zoning residential for the safety of the schoolchildren. Ms. Partee noted the heavy traffic on both Fairview Drive and Colorado Street and suggested grandfathering the mobile home park and the storage unit and allowing them to remain in the Residential zone. Ms. Schiller was concerned about the traffic noise and the traffic near Colorado Street and Saliman Road. She was opposed to Commercial zoning and was concerned about bicycle and pedestrian safety. Ms. Trushenski also spoke in opposition to the Commercial zoning near residential areas and agreed with Mr. Tingle’s comments. Joseph Zich introduced himself as an area resident and believed that the Commercial zoning would be detrimental to the neighborhood. He was also concerned for the safety of the residents. Rhonda Price introduced herself as an area resident and highlighted the current traffic in the area and believed the traffic would be increased with the zoning change which would jeopardize the safety of the students using the bus stop.

(8:36:11) – John MacSween introduced himself as a partner in the MacSween-Hoseit Partnership, owners of Assessor’s Parcel Number (APN) 010-061-84. He also read into the record his written public comments, incorporated into the record as late material, in which he opposed the zoning change, and urged the Commission to vote against the proposed zoning change. Jessi Tingle introduced herself as an area resident with three children who walk to the area bus stop or walk to school. She expressed concern about the traffic and wished to keep the zoning as is. Ms. Strasburg believed that the Board of Supervisors had supported Conformity to the existing neighborhood and that was her preference as well. There were no additional comments. Vice Chair Preston entertained Commissioner discussion.

(8:42:55) – Commissioner Loyd was informed that the City models had not indicated any plans for the intersection of Saliman Road and Colorado Street and that the recommendations would be presented at the time a project is proposed. Commissioner Killgore thanked members of the public for their comments. Commissioner DeChristopher explained that she had driven through the area and had wondered whether the zoning change would have detrimental impacts on other properties in the vicinity. Commissioner Perry informed Mr. MacSween that the storage facility he owned would become “non-compliant should there be a 12-month lapse in the currently compliant usage” which Mr. MacSween had outlined in his letter. However, Ms. Sullivan clarified that due to the split-zoning of the property, the storage unit would not be prohibited but would be considered a conditional use due to the split-zoned parcel. She also informed Commissioner Perry that “when you have a split-zoned parcel, you can choose to establish a use that’s allowed in one of those uses in one of those zoning districts on the entire parcel with a Special Use Permit.” Discussion ensued regarding the advantages and disadvantages of the zoning changes.

(8:57:49) – Based on the discussion, Ms. Ferris recommended the following:

- On “the westernmost corner parcel” which is currently zoned as Mixed Use and Medium Density Residential, she recommended leaving the Master Plan as is and zoning it as Single Family 6,000 (SF6) and keeping it as conforming use.

- On the “middle parcel,” Ms. Ferris recommended leaving “the Master Plan as is and going with an SF6 zoning, over the Medium Density Residential portion. It remains non-conforming, but it allows for any future development in that area to essentially conform with the neighborhood.”
- As for the mobile home park, “we can leave it as is with the Master Plan and do SF6 zoning over the top of it. It’s still non-conforming but it’s a Residential Use [and] at least the zoning would conform with the Master Plan.

(9:00:18) – Another alternative, according to Ms. Ferris would be to “consider doing the recommended General Commercial zoning with Mixed Use with Commercial Master Plan.” Ms. Sullivan noted that “the Master Plan Makes Sense...we’re dealing with zoning districts that aren’t consistent with Master Plan. It’s not simply academic.”

(9:04:55) – Ms. Adams received confirmation that the Light Industrial zoning would no longer be considered in Ms. Ferris’ recommendation.

**6.E MPA-2023-0007 FOR POSSIBLE ACTION: DISCUSSION AND POSSIBLE ACTION REGARDING A REQUEST FROM CARSON CITY (“APPLICANT”) FOR THE ADOPTION OF A RESOLUTION APPROVING A MASTER PLAN AMENDMENT AND RECOMMENDING APPROVAL OF THE AMENDMENT TO THE BOARD OF SUPERVISORS (“BOARD”) TO CHANGE THE MASTER PLAN DESIGNATION FROM MIXED-USE COMMERCIAL (“MUC”) AND MEDIUM DENSITY RESIDENTIAL (“MDR”) TO MUC FOR THREE PARCELS LOCATED SOUTH OF FAIRVIEW DRIVE, NORTH OF COLORADO STREET, AND EAST OF S. SALIMAN ROAD, ASSESSOR’S PARCEL NUMBERS (“APNS”) 010-061-76, 010-061-84, AND 010-061-87.**

(9:05:20) – Based on the discussion above, no action would be required on this item according to Ms. Sullivan as no changes would be proposed.

**6.F ZA-2023-0008 FOR POSSIBLE ACTION: DISCUSSION AND POSSIBLE ACTION REGARDING A RECOMMENDATION TO THE BOARD OF SUPERVISORS (“BOARD”) CONCERNING A REQUEST FROM CARSON CITY (“APPLICANT”) FOR A PROPOSED ORDINANCE AMENDING THE ZONING MAP TO CHANGE THE ZONING FROM LIMITED INDUSTRIAL (“LI”), SINGLE-FAMILY 1-ACRE (“SF1A”) AND SINGLE-FAMILY 6,000 (“SF6”) TO GENERAL COMMERCIAL (“GC”) FOR THREE PARCELS LOCATED SOUTH OF FAIRVIEW DRIVE, NORTH OF COLORADO STREET, AND EAST OF S. SALIMAN ROAD, ASSESSOR’S PARCEL NUMBERS (“APNS”) 010-061-76, 010-061-84, AND 010-061-87.**

(9:05:40) – Ms. Ferris summarized the zoning discussion above and reiterated the following:

- “The zoning for the parcel to the west, at the corner of Saliman [Road] and Colorado [Street], would be changed from Limited Industrial and Single-Family 1 Acre to Single Family 6,000.”

- “The zoning for the parcel in the middle, between Fairview [Drive] and Colorado [Street], we’d be looking at leaving the Limited Industrial zoning as is and modifying the zoning from Single Family 1 Acre to Single Family 6,000 for the southern portion.”
- “[For] the parcel that is the mobile home park, the Single Family 6,000 zoning would be applied to the entire parcel. So, Limited Industrial would be amended to Single Family 6,000.”

**(9:07:10) – Commissioner Borders moved to recommend to the Board of Supervisors approval of the zoning map amendment ZA-2023-0008 as discussed and summarized by the Planning Manager. The motion was seconded by Vice Chair Preston.**

<b>RESULT:</b>	<b>APPROVED (7-0-0)</b>
<b>MOVER:</b>	Borders
<b>SECONDER:</b>	Preston
<b>AYES:</b>	Preston, Borders, DeChristopher, Krahn, Killgore, Loyd, Perry
<b>NAYS:</b>	None
<b>ABSTENTIONS:</b>	None
<b>ABSENT:</b>	None

(9:07:44) – Vice Chair Preston recessed the meeting.

(9:17:31) – Vice Chair Preston reconvened the meeting. A quorum was still present.

**6.G ZA-2022-0519 FOR POSSIBLE ACTION: DISCUSSION AND POSSIBLE ACTION REGARDING A RECOMMENDATION TO THE BOARD OF SUPERVISORS (“BOARD”) CONCERNING AN APPLICATION FROM WILL ADLER ON BEHALF OF GREEN THUMB INDUSTRIES INC. (“APPLICANT”) FOR AN ORDINANCE AMENDING LOCATION LIMITATIONS FOR MEDICAL MARIJUANA DISPENSARIES AND MARIJUANA RETAIL STORES.**

(9:17:35) – Vice Chair Preston introduced the item. Ms. Sullivan gave background and presented the Staff Report with the accompanying documentation and responded to clarifying questions.

(9:26:37) – Applicant representative Will Adler, Principal at Silver State Government Relations, reviewed a PowerPoint presentation, incorporated into the record, introducing Green Thumb Industries, Inc. He also discussed the current zoning for cannabis sales and proposed a zoning change to open a second retail location in the North Carson area to accommodate their second license. Mr. Adler cited the lack of available property in the current zoning areas, which had led his clients to their zoning expansion request. Mr. Adler also responded to Commissioner questions. Vice Chair Preston entertained public comments.

(9:43:01) – Ms. Strasburg reiterated the contents of her written public comments, incorporated into the record as late material, in which she recommended that the Commission deny the applicant’s request for a



## STAFF REPORT

**Report To:** Board of Supervisors                      **Meeting Date:** March 2, 2023

**Staff Contact:** Hope Sullivan, AICP, Planning Manager

**Agenda Title:** For Possible Action: Discussion and possible action regarding a request from Will Adler on behalf of Green Thumb Industries Inc. ("Applicant") to introduce, on first reading, a proposed ordinance providing location requirements for medical marijuana dispensaries and marijuana retail stores in the retail commercial ("RC") use district. (Hope Sullivan, hsullivan@carson.org)

Staff Summary: The Applicant is proposing to amend Carson City Municipal Code ("CCMC") 18.03.130 to allow marijuana retail stores and medical marijuana dispensaries in the RC use district within Township 15N, Range 20E, Sections 5, 6 and 8 which is generally the area along North Carson Street, north of Winnie Lane, west of Hot Springs Road and south of Arrowhead Drive and Medical Parkway. The Planning Commission has recommended approval of the proposed amendment to the zoning code, with a prohibition against medical marijuana dispensaries or marijuana retail stores north of Arrowhead Drive and Medical Parkway. Pursuant to Nevada Revised Statutes ("NRS") Chapter 237, a business impact statement is not required to be prepared with this ordinance.

**Agenda Action:** Ordinance - First Reading                      **Time Requested:** 20 Minutes

---

### **Proposed Motion**

I move to introduce, on first reading, Bill No. \_\_\_\_.

### **Board's Strategic Goal**

Economic Development

### **Previous Action**

January 25, 2023 (Item 6G): The Planning Commission conducted a public hearing and voted 4 – 3 to recommend approval of the ordinance with no medical marijuana dispensaries or marijuana retail stores permitted to the north of Arrowhead Drive and Medical Parkway. Those voting against the proposed ordinance cited land use compatibility concerns.

### **Background/Issues & Analysis**

See the attached memo and staff report to the Planning Commission for additional information.

Except as specifically exempted, NRS 237.080 requires a business impact statement to be prepared whenever an ordinance by the adoption of which the governing body of a local government exercises legislative powers. Under these exemptions, a business impact statement is not required to be prepared with this ordinance because the ordinance is proposed pursuant to a provision of NRS Chapter 278.

### **Applicable Statute, Code, Policy, Rule or Regulation**

NRS Chapters 237 and 244; Article 2 of the Carson City Charter; CCMC 18.04.130



**Financial Information**

Is there a fiscal impact? No

If yes, account name/number:

Is it currently budgeted? No

Explanation of Fiscal Impact:

**Alternatives**

Do not introduce the ordinance, modify the ordinance and/or provide alternative direction to staff.

**Attachments:**

[Ordinance 1st readng Marijuana locations ter clean.docx](#)

[6.G Staff Report, Attachments and Late Material.pdf](#)

**Board Action Taken:**

Motion: \_\_\_\_\_

1) \_\_\_\_\_

2) \_\_\_\_\_

Aye/Nay

\_\_\_\_\_

\_\_\_\_\_

\_\_\_\_\_

\_\_\_\_\_

\_\_\_\_\_

\_\_\_\_\_  
(Vote Recorded By)

Summary: An ordinance providing location requirements for medical marijuana dispensaries and marijuana retail stores in the retail commercial use district.

BILL NO. \_\_\_\_\_

ORDINANCE NO. 2023 - \_\_\_\_\_

AN ORDINANCE RELATING TO ZONING; PROVIDING PROVISIONS SPECIFYING THE PERMITTED LOCATIONS OF MARIJUANA RETAIL STORES AND MEDICAL MARIJUANA DISPENSARIES IN RETAIL COMMERCIAL USE DISTRICTS; AND PROVIDING OTHER MATTERS PROPERLY RELATED THERETO.

The Board of Supervisors of Carson City do ordain:

SECTION I:

That Title 18 (ZONING), Chapter 18.04 (USE DISTRICTS), Section 18.04.130 (Retail Commercial (RC)), is hereby amended (**bold, underlined** text is added, ~~stricken~~ text is deleted) as follows:

**18.04.130 - Retail commercial (RC). (NRS 278.250)**

The purpose of the RC District is to preserve a commercial district limited primarily to offices and retail sale of new merchandise and excluding all uses in the General Commercial and Industrial Districts, except for some service uses which are compatible with the zone. All uses within the RC District shall be conducted within a building, and aside from display windows, be screened from view. Outdoor display and storage of autos, recreational vehicles, or mobilehomes in conjunction with an existing business with sales of autos, recreation vehicles and mobilehomes is allowed in accordance with Division 2 of the Development Standards and provided the vehicles or mobilehomes do not encroach into City or State Right-of-Way without an approved encroachment permit and are screened from adjacent parcels. Temporary outdoor display and sale of merchandise for a period not to exceed 30 days within a calendar year may be authorized by the Director subject to Title 18.02.115.8 (Outdoor Sales and Activities).

1. The Primary Permitted Uses in the RC District are this list, those uses allowed in 18.04.120 Neighborhood Business, except those uses appearing in Section 18.04.130.3 Retail Commercial as Conditional uses which require a Special Use Permit, plus other uses of a similar nature:

Accounting and Bookkeeping

Alcoholic Beverage Sales (accessory to a restaurant)

Amusement Devices, Sales and Service

Apparel Shop

Appliances

Art Studio



Artist, Commercial  
Astrology Parlor/Fortune Telling/Clairvoyance and Palmistry  
Automobile Parts, Tires and Accessories  
Automobile Rental  
Automobile Retail New or Used  
Automobile Service (automobile gas, maintenance and repair service, no body repair)  
Bible and Church Supplies  
Blood Bank  
Blueprint and Photocopy Services  
Boarding and Rooming House  
Body Piercing  
Bowling Alley  
Brew Pub  
Cafeteria  
Candy and Confectionary, Retail  
Carpet and Floor Coverings  
Caterer  
Ceramics, Ceramic Products with Kiln  
Chemist, Analytical and Consulting  
Christmas Tree Sales  
Clock, Retail and Repair  
Club, Supper and Amusement  
Collectible Store  
Computer Sales and Repair  
Copy Center  
Costumes, Party and Wedding Supplies and Rental  
Credit Bureau  
Delivery Service  
Department Store  
Detective or Private Investigation Agency  
Draperies, Blinds and Window Coverings  
Drugstore and Pharmacy  
Dry Goods Store

Electrical Appliances, Retail  
Embroidery Shop  
Employment Agency  
Engraver (trophies, jewelry, home plates) (no chemical or sandblasting processes permitted)  
Factory Outlet Store  
Fraternal Association  
Furniture and Home Furnishings, Office and Home, including Retail  
Furs and Leather Goods  
Garden Supplies  
Grocery Store  
Gun Store  
Gunsmith  
Herbs, Retail  
Hotel  
Juice Bar  
Lapidary Service  
Magazine Sales  
Mail Order House  
Mail Services, Parcel Post, Post Boxes  
Market (Mini-Market, Food-Market, Super-Market)  
Mobilehome Sales, (Office)  
Motel  
Motorcycle Sales, Service and Accessories  
Office Supplies  
Optician  
Photographic Finishing, Supplies and Picture Framing  
Pumpkin Sales  
Radio, Stereo Store  
Radio Studio (no antennas)  
Recreational Vehicle and Trailer Sales (including Rental)  
Rubber and Metal Stamp, Retail (shop accessory)  
Satellite Equipment Sales  
Security Service

Stained Glass  
Stamp Shop  
Taxi Cab Stand  
Telephone Sales Office  
Television Repair Store  
Theater  
Wedding Chapel

2. The Accessory Permitted Uses, incidental to Primary Permitted Uses, in the RC District are:

Home Occupation  
Outside Storage, limited by and to subject to Development Standards Division 1 and 1.12 Outside Storage  
Storage containers (temporary) subject to Division 1 and 1.10 Personal Storage of the Development Standards  
Temporary Outdoor Display and Sales subject to Title 18 (Outdoor Sales and Activities)

3. The Conditional Uses in the RC District which require approval of a Special Use Permit are:

Amusement Arcade  
Bar  
Bed and Breakfast Inn (only within the Historic District, and limited to Single Family 6000, Residential Office and Retail Commercial zoning districts, subject to the provisions of Title 18 Development Standards Division 1.7 Bed and Breakfast Inns)  
Building Materials (indoor only)  
Bus Passenger Depot  
Child Care Facility  
Community/Regional Commercial or Office Center  
Congregate Care Housing/Senior Citizen Home  
Facial Cosmetic Shading, Permanent  
Farmers Market  
Funeral Home, Mortuary  
Gaming (unlimited)  
Golf Course and Driving Range  
Hospital  
Hotel Residence

Janitorial and Building Cleaning Service

Kennel

**Medical Marijuana Dispensary or Marijuana Retail Store (subject to the provisions of Title 18 Appendix (Carson City Development Standards), Division 1.20 (Medical Marijuana Establishments and Marijuana Establishments); limited to those areas zoned Retail Commercial within Sections 5, 6 and 8 of Township 15N, Range 20E, north of Winnie Lane, west of Hot Springs Road and south of Medical Parkway and Arrowhead Drive (North Carson Street vicinity).**

Miniature Golf Course

Mobilehome Park

Municipal Well Facility

Newspaper Print Office

Permanent Outdoor Sales subject to Title 18.02.115.8 (Outdoor Sales and Activities)

Personal Storage/Retail/Office Complex subject to Division 1 and 1.10 Personal Storage of the Development Standards

Printer and/or Publisher

Recreational Vehicle Park

Schools, K-12, College, University or Vocational

Single Family, Two-Family and Multi-Family Dwelling

Skating Arena

Storage containers (permanent) subject to Division 1 and 1.10 Personal Storage of the Development Standards

Street Vendors are limited to the DT-MU and RC zoning districts, subject to Division 1 and 1.11 Street Vendors of the Development Standards

Tattoo Parlor

Tennis or Swimming Facility

Trailer or Truck Rental

Utility Substation

Veterinary Clinic

Youth Recreation Facility

## **SECTION II:**

That no other provisions of the Carson City Municipal Code are affected by this ordinance.

PROPOSED on \_\_\_\_\_, 2023.

PROPOSED by \_\_\_\_\_.

PASSED \_\_\_\_\_, 2023.

VOTE:

AYES: \_\_\_\_\_  
\_\_\_\_\_  
\_\_\_\_\_  
\_\_\_\_\_

NAYS: \_\_\_\_\_  
\_\_\_\_\_

ABSENT: \_\_\_\_\_  
\_\_\_\_\_

\_\_\_\_\_  
LORI BAGWELL, Mayor

ATTEST:

\_\_\_\_\_  
WILLIAM SCOTT HOEN, Clerk-Recorder

This ordinance shall be in force and effect from and after the 1st day of the month of \_\_\_\_\_ of the year 2023.

## STAFF REPORT FOR PLANNING COMMISSION MEETING OF JANUARY 25, 2023

FILE NO: ZA-2022-0519

AGENDA ITEM: 6.G

**STAFF CONTACT:** Hope Sullivan, AICP, Community Development Director

**AGENDA TITLE:** For Possible Action: Discussion and possible action regarding a recommendation to the Board of Supervisors (“Board”) concerning an application from Will Adler on behalf of Green Thumb Industries Inc. (“Applicant”) for an ordinance amending location limitations for medical marijuana dispensaries and marijuana retail stores. (Hope Sullivan, [hsullivan@carson.org](mailto:hsullivan@carson.org))

Staff Summary: The Applicant is proposing to amend Carson City Municipal Code (“CCMC”) 18.04.130 to allow marijuana retail stores and medical marijuana dispensaries in the Retail Commercial use district within Township 15N, Range 20, Sections 5, 6 and 8 which is generally the area along North Carson Street north of Winnie Lane and west of Hot Springs Drive.

### PROPOSED MOTIONS:

“I move to recommend to the Board of Supervisors approval of the requested zoning code amendment based on the ability to make the findings as outlined in the staff report.”

**LEGAL REQUIREMENTS:** CCMC 18.02.050 (Review); CCMC 18.02.075 (Zoning map amendments and zoning code amendments); CCMC 18.04.130 (Retail Commercial) and Nevada Revised Statutes (“NRS”) 278.260.

**KEY ISSUES:** Is the request to modify the allowable locations of marijuana retail stores and medical marijuana dispensaries appropriate?

### BACKGROUND:

At its meeting of November 15, 2022, the Planning Commission considered a request to expand where medical marijuana dispensaries and marijuana retail stores could locate. The Planning Commission recommended denial of the request. The applicant has since withdrawn that request and substantially modified the application to still request an expansion, but to a much more limited area.

In 2013 the Medical Marijuana Act was signed into law authorizing Medical Marijuana Establishments (“MMEs”) in Nevada, including dispensaries, cultivation facilities, production facilities, and testing labs. The law also provides local jurisdictions with the right to prohibit or allow these establishments and, if allowed, the ability to regulate the location of MMEs through zoning and business license requirements.

On June 19, 2014 the Board, on first reading, introduced an ordinance allowing for medical marijuana establishments including dispensaries, cultivation and production facilities, and testing laboratories. The ordinance included the requirement for a special use permit (“SUP”) and limitations not only on the zoning districts within which these establishments may be located, but also the specific Sections, Townships, and Ranges where they may be located. On July 3, 2014, the Board adopted the ordinance.

In 2016, Nevada voters passed The Regulation and Taxation of Marijuana Act (codified as NRS Chapter 453D and later amended and recodified as NRS Title 56), legalizing recreational marijuana in Nevada. In 2017, the Board adopted an ordinance to allow for recreational marijuana establishments, including recreational marijuana stores, cultivation and production facilities and testing laboratories. The ordinance mirrored the requirement for the SUP and the locational limitations adopted with the 2014 ordinance.

Medical marijuana dispensaries and marijuana retail stores are limited to the GC and GI use districts. Within the GC zoning district (CCMC 18.04.135(3)) dispensaries are limited to the following:

*“Sections 29 through 32 of Township 15 N., Range 20 E., south of Moses Street (South Carson Street vicinity) and within Sections 1, 2, 9, 10, 11 and 12 of Township 15 N., Range 20 E., and Section 36 of Township 16 N., Range 20 E., east of the I-580 freeway (Highway 50 East vicinity).”*

FIGURE 1: South Carson Street vicinity.

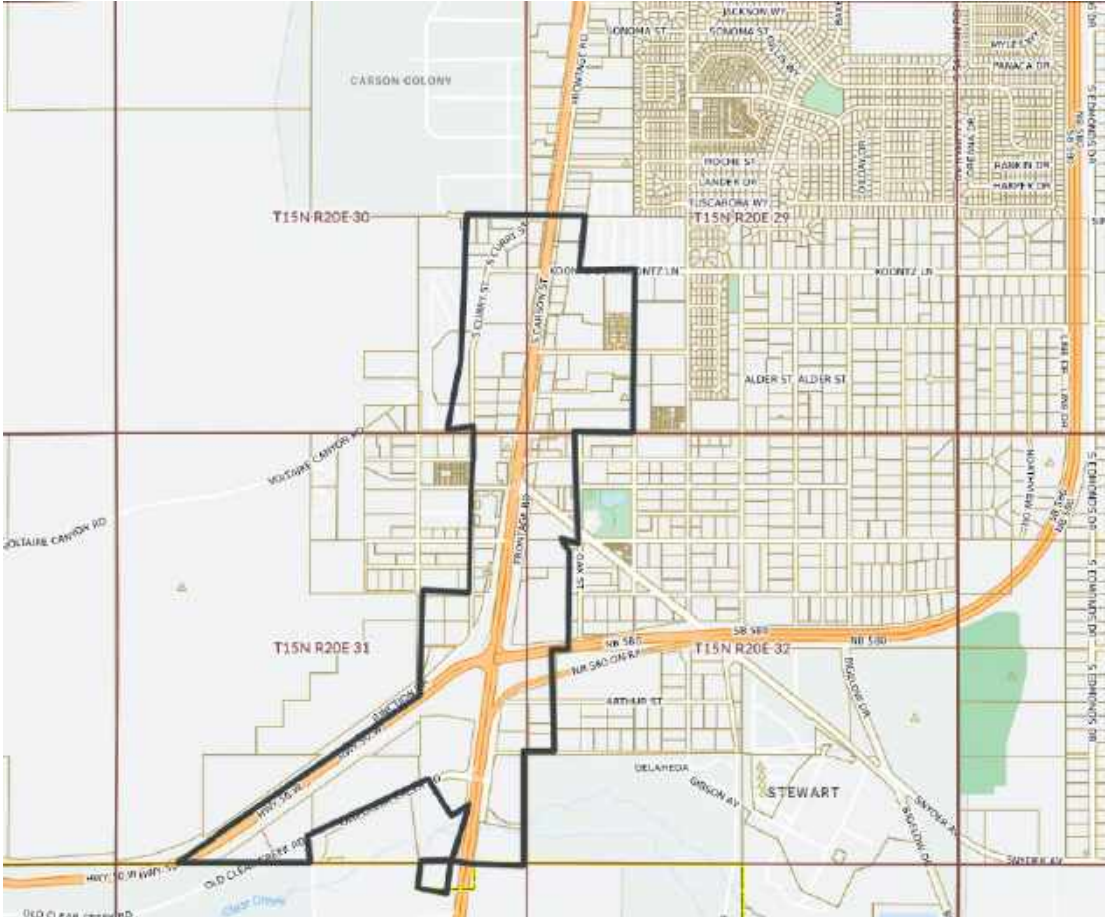

FIGURE 2: Highway 50 E vicinity- GC zoning



Within the GI zoning district (CCMC 18.04.150(3)) dispensaries are limited to the following:

*“Sections 1, 2, 11 and 12 of Township 15 N., Range 20 E., and Section 36 of Township 16 N., Range 20 E (Highway 50 East vicinity).”*

FIGURE 3: Highway 50 E vicinity- GI zoning

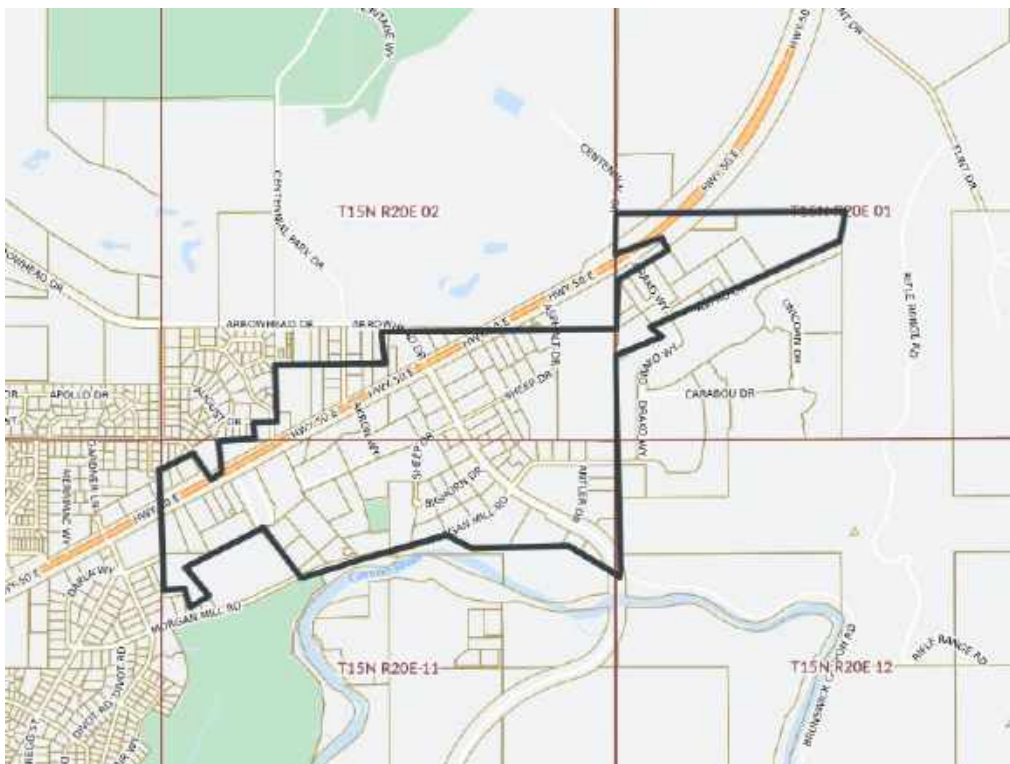



Figures 1 through 3 depict the areas within which a medical marijuana dispensary or a marijuana retail store can be located in the GC and GI zoning districts. There are additional locational limitations found in Carson City Development Standards (“CCDS”) 1.20, regarding distance from preschools and schools, daycares, park and other facilities whose primary service is to provide recreational opportunities to children, and proximity from residential zoning districts. These locational criteria are evaluated at the time of a SUP application.

At its meeting of September 15, 2022, the Board adopted Ordinance 2022-19, allowing for four marijuana retail stores and permitting drive-through services. Although the allowed number of marijuana retail stores was increased from two to four, the locational limitations and requirements have not changed.

**DISCUSSION:**

On June 19, 2014, the Board was considering the zoning regulations related to medical marijuana dispensaries before it had decided if it wanted to opt in or opt out. It did not know what to expect from these dispensaries in terms of impact on the community. It was very concerned about incompatibility with residential uses

During the June 19, 2014 meeting, there was testimony that the business owners seeking to operate medical marijuana dispensaries were only interested in areas on South Carson Street south of Fairview Drive and on Highway 50 west of the 580 interchange. Proponents for allowing medical marijuana dispensaries requested these locational limitations in lieu of the Planning Commission’s recommended 1000 foot separation from churches, parks, playgrounds, daycare facilities or recreational facilities. The Board agreed with the inclusion of the recommended locational criteria in lieu of the 1000 foot separation requirement.

The City now has six years of experience with medical marijuana dispensaries. Through implementation of design standards, they blend in with other community businesses and have not created compatibility issues.

The applicant is seeking to expand where medical marijuana dispensaries and marijuana retail stores can locate. Specifically, the applicant is seeking to expand where they can locate to include locations within the Retail Commercial zoning district within Sections 5, 6 and 8 of Township 15N, Range 20 E, north of Winnie Lane and west of Hot Springs Road.” This area is generally along North Carson Street and depicted on FIGURE 4.

FIGURE 4: PROPOSED EXPANSION AREA

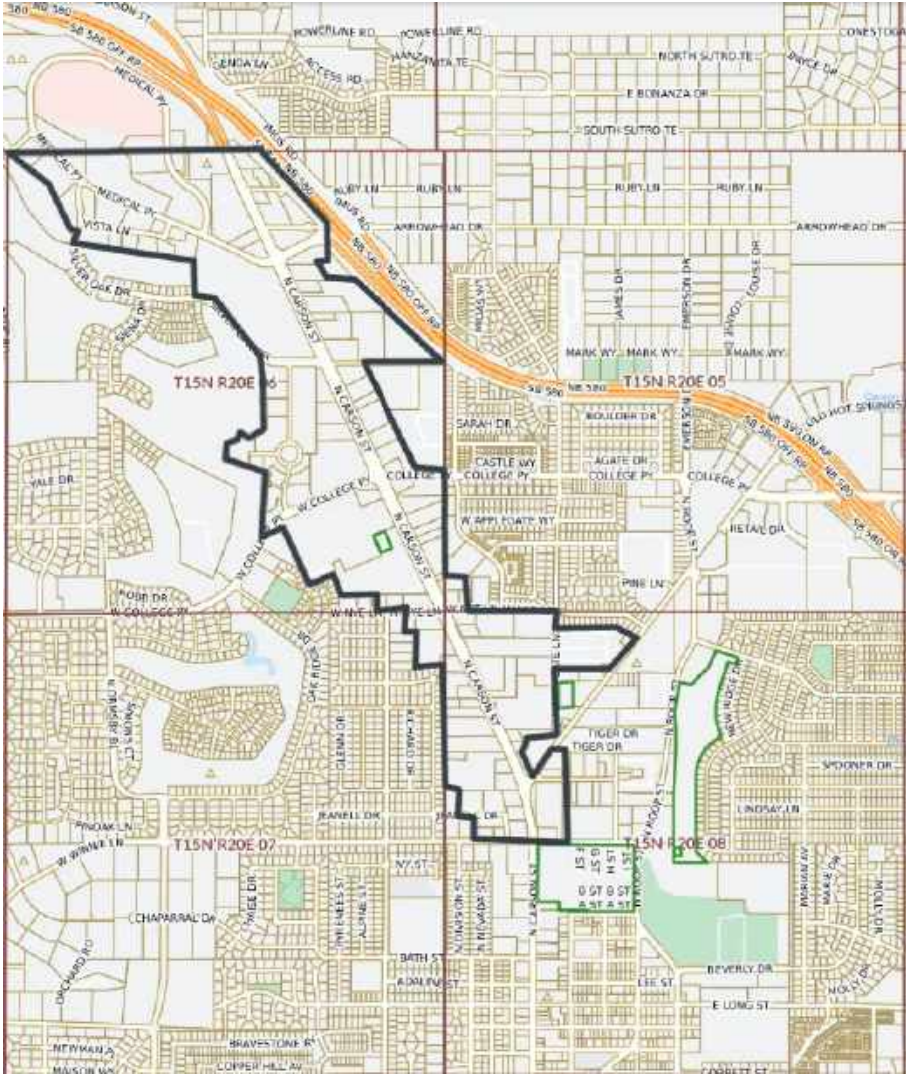

The Board has the authority to approve zoning code amendments following a recommendation from the Planning Commission. In considering a zoning code amendment, the Planning Commission must consider the three required findings as identified in CCMC 18.02.075.

**NOTICING & PUBLIC COMMENTS:**

Noticing was completed consistent with NRS and CCMC. As of the completion of this staff report, no written public comments have been received. Any comments that are received after this report is complete will be submitted prior to or at the Planning Commission meeting, depending on their submittal date to the Planning Division of the Carson City Community Development Department.

**OTHER CITY DEPARTMENTS OR OUTSIDE AGENCY COMMENTS:**

The application was routed to commenting agencies and no comments were received.

**FINDINGS:**

The Planning Commission, in forwarding a recommendation to the Board for approval of a zoning code amendment, shall make all findings of fact found in CCMC 18.02.075(5) in the affirmative. The following findings are recommended by staff:

**1. That the proposed amendment is in substantial compliance with and supports the goals and policies of the Master Plan.**

This finding can be made in the affirmative. Goal 2.3 of the Master Plan encourages the city to provide opportunities for a range of retail services; and Guiding Principle 5: *A Strong Diversified Economic Base* encourages the City to maintain and enhance the base of primary jobs and provide a broader range of retail services to serve residents of Carson City as well as those in surrounding counties.

**2. That the proposed amendment will provide for land uses compatible with existing adjacent land uses and will not have detrimental impacts to other properties in the vicinity.**

This finding can be made in the affirmative. Medical marijuana dispensaries and marijuana retail stores are subject to a SUP. This means that the use can only establish if the Planning Commission can make the seven required finding of fact identified in CCMC 18.02.080 in the affirmative, including the finding that the use:

*“will not be detrimental to the use, peaceful enjoyment, economic value, or development of surrounding properties or the general neighborhood; and is compatible with and preserves the character and integrity of adjacent development and neighborhoods or includes improvements or modification either on-site or within the public right-of-way to mitigate development related to adverse impacts such as noise, vibrations, fumes, odors, dust, glare or physical activity;”*

CCDS 1.20 provides supplemental standards for retail marijuana stores including:

- A single point of entry;
- Hours of operation limited to 8:00 AM to 10:00 PM;
- A 300 foot separation from residentially zoned property as measured on a straight line from the nearest residential property to the front door of the store;
- Adequate lighting and street improvements;
- 1000 feet from a public or private school;
- 300 feet from a facility that provides day care to children, a public park, a playground, a public swimming pool and any other facility the primary purpose of which is to provide recreational opportunities or services to children or adolescents.

If the area where retail marijuana stores are allowed is expanded, the supplemental standards will still apply.

The City has six years of experience with medical marijuana dispensaries and, more recently, retail marijuana stores. At the time the locational criteria was put into place, the City did not know what the impacts of this land use would be. After six years, the two existing dispensaries, which also have retail components, have not been problematic.

**3. That the proposed amendment will not negatively impact existing or planned public services or facilities and will not adversely impact the public health, safety and welfare.**

This finding can be made in the affirmative. The two existing dispensaries / retail stores have not had an adverse impact on public health, safety or welfare. Any new retail store will require a SUP. The SUP can only be issued upon the Planning Commission making each of the seven required findings in the affirmative, including the findings that the use:

*“Will not overburden existing public services and facilities including schools, police and fire protection, water, sanitary sewer, public roads, storm drainage and other public improvements;”*

*and*

*“Will not be detrimental to the public health, safety, convenience and welfare.”*

Therefore, at the time of consideration of a specific SUP, the Commission will have the opportunity to review the request vis-à-vis these findings.

Attachments:

- 1) ZA-2022-0519 application packet
- 2) Public Comment

Carson City Planning Division  
108 E. Proctor Street- Carson City NV 89701  
Phone: (775) 887-2180 • E-mail:

For Office Use Only:

## ZONING CODE AMENDMENT

FILE #

FEE: \$3,250.00 + noticing fee

APPLICANT

Green Thumb Industries Inc.

- Application Form, Written Project Description and Supporting Documentation
- 5 Completed Application Packets (1 Original + 4 Copies)

MAILING ADDRESS, CITY STATE, ZIP

204 S. Minnesota St., Carson City, NV 89703

Application Reviewed and Received By:

PHONE #

FAX #

(775) 230-0247

Submittal deadline: Planning Commission application submittal

EMAIL ADDRESS

will@ssgr.us

Note: Submittals must be of sufficient clarity and detail such that all departments are able to determine if they can support the request. Additional information may be required.

Requested Amendment to Development Standards: \_\_\_\_\_ or Title 18 04.130

Revises provisions of Title 18.04.130 to  
expand locations for marijuana dispensaries.

Required Findings: Title 18 of the Carson City Municipal Code (CCMC) requires that the applicant must present evidence justifying the revision to the Code, that the proposed addition/deletion will be consistent with the objectives of the Master Plan and will not be detrimental to the surrounding properties. A statement relative to findings from Page 2 **MUST** be included herewith, or on an attached sheet.

Please remember that the requested code revision will affect all of Carson City and not only your parcel of land. Present your statement with that in mind. In addition to the brief description of your project and proposed use, provide additional page(s) to show a more detailed summary of your project and proposal.

See attached.

### ACKNOWLEDGMENT OF APPLICANT:

I certify that the foregoing statements are true and correct to the best of my knowledge and belief.

  
Applicant's signature

November 21, 2022

Date

## Cecilia Rice

---

**From:** Hope Sullivan  
**Sent:** Monday, November 28, 2022 3:59 PM  
**To:** Cecilia Rice  
**Subject:** FW: Adjustment to GTI Zoning change application, SSGR

C:  
Please add email to soft file (energov) and hard file for Will's text amendment.

Hope Sullivan, AICP  
Community Development Director  
Carson City, NV  
775-283-7922 (direct)



---

**From:** Will Adler <will@ssgr.us>  
**Sent:** Monday, November 28, 2022 3:48 PM  
**To:** Hope Sullivan <HSullivan@carson.org>  
**Subject:** Adjustment to GTI Zoning change application, SSGR

**This message originated outside of Carson City's email system. Use caution if this message contains attachments, links, or requests for information.**

---

Hope,

In reviewing GTI's application to Carson City's zoning code, I have noticed an error on my part. The language I provided to create a new township section appears incomplete. To be consistent with the map provided I would like to clarify that this range is also supposed to state "west of Hotsprings road." This addition should clarify which township sections are being asked for more clearly.

All the best,

-Will Adler

Principal, Silver State Government Relations  
775.230.0247



Zoning Code Amendment from Green Thumb Industries, Inc.

Submitted by Will Adler

November 22, 2022

## Description of Amendment

The purpose of this amendment is to expand the currently allowed zoning for marijuana dispensaries and Retail Cannabis Stores within Carson City to allow Retail Cannabis Stores to be located within Retail Commercial zoning within Sections 5, 6, and 8 of Township 15 N., Range 20 E. north of Winnie Lane (North Carson vicinity). All other zoning restrictions relating to distance from parks, schools, public facilities, and all other compatibility requirements will remain unchanged. A new retail cannabis store will still have to go through the full special use permit process to show compliance with all State of Nevada and Carson City ordinances regarding the appropriate placement of a retail cannabis store.

This amendment adds a section to Carson City Municipal Code Title 18 to expand locations where a marijuana dispensary/retail cannabis store can be located. We are proposing the addition of a Retail Commercial zoning district to Title 18.04.130 to allow retail cannabis stores to be zoned within limited, retail commercially zoned parcels in North Carson City. The additional space to locate a new Retail Cannabis Store this amendment would provide will help prevent clustering too many Cannabis sales outlets too closely to one another which can create the perception of a cannabis district.

## Justification for Amendment

The Carson City Municipal Code (CCMC 18.02.075) sets out the required findings:

1. That the proposed amendment is in substantial compliance with and supports the goals and policies of the Master Plan.

We believe this amendment will provide the opportunity for the revitalization of areas of Carson City in need of development, and improve shared infrastructure, and security/safety elements. As found in Goal 5.2b of the Master Plan, this amendment will encourage the reuse or redevelopment of unused or underused retail spaces by allowing new retail opportunities to enter those spaces. Additionally, this amendment supports the



Master Plan's goals of continued growth and success of Carson City and can assist with city finances by providing additional tax revenue. Goal 5.8a of the Master Plan encourages the maintenance of a balanced revenue system for business investment. The current zoning restrictions on cannabis establishments runs contrary to Goal 5.8 as its current restrictiveness will encourage the clustering of like cannabis sales establishments, limiting future business investment.

2. That the proposed amendment will provide for land uses compatible with existing adjacent land uses and will not have detrimental impacts to other properties in the vicinity.

The current zoning for retail cannabis stores was established in 2014 when the industrial cultivation and sale of cannabis were an unknown variable to Carson City. As cannabis operations had just begun in Colorado, the impacts of medical marijuana dispensaries were unquantifiable to the Board of Supervisors of 2014. To minimize the chance of unanticipated impacts from medical marijuana dispensaries, the Board of Supervisors of Carson City limited medical marijuana dispensary operations to the limited township ranges it is in today, in two township districts restricted to the eastern and southern portions of Carson City. The ranges allowed in 2014 were chosen to allow additional distance from the more densely populated core of Carson City.

Carson City has now had two successful dispensaries since the 2014 Board of Supervisors' decision to allow cannabis operations. In that time no detrimental impacts have been seen by law enforcement, nor by property owners in the vicinity. The city has had six years with medical cannabis facilities and four years with adult-use cannabis facilities. Those facilities are each located on arterial traffic corridors outside of the commercial core of Carson City and have had no detrimental impact on their surrounding community. The beneficial impact retail cannabis has had goes further than the millions

of dollars Carson City has received in gross revenue and sales tax revenue from Carson City's dispensaries. Businesses located near retail cannabis stores have commented on the benefits of increased security, and higher foot traffic that locating near a cannabis dispensary has provided them with.

Given the success of the 2014 Supervisors' decision, that allowed cannabis operations away from the downtown core of Carson City, GTI petitions to open up a new township zoning district in much the same way. This zoning amendment proposes the addition of a township zoning district in the North end of Carson City. As the North end of Carson City has little GC zoning a request for RC zoning is needed at this time to access commercial property North of Winnie Lane. This is consistent with Carson City's Master Plan as marijuana sales are allowed in Mixed-Use Commercial. The new Retail Commercial district requested in the amendment is also identified in Carson City's Master Plan as Mixed-Use Commercial. This amendment was written to be similar to the zoning intended back in 2014 by expanding the available zoning regions, while keeping all cannabis sales away from the downtown core of Carson City.

It has been suggested that the impact of clustering like cannabis stores would have a detrimental impact of customers transiting back and forth between retail cannabis stores. It has been suggested it would be best to prevent such a situation as it could well produce traffic, law enforcement, and public safety impacts. This amendment seeks to prevent such clusters by enabling a separate geographic area, to allow a new retail cannabis store to open away from Carson City's current retail cannabis stores. This amendment will keep cannabis operations distanced from one another, as they have been spaced since their operations began in 2016.

3. That the proposed amendment will not negatively impact existing or planned public services or facilities and will not adversely impact the public health, safety and welfare.

Through our discussions with law enforcement and other stakeholders, we are confident this amendment will be in alignment with the health and welfare interests of the public, as well as surrounding business and property owners.

### Text of Amendment

Below is the amendment to Title 18.04.130. Sections in bold blue italics are proposed for addition.

#### **18.04.130 - Retail commercial (RC).**

The purpose of the RC District is to preserve a commercial district limited primarily to offices and retail sale of new merchandise and excluding all uses in the General Commercial and Industrial Districts, except for some service uses which are compatible with the zone. All uses within the RC District shall be conducted within a building, and aside from display windows, be screened from view. Outdoor display and storage of autos, recreational vehicles, or mobilehomes in conjunction with an existing business with sales of autos, recreation vehicles and mobilehomes is allowed in accordance with [Division 2](#) of the Development Standards and provided the vehicles or mobilehomes do not encroach into City or State Right-of-Way without an approved encroachment permit and are screened from adjacent parcels. Temporary outdoor display and sale of merchandise for a period not to exceed 30 days within a calendar year may be authorized by the Director subject to Title 18.02.115.8 (Outdoor Sales and Activities).

...

3. The Conditional Uses in the RC District which require approval of a Special Use Permit are:

- Amusement Arcade
- Bar
- Bed and Breakfast Inn (only within the Historic District, and limited to Single Family 6000, Residential Office and Retail Commercial zoning districts, subject to the provisions of Title 18 Development Standards Division 1.7 Bed and Breakfast Inns)
- Building Materials (indoor only)
- Bus Passenger Depot
- Child Care Facility
- Community/Regional Commercial or Office Center
- Congregate Care Housing/Senior Citizen Home
- Facial Cosmetic Shading, Permanent
- Farmers Market
- Funeral Home, Mortuary

- Gaming (unlimited)
- Golf Course and Driving Range
- Hospital
- Hotel Residence
- Janitorial and Building Cleaning Service
- Kennel
- *Medical Marijuana Dispensary or Marijuana Retail Store subject to the provisions of Title 18 Appendix (Carson City Development Standards), Division 1.20 (Medical Marijuana Establishments and Marijuana Establishments), limited to those areas zoned Retail Commercial within Sections 5, 6, and 8 of Township 15 N., Range 20 E. north of Winnie Lane (North Carson vicinity)*
- Miniature Golf Course
- Mobilehome Park
- Municipal Well Facility
- Newspaper Print Office
- Permanent Outdoor Sales subject to Title 18.02.115.8 (Outdoor Sales and Activities)
- Personal Storage/Retail/Office Complex subject to Division 1 and 1.10 Personal Storage of the Development Standards
- Printer and/or Publisher
- Recreational Vehicle Park
- Schools, K-12, College, University or Vocational
- Single Family, Two-Family and Multi-Family Dwelling
- Skating Arena
- Storage containers (permanent) subject to Division 1 and 1.10 Personal Storage of the Development Standards
- Street Vendors are limited to the DT-MU and RC zoning districts, subject to Division 1 and 1.11 Street Vendors of the Development Standards
- Tattoo Parlor
- Tennis or Swimming Facility
- Trailer or Truck Rental
- Utility Substation
- Veterinary Clinic
- Youth Recreation Facility





**Of the commercial property available in Carson City**

**Only 3 could be found that met Carson City's and the States's Zoning requirements**

**All Three are in this circle**

**This area is currently prohibited under Carson City's Current Zoning Restrictions**

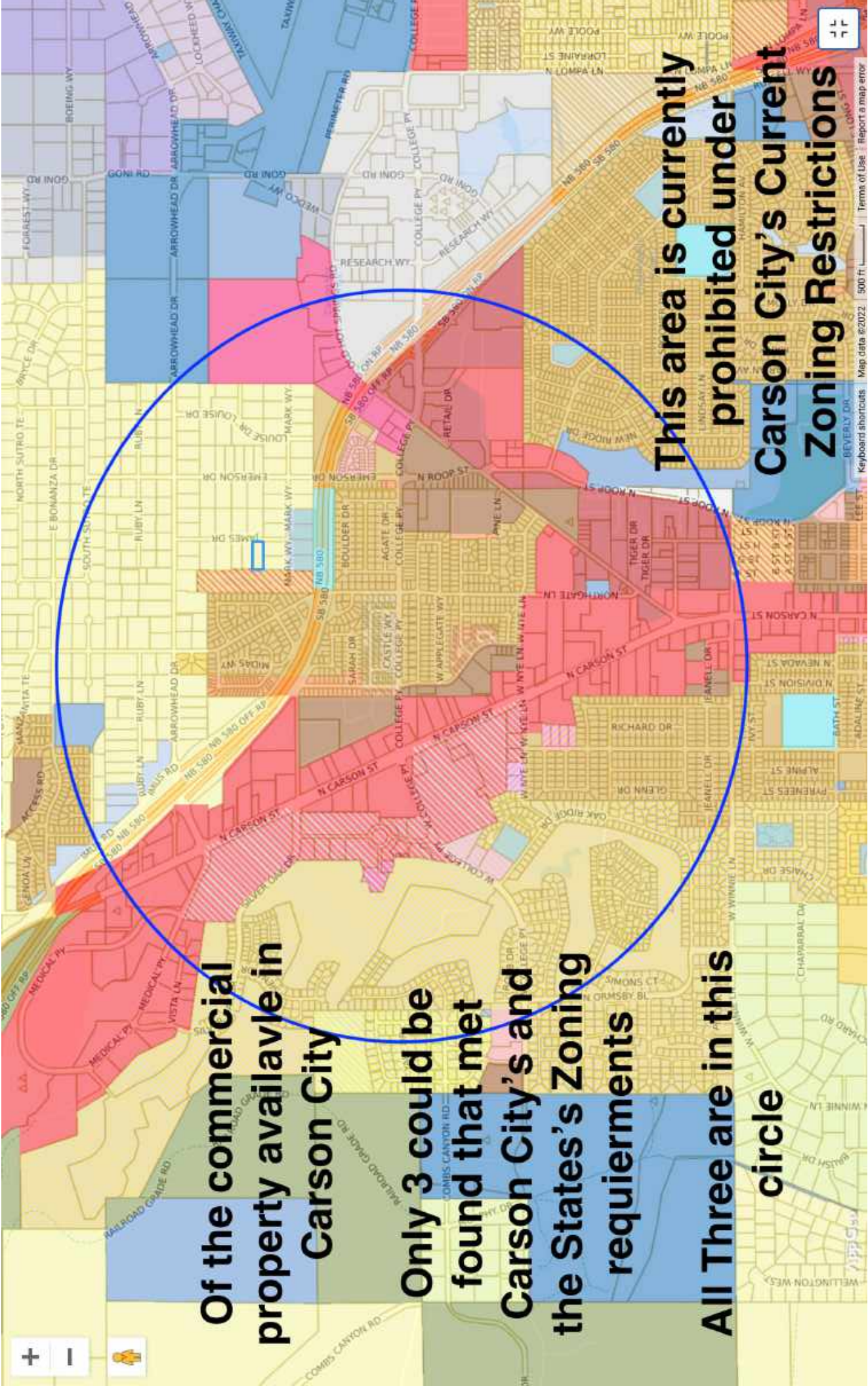

Keyboard shortcuts Map data ©2022 500 Ft. Report a map error



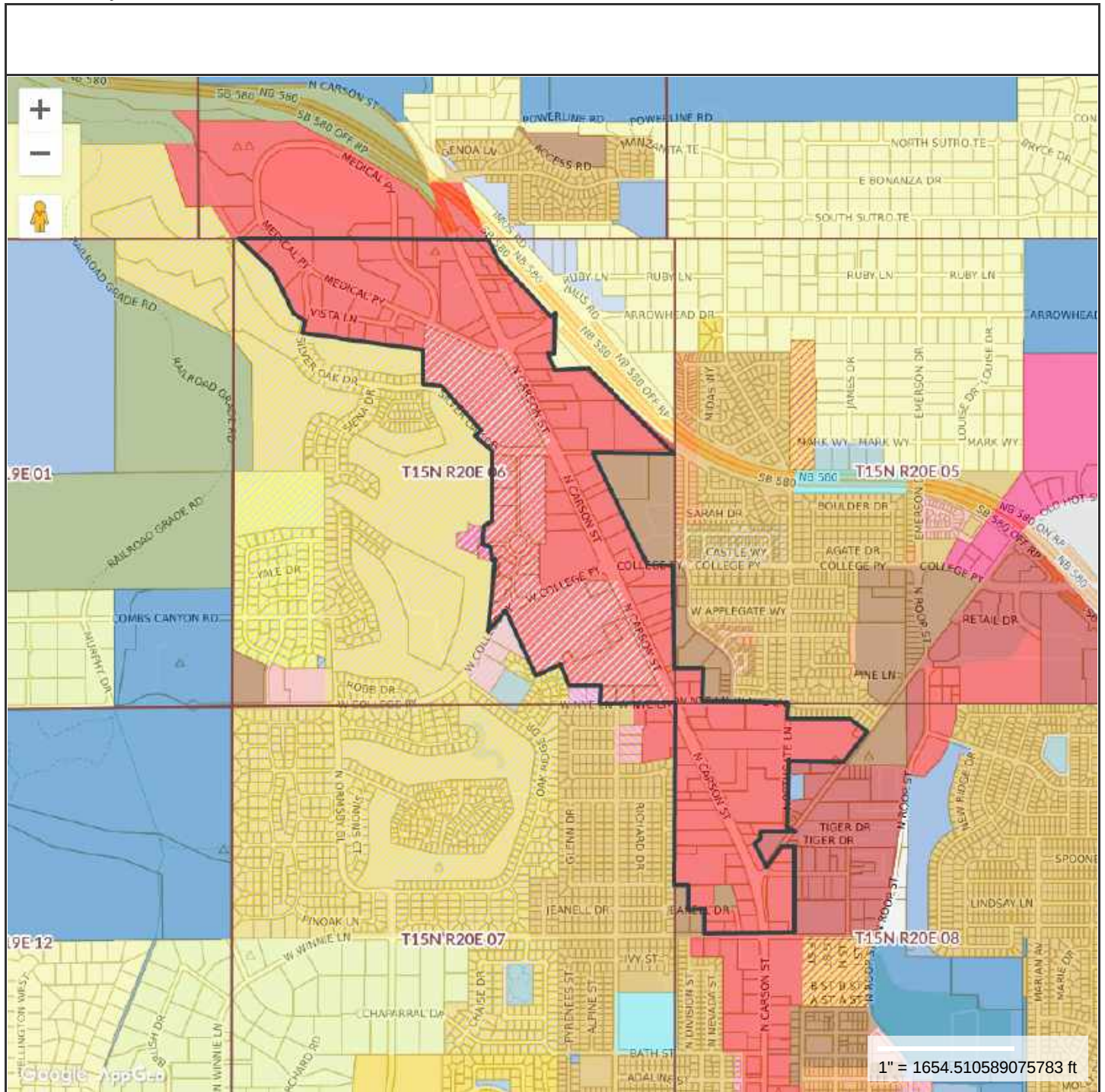

**MAP FOR REFERENCE ONLY  
NOT A LEGAL DOCUMENT**

Carson City , NV makes no claims and no warranties, expressed or implied, concerning the validity or accuracy of the GIS data presented on this map.

Geometry updated 11/17/2018  
Data updated 11/17/2018

Print map scale is approximate. Critical layout or measurement activities should not be done using this resource.

## Cecilia Rice

---

**From:** Michael Goldeen <magoldeen@earthlink.net>  
**Sent:** Sunday, December 18, 2022 10:10 AM  
**To:** Planning Department  
**Subject:** Green Thumb Industries Latest Request

**This message originated outside of Carson City's email system. Use caution if this message contains attachments, links, or requests for information.**

---

I see in the news that Green Thumb Industries now wants you to allow marijuana retail outlets and medical dispensaries in the retail commercial zone along North Carson St. north of Winnie Lane, and West of Hot Springs Road. This sounds like what they wanted in first place, and their recently denied request for a blanket zoning change was just to prime the pump. But really has there been any change in the circumstances which prompted your original decision to allow them only along a portion of South Carson St.?

As Robert Cialdini, whose work you may be acquainted with, observes, "The truly gifted negotiator, then, is one whose initial position is exaggerated enough to allow for a series of concessions that will yield a desirable final offer from the opponent (that's you), yet is not so outlandish as to be seen as illegitimate from the start." The message here seems to be take each request on its face value without regard to what may have gone before.

Thank you for your consideration of my note.

Michael Goldeen  
804 Lexington Avenue  
Carson City, NV 89703

775-297-3688  
michael@goldeen.com



1000 N. Division Street 202  
Carson City, NV 89703  
NAIalliance.com

December 18th, 2022

Chair Wiggins and the Carson City Planning Commission,

NAI Alliance Carson City would like to take this opportunity to inform the Carson City Planning Commission of our efforts to locate a suitable zoned location for a new retail cannabis store. As the Planning Commission is aware, the Carson City Board of Supervisors recently doubled the number of retail cannabis stores at their September 15, 2022 meeting. As such, our client (Green Thumb Industries, Inc.) has found themselves in need of a dispensary location for their second, yet to be perfected, license in Carson City.

To accomplish this, we've gone through an extensive search of all the general and retail commercial properties in Carson City and have discovered no commercially viable locations within Carson City's currently allowed general commercial zoned areas for cannabis. Currently, several properties have been located, but all of them fall outside of Carson City's allowable township zoning region for retail cannabis stores. To rectify the lack of property, we'd ask the Carson City Planning Commission to allow the changes asked for in GTI's zoning change request to move forward, as they would open up additional retail properties in the north end of town where the majority of viable retail locations are located to date.

Sincerely,

Rocky Joy  
Broker/Salesman  
NAI Alliance Carson City

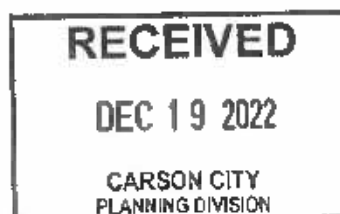



**LATE  
MATERIAL  
6.G**



301 West Washington Street  
Carson City, Nevada 89703  
775.884.1896 O  
775.884.4896 F  
www.nvcg.us

January 24, 2023

Chair Wiggins and the Carson City Planning Commission,

Nevada Commercial Group would like to take this opportunity to inform the Carson City Planning Commission of our efforts to locate a suitable zoned location for a new retail cannabis store. As the Planning Commission is aware, the Carson City Board of Supervisors recently doubled the number of retail cannabis stores at their September 15, 2022 meeting. As such, our client (Green Thumb Industries, Inc.) has found themselves in need of a dispensary location for their second, yet to be perfected, license in Carson City.

To accomplish this, we've gone through an extensive search of all the general and retail commercial properties in Carson City and have discovered no commercially viable locations within Carson City's currently allowed general commercial zoned areas for cannabis. Currently, several properties have been located, but all of them fall outside of Carson City's allowable township zoning region for retail cannabis stores. To rectify the lack of property, we'd ask the Carson City Planning Commission to allow the changes asked for in GTI's zoning change request to move forward, as they would open up additional retail properties in the north end of town where the majority of viable retail locations are located to date.

Sincerely,

A handwritten signature in blue ink, appearing to read "Rocky Joy", is written over a light blue circular stamp.

Rocky Joy

Broker/Salesman

Nevada Commercial Group



# GreenThumb Industries

December 20, 2022



Green Thumb is a leading national cannabis consumer packaged goods company and retailer.

Founded in 2014, GTI has over 75 retail locations, employs approximately 4,000 people and serves millions of patients and customers each year.

We are proud to serve patients and customers across the nation!





Green Thumb is the owner and operator of RISE dispensaries.

RISE Carson City opened September 8, 2016 and was the first medical cannabis dispensary opened by Green Thumb in Nevada.

Green Thumb now operates a total of 4 RISE locations across the state: Carson City, Henderson, Reno, and Spanish Springs.





# OPENING DAY RISE CARSON CITY

September 8, 2016





# Supporting our NV Community

Our **Round Up** campaign supports local non-profit organizations through contributions received from RISE customers that “round up” to the nearest dollar when making a purchase.

- Raised over **\$260K** since Round Up launch in 2021
- Recipients:
  - Make the Road NV (Current)
  - Helping Our Brothers and Sisters

Women’s History Month **Feminine Hygiene Drive** across Carson City, Reno, and Las Vegas benefitting **local domestic violence shelters**

- Carson City recipient: Advocates to End Domestic Violence



# Supporting our Carson City Community

- Local, employee-led volunteering:
  - Healthy Communities Coalition – monthly
  - Reno Pride Parade – first annual (committed for 2023!)
  - Vitalant Blood Donation – quarterly
  - Carson City Senior Center and Food Kitchen, a meals-on-wheels partner – new partner committed for 2023
- Support for the Boys and Girls Club of Western Nevada
  - Kahuna Sponsor (\$12,500) – 4 years running





# Retail Cannabis's Rigorous Requirements

- **Security**
  - 24/7 camera surveillance
  - Secure ID validation for all visitors and contractors.
  - Product in child-proof containers, barcoded and labeled with safety warnings, traceability and inventory management, Seed to Sale tracking
- **What it takes to build a store**
  - Compliance with all state/local building code emphasizing safety and security
  - Final inspection prior to opening, annual inspections and routine State audits
- **Economic Investment in Building the Store**
  - Roughly \$1M construction investment into a vacant or underutilized site.
  - Roughly 15-20 full and part time employees
  - Tax revenue, 3% of gross sales go directly to Carson City

# Maps – Current Zoning

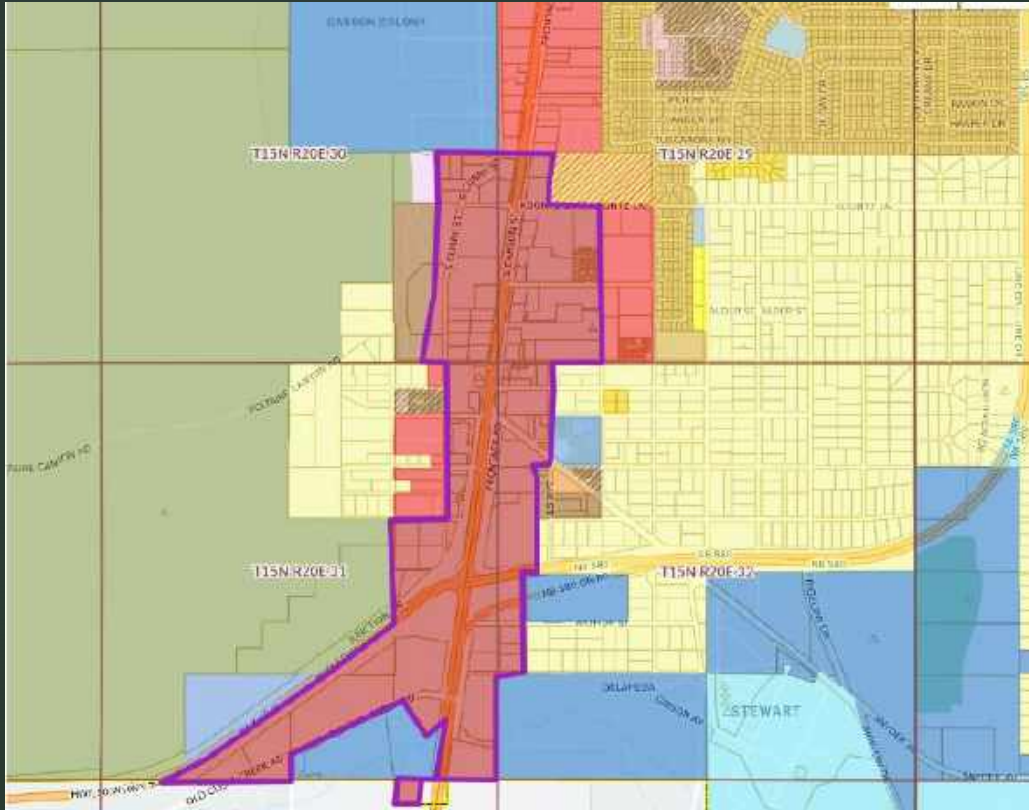

South Carson Street Vicinity



Highway 50 East Vicinity

# South Carson Street Vicinity with bubbles following NRS 678B.250

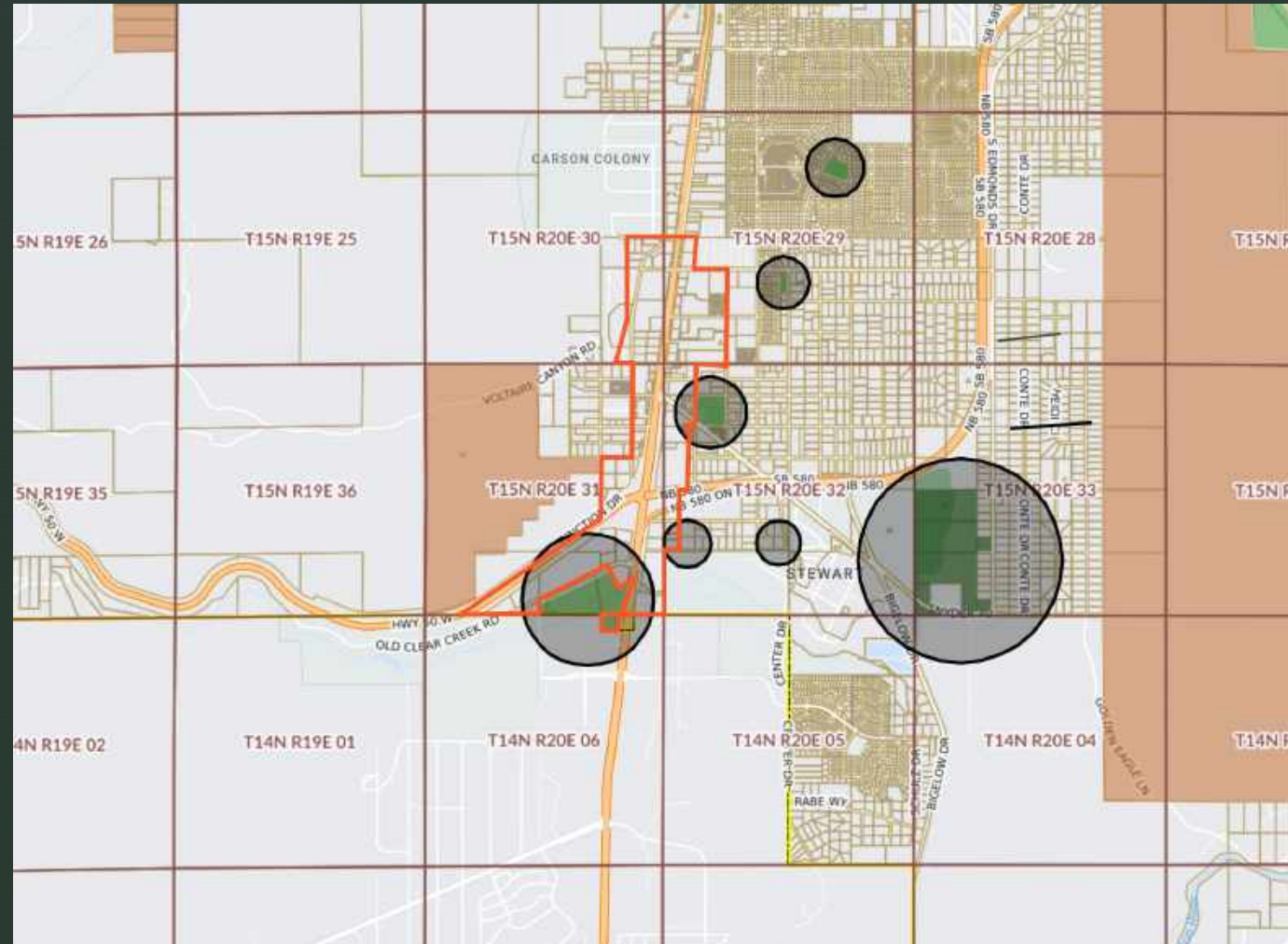



# Highway 50 E Vicinity with bubbles following NRS 678B.250



# Maps - Proposed

- North Carson Vicinity
- North of Winnie Lane along Hwy 395

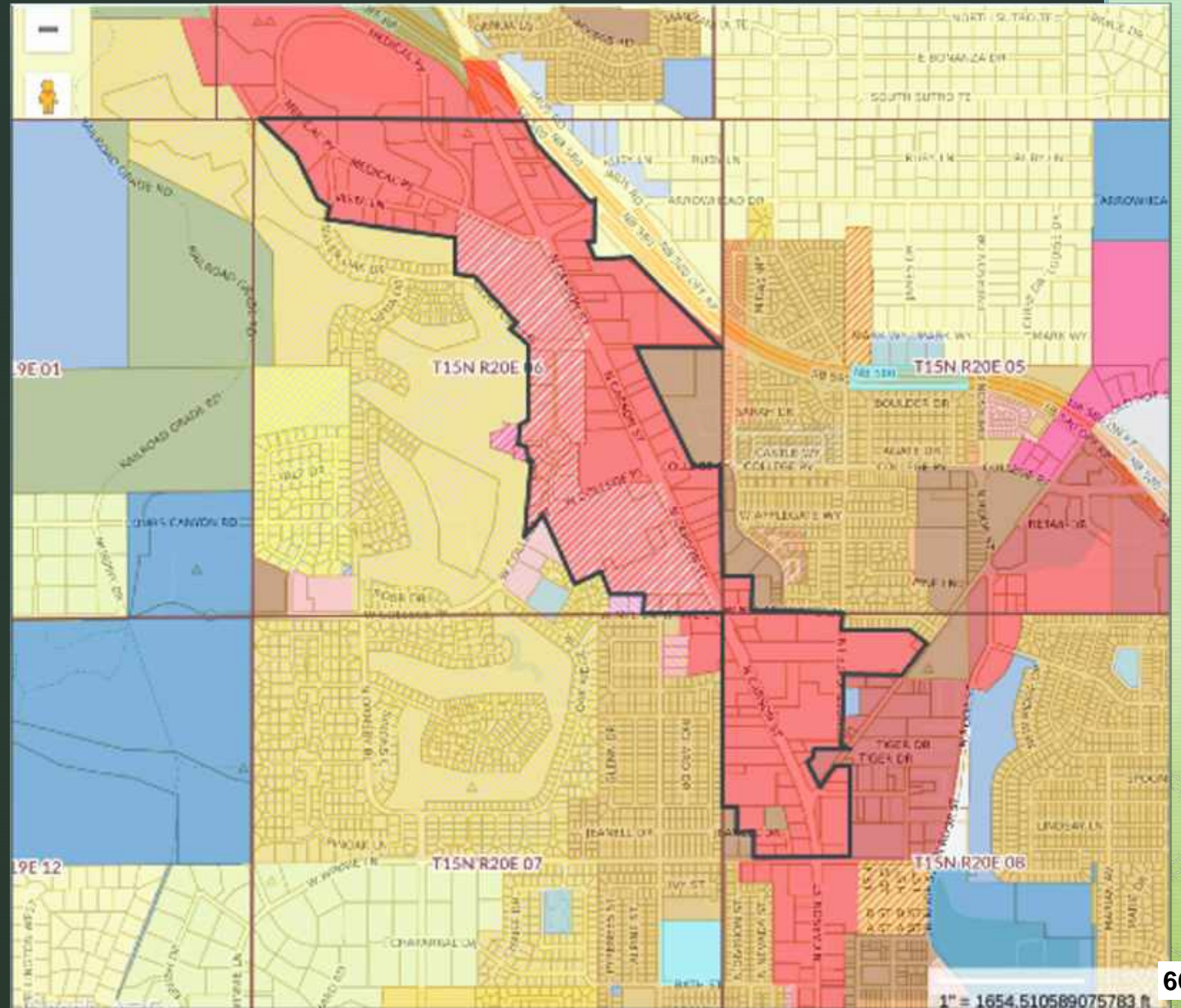



# Bubbles include zoning following NRS 678B.250

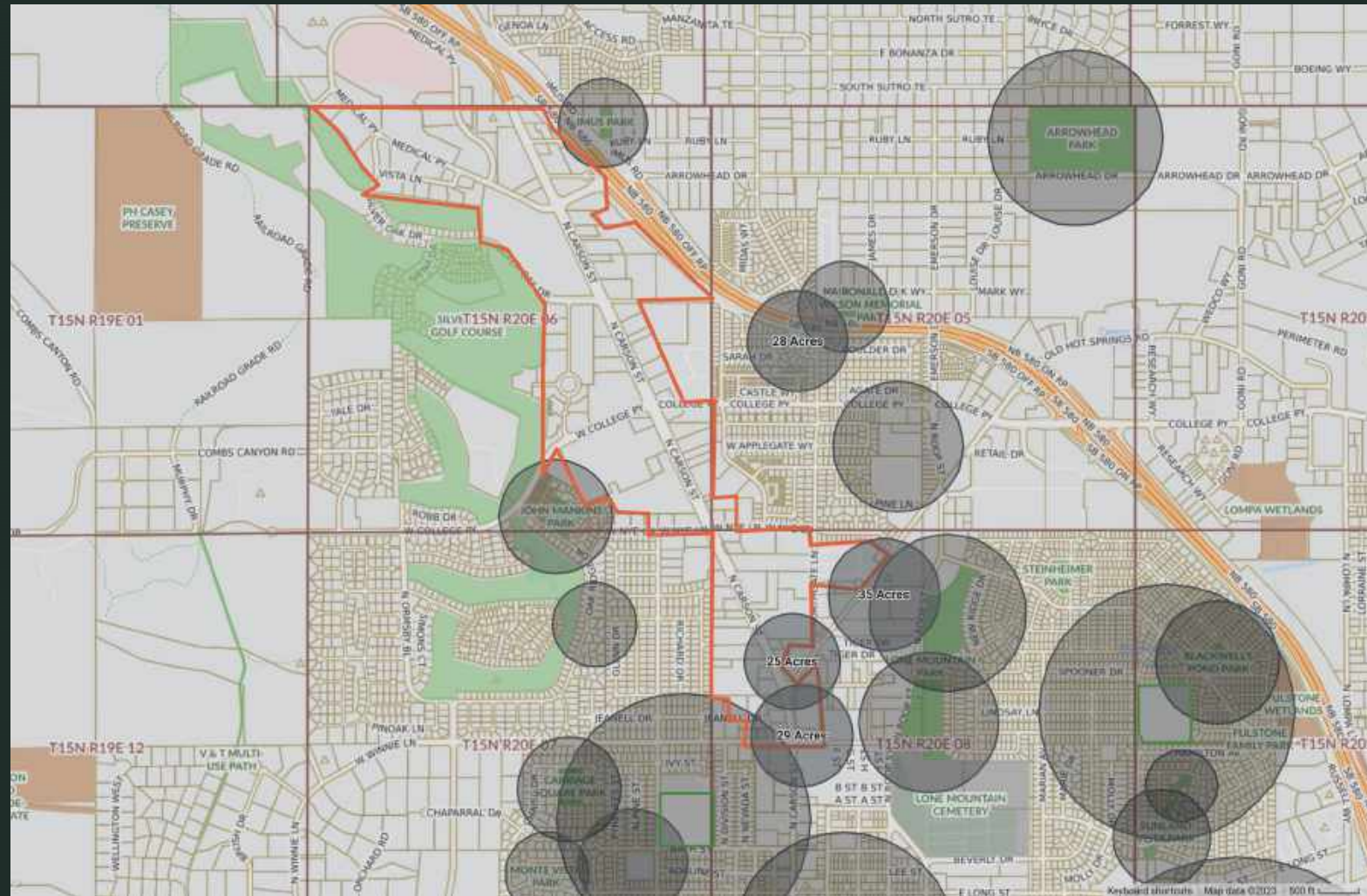

# Thank You

Will Adler

Silver State Government Relations

On behalf of GTI, Inc.

News never stops. Neither do we. Support MassLive.com

News

# Northampton marijuana shop The Source closes; 1st shutdown for state's cannabis industry

Updated: Dec. 14, 2022, 8:37 a.m. | Published: Dec. 13, 2022, 4:59 p.m.



A sign points out onto Pleasant Street in Northampton from the entranceway of The Source dispensary. The store opened in Spring 2022. (Will Kothari/MassLive)



The Source, a marijuana shop at 58 Pleasant St. in Northampton that opened only in March, will close Friday.

It's the first marijuana shop in Massachusetts to shut down since the first legal adult use dispensaries opened in 2018. Many in the industry see this as a harbinger of a shakedown in a maturing industry, especially in Northampton which has 12, soon to be 11, operational stores.

Seven pot shops, including The Source, are within blocks of each other.

The shop has 16 employees, according to workers there who referred to Brett Sprau, general manager of The Source.

The Source is operated by Just Healthy LLC, according to documents on file at the Massachusetts Cannabis Control Commission, and is run by a multi-state operator based in Las Vegas.

In October, Northampton Mayor Gina-Louise Sciarra turned down the application of [Euphorium](#), a dispensary that wanted to open across town in the Florence section of Northampton. Her decision was sparked, in part, by fears of too much competition.

Tuesday, Matt Yee, chief operating officer of competitor Enlite Cannabis Dispensary, 391 Damon Road, said there were contractions in other legalized marijuana markets with shops closing in Colorado, Washington state and California as the industry matured.

"It's going to be an interesting year in 2023," he said.

Massachusetts cannabis retailers have [done \\$3.8 billion](#) in business since the first legal dispensaries opened in November of 2018. Year to date sales have totaled \$1.34 billion.

The Cannabis Control Commission told the Boston Business Journal that two other recreational marijuana retailers surrendered licenses when owners merged. Owners are limited to just three locations.

The Northampton Mayor's office did not return a call for comment.

*Material from the Boston Business Journal was used in this story.*

If you purchase a product or register for an account through one of the links on our site, we may receive compensation.

---

---

# ADVANCELOCAL

Registration on or use of this site constitutes acceptance of our [User Agreement](#), [Privacy Policy and Cookie Statement](#), and [Your California Privacy Rights](#) (User Agreement updated 1/1/21. Privacy Policy and Cookie Statement updated 7/1/2022).

## **Do Not Sell My Personal Information**

© 2023 Advance Local Media LLC. All rights reserved ([About Us](#)).

The material on this site may not be reproduced, distributed, transmitted, cached or otherwise used, except with the prior written permission of Advance Local.

[Community Rules](#) apply to all content you upload or otherwise submit to this site.

[Ad Choices](#)

LATE MATERIAL  
PASSED OUT TO PL. COMMISSION  
1.25.23

**ZA\_2022-0519 – Public Comment opposing expansion of marijuana dispensaries and retail stores  
Betsy Strasburg**

Per CCMC 18.02.075:

**A Zoning Map Amendment or Zoning Code Amendment may be initiated by a majority of the Commission or Board, or an owner of real property. The Director shall investigate each application to assure that the proposal is consistent with the requirements of this title.**

**This application do not show ownership of any parcel. The Planning Dept. and the DA's office have stated that have reviewed Mr. Adler's application and feels that it satisfies the requirement of ownership. We, the taxpayers, have a right to know as do you, Commissioners, that the first condition of an ordinance change has been met. It is public disclosure of staff findings. Please address this first. If this is not correctly applied, the rest of the discussion is moot.**

1. Board of Supervisors approved the increase from 2 to 4 marijuana stores reliant on the other existing codes. Supervisor Giomi made a motion to require the DA's office to look at the regulations. Had it not been the need for expediency desired by the Mayor and the hesitancy of the DA's office to commit to a quick turnaround due to resource constraints, the motion would not been withdrawn.
2. The 6 supplementary standards w.r.t Marijuana stores are inadequate. Example: 300 feet from a residential property is insufficient.
3. Just because the Planning commission can vote on a SUP should not be used as a justification to expand location limitations, equivalent to kicking the ball down the road, without due consideration of additional regulations. This justification is used for condition 2 and 3.
4. State Regulations do not surpass local regulations – Douglas County has no marijuana stores.
5. There are no basis to say that 6 years of experience sufficient? The Sheriff has provided testimony that he had no problems with the two marijuana stores. He did not, and cannot, testify on the impact of marijuana on our community. There are no tests to detect marijuana. The Legislature has conducted a meeting on marijuana usage among pregnant women. There is trend towards high potency marijuana. **With all these factors, to say 6 years is sufficient to determine adverse impact on public health, safety or welfare under condition 3 is far-reaching.** We do not need to be leading edge of experimentation in our community.
6. The entire Carson Street corridor from Winnie to Medical Parkway is used for the expansion zone to avoid being a cluster of cannabis stores. How can there be a cluster when marijuana stores are 1 to 2 miles apart. Just as Supervisor White and Jones said that they should not protect profitability of existing marijuana stores by **NOT increasing the # of stores.** The City should not eliminate location limitations to protect profitability as well.
7. **I request the Commission to reject this application until the DA's office can provide additional regulations to protect the community as Supervisor Giomi was trying to do and only if the applicant is an owner of a parcel and can request an ordinance change.**



## STAFF REPORT

**Report To:** Board of Supervisors      **Meeting Date:** March 2, 2023

**Staff Contact:** Nancy Paulson, City Manager

**Agenda Title:** For Possible Action: Discussion and possible action regarding coordination of legislative activity on pending state legislation before the Nevada Legislature and whether to adopt an official policy position or direct staff to advocate for or against any such legislation, including the submittal of proposed amendatory language. (Stephen Wood, [swood@carson.org](mailto:swood@carson.org) and Nancy Paulson, [npaulson@carson.org](mailto:npaulson@carson.org))

Staff Summary: The Nevada Legislature is currently in its 82nd Regular Session. This item is for the Board of Supervisors to coordinate legislative efforts on pending state legislation that may have an impact on Carson City, including the adoption of official policy positions, if any, and direction to staff to advocate for or against any such legislation. Due to unpredictable timing constraints inherent in the legislative process, the City will maintain a list of legislation that the City has identified in advance and which may be discussed and acted on by the Board during this agenda item. A copy of the list will be posted not less than three days before the date of each Board of Supervisors meeting during which this agenda item appears and may be obtained at the following Internet website: <https://www.carson.org/legislature>.

**Agenda Action:** Formal Action / Motion      **Time Requested:** 10 min

---

### **Proposed Motion**

Depends on discussion.

### **Board's Strategic Goal**

Efficient Government

### **Previous Action**

February 16, 2023 (Item 21A): The Board of Supervisors voted to oppose Assembly Bill No. 14.

January 19, 2023 (Item 13A): The Board of Supervisors reviewed Resolution No. 2020-R-23 which establishes policies for the coordination and communication of legislative matters during Regular and Special Sessions of the Nevada Legislature.

### **Background/Issues & Analysis**

With the 82nd Regular Session of the Nevada Legislature underway, this agenda item is for the Board of Supervisors to consider pending legislation before the Legislature and to coordinate efforts to formulate official policy positions and to direct staff to advocate for or against such legislation. Because the state legislative process is such that it is difficult, if not impossible at times, to predict when a legislative measure will be introduced or heard by a legislative committee for passage and approval, the City will maintain and keep current

as much as possible a list of legislative measures that have been identified and which may be discussed and acted on by the Board of Supervisors. However, there may be circumstances where the introduction of a bill or proposed amendment to a bill occurs after publication of the Board of Supervisors agenda and without opportunity to identify the bill or amendment on the City's list, including bills or amendments that the City becomes aware of on the day of a Board of Supervisors meeting, but the bill should be discussed or acted on because postponing discussion or action until the next meeting of the Board could render any delayed discussion or action obsolete.

**Applicable Statute, Code, Policy, Rule or Regulation**

Resolution No. 2020-R-23; Schmidt v. Washoe County, 123 Nev. 128 (2007)

**Financial Information**

**Is there a fiscal impact?** No

**If yes, account name/number:**

**Is it currently budgeted?**

**Explanation of Fiscal Impact:**

**Alternatives**

**Attachments:**

**Board Action Taken:**

Motion: _____	1) _____	Aye/Nay
	2) _____	_____
		_____
		_____
		_____

\_\_\_\_\_  
(Vote Recorded By)

**CARSON CITY BOARD OF HEALTH**  
**Minutes of the December 15, 2022 Meeting**  
**Page 1**

**DRAFT**

A meeting of the Carson City Board of Health was held during the regularly scheduled Carson City Board of Supervisors meeting on Thursday, December 15, 2022, in the Community Center Robert “Bob” Crowell Boardroom, 851 East William Street, Carson City, Nevada.

**PRESENT:**

Chairperson Dr. Colleen Lyons  
Vice Chair Stacey Giomi  
Member Lori Bagwell  
Member Ken Furlong  
Member Stan Jones  
Member Lisa Schuette  
Member Maurice White

**STAFF:**

Nancy Paulson, City Manager  
Stephanie Hicks, Deputy City Manager  
Dan Yu, Assistant District Attorney  
Tamar Warren, Senior Public Meetings Clerk

**NOTE:** A recording of these proceedings, the board’s agenda materials, and any written comments or documentation provided to the Clerk during the meeting are part of the public record. These materials are on file in the Clerk’s Office, and available for review during regular business hours.

**23. CALL TO ORDER & ROLL CALL - BOARD OF HEALTH**

(11:52:34) – Chairperson Lyons called the Board of Health to order at 11:52 a.m. Ms. Warren called roll and noted the presence of a quorum.

**24. PUBLIC COMMENT**

(11:53:07) – Chairperson Lyons entertained public comments. Deni French introduced himself and inquired whether the Health Department had an increase in cold-related incidents, especially in the homeless population. Chairperson Lyons explained that the Nights Off the Streets (NOTS) program had been successful in preventing them.

**25. FOR POSSIBLE ACTION: APPROVAL OF MINUTES - AUGUST 18, 2022**

(11:54:10) – Chairperson Lyons introduced the item and noted an error in the form of an incomplete sentence, which has since been corrected. She also entertained additional comments and/or a motion.

**(11:55:32) – Member Bagwell moved to approve the minutes of the August 18, 2022 Board of Health meeting as amended. The motion was seconded by Member White and carried 7-0-0.**

**26. HEALTH AND HUMAN SERVICES**

**CARSON CITY BOARD OF HEALTH**  
**Minutes of the December 15, 2022 Meeting**  
**Page 2**

**DRAFT**

**26. A FOR POSSIBLE ACTION: DISCUSSION AND POSSIBLE ACTION REGARDING THE PROPOSED ACCEPTANCE OF A REPORT OF THE CARSON CITY HEALTH OFFICER.**

(11:55:52) – Chairperson Lyons introduced the item and presented her report, incorporated into the record, as of August 15, 2022, which included the influenza activity for the 2022-2023 season. She also encouraged vaccinations to prevent life-threatening hospitalizations. Additionally, Chairperson Lyons recommended receiving immediate treatment for fevers and cold symptoms to ensure the appropriate mitigation. She highlighted the increase in the poverty rate of adults over the age of 65, noting that 118 additional seniors would suffer from poverty in Carson City based on the statistics. She recommended being cautious, especially regarding children suffering from a respiratory virus for which a vaccine was not available. Chairperson Lyons entertained public comments and when none were forthcoming, a motion.

**(12:03:03) – Vice Chair Giomi moved to accept the report as presented. Member Furlong seconded the motion.**

<b>RESULT:</b>	<b>APPROVED (7-0-0)</b>
<b>MOVER:</b>	Vice Chair Giomi
<b>SECONDER:</b>	Member Furlong
<b>AYES:</b>	Members Bagwell, Furlong, Jones, Schuette, White, Vice Chair Giomi, and Chair Lyons
<b>NAYS:</b>	None
<b>ABSTENTIONS:</b>	None
<b>ABSENT:</b>	None

**26.B FOR DISCUSSION ONLY: DISCUSSION AND PRESENTATION REGARDING THE REGIONALIZATION OF PUBLIC HEALTH IN NEVADA.**

(12:04:23) – Chairperson Lyons introduced the item. Carson City Health and Human Services Director Nicki Aaker gave background regarding the Central Nevada Health District (CNHD) that had been approved on December 2, 2022 by the Nevada Board of Health to become a Nevada health district.

(12:05:24) – Taylor Allison, Public Health Coordinator, Nevada Association of Counties, reviewed a presentation on public health jurisdictions and services, incorporated into the record, and responded to clarifying questions. Chairperson Lyons explained that due to its fast expansion, Lyon County could be eligible to form its own health district in the future based on anticipated growth. Ms. Allison noted that a report to review the socioeconomic impact would be available in June 2023 and recommended conducting a foundational public health assessment. Chairperson Lyons indicated that the COVID-19 pandemic had exposed many inadequacies, including small and local boards of health. Additionally, she thanked the Board of Supervisors for allowing the expansion of the City’s Epidemiology team that provides assistance to Douglas County “under contract.”

**CARSON CITY BOARD OF HEALTH**  
**Minutes of the December 15, 2022 Meeting**  
**Page 3**

**DRAFT**

(12:19:25) – Ms. Aaker explained that Carson City is defined as a “health authority” and not a “health district” because “we do not have two public entities,” adding that they work closely with entities that have larger populations. She highlighted an interlocal agreement for environmental health with Douglas County and a grant-funded delegation of authority through the State for disease surveillance. Ms. Aaker noted that the grant-funded tobacco prevention and adolescent health programs were also part of a multi-county collaborative effort, adding that the quad-county COVID response had been robust due to the public health preparedness grant. Chairperson Lyons believed that regionalization helped understand local issues and respond using regional resources. Ms. Aaker also responded to clarifying questions. This item was not agendaized for action.

**26.C FOR POSSIBLE ACTION: DISCUSSION AND POSSIBLE ACTION REGARDING A PROPOSED ACCEPTANCE OF THE REPORT OF THE DIRECTOR OF THE CARSON CITY DEPARTMENT OF HEALTH AND HUMAN SERVICES (“CCHHS”).**

(12:33:53) – Chairperson Lyons introduced the item. Ms. Aaker presented her report, incorporated into the record, and responded to clarifying questions. Discussion ensued regarding the Northern Nevada Behavioral Health Policy Board (AB9) and Chairperson Lyons explained that providing regional oversight would be preferable to State oversight. There were no public comments; therefore, Chairperson Lyons entertained a motion.

**(1:09:17) – Member Schuette moved to accept the Director’s report as presented. Member Bagwell seconded the motion.**

<b>RESULT:</b>	<b>APPROVED (7-0-0)</b>
<b>MOVER:</b>	Member Schuette
<b>SECONDER:</b>	Member Bagwell
<b>AYES:</b>	Members Bagwell, Furlong, Jones, Schuette, White, Vice Chair Giomi, and Chair Lyons
<b>NAYS:</b>	None
<b>ABSTENTIONS:</b>	None
<b>ABSENT:</b>	None

**26.D FOR POSSIBLE ACTION: DISCUSSION AND POSSIBLE ACTION REGARDING THE SECOND BIENNIAL 2022 REPORT FROM VITALITY UNLIMITED AS REQUIRED BY CONTRACT #1718-118 BETWEEN CARSON CITY AND VITALITY UNLIMITED, WITH AN EMPHASIS ON CIVIL PROTECTIVE CUSTODY (“CPC”) ADMISSIONS.**

(1:09:31) – Chairperson Lyons introduced the item. Vitality Unlimited Clinical Supervisor Elizabeth Hawthorne reviewed the December 1, 2021, to November 30, 2022 Report, incorporated into the record. In response to a question by Chairperson Lyons, Ms. Hawthorne clarified that the higher number of patients in Elko County, reflected in the report, was due to many Carson City residents being treated in Elko because of the availability of beds and their ability to house in-patient adolescents. There were no public comments.



**CARSON CITY BOARD OF HEALTH**  
**Minutes of the December 15, 2022 Meeting**  
**Page 4**

**DRAFT**

**(1:11:42) – Vice Chair Giomi moved to accept the report as presented. Member Bagwell seconded the motion.**

<b>RESULT:</b>	<b>APPROVED (7-0-0)</b>
<b>MOVER:</b>	Vice Chair Giomi
<b>SECONDER:</b>	Member Bagwell
<b>AYES:</b>	Members Bagwell, Furlong, Jones, Schuette, White, Vice Chair Giomi, and Chair Lyons
<b>NAYS:</b>	None
<b>ABSTENTIONS:</b>	None
<b>ABSENT:</b>	None

**27. PUBLIC COMMENT**

(1:11:56) – Chairperson Lyons entertained public comments. Vice Chair Giomi thanked Member Jones “for doing a stellar job of representing not only Ward 3 but the whole community.”

**28. FOR POSSIBLE ACTION: TO ADJOURN**

(1:12:48) – Chairperson Lyons adjourned the meeting at 1:12 p.m.

The Minutes of the December 15, 2022 Carson City Board of Health meeting are so approved on this 2<sup>nd</sup> day of March, 2023.

ATTEST:

\_\_\_\_\_  
DR. COLLEEN LYONS, Chair

\_\_\_\_\_  
SCOTT HOEN, Clerk – Recorder



## STAFF REPORT

**Report To:** Board of Health

**Meeting Date:** March 2, 2023

**Staff Contact:** Nicki Aaker, Director

**Agenda Title:** For Possible Action: Discussion and possible action regarding the proposed acceptance of a report from the Carson City Health Officer. (Nicki Aaker; [NAaker@carson.org](mailto:NAaker@carson.org))

Staff Summary: This item is to provide an update on: (1) the Health Officer's activities; (2) clinical oversight and policy input; (3) training and education; and (4) general information for the Carson City Board of Health. Direction is requested from the Board of Health regarding the Health Officer's report concerning activities the Health Officer is engaged in both internally and externally for the Carson City Department of Health and Human Services.

**Agenda Action:** Formal Action / Motion

**Time Requested:** 15 minutes

### **Proposed Motion**

I move to accept the report as presented.

### **Board's Strategic Goal**

Quality of Life

### **Previous Action**

N/A

### **Background/Issues & Analysis**

A Health Officer's report is presented at each Board of Health meeting.

### **Applicable Statute, Code, Policy, Rule or Regulation**

N/A

### **Financial Information**

**Is there a fiscal impact?** No

**If yes, account name/number:**

**Is it currently budgeted?**

**Explanation of Fiscal Impact:**

### **Alternatives**

Do not accept the report and/or provide alternative direction.

**Attachments:**

[Health Officer's Report - Activities\\_V2.pdf](#)

[Health Officer's Report.pdf](#)

**Board Action Taken:**

Motion: \_\_\_\_\_

- 1) \_\_\_\_\_
- 2) \_\_\_\_\_

Aye/Nay

\_\_\_\_\_  
\_\_\_\_\_  
\_\_\_\_\_  
\_\_\_\_\_  
\_\_\_\_\_

\_\_\_\_\_  
(Vote Recorded By)



**Carson City Health Officer Report**  
Carson City Board of Health Meeting 02Mar2023

10Feb2023

**Health Officer Activities** (since 18Nov2022)

- Behavioral Health Task Force (BHTF) meetings: 1/5 re: state funding
- CCHHS Division Managers' meetings: 11/21, 12/12, 1/9
- CCHHS Division Mangers' luncheon: 1/12
- Attended CCHHS Holiday potluck: 12/21
- Nevada State Board of Health: 12/2
- Community Health Needs Assessment (CHNA) meetings: 11/23
- Quad-County Coalition meeting: 12/13, 1/10  
Reviewed all Quad-County Public Health Preparedness (PHP) emails, attachments and numerous national and state support materials
- Attended Family Life Committee (FLC) of Carson City School District in support of resuming certified curriculum in the Carson high schools by CCHHS staff: 11/28
- Nevada County Health Officers' meeting: 12/12, 1/9
- Met with CCHHS Director: 12/12, 1/12
- Attended Title X (Family Planning) funding update: 1/9
- Attended Nevada Public Health Association (NPHA) advocacy meeting: 1/20
- Average of 8 hours per month in review of CCHHS emails, CDC Covid Weekly; Tracker and Health Alert Network (HAN), Trust for America's Health, Public Health Communication Collaborative, Nevada Department of Public & Behavioral Health (DPBH) emails and technical bulletins, Nevada Hospital association weekly reports

**Clinical Oversight and Policy Input**

- Provided training to Public Health Nurses on Skills Day re: over the counter (OTC) and prescription medication use and protocols for Shelter Kit usage: 1/23

**Training and Education**

- Fit testing for N95 mask: 12/8
- Personal Protective Equipment (PPE) usage training: 1/23
- "Reaching Gen Z: Engaging young audiences in public health" – virtual: 12/12
- CDC State, Tribal, Local, and Territorial (STLT) COVID updates: 12/12
- "Exposing the profiteers behind Medicare REACH" - virtual by Physicians for a National Health Program (PNHP.org): 1/26
- Enrolled in Nevada Community Health Worker Association virtual training: Jan - Mar
- Successfully completed 2-year recertification period for American Board of Family Medicine (ABFM) board certification as of 31Dec2022

**Carson City Health & Human Services**

900 East Long Street • Carson City, Nevada 89706 • (775) 887-2190 • Hearing Impaired-Use 711

Clinical Services (775) 887-2195 Fax: (775) 887-2192	Public Health Preparedness (775) 887-2190 Fax: (775) 887-2248	Human Services (775) 887-2110 Fax: (775) 887-2539	Disease Control & Prevention (775) 887-2190 Fax: (775) 887-2248	Chronic Disease Prevention & Health Promotion (775) 887-2190 Fax: (775) 887-2248
--	---	---	---	--



## **General Information for the Carson City Board of Health from Dr. Lyons, Carson City Health Officer**

### ***Article: Public health agencies: learn from NASA about regaining the public's trust***

By Dr. Judy Monroe - September 22, 2022

The amazing images of the [Cartwheel Galaxy](#) captured by the James Webb Space Telescope this summer, and before them the [spectacular images](#) from the Hubble telescope, have amazed and inspired many people worldwide, who now look to NASA as a trusted federal agency.

It hasn't always enjoyed such strong support. After the [Challenger disaster](#), in which the space shuttle with seven crew members aboard exploded after liftoff, NASA was beset by questions about its decision-making and faced a significant challenge with public perceptions. It learned painful lessons about a flawed management structure and poor communications.

The Centers for Disease Control and Prevention and other public health agencies [find themselves in a similar position](#) these days, having [lost the trust](#) of their stakeholders during the Covid-19 pandemic.

It took partnership, resources, scientific rigor, and imagination to create and launch the Webb and Hubble telescopes to give humanity an unprecedented view of the universe. Establishing a new era in public health will take these same elements to give the public health system the funding, tools, and workforce needed to protect Americans from unprecedented health threats.

Just as it took NASA years to transform itself into one of the most trusted federal agencies, it will take time for the public health system to earn back the trust it has lost. NASA embarked on that road by [moving](#) from being a hierarchical, closed system that develops its technologies internally to an open network organization that embraces innovation, agility, and collaboration. The U.S. public health system must follow that trajectory.

In August, CDC director Rochelle Walensky [announced plans](#) to restructure and reorganize the agency. Of course, much more work must be done across the entire public health spectrum to institute long-lasting change.

Trust for America's Health recently [released a report](#) on America's public health system and concluded that "chronic underfunding has created a public health system that cannot address

the nation’s health security needs, its persistent health inequities, as well as emerging threats,” noting that this was “a contributing factor in the inadequate response to the Covid-19 pandemic.”

The [CDC Foundation](#), which I lead, in collaboration with the [Association of State and Territorial Health Officials](#), the [National Association of County and City Health Officials](#), the [Big Cities Health Coalition](#), and other public health partners, has issued a [series of reports](#) offering ways to build a resilient, well resourced, trusted public health system that helps assure everyone can attain their full potential for health and well-being. Public health needs a harmonized, strategic, and action-oriented approach to explore these opportunities.

Key tactics from these reports include:

- providing increased, multiyear, sustainable funding from all levels of government that supports the public health workforce by creating pipelines for staff and careers and establishing strategic workforce development plans that include hiring practices and salary incentive needs and enhancements;
- harnessing the power of today’s technology to collect and analyze data in a timely fashion to manage public health threats and conditions;
- recognizing that laws and [legal concepts like preemption](#) are affecting public health authority and weakening the field’s ability to address health and equity;
- creating clear communication about public health guidance to the broad population as well as more effective communication about the incredible value of public health contributions over time to the health, safety and security of us all.

Thirty-six years ago, NASA faced a crisis of trust. It took a [Presidential commission](#) before the agency launched a space shuttle nearly three years after the Challenger disaster. But unlike launching into space, which is an arbitrary goal, the next health crisis could happen at any time, whether it’s another Covid-19 variant, a new virus that has leapt from animals to humans, a worsening opioid crisis, or an increase in chronic diseases. The public health system must implement change now to protect Americans’ health and safety.

Investment in public health is paramount, but so are the underpinnings that make it work — growing the workforce, creating the legal authority to ensure the system has the tools needed to do its job, achieving health equity, updating and modernizing technology, and reimagining public-private partnerships. Americans need all sectors to come together to strengthen their public health infrastructure.

*Judy Monroe is a physician and the president and CEO of the CDC Foundation, based in Atlanta, Georgia.*

[@DrJudyMonroe](#)  
[linkedin.com/in/drjudymonroe/](https://www.linkedin.com/in/drjudymonroe/)

## Article Reference

Monroe, J. (2022, September 22). STAT – First Opinion - Public health agencies: Learn from NASA about regaining the public’s trust. {Post}. LinkedIn.

[https://cm.linkedin.com/posts/drjudymonroe\\_public-health-agencies-learn-from-nasa-about-activit y-6978818463196692480-kBxP](https://cm.linkedin.com/posts/drjudymonroe_public-health-agencies-learn-from-nasa-about-activit-y-6978818463196692480-kBxP)

---

December 8, 2022

## **Blog: <https://debeaumont.org/news/2022/new-poll-results-show-broad-public-support-for-public-health-departments/>**

By [Mark Miller](#)

Over the past few years, public health departments across the country have been navigating a changing world—in disease, staffing, funding, public perception, and more. But as the world changes, health departments continue to play a critical role in their communities. And according to a poll released today, Americans value that role.

In a [recent Morning Consult poll](#) commissioned by the de Beaumont Foundation, **90 percent of U.S. adults said they view public health departments as an essential element of a healthy community, rating health departments above schools, fire departments, police departments, parks, businesses, and libraries.** According to the data, the health department services Americans most value include reaching out to people at greatest risk for having poor health outcomes, working with the broader healthcare system, improving other local community services, and ensuring environmental health.

About half of Americans said they are familiar with their local health departments and health officials—an increase from [a similar poll](#) on public health support conducted in 2018 by Public Opinion Strategies. However, among the adults who said they are familiar with their local public health official, fewer have a favorable view than they did a year ago (67% in Morning Consult’s 2021 survey and 61% in 2022), and Americans are more likely to say the health of their community has gotten worse over the past year (26% in 2021 and 32% in 2022).

**deBeaumont Foundation** is a trusted public health stakeholder

Mission – To advance policy, build partnerships, and strengthen public health to create communities where people can achieve their best possible health

Vision – A nation where every person in every community has the opportunity to achieve their best possible health.

---

# CDC COVID-19 Data Review: Update on COVID-19–Related Mortality

Updated Nov. 16, 2022

## Top Takeaway Messages:

1. There were signs of improvement –
  - COVID-19–related deaths substantially decreased in the United States in March 2022. During April–early November 2022, this initial decline was largely sustained and the overall number of COVID-19–related deaths remained relatively stable.
  - From January to April 2022, age-standardized COVID-19–related mortality rates decreased for all racial and ethnic groups.
  - The risk of in-hospital deaths for patients hospitalized with COVID-19 declined among all adult age groups. During March–August 2022, risk of in-hospital death was lower than during June 2021 – February 2022.
  - Use of outpatient COVID-19 treatments that decrease risk for hospitalization and death increased from January - July 2022.
2. Vaccines continued to be effective in reducing COVID-19–related mortality  
COVID-19 vaccines continued to reduce the risk of dying among all age groups, including older adults, with the most protection observed among people who have received  $\geq 2$  booster doses.
3. Where and how COVID-19–related deaths occur appeared to be changing
  - Although the highest proportion of COVID-19–related deaths occurred in hospitals during January–September 2022, an increased proportion of COVID-19–related deaths were reported in other settings such as homes, long-term care facilities and hospice facilities than in prior years of the pandemic.
  - COVID-19 was listed as the underlying cause for most COVID-19–related deaths. However, during January–September 2022, COVID-19 was identified as a contributing cause of death rather than the underlying cause for a higher proportion of COVID-19–related deaths than in prior years of the pandemic.
4. Improvement is needed to decrease risk for COVID-19–related mortality
  - During April–September 2022, 2,000–4,500 COVID-19–related deaths were reported weekly and, a higher number of all-cause deaths occurred in the United States compared to what was expected based on previous years of data ([excess deaths](#)).
  - Adults aged  $\geq 65$  years continued to have the highest COVID-19–related mortality rates. Adults aged  $\geq 85$  years remained at particularly high risk of dying, with the proportion of COVID-19–related deaths accounted for by adults in this age group increasing during April–September 2022 from  $\sim 28\%$  to  $\sim 40\%$  of COVID-19–related deaths.



- Older adults, people with disabilities, and those with underlying medical conditions continued to account for the highest proportion of COVID-19–related in-hospital deaths.
- COVID-19–related deaths were rare among younger adults aged 18–49 years hospitalized during May–August 2022, but those that did occur were most often among unvaccinated persons.

---

## **NIHCM (National Institute for Health Care Management) NEWSLETTER - December 2022**

### **Long COVID & Disability**

Long COVID has **affected as many as 23 million Americans** since the beginning of the pandemic. Experts have referred to long COVID as ‘the next public health disaster’ and estimate the financial toll may have a \$3.7 trillion impact on the US economy. Last year, the **Department of Health and Human Services (HHS)** declared long COVID could be classified as a disability under federal law. However, there are gaps between **protections and accommodations** in the workplace and **barriers to disability benefits** for people with long COVID. Despite longstanding federal civil rights laws, disabled people **experience disparities** in health and health care.

**As many as 4 million people are out of work due to long COVID in the US.** Many have been **denied disability coverage** because they don’t have documentation from specialist physicians. Long-haulers’ disabilities range from fatigue to body-wracking tremors. Some are turning to **costly, unproven treatments** for relief.

Comment: Disparities persisted. Although racial and ethnic disparities in COVID-19–related mortality have decreased over the course of the pandemic, disparities continued to exist in both COVID-19 treatment and mortality.

---

**Measles outbreak** in Columbus, Ohio. As of 12/21, 36% of the identified measles cases were hospitalized, with zero fatalities. Unvaccinated individuals represented 94% of the cases.

---

### **Nevada Hospital Association report excerpts:**

On Jan. 11, 2023, HHS renewed the national **Public Health Emergency (PHE)** for COVID-19. The PHE is anticipated to be allowed to expire in April.

The US has seen 39 **mass shootings** in the first 24 days of the year. Seventy people (70) people have been killed and 167 wounded in mass shootings so far in 2023.

A Health Economics study (published Jan.19) found that when **recreational cannabis** is legal, codeine demand drops. Key findings included a 26% reduction in the pharmacy-based distribution of codeine and as much as a 37% reduction after recreational cannabis laws have been in effect for four years.

US FDA added (Jan. 1, 2023) **sesame** to the list of major food allergens defined by law. Now many food processing companies are being accused of adding sesame to foods in limited quantities to avoid the strict rules associated with keeping the seed isolated from other foods and equipment. Adding sesame to all foods processed at a particular plant and changing packaging labels is cheaper than modifying production lines. This reportedly is also becoming the practice at many chain restaurants.

A new report from the RAND Corporation finds that 25.8% of US armed forces personnel, including 15.4% of active- duty military, are **food insecure** (defined as not having access to sufficient food or adequate quality food to meet one's basic needs).

Governor Joe Lombardo has signed Executive Order 2023-004 directing all occupational boards to provide a recommended pathway for facilitating **licensure reciprocity**. Boards shall report back before April 1, 2023.

### **Cyber News:**

Thirty-seven million T-Mobile customers had their personal information, including names, addresses, email, phone numbers, date of birth, and account numbers, stolen by hackers who exploited an API (application programming interface) used by the carrier.

LastPass, a virtual password vault, was reportedly hacked multiple times in the past few months. Now the company is facing litigation to disclose specifically all the types of private information that was compromised as clients assert their passwords entrusted to LastPass have been used to steal Bitcoin and access other financial accounts and medical records.

FEMA released the 2022 National Preparedness Report. According to the report, **cyber threats are the number one threat/hazard type likely to occur**.

The US Securities and Exchange Commission is expected to require companies to disclose details about cybersecurity and attacks, including specifying which board members have cybersecurity expertise. The rules are anticipated to focus on increasing board responsibilities.



## STAFF REPORT

**Report To:** Board of Health **Meeting Date:** March 2, 2023

**Staff Contact:** Nicki Aaker, Director

**Agenda Title:** For Possible Action: Discussion and possible action regarding a proposed acceptance of the report of the Carson City Department of Health and Human Services ("CCHHS") Director, Nicki Aaker. (Nicki Aaker, [naaker@carson.org](mailto:naaker@carson.org))

Staff Summary: The CCHHS Director's report will concern: (1) an update on Title X funding; (2) an overview of CCHHS workforce challenges; (3) an update on relevant bills proposed during the 2023 Nevada legislative session; (4) an introduction of the Community Management Information System to be used for Carson City's Street Outreach program; and (4) requests for assistance for: (a) Title X funding, (b) workforce challenges, (c) continued support for Assembly Bill No. 118, (d) continued support for Carson City's Housing Plan, and (e) the Community Health Improvement Fund.

**Agenda Action:** Formal Action / Motion **Time Requested:** 20 minutes

### Proposed Motion

I move to accept the Director's report.

### Board's Strategic Goal

Quality of Life

### Previous Action

August 18, 2022 (Item 22D): Carson City's Housing Plan was approved by the Board of Health.

### Background/Issues & Analysis

A report of the CCHHS Director is presented at each Board of Health meeting.

### Applicable Statute, Code, Policy, Rule or Regulation

N/A

### Financial Information

**Is there a fiscal impact?** No

**If yes, account name/number:**

**Is it currently budgeted?**

**Explanation of Fiscal Impact:**

### Alternatives

Do not accept the report and/or provide alternative direction.

**Attachments:**

[CCHHS – Director’s Report Presentation.pdf](#)

[Director's Report V3\\_NP edits.pdf](#)

**Board Action Taken:**

Motion: \_\_\_\_\_ 1) \_\_\_\_\_  
2) \_\_\_\_\_

Aye/Nay

\_\_\_\_\_  
\_\_\_\_\_  
\_\_\_\_\_  
\_\_\_\_\_  
\_\_\_\_\_

\_\_\_\_\_  
(Vote Recorded By)



# CCHHS – DIRECTOR’S REPORT

Nicki Aaker, Director; Carson City Health and Human Services

Carson City Board of Health

March 2, 2023



1

## HIGHLIGHTS & REQUESTS FOR BOARD OF HEALTH

- ✓ Access to Care - Title X (Family Planning) funding ends March 31, 2023 which is a loss of nearly \$300,000/year. A grant from Nevada’s Department of Health and Human Services will be coming to the Board of Supervisors to assist with the elimination of funding.
  - ASK – Continue to advocate for Title X funding for northern Nevada at the federal level and accept the Reproductive Grant from the State of Nevada.
- ✓ Workforce Challenges – CCHHS has three (3) very hard to fill positions vacant: 1) Public Health Nurse, 2) Epidemiologist, and 3) Public Health Preparedness Division Manager.
  - ASK – Reach out to your constituents and contacts to let them know we have these job opportunities. Please have them apply at [carson.org](http://carson.org).
- ✓ Legislative Session - Public Health Funding - SB118 is a public health funding bill. It passed out of the Senate Health and Human Services Committee with a ‘Do Pass’. The funding suggested in this bill is non-categorical which can be used for unfunded, urgent, emergency public health efforts, or priorities identified in the Community Health Needs Assessment.
  - ASK – Continue to support for SB118.

2

## HIGHLIGHTS & REQUESTS FOR BOARD OF HEALTH

- ✓ Homelessness – Our community does not have a lot of data surrounding homeless. The Community Management Information System (CMIS) used throughout the state is releasing a module that can be used for Carson City’s street outreach program.
  - ASK - Continue to support the Carson City Housing Plan especially as we work to get a contractor for street outreach.
- ✓ Community Health Improvement Plan (“CHIP”) – Having completed the Community Health Needs Assessment (CHNA), the next step is to convene a diverse and engaged stakeholder group to review the data and findings. As a collaborative group, a plan of action known as the CHIP will be developed to address these matters for improvement in our community.
  - ASK – Board of Health members assist in identifying and recruiting stakeholders to participate in this collaborative group (i.e., school district, hospital, community behavioral health clinics). Refer them to Nicki Aaker at [naaker@carson.org](mailto:naaker@carson.org) with CHIP in the subject line.

3

## HIGHLIGHTS BOARD OF HEALTH

- ✓ COVID-19 Response After Action Report (“AAR”) – A contractor was hired to conduct an AAR to review CCHHS’ response efforts. The report has been provided and CCHHS staff will work on improvements that can be addressed within the department. This fulfills one of CCHHS’ Strategic Plan goals.
- ✓ Within the Human Services Division, the Nevada Housing Division conducted a program and fiscal review of four housing programs and did not have any findings or concerns.

4

# QUESTIONS



This Photo by Unknown Author is licensed under [CC BY-SA-NC](#)



Carson City Health and Human Services Report  
 Carson City Board of Health Meeting  
 March 2, 2023

County Health Officer Name	Dr. Colleen Lyons
County	Carson City: some services provided in Douglas, Lyon, and Storey Counties

Report Highlights and Requests

- ✓ Access to Care - The Title X (Family Planning) funding ends March 31, 2023. This is a loss of nearly \$300,000/year. This grant has been received directly from the federal government since approximately 2010, and prior to that it was a subgrant from the State of Nevada. Nevada’s Department of Health and Human Services has approved through the State of Nevada’s Internal Finance Committee ARPA funding to continue the services that were unfunded. This grant, Comprehensive Reproductive Grant, will be coming forward to the Board of Supervisors once the Notice of Award is received.
  - Request to Board of Health (“BOH”) – Continue to advocate for Title X funding for northern Nevada at the federal level and accept the Comprehensive Reproductive Grant from the State of Nevada.
  
- ✓ Workforce Challenges – Within the past week, we were able to hire four (4) hard to fill positions: 1) Human Services Division Social Worker, 2) part-time front desk Office Specialist, 3) part-time Women, Infant, and Child (WIC) Specialist, and 4) a part-time Community Health Worker (CHW) to work for both the Adolescent Health and Preventive Health and Health Services programs. We still have three very hard to fill positions: 1) Public Health Nurse, 2) Epidemiologist, and 3) Public Health Preparedness Division Manager.
  - Request to BOH – Reach out to your constituents and contacts to let them know we have these job opportunities. Please have them apply at [carson.org](http://carson.org).



- ✓ Public Health Funding - Legislative session has started. There is one public health funding bill, SB118. This bill was introduced on February 16, 2023, in the Senate Health and Human Services Committee and received a 'Do Pass'. In the 2019 Legislative Session, the Public Health Improvement Fund was created; however, it was not in the Governor's budget so was unfunded. Public health funding has been a focus of the Interim and Legislative sessions for six years. The funding suggested in this bill is non-categorical. This type of funding can be used for unfunded, urgent, emergency public health efforts, or priorities identified in the Community Health Needs Assessment. Nevada is tied with Wisconsin for last in state public health funding at \$72/person, the median is \$119/person. This bill is proposing \$5 per person per year be spent on public health. The return on investment for every \$1 spent on public health is \$5.60.
  - Request to BOH - Continue to support for SB118.
  
- ✓ Homelessness – Our community does not have a lot of data surrounding homeless. Every year the Point in Time Count is conducted in January. Professionals working with the homeless know the number counted during this event is much lower than the true homeless population. The Community Management Information System (CMIS) used throughout the state is releasing a module that can be used for a Carson City street outreach program. This information will assist in mapping homeless encampments and identify who is in the camps. This program will be able to follow individuals from camps to permanent housing (see page 14 for example).
  - Request to BOH - Continue to support the Carson City Housing Plan especially as we work to get a contractor for street outreach.
  
- ✓ Community Health Improvement Plan (“CHIP”) – Having completed the Community Health Needs Assessment (CHNA), the next step is to convene a diverse and engaged stakeholder group to review the data and findings. Existing and new partners will need to be identified, along with the resources available to work on the priority areas, as well as identify gaps or overlap in resources and services. As a collaborative group, a plan of action known as the CHIP will be developed to address these matters for improvement in our community.
  - Request to BOH – Board of Health members assist in identifying and recruiting stakeholders to participate in this collaborative group (i.e., school district, hospital, community behavioral health clinics). Refer them to Nicki Aaker at [naaker@carson.org](mailto:naaker@carson.org) with CHIP in the subject line.
  
- ✓ COVID-19 Response After Action Report (“AAR”) – A contractor was hired to conduct an AAR to review CCHHS' response efforts. The process involved surveys, conference calls, and individual calls to several of our partners and employees. CCHHS staff will work on improvements that were identified and can be addressed within the department. This fulfills one of CCHHS' Strategic Plan goals. Within the Human Services Division, the

Nevada Housing Division conducted a program and fiscal review of four housing programs and did not have any findings or concerns.

## Division Reports

### Clinical Services

- The Clinical Services Division Manager, Katharyn Reece, is working with a new third-party billing company to bring them on board to bill for the CCHHS Clinic and the flu Point of Distribution (POD) events. This spring the goal is to review revenue cycles for optimization.
- Staff is preparing for the Title X (Family Planning) funding to end March 31, 2023. CCHHS has received this grant for upwards of thirteen years.
- Thank you to the State of Nevada, Department of Health and Human Services for working on a solution for the loss of the Title X (Family Planning) grant in northern Nevada. This solution goes through December 2026. As of April 1, 2023, CCHHS will no longer receive the designation of a Title X Clinic and there will be no Title X protections (i.e., teen confidentiality).
- Drs. Timothy McFarren and Sandra Koch continue to advocate for the clinic funding at the state and federal level.

Family Planning (Title X) Unduplicated Clients / Number of Visits		
2020 Total	2021 Total	2022 Total
1682/3016	1627/2846	2096/2544

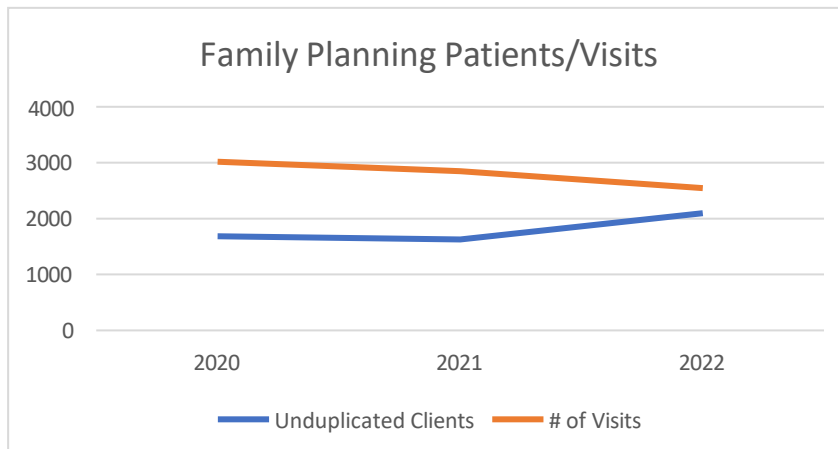

This chart tells us that more patients are coming to CCHHS for services while the number of visits is decreasing. This may be due to CCHHS having an Advanced Practice Registered Nurse (APRN) that can insert long lasting birth control implants which result in less visits to the clinic.

Vaccinations Administered / Number of Individuals		
2020	2021	2022
5,313 / 2,486	4,034/1,762	4,360/2,353

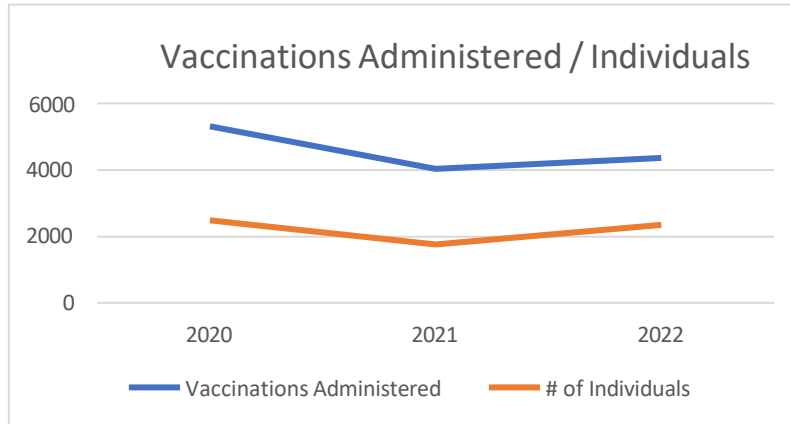

#### Carson City Employment Drug Screening

CCHHS is the department that administers the City’s drug screening for new employees.

Carson City Pre-employment Drug Screens		
2020	2021	2022
161	206	194

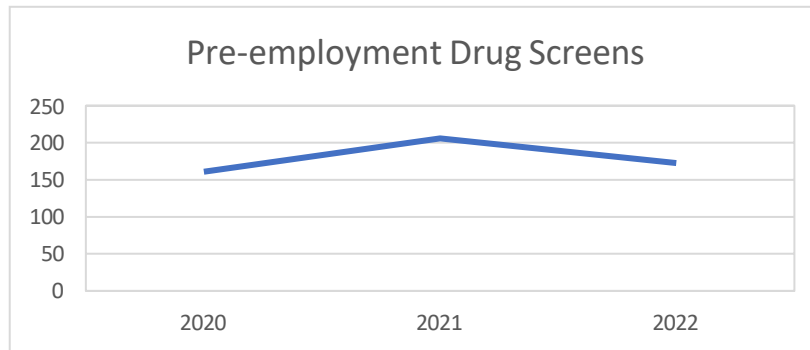

#### Tuberculosis (TB) Screening

A TB test is a two-visit process. One visit to place the test and the second visit to assess the results. Some individuals are required to have two tests within 7 to 21 days of each other which requires 4 visits to complete both rounds of screening. TB testing includes services provided both at the clinic and an inpatient drug treatment center (Vitality).

Tuberculosis (TB) Screening / Number of Individuals		
2020	2021	2022
565/418	629/467	534/397

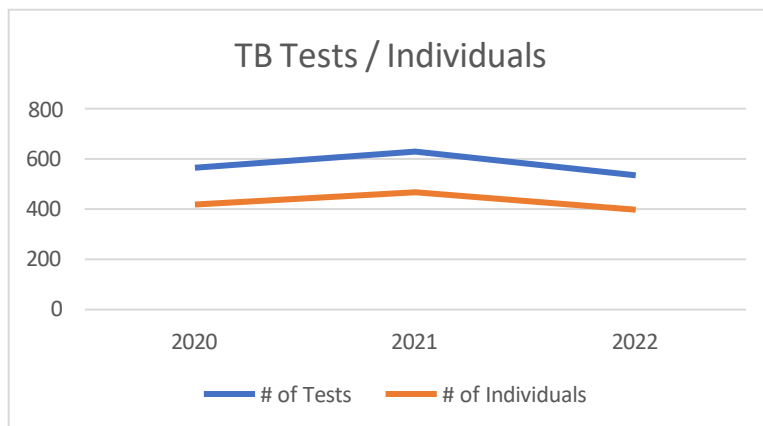

#### Budget

- General Funds – 11%
- Grants – 57%
- Revenue – 32%

#### Staff Training

- Supervisor Training for Manager
- Safety Considerations for Vaccine-related Events
- Nevada Consent Laws

#### Challenges

- Hiring a Bilingual Public Health Nurse has been a significant challenge with the position open for over 6 months. Staff shortages in general have created a challenge for availability to serve clients with same-day, next-day appointments as well. Posting has been changed to a Public Health Nurse deleting the bilingual requirement. If needed a translation service will be used.



#### Chronic Disease Prevention and Health Promotion (CDPHP)

##### Adolescent Health Education Program

##### Outreach Events

- Outreach continues to non-traditional partners with the goal of having more education programs.

- During COVID-19 and to the present, the program was not allowed back into the high school. Roni Galas has worked very hard with the Carson City School District’s Family Life Committee to get back into the high school so classes can be conducted. CCHHS has received word that the program will be allowed back in the high school, but dates for classes have not been scheduled.

### Challenges

Recruitment of organizations other than schools to host classes continues.

### Ryan White – Retention in Care Program

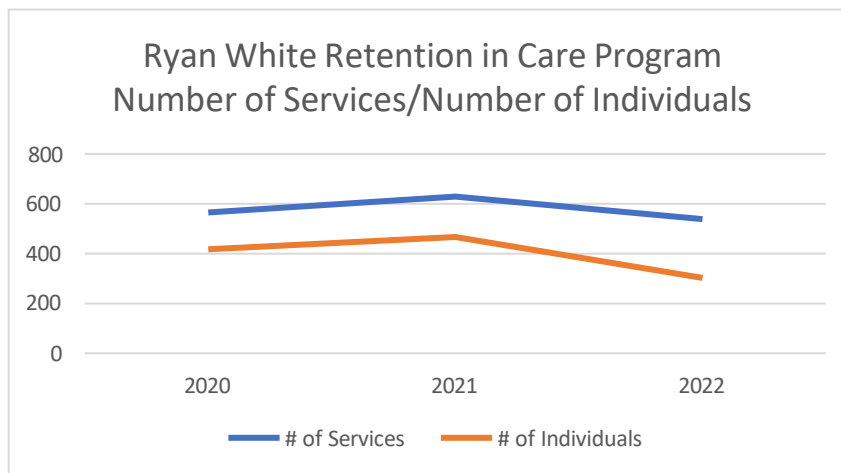

\* Number of individuals and services declined in 2022 because state reports used to identify individuals that are out of medical care were not being received on a regular basis.

### Tobacco Control and Prevention Program

Funding comes from four separate sources: 1) CDC Tobacco Prevention, 2) Health Disparities Grant through the Nevada Cancer Coalition, 3) Nevada Clinical Services formerly the Funds for Healthy Nevada, and 4) Nevada’s Youth Vaping Prevention Funds.

- Staff continue to participate in Nevada Tobacco Prevention Coalition as members, which will be important during the 2023 Legislative session. This coalition continues to work on policies related to addressing Youth Access via Tobacco Retailers, the Nevada Clean Indoor Air Act, and Tobacco Prevention and Control Funding.
- Suzie Ledezma-Rubio, Program Coordinator, continues to be a member of Western Nevada College’s (WNC) Healthy Campus Environment Committee.
  - In 2017, CCHHS staff assisted WNC in becoming a tobacco free campus.
  - Staff continue to assist WNC with strengthening their Tobacco Free Policy and supplying signage.
- Staff are updating the multi-unit housing (“MUH”) list to identify locations that have smoke-free policies.
  - A script and survey are being developed to gather information on known and unknown policies, along with promoting the adoption of smoke-free policies to those complexes without policies and signage for any complex that wants it.

- A toolkit has been developed by staff for owners and property managers on how to implement a voluntary smoke-free policy.
- The most recent location to adopt a smoke-free policy is “Carson Hills “as of 01/01/22.

#### Outreach Events

- Staff are continuing to collaborate with local coalitions, Southern Nevada Health District, and Washoe County Health District to develop an initiative known as Attracting Addiction.
  - The goal is to educate parents and adult influencers on the predatory practices of the tobacco industry, increase awareness of the dangers of smoking and vaping flavored tobacco products, prevent youth and adults from becoming tobacco users, and support the elimination of all flavored tobacco products.
  - Social media posts have been created by an outside contractor that provides education to parents and youth.
  - Education materials have been distributed to parent groups and at outreach events.

#### Challenges for Chronic Disease Prevention and Health Promotion

- Youth Vaping Funds are in jeopardy.
- Getting back into all the schools to conduct classes at pre-COVID-19 levels. (Adolescent Health Education and Tobacco Control and Prevention)
- Finding youth to conduct focus groups and youth engagement in general. (Tobacco Control and Prevention)

#### Budget

- General Funds – None
- Grants – 100%



Permitted Establishments – Inspections Conducted				
Permitted Establishments	2019	2020	2021	2022
Restaurants Carson City	670	608	700	685
Restaurants Douglas County	772	726	827	686
Temporary Events Carson City	169	0	131	240
Temporary Events Douglas County	78	2	169	369
Childcare Facilities	20	18	24	26
Public Pools, spas, aquatics Carson City	49	50	66	65
Public Pools, spas, aquatics Douglas County	94	79	100	56
Septic	9	5	10	10
Hotels/Motels	24	4	42	29
Schools	15	16	24	23

Permitted Establishments – Violations, Carson City Only				
Permitted Establishments	2019	2020	2021	2022
<b>Food</b>				
Critical	71	195	175	215
Non-critical	243	439	385	481
<b>Pools</b>				
Critical	4	17	12	8
Non-critical	4	25	148	67

Plans Reviewed				
	2019	2020	2021	2022
Number of Plans	*	*	156	242

\*Plan review system changed in 2021

Mosquito Abatement				
	2019	2020	2021	2022
Number of Hours by EH Staff	32	30	55	28

Other News

- Two foggers were donated to Carson City by Douglas County’s Mosquito Abatement program.
- A \$25,000 grant was awarded to CCHHS to work towards Environmental Health Inspection Standardization.

Staff Trainings

- Soil and Site Evaluation for Onsite Wastewater Systems

Epidemiology

NOTE: Health authority investigation of reportable communicable diseases is required by NRS 441A.

Respiratory illness season beginning Morbidity and Mortality Weekly Report (“MMWR”) week 40 (first week of October) had a large impact on the health care system in Nevada. In our surveillance area, more hospitalizations were reported in MMWR weeks 40-52 (October to December) for Influenza, which was 78, then were reported for all of last Influenza season, which was 58. RSV (Respiratory Syncytal Virus) reports increased by 62% for MMWR weeks 40-52 compared to the same reporting period in 2021.

In December 2022, the Carson City Board of Supervisors approved several grant funded City positions. This allows for the Epidemiology Division to “Right Size” as we transition to the post COVID emergency.

In September, our Statewide disease surveillance system was transitioned to a more modern system. Since it is a new system, we are in the process of learning the system and fine tuning our reporting.



Sexual Health Statistics (Carson City)				
	2019	2020	2021	2022
Chlamydia	265	188	206	227
Gonorrhea	42	43	52	34
Primary and Secondary Syphilis	8	6	10	10

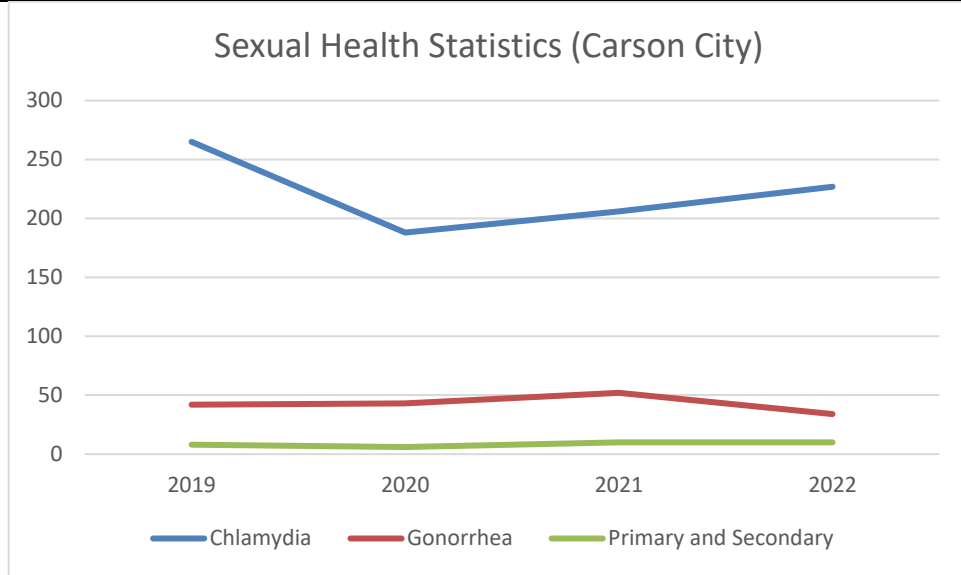

Sexual Health Statistics (Douglas & Lyon Counties)				
	2019	2020	2021	2022*
Chlamydia	287	256	282	199
Gonorrhea	52	93	65	46
Primary and Secondary Syphilis	5	7	15	7

2022 statistics are likely due to decrease in testing, not a decrease in cases.

\*Due to the reporting system change, the numbers of reported conditions should be considered preliminary and are subject to change.

Vector Borne Diseases (i.e., West Nile, etc.)				
	2019	2020	2021	2022
Carson City	0	0	0	0
Douglas & Lyon Counties	0	0	1	0

Other Disease Investigations – Carson City, Douglas, and Lyon Counties				
	2019	2020	2021	2022
Campylobacteriosis**	6	0	10	17*
GI Outbreak (Childcare Facility)	0	0	1	0
Rabies, Animal (Bat)	0	0	1	1
RSV Outbreak (Childcare Facility)	0	0	2	2
Salmonellosis+	4	3	9	12*

\*Due to the reporting system change, the numbers of reported conditions should be considered preliminary and are subject to change.

\*\* Common causes of foodborne illness

Influenza Hospitalizations - Carson City, Douglas, and Lyon Counties				
	2019	2020	2021	2022
Influenza Hospitalizations	36	2	6	148

#### Staff Training

- All staff were part of EpiTrax training, our new Statewide disease surveillance system.
- One staff attended the Childhood Lead Prevention conference (Virtual).

#### Budget

- General Funds – None
- Grants – 100%

#### Challenges

Right sizing the Epidemiology Division was the first step in developing a sustainable model for responding to reportable conditions and outbreaks within our surveillance area. The next step is to establish stable long-term funding of core public health services.



#### Human Services

##### Activities

- Attended Clarity Connect Conference; two major takeaways:
  - 1) The Community Management Information System (CMIS) will release a module to utilize for the Street Outreach program. The module will be able to map homeless encampments and identify who is in the encampments. When outreach is conducted the module will follow individuals from camp to permanent housing (reported as a highlight).

- A report can be run from CMIS that will show the homeless individuals assessed, and what type of housing is needed to house each individual. This report breaks it down into veterans and seniors as well.

Sample of Module:

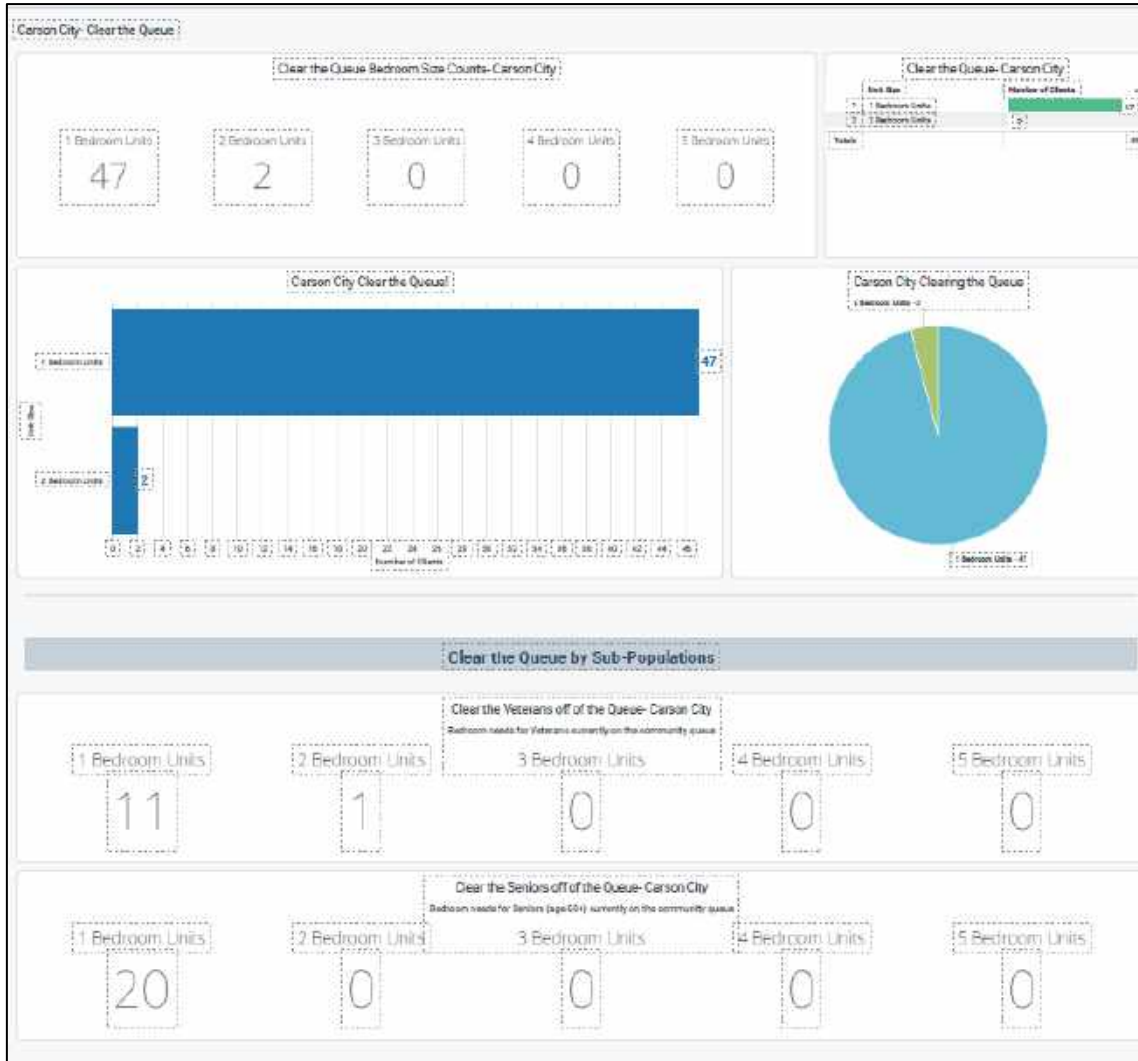

### Individuals Assisted

As of February 15, 2023:

- Point in Time Count preliminary number for count completed on January 26, 2023, is **68 unsheltered homeless**. There was not a motel count conducted this year.
- An on-going housing program, Shelter Plus Care, is assisting **7 households** that were previously chronically homeless individuals.
- Homeless prevention programs through the Emergency Solutions Grant-Homeless Prevention and Affordable Housing Tax Fund assisted **19 households**.
- The Emergency Solutions - Rapid Rehousing Grant made it possible to rehouse **two households**.
- Eight households** were assisted with security deposits through the Welfare Set-Aside funds.

### Individuals Assisted, continued

- **Three households** received one-time rental assistance through the Welfare Set-Aside funds.
- **Six individuals** were housed in the CSHARES Program, which is the housing partnership between Human Services and the Carson City Specialty Courts.
- **One senior** gets a rent supplement funded through the Indigent Accident Funds (IAF). He has now relocated and no longer needs rental assistance.
- With the Emergency Solutions COVID-19 Grant, **4 households** impacted by COVID-19 were assisted with rental assistance to prevent homelessness.
- **Four residents** were housed in a location secured by CCHHS who did not have a place to isolate or quarantine due to COVID-19 or were at high risk due to medical needs.
- In FY23, **1 individual** in the county receives assistance for long term care.
- There are **134 individuals** (average) in the Medicaid County Match program (long term care) in FY22.

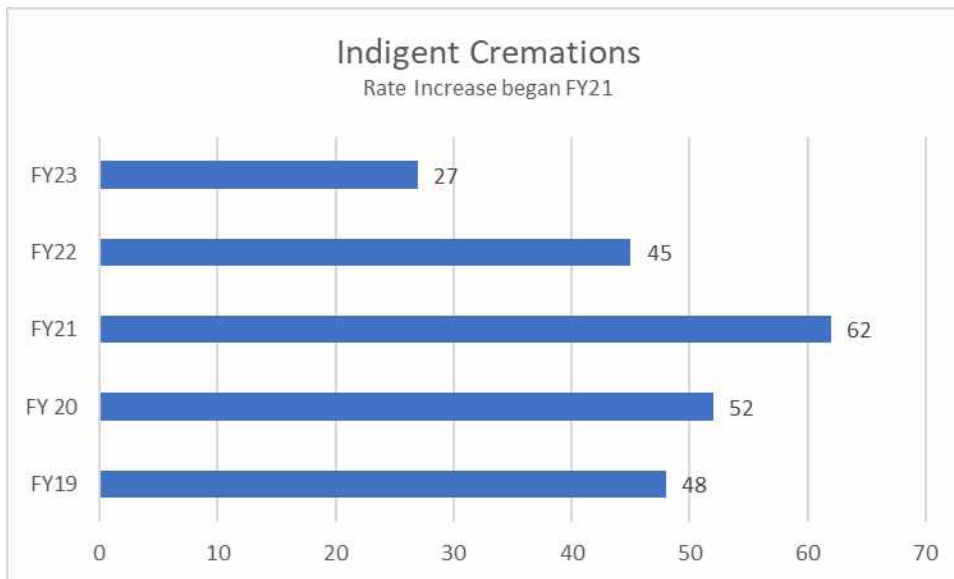

### Women, Infants, and Children (WIC)

For calendar year 2022:

- The Carson City Clinic has seen a total of **580 unduplicated participants**: 10% pregnant women, 5% fully breastfeeding, 3% partially breastfeeding, 10% not breastfeeding, 30% infants, and 43% children.
- The Gardnerville Clinic has seen a total of **294 unduplicated participants**: 12% pregnant women, 8% fully breastfeeding, 3% partially breastfeeding, 6% not breastfeeding, 33% infants, and 38% children.

### Carson City Behavioral Health Task Force Update

A Community Health Needs Assessment presentation was given. Behavioral Health continues to be a priority. This group of professionals will be part of the group working on the Community Health Improvement Plan.

## Staff Training

National Community Action Partnership (NCAP) related to Community Services Block Grant (CSGB)

## Budget

- General Funds – 29%
  - Grants – 71%\*
- \*Includes the Indigent Accident Funds

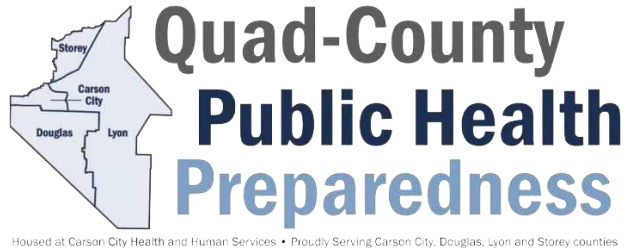

## Public Health Preparedness

### Emergency & Disaster Preparation

- Quad-County Public Health Preparedness (PHP) staff are leading Carson City departments in the development of a Mass Care and Sheltering plan for Carson City. This planning process brings together City leadership, Emergency Management, Public Works, Parks, Health, Human Services, Humane Society, American Red Cross, and volunteer groups such as CERT.
- Quad-County PHP staff are revamping the Western NV Medical Reserve Corps operational capabilities. This includes building situation-specific trainings for volunteers to include mass care sheltering and points of dispensing (POD) activities. This is being funded by a Medical Reserve Corps RISE award through NACCHO. Project completion date is June 2023.
- Several PHP staff members participated in the State Threat and Hazard Identification and Risk Assessment (THIRA) workshops in October. These workshops bring partners together who would be responsible for responding in an emergency to discuss the threats and risks to being able to accomplish responses effectively. Since every emergency has a public health component, it is important for staff to be engaged in this week-long event.
- The CCHHS COVID After-Action Report and Improvement Plan has been finalized and presented to stakeholders.

### Health Care Emergency & Disaster Preparation

- Quad-County PHP staff and a member of the Quad-County Healthcare Coalition attended the National Healthcare Coalition conference in Anaheim, CA. The conference provided the opportunity to engage with federal project officers and healthcare coalition leadership from across the country to share best practices.
- The Quad-County Healthcare Ready and Response Coordinators are keeping the Coalition apprised of the surge in respiratory illnesses including COVID-19, flu, and RSV. Staff have shared information regarding clinical staff calls with the federal government, ordering processes, and symptomology. Additionally, the coordinators are sharing resource requesting information with healthcare providers regarding antivirals.
- Quad-County PHP staff supported healthcare partners during the winter weather event around New Year's Eve with details regarding oxygen, oxygen concentrators, and warming shelter locations.

### Community Vaccinations

- Hosted 45 flu vaccination clinics administering 2,232 flu vaccines; mostly held in schools and administered to children. Total flu vaccinations administered by CCHHS in 2022 is about 10% lower than in 2021.

- October 1 – December 31, 2022: Hosted 12 COVID bivalent booster vaccination clinics administering 447 COVID-19 booster vaccines.

#### Staff Training

- One staff member helped facilitate a Northern NV Drought Workshop with Washoe County Health District and State Public Health Preparedness Division.
- Staff attended Region 9 training in California regarding the revisions to the Strategic National Stockpile.

#### Staffing Challenges

- As COVID-19 response decreases, staff are leaving to pursue other work that does not involve COVID-19.
- The search for a new Public Health Preparedness Manager began in September 2022 and continues as the search has been unsuccessful to date.

#### Budget

- General Funds – None
- Grants – 100%
- Revenue – Collected from health insurance companies and individuals for influenza vaccinations. (Community Vaccination Revenue)

## CCHHS Administrative/Fiscal

#### Staff Report

- Employees – Number of employees - 55
  - 37 FT City Employees - 67%
  - 11 PT City Employees – 20%
  - 7 Contract Employees [Marathon, Nevada System of Higher Education (NSHE)] – 13%
  - 4 Vacant Positions
  - 3 – Contracted (1) Health Officer, 2) Family Planning Medical Director, and 3) Pharmacist (not included in the percentages)

#### Challenges

- Hard to fill vacancies: 1) Fiscal/Grant Analyst – Health (will be posted again), 2) Public Health Nurse, 3) Epidemiology, and 4) Public Health Preparedness Division Manager

#### Budget

- General Funds – 100%
  - \* Three of the fiscal staff (1 FT and 2 PT) are partially grant funded and are included within the appropriate division statistics.



## Accreditation

- Additional documents or explanations requested submitted 6/23/22. To date, there has been no further news from the Public Health Accreditation Board.
- Next Steps -
  - Review of documentation by the site reviewers
  - Request for more documentation or explanations
  - Virtual site visit
  - Public Health Accreditation Board Decision

## 3<sup>rd</sup> Community Health Needs Assessment (CHNA) Update

- Executive Summary and entire assessment are located on [www.carson.org](http://www.carson.org),

## 3<sup>rd</sup> Community Health Improvement Plan

Next step is development of this plan with the help of a collaborative group of professionals and residents.





## STAFF REPORT

**Report To:** Board of Health **Meeting Date:** March 2, 2023

**Staff Contact:** Jeanne Freeman, Deputy Director

**Agenda Title:** For Possible Action: Discussion and possible action regarding the third Community Health Needs Assessment ("CHNA") of the Carson City Department of Health and Human Services ("CCHHS") and a process by which to convene a stakeholder group to review the CHNA data and findings for the purpose of creating a Community Health Improvement Plan ("CHIP"). (Jeanne Freeman, [jmfreeman@carson.org](mailto:jmfreeman@carson.org))

Staff Summary: CCHHS is required to complete a CHNA, a CHIP and a Strategic Plan on a regular schedule as part of its Public Health reaccreditation process. CCHHS formed a team with other community partners who are also required to complete or participate in the CHNA. Once the CHNA is complete, the next step is to bring this collaborative group together, further expanding the diversity of the group, and complete the CHIP.

**Agenda Action:** Formal Action / Motion **Time Requested:** 25 minutes

### Proposed Motion

I move to accept the Community Health Needs Assessment as presented [with additional direction to staff, if any].

### Board's Strategic Goal

Quality of Life

### Previous Action

June 1, 2017 (Item 20B): The Board provided feedback and direction to staff on the second CHNA.

June 21, 2012 (Item 25D): The Board accepted the first CHNA.

### Background/Issues & Analysis

Between August and December 2022, Carson Tahoe Hospital ("CTH"), CCHHS and more than twenty other local and regional partners formed a CHNA team lead by a contractor secured by CTH, to complete the latest CHNA. CTH and CCHHS were the co-lead agencies.

The CHNA team was comprised of individuals with a wide range of expertise and diverse backgrounds including non-profits, for profits, healthcare, social services, government and non-government entities. The team also included advocates for the homeless, the elderly, members of the LGBTQI community and the Tribes.

Data was collected from Carson City and Douglas, Lyon and Storey counties and was aggregated and analyzed at the regional level and also for each individual county. The multi-month data collection process included secondary data collection, more than 1,500 community surveys provided in both English and Spanish, 400 telephone surveys, more than 40 stakeholder interviews, 15 focus groups with 125 participants and an access audit. The process and results were robust. Four high-priority needs were identified: Access to Basic Needs; Mental and Emotional Health; Access to Healthcare for Specific Populations; and Substance Use, Prevention, Treatment and Recovery.

At the Carson City level, the top concerns included: access to safe, affordable housing; counseling services for mental health issues for adults; affordable prescription drugs; affordable quality childcare; counseling services for mental health issues for adolescents and children; livable wage job opportunities; and programs to help drug and other substance use disorder patients in recovery stay healthy.

To address these concerns and high priority needs, as an agency, CCHHS is a dynamic resource in the Carson City community either providing direct services or being the agency that connects community members to other resources.

The next step is to convene a diverse and engaged stakeholder group to review the CHNA data and findings to create a CHIP. This plan will identify partners and resources that are already in place to address these high-priority areas, identify gaps or overlap in the resources and services available, as well as to outline a plan of action on how all stakeholders, as a collaborative group, can work to address these matters for improvement in our community.

**Applicable Statute, Code, Policy, Rule or Regulation**

Public Health Accreditation Domain 1

**Financial Information**

**Is there a fiscal impact?** No

**If yes, account name/number:**

**Is it currently budgeted?**

**Explanation of Fiscal Impact:**

**Alternatives**

Do not accept the Community Health Needs Assessment and/or provide alternative direction to staff.

**Attachments:**

[Presentation\\_Community Health Needs Assessment BOH 3.3.2023\\_V2.pdf](#)

[Quad County Regional 2022 CHNA Executive Summary Final.pdf](#)

[Quad County Regional 2022 CHNA Final Report.pdf](#)

**Board Action Taken:**

Motion: \_\_\_\_\_

1) \_\_\_\_\_

2) \_\_\_\_\_

Aye/Nay

\_\_\_\_\_  
\_\_\_\_\_  
\_\_\_\_\_

---

(Vote Recorded By)

---

---

**Quad-County Regional  
Community Health Needs  
Assessment**

1

1

## Community Engagement



**Stakeholder Interviews**

**46 interviews**



**Focus Group Discussions**

**15 Focus Groups with  
over 125 participants**



**Surveys**

**Community Survey:**  
Over 1,551 responses

**Telephone Survey:**  
400 responses

*"It's not just the number of people; it's about being inclusive and connecting with the breadth of our highly diverse communities in a way that truly helps and engages them."*

2

2

## Organizations with Participation in Stakeholder Interviews & Focus Groups

- Boys & Girls Clubs Of Western Nevada
- Carson City Behavioral Health Task Force
- Carson City Fire Department
- Carson City Health And Human Services
- Carson City Sheriff's Office
- Carson Tahoe Behavioral Health Assertive Community Treatment
- Carson Valley Community Food Closet
- Carson Valley Medical Center
- Carson Valley Veteran's Affairs Clinic
- Community Chest, Inc.
- Douglas County Behavioral Health Task Force
- Douglas County School District
- Friends In Service Helping (FISH)
- Healthy Communities Coalition of Lyon And Storey Counties
- Lyon County Human Services
- Lyon County Juvenile Probation
- Lyon County Public And Behavioral Health Task Force
- Lyon County School District
- NAMI Western Nevada
- Nevada Association Of Counties
- Nevada Urban Indians
- PFLAG Carson City
- Nevada Division of Healthcare Financing and Policy
- Carson Medical Group
- Douglas County East Fork Fire Protection
- Storey Senior Citizens Center
- Turning Points Inc.
- Storey County Emergency Department
- Storey County Community Relations
- Nevada Dept. of Health and Human Services
- Division of Welfare and Supportive Services
- Nevada Business Group on Health
- JOIN Inc.
- Partnership Douglas County
- Ron Wood Family Resource Center
- Storey County Community Library
- Tahoe Youth & Family Services
- Washoe Tribe Health Center
- Western Nevada College
- Northern Regional Behavioral Health Policy Board

3

3

## Access Audit

- Thirty-six access audit or "mystery shopper" calls were made.
- Twenty-four (66.6%) were answered while the remaining were directed to a voicemail or not answered.
- All but one of the 24 facilities were accepting new patients. However, not all providers were accepting new patients.
- The wait list for primary care was generally between one and four months depending on the provider. However, urgent or "crisis" care appointments were available much sooner.
- Most sites had phone trees with only five offering the phone menu in Spanish.

4

4

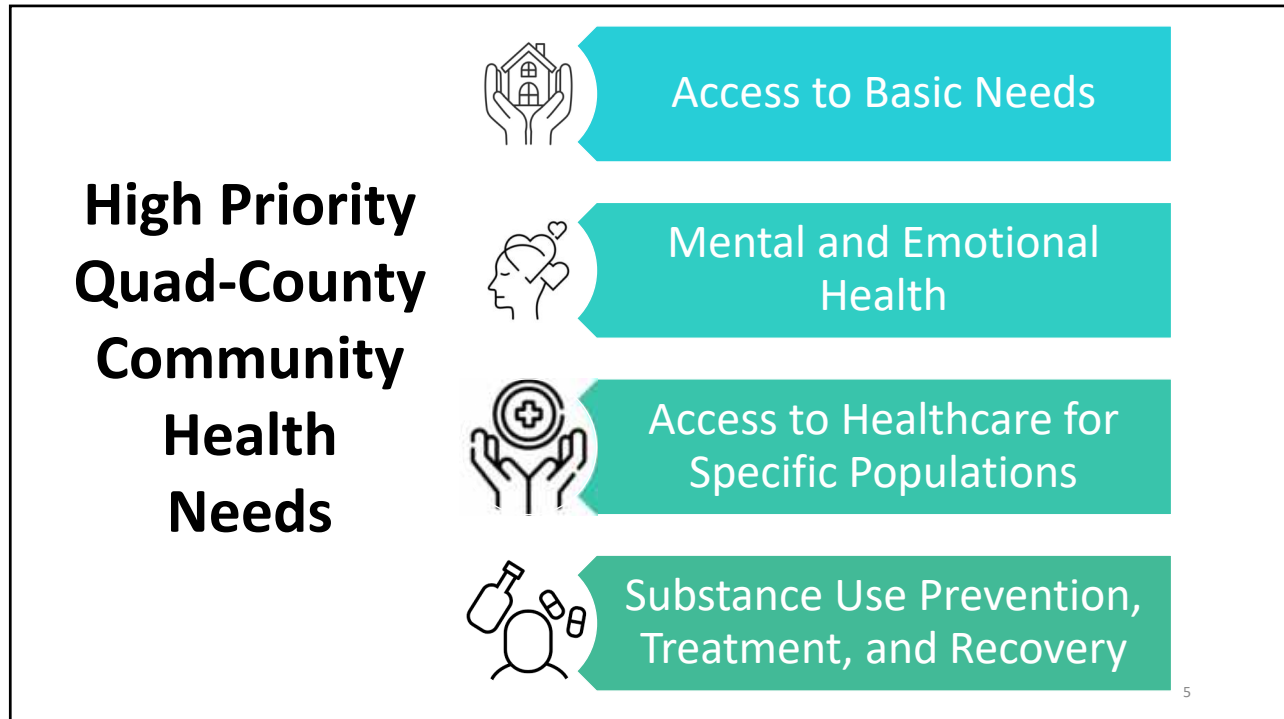

5

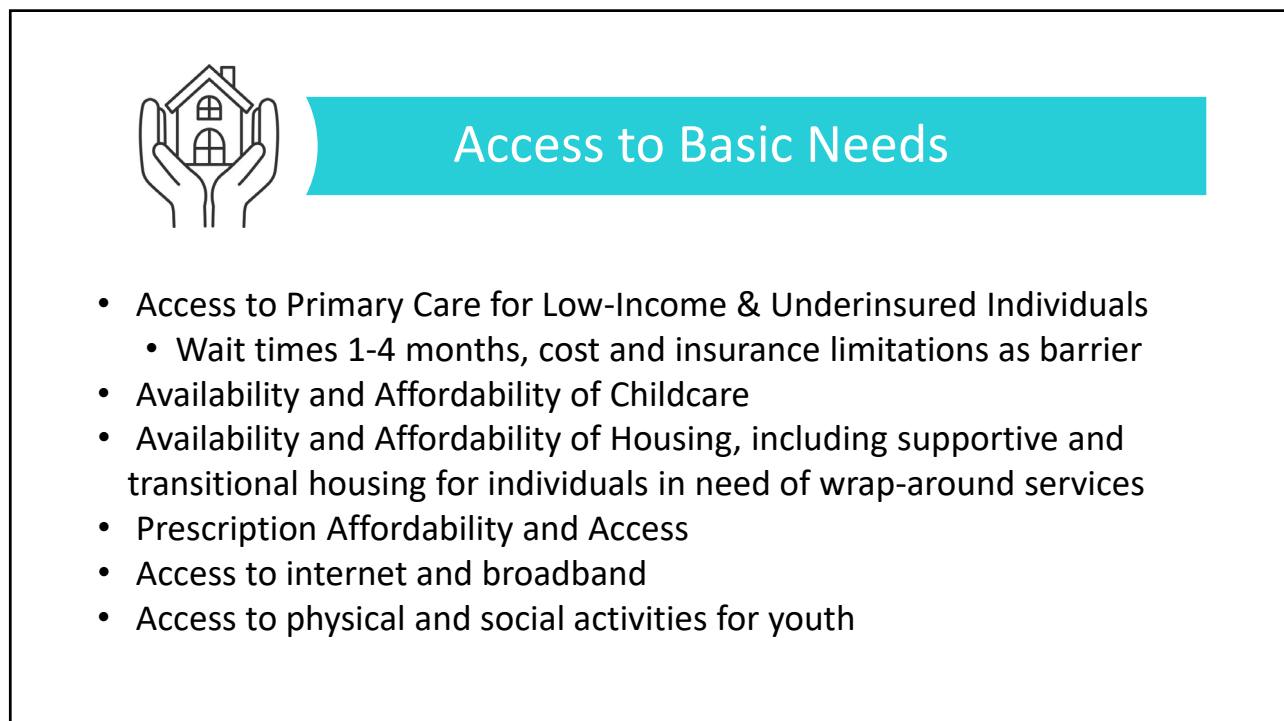

6

## Access to Safe, Affordable Housing

- #1 Highest Ranked Need Overall in the Community Survey

*"The housing stock is old and it's unsafe for many seniors. A lot of the staircases are very narrow. Many people live in travel trailers." - Storey County*

*"A lot of landlords are not willing to work with voucher-type programs. People wait to get Section 8 housing and then they end up living in their cars or doubling up or becoming homeless." - Carson City*

*"Rents are in the \$2,000 range and most of our clients live on less than \$900 a month. We've got motels that have transitioned to a monthly rate and people are paying \$900 a month to live in a facility with no kitchen or other amenities." - Focus Group Participant*

### Cost-burdened Households (More than 30% of Household Income on Housing Costs)

Source: U.S. Census Bureau, 2016-2020 American Community Survey Five-Year Estimates

	United States	Nevada	Carson City	Douglas County	Lyon County	Storey County
With a Mortgage	20.6%	23.0%	30.9%	34.6%	29.2%	27.7%
Without a Mortgage	10.4%	8.7%	10.2%	12.7%	11.2%	11.5%
Renter (35.0% or more)	40.0%	40.8%	29.6%	36.9%	36.2%	32.9%

7

7

## Affordable, Quality Childcare

- Ranked #4 Need Overall in the Community Survey

*"There has been increased truancy due to older children watching a younger child. They might miss a couple of days of school a week."*

*"There's one good facility and you need to get on the waiting list before you're even pregnant."*



*"In general, we need more childcare facilities, there are only five places. They don't take many kids and it's very expensive. Many parents don't work because it only covers gas and childcare. When COVID hit, I had three kids in day care and I paid \$1,700 every paycheck and I have a 50% discount."*

8

8



## Mental and Emotional Health

- Providers for both youth and adults including Peer Support Specialists, Community Health Workers, Clinical Professional Counselors, Licensed Clinical Social Workers, and Psychiatrists.
- Resource capacity across range of acuity:
  - Screening & Assessments
  - Outpatient services, including Intensive Outpatient Services
  - Inpatient services
  - Crisis care
- Programs/activities to reduce social isolation, increase support, and promote mental and emotional health

9

9

## Mental Health Counseling for Youth & Adults

- #2 (Adults) & #3 (Youth) Ranked Need in the Community Survey
- Shortage of Providers is Critical Issue

*"Seniors have a pretty high mental health burden. In June we had six completed senior suicides." - Douglas County*

*"We lack services for the youth. There is no funding or infrastructure for mental health. We don't have anything lower than an inpatient facility or the hospital. There is nothing in between." - Carson City*

*"Our biggest challenge is mental health. We don't have many outpatient psychiatrists, only one total, but they are not taking new patients. When we try to refer, there are no psychologists or therapists that are taking new patients. As primary care providers, we do a lot more therapy work and psychiatry medicine than what we are supposed to do." - Carson City*

*"On the pediatric side, we had kids in inpatient in the acute care hospital for months just waiting for a psych bed. It wasn't safe to send them home and there wasn't anywhere to send them locally. We had to send them all across the country just to find a psych bed."*

*- Carson City Community Member*

*"Our local providers are tapped. Our behavioral task force does have a lot of behavioral health providers and most of them have a week to three-week waitlist. South Lyon medical center has a little better access to mental health. Silver Springs doesn't really have anything." - Lyon County*

10



## Social Connection

People sometimes look to others for companionship, assistance, or other types of support. How often is each of the following kinds of support available to you if you need it? (None of the time, a little of the time, some of the time, most of the time, all of the time)

Measure reported is percentage of respondents who marked "none of the time" and "little of the time"

	Carson City	Douglas County	Lyon County	Storey County	Total
Someone you can count on to listen to you when you need to talk	35.1%	28.0%	34.6%	38.6%	<b>33.4%</b>
Someone to give you information to help you understand a situation	34.5%	31.3%	38.3%	44.6%	<b>35.1%</b>
Someone to turn to for suggestions about how to deal with a personal problem	35.3%	30.2%	39.0%	43.6%	<b>35.3%</b>
Someone to help you if you were confined to bed	36.8%	34.2%	41.7%	39.6%	<b>37.2%</b>
Someone to take you to the doctor if you needed it	34.3%	32.1%	36.6%	36.6%	<b>34.3%</b>
Someone who hugs you	39.5%	29.1%	35.0%	48.5%	<b>36.7%</b>
Someone to love and make you feel wanted	35.9%	31.5%	36.3%	38.6%	<b>35.0%</b>

crescendo 

11

11

**COVID-19 Impacts:** The past two years have been a challenge for all of us. Currently, are you having any challenges with the following? Reported as percent saying that this is a common or more frequent challenge.

	Carson City	Douglas County	Lyon County	Storey County	Total
Feeling lonely	37.4%	31.6%	34.9%	46.1%	<b>36.1%</b>
Enjoying leisure activities	36.2%	33.9%	34.3%	40.6%	<b>35.6%</b>
Managing major life issues such as relationship challenges, relocating, new job or change of school, loss of a loved one, or major illness	35.1%	34.1%	34.8%	34.3%	<b>34.7%</b>
Establishing and maintaining trusted relationships	34.8%	28.5%	33.7%	38.2%	<b>33.2%</b>
Getting along with people at work or in the community	32.2%	28.8%	33.3%	38.6%	<b>32.0%</b>
Getting along well with friends and family members	35.3%	26.3%	26.5%	39.6%	<b>31.7%</b>
Performing well at school or work	33.3%	25.4%	30.0%	46.9%	<b>31.7%</b>
Regular living activities such as getting to school or work on time, grocery shopping, or doing other common tasks	32.5%	24.6%	33.2%	42.2%	<b>31.3%</b>

12

12



## Access to Healthcare for Specific Populations

- Access to Specialty Care
  - Very few providers, significant travel and advance planning required
- Home Health across region
- Increased case management, treatment, and care coordination for people with complex chronic health problems
- Care for individuals with dementia/memory care needs
- Care for youth and adults with developmental disabilities
- **Competence of providers to serve specific populations, including knowledge of LGBTQ+ needs and increasing Spanish-speaking providers**
- Prevention & Treatment for Heart Disease, Kidney Disease, and Cancer

13

13

## Chronic Disease Prevalence: Quad-County 2019

	United States	Nevada	Carson City	Douglas County	Lyon County	Storey County
Asthma	9.6%	9.3%	9.0%	8.8%	9.6%	9.0%
COPD	6.2%	7.3%	6.6%	5.8%	7.3%	5.9%
Diabetes	10.6%	9.9%	9.5%	8.0%	9.8%	8.0%
Heart Disease	4.0%	4.2%	5.7%	5.5%	6.0%	5.1%
High Blood Pressure	32.3%	30.4%	29.0%	27.1%	29.5%	27.5%
Kidney Disease	2.9%	2.7%	2.9%	2.5%	2.9%	2.5%
Stroke	3.2%	2.8%	3.0%	2.6%	3.2%	2.7%
Obesity	32.1%	30.4%	31.2%	31.3%	36.2%	28.9%

Source: National Center for Chronic Disease Prevention and Health Promotion, Division of Population Health. Behavioral Risk Factor Surveillance System, 2019 (Note: most recent data available by county)

14

14

## People Living with a Disability by Difficulty

### People Living with a Disability by Difficulty

Source: U.S. Census Bureau, 2016-2020 American Community Survey Five-Year Estimates

	United States	Nevada	Carson City	Douglas County	Lyon County	Storey County
Hearing Difficulty	3.6%	3.8%	7.0%	6.1%	5.5%	9.0%
Vision Difficulty	2.4%	2.7%	4.4%	2.7%	3.2%	6.0%
Cognitive Difficulty	5.1%	4.6%	6.3%	4.5%	6.4%	10.3%
Ambulatory Difficulty	6.8%	7.0%	9.0%	7.5%	9.6%	14.5%
Self-Care Difficulty	2.6%	2.5%	3.7%	2.5%	4.4%	7.3%
Independent Living Difficulty	5.8%	5.3%	6.4%	4.6%	7.5%	9.2%

15

## Community Survey: Reason for Not Getting Needed Care

- 3 out 4 of survey respondents answered "yes" to the following question: **In the past two years, has there been one or more occasions when you needed medical or mental health care but chose NOT to get it?**

	Carson City	Douglas County	Lyon County	Storey County	Total
Lack of money/ability to pay	17.8%	16.5%	19.2%	18.5%	17.7%
Long wait times to see a provider	16.3%	17.2%	16.7%	13.0%	16.4%
Did not feel comfortable with available providers	15.6%	12.5%	21.0%	24.1%	16.3%
COVID-19 related restrictions	12.1%	12.5%	14.5%	18.5%	13.1%
Providers are not culturally competent	11.7%	10.6%	15.9%	21.3%	12.8%
Lack of health insurance	14.2%	7.3%	13.4%	18.5%	12.4%
Providers not knowledgeable about people with my sexual orientation or gender status	10.9%	10.6%	12.3%	23.1%	11.9%
Providers did not speak my language	12.0%	9.4%	9.4%	16.7%	11.2%
Doctor's office is too far from my house	10.5%	6.8%	13.0%	20.4%	10.6%
Concern about my immigration status	10.1%	7.5%	10.9%	18.5%	10.1%
Lack of transportation	8.5%	5.9%	11.2%	13.0%	8.6%

16



## Substance Use Prevention, Treatment, and Recovery

- Need capacity across range of acuity:
  - Drug and other substance use prevention and early intervention programs
  - Drug and other substance use treatment services, including Intensive Outpatient Services, Groups, and community-based treatments.
  - Programs and services to support individuals in recovery
- For youth, increased coordination between school systems and community providers and agencies to address prevention and early intervention

17

17

## Substance Use: Voices from the Region



*"Meth has always been prevalent – cheap, fast, easy to make. Alcohol continues to be an issue."* - Lyon County

*"Fentanyl is on the rise and being mixed into other substances. It's certainly not getting better."* - Carson City

*"Alcohol use has gone down in the school system. Pills are a problem - usually oxys or hydrocodone, other opiates. Vaping is out of control."* - Douglas County

*"Opioids are a big problem here. As first responders, we are starting to see a greater number of calls on opioid overdoses. Alcohol is a major issue here as well, especially with our homeless."* - Carson City

*"There are a lot of opioids, meth, and Fentanyl. It just seems like everywhere I turn someone is getting poisoned to death."* - Douglas County

*"When you look at our general arrest rates, what they are tied to, and root causes of people seeking social services, it comes down to an unhealthy coping mechanism, which is usually alcohol, which can lead to poly substance use. The severe drug use is concerning meth. Recently we have been seeing more and more opioid use."* -Lyon County

18

18

## Where to Access the Full Report

- Requests for copies and comments on the report can be submitted to [community@carsontahoe.org](mailto:community@carsontahoe.org)
- Executive Summary and Full Report available on CCHHS website at [www.gethealthycarsoncity.org](http://www.gethealthycarsoncity.org)

Thank you to everyone who lent their voice and expertise to the project!

19

19

## Next Steps and ...



crescendo 

20

20

- Community Health Improvement Plan (CHIP)
  - Robust collaborative effort
  - Diverse partners
- Comments, Feedback, and Questions



CARSON TAHOE  
HEALTH



## 2022 QUAD-COUNTY REGIONAL

# COMMUNITY HEALTH NEEDS ASSESSMENT

## EXECUTIVE SUMMARY

A coalition of eight community agencies came together to complete this Community Health Needs Assessment (CHNA). The goal of this assessment is to determine the most pressing health-related needs from the perspective of community members themselves. A variety of data sources were used including focus groups, phone interviews, national and state government reports and data, and a robust communities-wide online survey.

Altogether, the report tells a story of a resilient, collaborative community ready to meet the many health-related challenges of today and tomorrow to build a healthier future for all.

COMPILED FOR CARSON TAHOE HEALTH  
ON BEHALF OF THE QUAD COUNTIES BY:



## Our Purpose: A Healthier Community For All

This Quad-County Community Health Needs Assessment (CHNA) serves as a critical phase in the overall effort to improve community health. Through the collaborative CHNA process, we create a snapshot of community health perceptions, health behaviors, and disparities. We develop an inventory of community assets and resources available to catalyze progress, and we reach consensus on our top community health priorities.

### We commit to work together to achieve a healthier tomorrow.



The Quad-County CHNA Planning Committee worked with its assessment partner Crescendo Consulting Group to formalize and deploy a highly inclusive Assessment-As-Action-Cycle framework that included a community-wide email survey (English & Spanish), stakeholder interviews, focus groups, an access audit, equity champions outreach, secondary research, and stakeholder commitment to collaboratively develop strategies and solutions in response to identified needs.

At the conclusion of the process, a prioritized list of top community need domains was established (see page 4). The methodology included a mixed modality approach – quantitative, qualitative, and technology-based techniques – to learn about the human stories and voices while weaving them with the best available data.

### By the numbers...

- 46 stakeholder interviews across the region
- 15 focus groups with over 125 participants total
- 1,551 community survey respondents
- 400 participants in random digit dialing telephone survey

### How can I use the report?

The report creates a shared frame of reference for local health and government agencies, not-for-profit organizations, lawmakers, employers, advocates, businesses, and every community member across the Quad-County region.

Let the data **guide collective planning**. Let the community voices – stories of need, but also of possibility – **inspire action**. Let this report **prompt every individual to consider their own ability to impact the health of just one neighbor, one friend, one stranger...** until everyone has the support and resources they need to live their healthiest life.



## Community Description & Population Demographics

The community defined for this assessment is delineated by Carson Tahoe Health’s Primary Service Area ZIP codes (referred to as CTH PSA in this report) and by Carson City, Douglas, Lyon, and Storey Counties, collectively known as the Quad-County Region.

### Carson Tahoe Health’s Primary Service Area (CTH PSA)



Source: UDS Mapper<sup>1</sup>

### Quad-County Region



Source: *gisgeography.com* modified by CTH



Source: <https://gethealthycarsoncity.org/nov-el-coronavirus-2019/>

The total population of the Quad-County Region is expected to expand rapidly over the next decade. The population in Nevada is projected to grow from 3,173,326 in 2021 to 3,469,124 in 2031 (9.3%).

<sup>1</sup> UDS Mapper. Carson Tahoe Health Primary Service Area. Link: [https://maps.udsmapper.org/map?map\\_id=QvD2XVqleQvrzmjANnbk](https://maps.udsmapper.org/map?map_id=QvD2XVqleQvrzmjANnbk)



## Summary of Community Prioritized Domains & Needs

### Access to Basic Needs



- Access to Primary Care, including for Low-Income & Underinsured Individuals
- Availability and Affordability of Childcare
- Availability and Affordability of Housing, including supportive and transitional housing for individuals in need of wrap-around services
- Prescription Affordability and Access
- Access to internet and broadband
- Access to physical and social activities for youth

### Mental and Emotional Health



- Providers for both youth and adults including Peer Support Specialists, Community Health Workers, Clinical Professional Counselors, Licensed Clinical Social Workers, and Psychiatrists.
- Resource capacity across range of acuity
  - Screening & Assessments
  - Outpatient services, including Intensive Outpatient Services
  - Inpatient services
  - Crisis care
- Programs/activities to reduce social isolation, increase support, and promote mental and emotional health

### Access to Healthcare for Specific Populations



- Access to Specialty Care
- Home Health Care across region
- Increased case management, treatment, and care coordination for people with complex chronic health problems such as diabetes
- Prevention and Treatment for Cardiovascular Disease, Kidney Disease, and Cancer
- Care for individuals with dementia/memory care needs
- Care for youth and adults with developmental disabilities
- Competency of providers to serve specific populations, including knowledge of LGBTQ+ needs and increasing Spanish-speaking providers
- Transportation to medical appointments

### Substance Use Prevention, Treatment, and Recovery



- Need capacity across range of acuity
  - Drug and other substance use prevention and early intervention programs
  - Drug and other substance use treatment services, including Intensive Outpatient Services, Groups, and community-based treatments.
  - Programs and services to support individuals in recovery
- For youth, increased coordination between school systems and community providers and agencies to address prevention and early intervention

## Summary of Findings



### Access to Basic Needs

The global COVID-19 pandemic impacted virtually everyone on the planet, however, it has disproportionately impacted more vulnerable populations, including locally in the Quad-County Region. Many struggle to have their basic needs met, which impacts their ability to get and stay healthy. Some of the top community needs identified throughout the primary and secondary research include access to basic needs such as affordable housing, childcare, affordable and accessible prescriptions, and access to healthcare services for low-income individuals.

### Housing

The United States is currently in an affordable housing crisis that was brewing long before the COVID-19 pandemic, but escalated during the pandemic for a variety of reasons. According to the National Low Income Housing Coalition, there is a housing shortage of 7 million available and affordable rental units for extremely low-income renters, whose household incomes are at or below the federal poverty guidelines or 30% of their area median income<sup>2</sup>.

*“Rents are in the \$2,000 range and most of our clients live on less than \$900 a month. We've got motels that have transitioned to a monthly rate and people are paying \$900 a month to live in a facility with no kitchen or other amenities”. - Focus Group Participant*

Across the Quad-County Region, residents face a variety of housing challenges. Many stakeholders voiced challenges surrounding themes of affordable housing, housing stock, and a lack of resources for those experiencing housing insecurities. The lack of affordable housing is affecting residents of all income levels for both home buying and rentals. Low-income housing is limited across the region.

Many community residents identified the rising costs of rents and home prices as a top community need in the Quad-County Region. Cost-burdened households is a metric commonly used to identify potentially struggling households. Approximately one in three renter households in the Quad-County Region pay more than 35% of their household income in rent. Additionally, approximately one in three households with a mortgage are also cost-burdened, which is higher than the state and national percentage. Households that need to spend more on housing costs are less likely to be able to afford other necessities such as food, clothing,

<sup>2</sup> National Low Income Housing Coalition. The Gap. <https://nlihc.org/gap>

transportation, medical care, childcare, and more. For additional information on housing instability and cost, housing stock trends, homelessness, and more see pages 106-112 of the full CHNA report.

## Childcare

*“There has been increased truancy due to older children watching a younger child. They might miss a couple of days of school a week.”*

- Community Stakeholder

The COVID-19 pandemic has put the childcare crisis in the national limelight over the past few years. The childcare industry has always been fragile and plagued with sustainability challenges from both the family and childcare provider sides, and COVID-19 restrictions only exacerbated the crisis. Childcare is often the biggest barrier for parents and caregivers, especially single moms, to

entering and maintaining employment. In addition to limited capacity, the cost of childcare is expensive with the average family paying approximately \$10,174 a year in childcare costs<sup>3</sup>, which is approximately 10% of the median income for a married couple and more than 35% of the median income for a single parent.

Affordable quality childcare was ranked as the fourth highest need in the community survey and ranked seventh in the telephone survey (See page 87 of the “Quantitative Community Survey” section of the full CHNA report for more rankings, and “Voices of Douglas County” on page 46 for more on childcare).

## Affordable and Accessible Prescriptions

Approximately one in three residents in the Quad-County Regional has at least one chronic disease, with hypertension (high blood pressure) and obesity having the highest prevalence rates (See pages 174-176 of the full CHNA report for more on chronic disease outcomes). The chronic disease prevalence rates for older adults are even higher. Many chronic diseases are treated with prescription medication. A 2019 KFF Health Tracking Poll<sup>4</sup> on prescription drugs revealed that about one in four adults say that it is “difficult” to afford their prescription medications and one in three adults reported not taking their medicines as prescribed in the past 12 months because of costs.

<sup>3</sup> ChildCare Aware of America. Demanding Change. <https://info.childcareaware.org/hubfs/FINAL-Demanding%20Change%20Report-020322.pdf>

<sup>4</sup> KFF. KFF Health Tracking Poll – February 2019: Prescription Drugs. <https://www.kff.org/health-costs/poll-finding/kff-health-tracking-poll-february-2019-prescription-drugs/>

*“There are no pharmacies here. We use Access to Healthcare (out of Reno), and they work with insurance. We have a post office, but you have to pick medication up, and for online meds, it has to be ordered online.”*

*– Storey County community member*

Access to affordable prescription drugs was ranked as the fifth highest need in the community survey overall and the top need for individuals younger than 35. Access to affordable prescription drugs was ranked third on the telephone survey. While affordability is one of the biggest challenges to prescription drugs, it is also the access to pharmacies in more rural communities that can be a barrier, especially for individuals without reliable transportation.

### Access to Healthcare Services for Low-Income Individuals

The median annual household income varies across the region from \$71,415 in Douglas County to \$58,305 in Carson City. While the percentage of households living below the Federal Poverty Level (FPL) is less than the state and national population, approximately one in ten households live below 100% FPL in the Quad-County Region.

Additionally, the percentage of uninsured individuals across the region varies by county from 10.1% in Carson City to 7.2% in Douglas County. It is estimated that approximately one in four adults with employer health plans are considered underinsured and likely struggle to pay for out-of-pocket healthcare costs. Check out the full report for more data on economically disadvantaged populations (pages 104-105), the uninsured community (pages 150-153), and the underinsured community (pages 154-157).

PERCENTAGE OF COMMUNITY  
MEMBERS WHO NEED CARE  
BUT CHOSE NOT TO GET IT

73%

In the community survey, approximately three in four survey respondents (73%) said that within the past two years there has been at least one occasion where they needed medical or mental healthcare, but chose not to get it. The most common reason was lack of money or ability to pay followed by long wait times to see providers. Additionally, the survey respondents ranked “affordable healthcare services for individuals and families with low income” as the eighth top community need.



## Mental and Emotional Health

The 2022 State of Mental Health in America<sup>5</sup> reported that 19.86% of adults experienced a mental health illness in 2019. The report also found there is a growing percentage of youth living with major depression, and suicidal ideation continues to increase among adults. The COVID-19 pandemic has had a huge impact on the mental health of individuals across the country and the long-term impacts are yet to be fully discovered.

Access to mental health services is one of the most critical needs across the Quad-County Region as identified by the qualitative research and community and telephone surveys. Themes found across the counties included challenges in timely access, shortage of mental health providers, cost, and an increase demand of mental health services since the beginning of the pandemic.

### Providers for Youth and Adults

Mental health services specifically for youth and adults is an urgent and dire need in every community that participated in the qualitative research process. There are workforce shortages in mental health pediatric providers and mental health capacity within the schools, a shortage of education providers, and substance use concerns in the youth population.

In the community survey, counseling services for adults ranked number two below affordable housing followed by counseling services for youth at number three. When the community survey was further analyzed by age group, counseling services for youth was the top community need for survey respondents aged 55 and older. Counseling services for youth ranked the second top community need in the telephone survey.

Additionally, the University of Nevada Reno School of Medicine’s Office of Statewide Initiatives’ Nevada Instant Atlas indicates that there is a shortage of psychiatrists in the Quad-County Region. However, there are a greater number of psychologists available in the community, and also other providers of behavioral health care including Clinical Professional Counselors and Peer Support Specialists. For more on healthcare workforce challenges, see pages 159-169 of the full report.

*“The available data for behavioral health providers in the region, while alarming in itself, does not speak to the severity of need for youth providers. Very few providers (if any, for parts of the region) specialize in youth or are able to support youth in any capacity.”*

— Leadership Group Member

<sup>5</sup> Mental Health America. The State of Mental Health in America. <https://mhanational.org/issues/state-mental-health-america>

## Capacity Needed Across Acuity

The mental health needs span the various levels of acuity from early screening and assessment, to outpatient services, to crisis and long-term care. The Quad-County Region does have some designated mental health beds, but access is limited due to barriers such as age of patient and insurance type. Finding beds for youth in crisis is especially difficult at times. With schools moving to remote models over the course of the pandemic, early intervention and prevention, especially among youth, was less robust and is now more important than ever.

*“On the pediatric side, we had kids in inpatient in the acute care hospital for months just waiting for a psych bed. It wasn't safe to send them home and there wasn't anywhere to send them locally. We had to send them all across the country just to find a psych bed.”*

*- Carson City Community Member*

## Social Connectivity

A 2020 Health Affairs Health Policy Brief<sup>6</sup> reported that social isolation is a significant contributor to morbidity and early mortality. With COVID-19 restrictions, schools and offices going remote, many people across the country were isolated at home for long periods of time.



The CHNA community survey asked a series of questions on social connectedness to begin to understand the extent of the challenges in the community. Across geographies, no fewer than one in five respondents, and most commonly, at least one in three respondents, reported that the various types of support were available to them “none” or “a little of the time.”

For additional measures of social connection, community engagement, and belonging in the region, see pages 76-79 of the full report.

<sup>6</sup> Health Affairs. Social Isolation and Health. <https://www.healthaffairs.org/content/briefs/social-isolation-and-health>





## Access to Healthcare for Specific Populations

The Institute of Medicine defined access to healthcare as “the timely use of personal health services to achieve the best health outcomes<sup>7</sup>” in 1993. Healthy People 2020 further defined access to healthcare as four components: coverage, services, timeliness, and workforce<sup>8</sup>. Throughout the Quad-County Region, community residents have identified challenges to accessing healthcare services, especially in more rural communities. While access to primary care services was relatively good, stakeholders and focus group participants identified access to specialty care as more challenging. Additionally, provider competency to serve specific populations and transportation were also identified as top access to healthcare needs in the Quad-County Region.

### Access to Specialty Care

Higher chances of hospitalization and mortality are seen in residents who live in rural areas with limited access to specialist providers. Research has shown that patients who see a specialist in addition to their primary care provider are less likely to be hospitalized and die from a preventable disease.<sup>9</sup>

Timely access to see providers and a shortage of specialists is an identified need that came across during stakeholder interviews and focus groups.

Some stakeholders identified the need for specific types of providers like pediatricians, endocrinologists, OBGYNs, and other medical specialists. Many community residents need to travel to Carson City (from Douglas, Lyon, or Storey Counties) or Reno to access specialty care in a timely manner.

Additionally, the University of Nevada Reno School of Medicine’s Office of Statewide Initiatives’ Nevada Instant Atlas medical specialist counts indicate that there is a shortage of specialty care providers in the more rural counties, such as Lyon and Storey Counties. Carson City has a slightly higher rate of specialists than Nevada as a whole.

*“There is a lack of timely access to specialists. Where I am at, I try to get someone in with a neurologist and gastrologist; it takes two to three months, rheumatology is six months out.”*

– Stakeholder from Lyon County

<sup>7</sup> IOM. Access to Health in America. <https://www.ncbi.nlm.nih.gov/books/NBK235882/>

<sup>8</sup> HealthPeople.gov. Access to Health Services. <https://wayback.archive-it.org/5774/20220413202227/https://www.healthypeople.gov/2020/topics-objectives/topic/Access-to-Health-Services>

<sup>9</sup> Health Affairs. Lack of Access to Specialists Associated with Mortality and Preventable Hospitalizations of Rural Medicine Beneficiaries, 2019 <https://www.healthaffairs.org/doi/10.1377/hlthaff.2019.00838>

## Health System Competency & Access for Specific Populations

In addition to a shortage of medical providers, provider competency, especially for the LGBTQ+ and Spanish-speaking populations, was identified as a top community need. The Hispanic or Latino population is the fastest growing population in the Quad-County Region. Approximately one in five individuals in Carson City speaks Spanish. For more on community demographics, including data on population growth, median age, diversity index, and more, see pages 12-22 of the full CHNA report.

- **Linguistic Isolation**

Language barriers can be a significant deterrent to accessing healthcare. People who do not speak English well are less likely to seek healthcare or receive health information. This can lead to delay of care and missed health screenings for chronic disease and cancers. Language isolation is also linked to poor mental health.

*“Too many providers say that if you live in this country that you need to speak English. It’s demeaning and it turns that Hispanic person off from seeking medical care.”*

- Douglas County Community Member

PERCENTAGE OF NEVADANS THAT  
SPEAK A LANGUAGE  
OTHER THAN ENGLISH

30.2%

Over one-fifth of the population (22.4%) in Carson City speaks a language other than English, which is higher than the national percentage (21.5%). Over 11.0% of the CTH PSA population speaks Spanish. Approximately one-tenth of the populations in Douglas and Lyon Counties speak Spanish.

*“Access to mental healthcare is challenging for Spanish-speaking communities. For the kids, they speak English so it is not a problem to have a therapist that only speaks English, but for the parents it’s hard part because they don’t speak English. There are not many Spanish-speaking therapists and mental health providers. For adults that don’t speak English, they can use an interpreter, but a lot is lost in translation.”*

- Community Stakeholder



- **Provider Competency to Serve LGBTQ+ Individuals**

LGBTQ+ community members have significantly higher percent of depressive disorder diagnoses and more days of poor mental health.<sup>10</sup> In Nevada, gay, lesbian, and/or bisexual students were twice as more likely to be bullied on school property according to the 2019 Youth Behavioral Risk Factor Surveillance System. For more of LGBTQ+ health and risk factors, see pages 213-215 of the full report.

*“Providers are not trained, especially for transgender individuals. Youth are now coming out and transitioning at younger ages. We need doctors who are trained to work with young transgender individuals.”*

*- Carson City Community Member*



Several stakeholders, including several Equity Champions, identified the need for healthcare providers who understand the unique health needs of transgender people, especially youth, in the community. Additionally, one local stakeholder shared how limited access to specialty care impacts LGBTQ+ individuals: “There is a huge need for endocrinology for transgender care.”

## Transportation

Across the Quad Counties, community members mentioned challenges in accessing transportation to medical appointments and services around the community in particular. Unreliability, timely access, and subpopulation criteria for public transportation were specific challenges shared.

Public transportation can impact a person’s health and influence health equity. Lack of transportation can cause an individual to miss their health appointments, or to delay

*“Transportation for elderly - sometimes they have to sit in the waiting room for hours waiting to be picked up and they get a timeframe such as a three-hour window, and they're just sitting in the waiting room for someone to get them.” – Stakeholder*

scheduling, which can cause poorer health outcomes and added health expenditures. Reliable transportation can improve stability in access to health, nutrition, employment opportunities, and social inclusion. Transportation ranked 26 on the community survey, however, it ranked higher in Storey (8) and Lyon (14) Counties compared to the other service areas.

<sup>10</sup> Nevada SAPTA EPI Profile, 2019. Link: [/dhhs.nv.gov/uploadedFiles/dhhsnv.gov/content/Programs/Office\\_of\\_Analytics/SAPTA\\_EPI\\_Profile\\_Nevada\\_2019.pdf](https://dhhs.nv.gov/uploadedFiles/dhhsnv.gov/content/Programs/Office_of_Analytics/SAPTA_EPI_Profile_Nevada_2019.pdf)



## Substance Use Prevention, Treatment, and Recovery

A recent Kaiser Family Foundation report, Recent Trends in Mental Health and Substance Use Concerns Among Adolescents, reported that deaths due to drug overdose in adolescents nearly doubled nationally in the first year of the pandemic.<sup>11</sup>

*“There are a lot of opioids, meth, and Fentanyl. It just seems like everywhere I turn someone is getting poisoned to death.”* Stakeholder from Douglas County

Additionally, a third of high school students reported using substances such as alcohol, tobacco, marijuana, and misuse of prescription opioids in 2021. As of April 2022, over 100,000 people have died of drug overdose largely due to fentanyl.<sup>12</sup>

Through conversations with stakeholders and focus group participants in the Quad-County region, it was clear that substance use prevention, treatment, and recovery programs are vital to the overall health of the community. Survey respondents ranked these needs as follows:

**#9 Ranked Need - Programs to Help Patients in Recovery Stay Healthy**

**#13 Ranked Need - Substance Use Treatment Services**

**#15 Ranked Need - Substance Abuse Early Intervention Services**

Data from the State of Nevada Department of Health & Human Services Office of Analytics reported that between 2017 and 2019, Lyon County experienced the highest rate of substance use-related deaths per 100,000 population, over twice as high compared to Douglas County. Several stakeholders indicated that there are very little prevention programs, especially for youth, due in part to lack of funding as well as restrictions on available funding.

- Between 2019 and 2020, Nevada experienced a 55.0% increase in drug-related overdose deaths. In 2020, 788 drug-related overdose deaths occurred. Of those deaths, 65.2% were attributable to opioids.<sup>13</sup>
- Between 2019 and 2020, the opioid-related overdose death rate increased in three out of four service area counties, with Carson City alone reporting a decrease. Douglas County experienced the most severe increase from 5.1 deaths to 18.1 deaths per 100,000 population.

<sup>11</sup> KFF. Recent Trends in Mental Health and Substance Use Concerns Among Adolescents. <https://www.kff.org/coronavirus-covid-19/issue-brief/recent-trends-in-mental-health-and-substance-use-concerns-among-adolescents/#:~:text=Some%20research%20has%20shown%20that,in%20substance%20use%20in%202021.>

<sup>12</sup> CDC. Provisional Drug Overdose Death Counts. <https://www.cdc.gov/nchs/nvss/vsrr/drug-overdose-data.htm>

<sup>13</sup> Nevada Department of Health & Human Services, Nevada State Unintentional Drug Overdose Reporting System: Report of Deaths 2019 to 2020 – Statewide 2020. Link: [nvopioidresponse.org/wp-content/uploads/2019/05/sudors\\_report\\_2019\\_2020.pdf](http://nvopioidresponse.org/wp-content/uploads/2019/05/sudors_report_2019_2020.pdf)

This Executive Summary is a small snapshot of the data collected for Quad-County Regional Community Health Needs Assessment. The full report includes additional community voices, survey measures, and secondary data for the region across a range of health outcome and social determinants of health measures, including:

- Full Community Survey Findings
- Telephone Survey Findings
- Economic Stability
- Neighborhood & Physical Environment
- Education
- Food Access
- Community & Social Context
- Local Healthcare System & Workforce
- Health Status, Chronic Disease, & Outcomes
- Mental Health of Older Adults
- Youth Behavioral Health
- Substance Use
- The Opioid Epidemic
- ....and, more!

The full report is available through the Carson Tahoe Health website ([www.carson Tahoe.com](http://www.carson Tahoe.com)), the Carson City Health & Human Services website (<https://getthehealthycarsoncity.org/>), and with partner organizations across the Quad County Region. Requests for copies and comments can be submitted to [community@carsontahoe.org](mailto:community@carsontahoe.org).

On behalf of the organizations who led this work, a huge thank you to our community members who shared their time, insights, expertise, and perspectives.

### **Join Us!**

**We invite you to participate in the next step – Community Health Improvement Plans! Monitor partner organizations' social media, websites, and announcements for more information.**

## QUAD-COUNTY REGIONAL COMMUNITY HEALTH NEEDS ASSESSMENT

A coalition of eight community agencies came together to plan this Community Health Needs Assessment (CHNA), and additional agencies supported through equity champion participation.

**Carson Tahoe Health** is a comprehensive healthcare network featuring two hospitals, two urgent cares, an emergent care center, outpatient services, and a provider network with 21 regional locations servicing communities across Northern Nevada and the Eastern Sierras. <https://www.carsontahoe.com/>

**Carson City Health & Human Services** aims to protect and improve the quality of life of our community through disease prevention, education, and support services. <https://gethealthycarsoncity.org/>

**Community Chest, Inc.** is a leader at working with communities and joining hands with others to provide blended and integrated health and human services across the spectrum – from early childhood education to comprehensive mental health supports – throughout rural Nevada so that all may have access to the resources they need to not only survive but thrive. <https://communitychestnevada.net/>

**Nevada Association of Counties** strives to encourage county government to provide services that will maximize efficiency and foster public trust in county government. <https://www.nvnaco.org/>

**Partnership Douglas County** is committed to serving Douglas County and beyond and their staff are active voices for health policy and program innovation. <https://www.pdcnv.org/>

**Lyon County Human Services** works to enhance the well-being of individuals and families across the lifespan. They believe that it is their primary responsibility to provide for the human service needs of Lyon County's residents, especially those most at risk. <https://www.lyon-county.org/175/Human-Services>

**Quad-County Public Health Preparedness**, housed within Carson City Health & Human Services, aims to build relationships and break down silos between agencies that represent the healthcare system in Carson City, Douglas, Lyon, and Storey counties. <https://gethealthycarsoncity.org/preparedness/>

**Douglas County Community Services, Parks, & Recreation** works to create and preserve quality parks and recreation opportunities, servicing people of all ages and interests, that positively affect the community and enrich life. <https://communityservices.douglascountynv.gov/>

Special thanks to our Equity Champions from the following organizations for helping to bring the voices of specific populations, often underrepresented in healthcare, into our work:

- **PFLAG Carson City** (<https://pflagcarson.org/>)
- **Carson Valley Community Food Closet** (<https://www.thefoodcloset.org/>)
- **Partnership Douglas County** (<https://www.pdcnv.org/>)
- **NAMI Western Nevada** (<https://namiwesternnevada.org/>)





CARSON TAHOE  
HEALTH



# 2022 QUAD-COUNTY REGIONAL

# COMMUNITY HEALTH NEEDS ASSESSMENT

A coalition of eight community agencies came together to complete this Community Health Needs Assessment (CHNA). The goal of this assessment is to determine the most pressing health-related needs from the perspective of community members themselves. A variety of data sources were used including focus groups, phone interviews, national and state government reports and data, and a robust community-wide online survey.

Altogether, the report tells a story of a resilient, collaborative community ready to meet the many health-related challenges of today and tomorrow to build a healthier future for all.

COMPILED FOR CARSON TAHOE HEALTH  
ON BEHALF OF THE QUAD COUNTIES BY:





A coalition of eight community agencies came together to complete this Community Health Needs Assessment (CHNA).

**Carson Tahoe Health** is a comprehensive healthcare network featuring two hospitals, two urgent cares, an emergent care center, outpatient services, and a provider network with 21 regional locations servicing communities across Northern Nevada and the Eastern Sierras.

**Carson City Health & Human Services** aims to protect and improve the quality of life of our community through disease prevention, education, and support services.

**Community Chest, Inc.** is a leader at working with communities and joining hands with others to provide blended and integrated health and human services across the spectrum – from early childhood education to comprehensive mental health supports – throughout rural Nevada so that all may have access to the resources they need to not only survive but thrive.

**Nevada Association of Counties** strives to encourage county government to provide services that will maximize efficiency and foster public trust in county government.

**Partnership Douglas County** is committed to serving Douglas County and beyond and their staff are active voices for health policy and program innovation.

**Lyon County Human Services** works to enhance the well-being of individuals and families across the lifespan. They believe that it is their primary responsibility to provide for the human service needs of Lyon County's residents, especially those most at risk.

**Quad-County Public Health Preparedness**, housed within Carson City Health & Human Services, aims to build relationships and break down silos between agencies that represent the healthcare system in Carson City, Douglas, Lyon, and Storey counties.

**Douglas County Community Services, Parks, & Recreation** works to create and preserve quality parks and recreation opportunities, servicing people of all ages and interests, that positively affect the community and enrich life.

## Contents

<b>Introduction: Quad-County Regional Community Health Needs Assessment</b>	<b>7</b>
<b>Purpose</b>	<b>7</b>
<b>Importance of the Collaborative Approach</b>	<b>8</b>
<b>CHNA Methodology</b>	<b>10</b>
Operational Framework	11
<b>Community Description &amp; Population Demographics</b>	<b>12</b>
<b>Prioritization Process and Results</b>	<b>23</b>
Needs Prioritization Process	23
Prioritized Community Need Domains & Needs	24
<b>Summary of Findings</b>	<b>25</b>
Access to Basic Needs	26
Access to Healthcare for Specific Populations	30
Mental and Emotional Health	34
Substance Use Prevention, Treatment, and Recovery	38
<b>Qualitative Research Approach</b>	<b>40</b>
<b>One-on-One Interviews</b>	<b>40</b>
<b>Focus Group Discussions</b>	<b>40</b>
<b>Qualitative Data Collection Participants</b>	<b>41</b>
<b>Insights into the Quad-County Region</b>	<b>42</b>
Sample voices from the Community	42
<b>County-Level Action Areas</b>	<b>43</b>
Voices of Carson City	44
Voices of Douglas County	46
Voices of Lyon County	48
Voices of Storey County	50
<b>Quad-County Region High-Level Action Areas from Qualitative Data Collection</b>	<b>52</b>
Housing	53
	3

Mental Health	56
Specialty Healthcare	59
Substance Use	61
Transportation	63
<b>Potential Solutions</b>	<b>65</b>
<b>Quantitative Community Survey</b>	<b>66</b>
<b>Survey Methodology</b>	<b>66</b>
Online Community Survey	66
Telephone Survey	66
<b>Community Survey Demographics</b>	<b>67</b>
<b>Community Survey Findings</b>	<b>69</b>
Routine Care	69
Occasions When Not Getting Needed Care	70
Reasons for Not Getting Needed Care	71
Community Profile	74
Community Engagement & Belonging	76
Social Connectedness	78
Pelvic Pain	80
Other Reproductive Health Issues	81
Unmet Health Needs	82
Impact of COVID-19	84
Community Survey Prioritized Needs Results	87
<b>Telephone Survey Demographics</b>	<b>90</b>
<b>Telephone Survey Findings</b>	<b>92</b>
Community Engagement	92
Prioritized Needs	93
<b>Demographic Comparison: Surveys vs. Secondary Data</b>	<b>94</b>
<b>Secondary Population Research</b>	<b>96</b>
	4



<b>Approach</b>	<b>96</b>
<b>Social Vulnerability Index</b>	<b>97</b>
<b>Social Determinants of Health</b>	<b>99</b>
Economic Stability	100
Neighborhood & Physical Environment	106
Education	122
Food Access	130
Community & Social Context	136
<b>Healthcare System</b>	<b>150</b>
Uninsured Population	150
Underinsured Population	154
Healthcare Facility Profile	157
Healthcare Workforce	159
<b>Health Status, Chronic Disease, &amp; Outcomes</b>	<b>170</b>
Leading Causes of Death & Mortality Rates	170
Chronic Disease	174
Cancer	177
Preventative Care	179
Sexual Health	181
Maternal Health	184
Behavioral Risk Factors	189
<b>Behavioral Health</b>	<b>191</b>
Mental Health of Older Adults	194
Youth Behavioral Health	195
Substance Use	197
Behavioral Health Workforce	206
Behavioral Health Facilities	208
The Opioid Epidemic	211

LGBTQIA + Youth	213
<b>Appendices</b>	<b>216</b>
<b>Appendix A: Carson Tahoe Health IRS Form 990, Schedule H</b>	<b>217</b>
<b>Appendix B: Carson Tahoe Health Progress Since 2019 CHNA</b>	<b>218</b>
<b>Appendix C: Secondary Population Data Sources</b>	<b>229</b>
<b>Appendix D: Stakeholder Interview Guide</b>	<b>234</b>
<b>Appendix E: Focus Group Discussion Moderator’s Guide</b>	<b>239</b>
<b>Appendix F: Telephone Survey Templates</b>	<b>245</b>
<b>Appendix G: Community Survey Templates</b>	<b>249</b>
<b>Appendix H: Access Audit</b>	<b>260</b>
<b>Appendix I: Additional Community Survey Prioritization Tables</b>	<b>263</b>
Prioritized Needs by CTH PSA and County	263
Prioritized Needs by Age	273
Prioritized Needs – Less than \$55,000 vs. \$55,000 or more	279
<b>: Additional Needs Prioritization Process and Results</b>	<b>284</b>
<b>Appendix K: Community Resource Guide</b>	<b>290</b>

# Introduction: Quad-County Regional Community Health Needs Assessment

## Purpose

This Quad-County Community Health Needs Assessment (CHNA) serves as a critical phase in the overall effort to improve community health and reduce health disparities. The CHNA process provides a means of collecting community health status and behaviors, identifying community health needs, and engaging community members to improve the well-being of the community. The resulting document creates a frame of reference for community members to discuss the health status of a population. The purpose of this CHNA process and report has been to identify health issues, identify and engage local collaborators and assets, and prioritize the implementation activities needed to address the identified issues.

This assessment is the result of a collaborative planning effort between eight agencies: Carson Tahoe Health, Carson City Health & Human Services, Nevada Association of Counties, Community Chest, Inc., Lyon County Human Services, Partnership Douglas County, and Douglas County Community Services.

Carson Tahoe Health (CTH), a Nevada nonprofit corporation, and its subsidiaries, Carson Tahoe Regional Healthcare (CTRH), a Nevada nonprofit corporation doing business as Carson Tahoe Regional Medical Center (CTRMC), and Carson Tahoe Continuing Care Hospital, Inc. (CTCCH) contracted Crescendo Consulting Group (CCG) to conduct this survey of the Carson Tahoe Health Primary Service Area and the Quad-County communities. Carson Tahoe Health will develop a hospital specific Implementation Strategy based on this CHNA.

At a minimum Carson City Health & Human Services conducts a CHNA every 5 years which is a necessary component for Public Health Accreditation that was obtained in May 2016. Next steps are updating the Community Health Improvement Plan and a Health Department Specific Strategic Plan based on this CHNA.

## Importance of the Collaborative Approach

Collaboration is a key operating principle across the Quad-County Region. Many local non-profits and organizations recognize the importance of collaboration, or working together to achieve a common purpose, and view it as a strength of the Quad-County Region. To better understand the needs of the community and deepen cooperation among agencies with the ability to impact the most pressing needs, a coalition of like-minded community partners joined the effort to complete the 2022 Community Health Needs Assessment.

**Effective collaborative partnerships include objectives such as the following:**

- **Create a vision that is broadly understood**

- **Work across organizational boundaries**

- **Include those most affected by health challenges in solution-creation**

- **Utilize ongoing planning and joint accountability to measure change**

## Quad-County Planning Partners

The number and the quality of partner engagement involved is a key measure of an effective collaborative. The Quad-County Region partnership includes various community care positions, public health departments, community-based organizations, and others. The planning committee included leaders and stakeholders from the following agencies:

**Carson Tahoe Health**

**Carson City Health & Human Services**

**Lyon County Human Services**

**Nevada Association of Counties**

**Community Chest, Inc.**

**Partnership Douglas County**

**Douglas County Community Services**

**Quad-County Public Health Preparedness**

## Equity Champions

Equity Champions were recruited to join the planning coalition and paid a stipend to advise on the CHNA process, research instruments, and communities surveyed. They provided additional insight and facilitated connections into medically underserved populations in the community. Additionally, Equity Champions reviewed research tools for cultural competency and inclusion. Five equity champions each brought personal and/or extensive work experience related to the following populations in the Quad-County Region: LGBTQ+ individuals, Hispanic/Latino individuals, individuals in poverty and with food insecurity, individuals with severe mental illness, and peers and families of individuals with mental health and substance abuse challenges.

## CHNA Methodology

The Quad-County CHNA Planning Committee worked with its assessment partner Crescendo Consulting Group to formalize and deploy a highly inclusive assessment framework. At the conclusion of the process, the Quad-County Region developed a succinct, prioritized list of community needs. To do this, the methodology included a mixed modality approach – quantitative, qualitative, and technology-based techniques – to learn about the human stories and voices while weaving them with the best available data. Crescendo engaged community partners, used data analytics, and invited others to join the discovery process to help create a positive cycle of change. The assessment activities met the following goals:

- Identify community resources, strengths, and barriers.
- Develop a deeper understanding of community access to care challenges, including those faced by groups historically underserved by healthcare facilities and programs.
- Enable partners to coalesce around, and act upon, the opportunities for population health improvement.

The following illustrates the three-stage approach used to support the project goals.

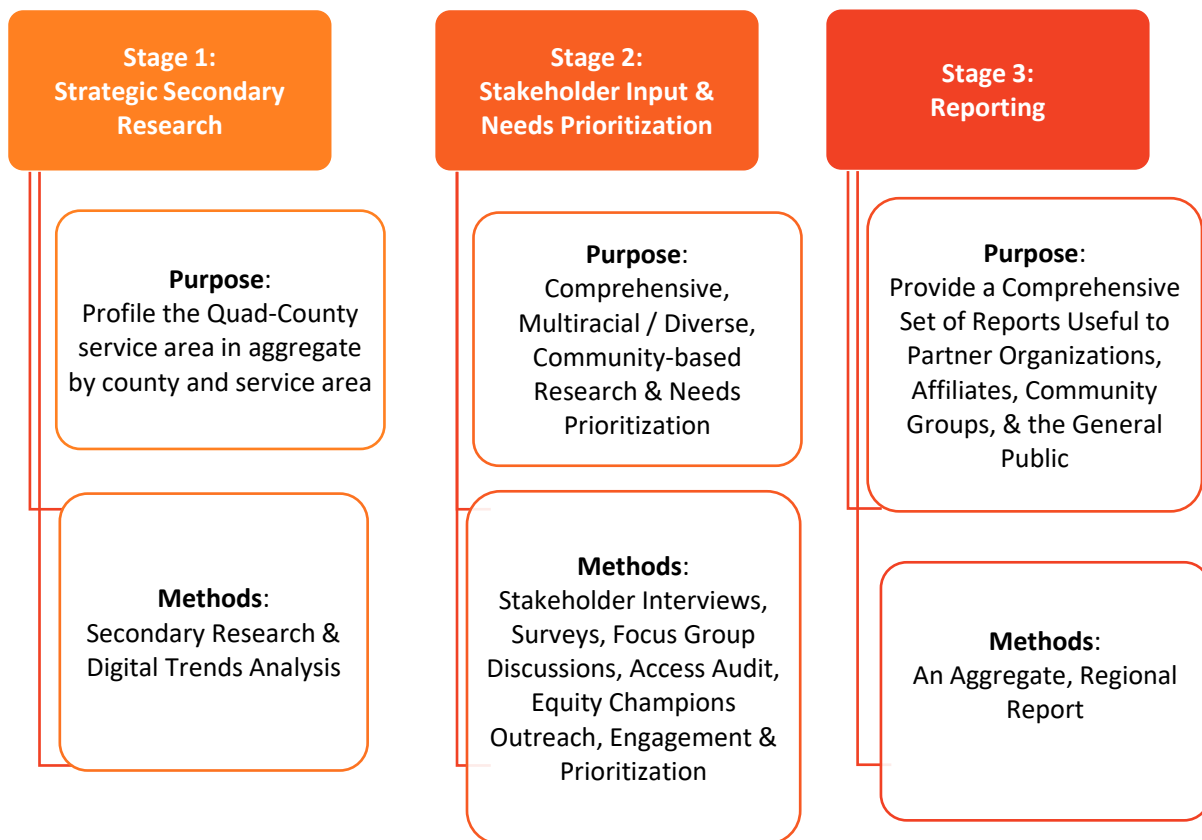

## Operational Framework

The image illustrates how the mixed modality research methodology used stakeholder interviews, focus group discussions, a large sample community survey, and an access audit to ensure community voices were amplified and included in the prioritization process.

Based on the results of the mixed-modality approach, an extensive list of approximately 40 community needs were identified for the Quad-County Region.

This CHNA deployed a “*Modified Delphi Technique*” to prioritize the needs.

Each technique deployed in the CHNA was part of the longer-term Assessment as Action Cycle which jump-starts the continuous process of assessing community needs, addressing high-priority needs, evaluating impact, adjusting strategies, and assessing community needs.

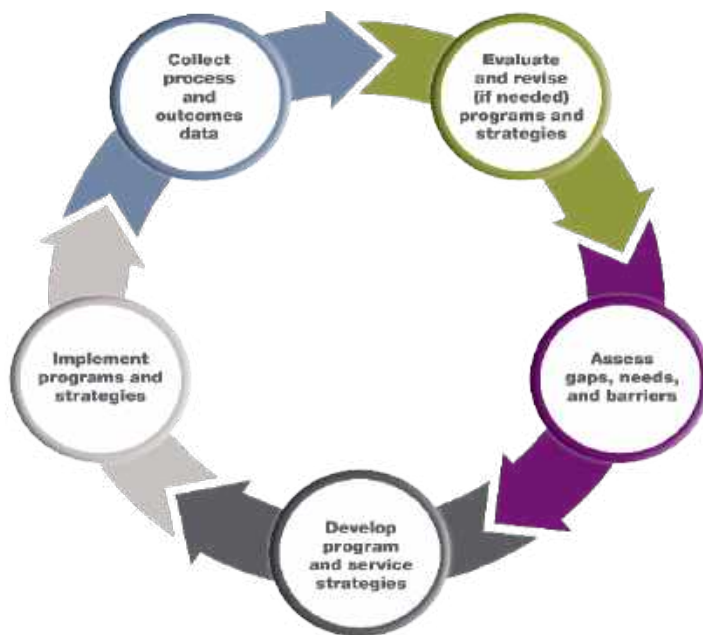
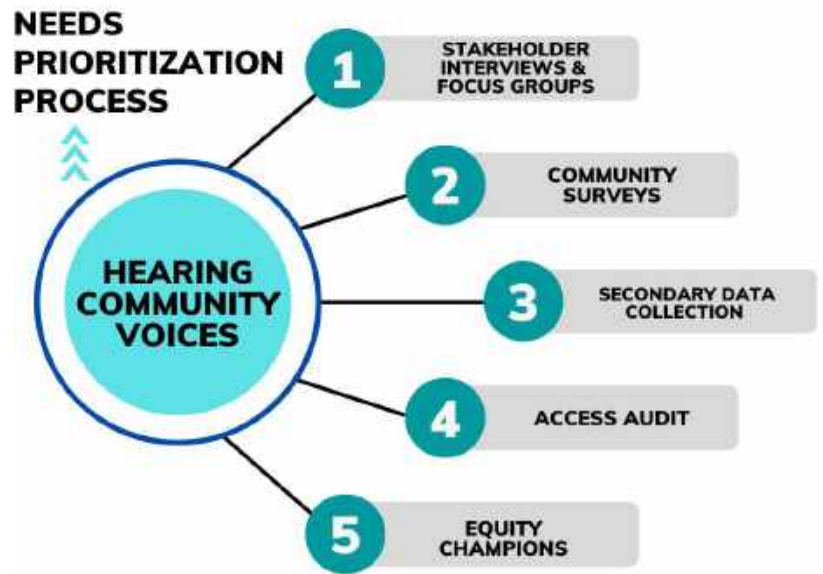

The CHNA provided an important opportunity for all the stakeholders in this complex landscape to work together to build a positive cycle of change. The ongoing cycle of assessment, strategy development, program development, program implementation, data collection, and program evaluation are a proven way to continually improve community health.



## Community Description & Population Demographics

The community defined for this assessment is delineated by Carson Tahoe Health’s Primary Service Area ZIP codes (referred to as CTH PSA in this report) and by Carson City, Douglas, Lyon, and Storey Counties, collectively known as the Quad-County Region.

The Carson Tahoe Health Primary Service Area encompasses the ZIP codes in which 75.0% of Carson Tahoe Regional Healthcare (CTRH), Carson Tahoe Regional Medical Center (CTRMC), and Carson Tahoe Continuing Care Hospital (CTCCH) (collectively, Carson Tahoe Health) patients live, illustrated in the following map. All named facilities (CTRH, CTRMC, CTCCH) use the same definition of community.

**Exhibit 1: Carson Tahoe Health’s Primary Service Area (CTH PSA)**

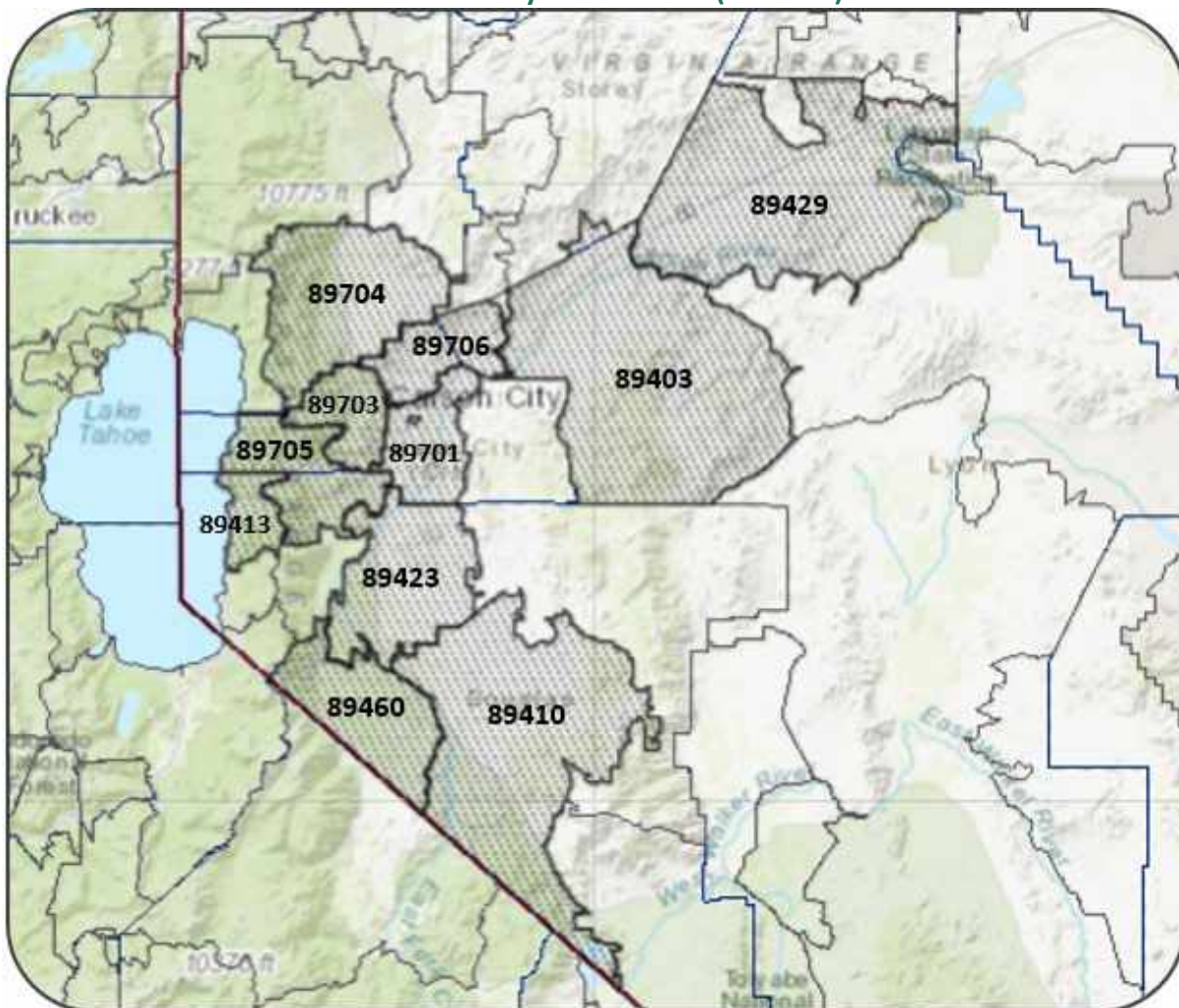

Source: UDS Mapper<sup>1</sup>

<sup>1</sup> UDS Mapper. Carson Tahoe Health Primary Service Area. Link: [https://maps.udsmapper.org/map?map\\_id=QvD2XVqleQvrzmjANnbk](https://maps.udsmapper.org/map?map_id=QvD2XVqleQvrzmjANnbk)



## QUAD-COUNTY REGIONAL COMMUNITY HEALTH NEEDS ASSESSMENT

Across all survey methods, insight and data were collected for Carson City, Douglas, Lyon, and Storey Counties, collectively referred to as the Quad-County Region.

### Exhibit 2: Quad-County Region



Source: <https://gethealthycarsoncity.org/novel-coronavirus-2019/>

Source: [gisgeography.com](https://gisgeography.com) modified by CTH

The total population of the Quad-County Region is expected to expand rapidly over the next decade. The population in Nevada is projected to grow from 3,173,326 in 2021 to 3,469,124 in 2031 (9.3%).

**Exhibit 3: Quad-County Region Projected Populations**

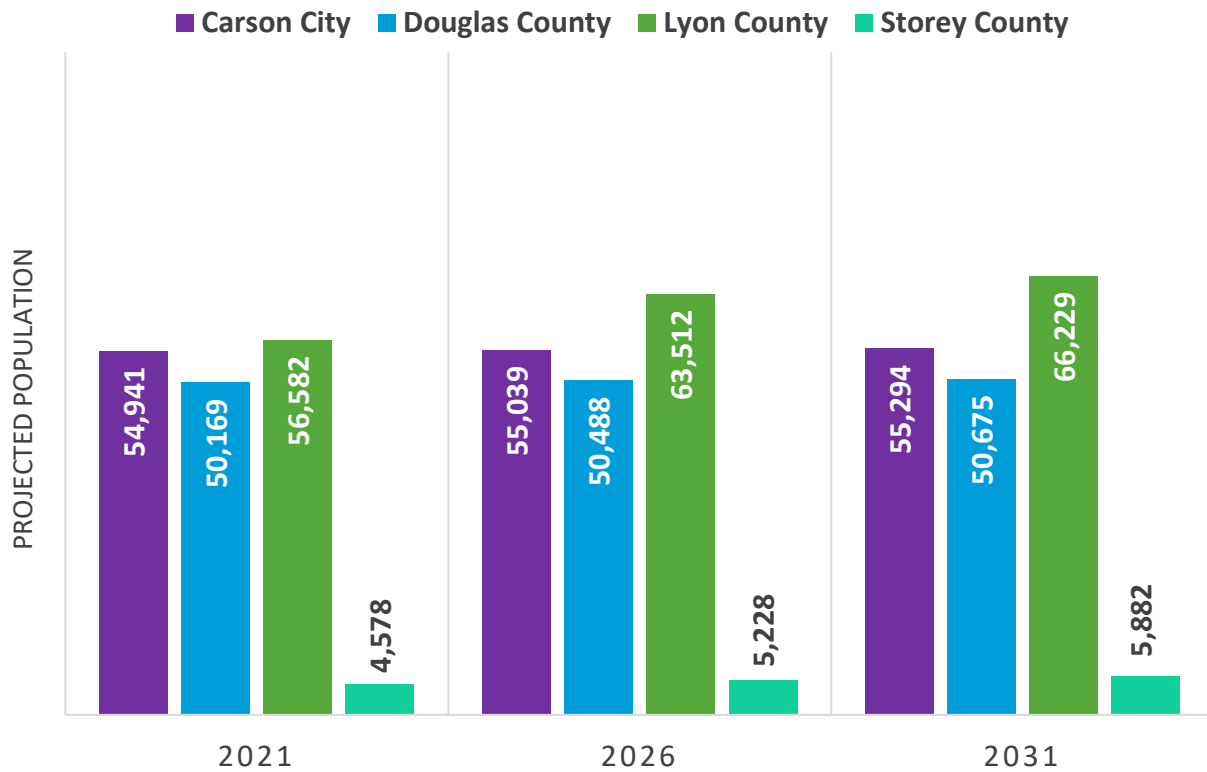

	Nevada	Carson City	Douglas County	Lyon County	Storey County
2031	3,469,124	55,294	50,675	66,229	5,882
2026	3,360,737	55,039	50,488	63,512	5,228
2021	3,173,326	54,941	50,169	56,582	4,578

Source: University of Nevada, Reno School of Medicine’s Office of Statewide Initiatives, Nevada Instant Atlas. Nevada Rural & Frontier Health Data Book, 2021

**Exhibit 4: Projected Population Change**

2021 TO 2031	Nevada	Carson City	Douglas County	Lyon County	Storey County
Projected % Change	9.3%	0.6%	1.0%	17.0%	28.5%

Source: University of Nevada, Reno School of Medicine’s Office of Statewide Initiatives, Nevada Instant Atlas. Nevada Rural & Frontier Health Data Book, 2021

The median age within the Carson Tahoe Health Primary Service Area (CTH PSA) is at least eight years older compared to Nevada as well as Carson City (42.2), and Lyon County (43.9). Storey

County presents the highest median age at 53 years old.

**Exhibit 5: Population by Select Age Groups**

	United States	Nevada	CTH PSA	Carson City	Douglas County	Lyon County	Storey County
<b>Total Population</b>	326,569,308	3,030,281	126,246	55,244	48,486	55,667	4,086
Median Age	38.2	38.2	46.9	42.2	52.9	43.9	53.0
Under 5	6.0%	6.1%	4.7%	5.5%	3.4%	5.2%	4.2%
5 to 9	6.1%	6.2%	5.3%	5.5%	5.0%	6.4%	5.6%
10 to 14	6.5%	6.6%	5.2%	5.9%	4.6%	5.7%	4.4%
15 to 19	6.5%	6.0%	5.2%	5.4%	5.2%	5.9%	6.5%
20 to 24	6.7%	6.0%	5.0%	5.6%	4.1%	4.4%	4.6%
25 to 34	13.9%	14.6%	11.6%	13.0%	9.6%	12.3%	5.5%
35 to 44	12.7%	13.3%	10.8%	11.7%	9.8%	11.9%	11.4%
45 to 54	12.7%	13.0%	12.0%	12.4%	11.3%	12.2%	11.7%
55 to 59	6.7%	6.5%	8.4%	7.4%	8.7%	7.3%	7.2%
60 to 64	6.2%	5.9%	8.2%	7.3%	9.7%	7.5%	7.3%
65 and Older	16.0%	15.8%	23.6%	20.3%	28.5%	21.2%	31.6%

Source: U.S. Census Bureau, 2016-2020 American Community Survey Five-Year Estimates

**Exhibit 6: Median Age**

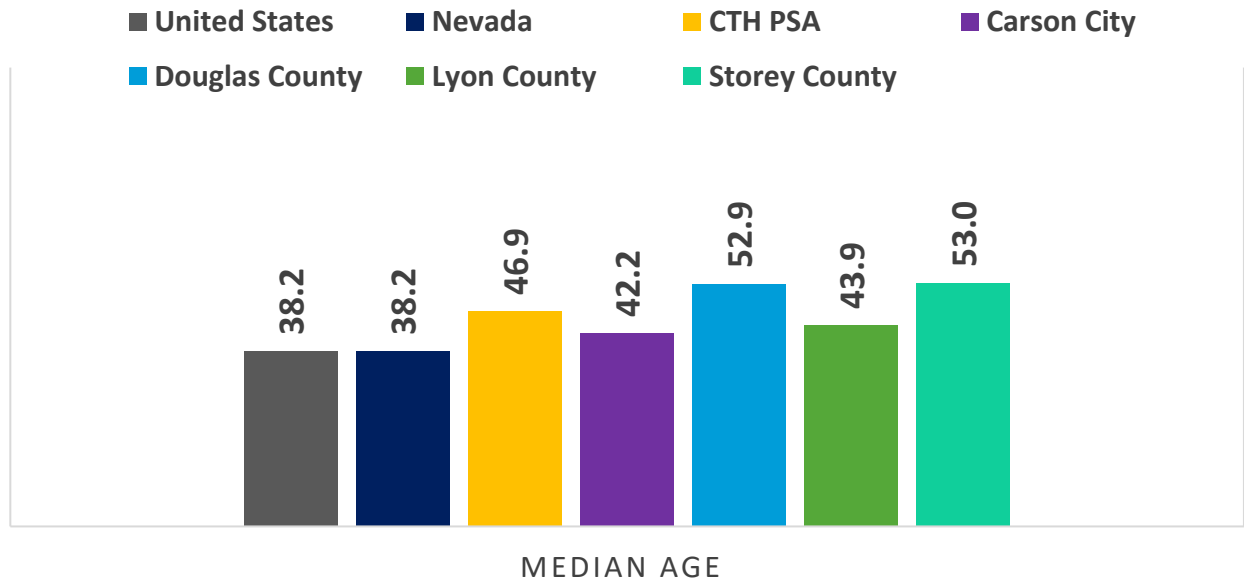

Source: U.S. Census Bureau, 2016-2020 American Community Survey Five-Year Estimates

The population of older adults in the Quad-County Region has been steadily increasing since 2016 and is expected to grow by 2026. The population 65 and older within the Quad-County Region is greater compared to the population under 18, and between the ages of 18 and 64.<sup>2</sup>

In 2021, Douglas and Storey County had the highest percentage of older adults aged 65 and older within the Quad-County Region (28.8%, 30.5%, respectively).

**Exhibit 7: Projected Population of Older Adults**

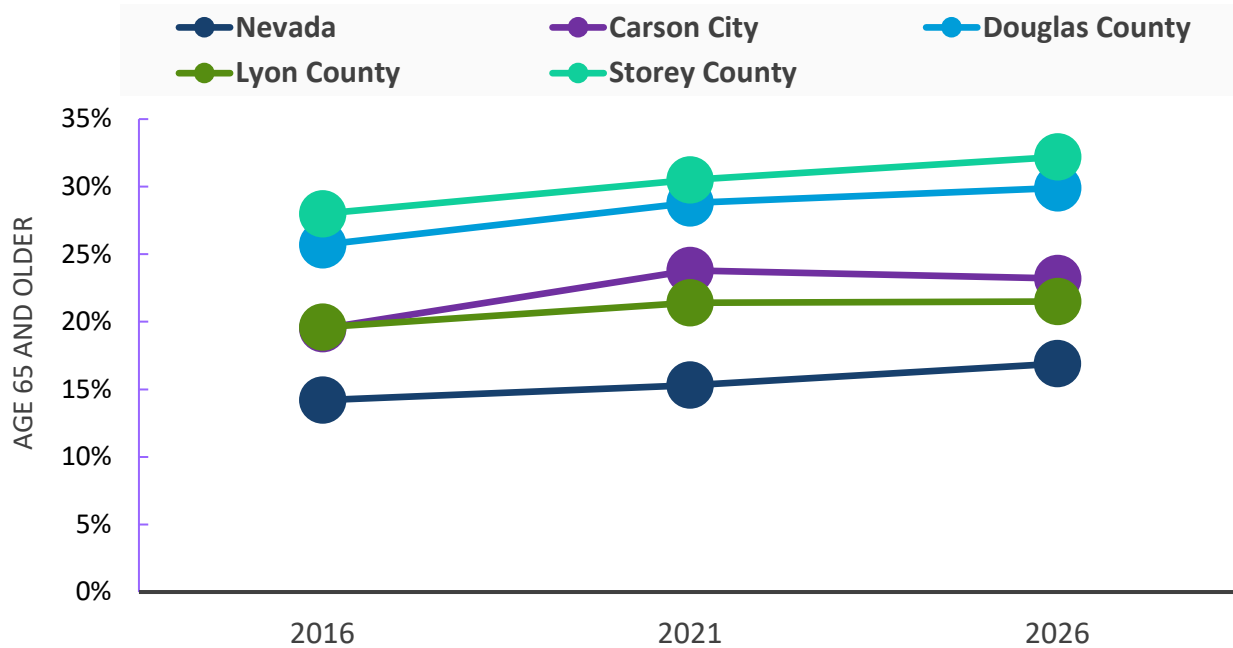

AGE 65 AND OLDER	Nevada	Carson City	Douglas County	Lyon County	Storey County
2026	16.9%	23.2%	29.9%	21.5%	32.2%
2021	15.3%	23.8%	28.8%	21.4%	30.5%
2016	14.2%	19.5%	25.7%	19.6%	28.0%

Source: University of Nevada, Reno School of Medicine’s Office of Statewide Initiatives, Nevada Instant Atlas. Nevada State Demographer’s Office

<sup>2</sup> University of Nevada Reno School of Medicine Office of Statewide Initiatives. Nevada Rural & Frontier Health Data Book, 2021.

The Carson Tahoe Primary Service Area (CTH PSA) is primarily comprised of residents who identify as White (83.5%), similar to each service area county. Lyon County has the highest percentage of those who identify as American Indian and Alaskan Native (3.1%). Lyon County is home to the Yerington Reservation and Trust Lands, Walker River Indian Reservation, and Pyramid Lake Indian Reservation.

**Exhibit 8: Population by Race**

Population by Race	United States	Nevada	CTH PSA	Carson City	Douglas County	Lyon County	Storey County
White	70.4%	62.1%	83.5%	79.5%	87.0%	81.4%	77.6%
Black or African American	12.6%	9.3%	1.1%	2.3%	0.7%	1.3%	1.3%
American Indian and Alaska Native	0.8%	1.2%	2.0%	2.6%	1.6%	3.1%	1.2%
Asian	5.6%	8.3%	2.1%	3.5%	1.9%	1.6%	6.7%
Native Hawaiian and Other Pacific Islander	0.2%	0.7%	0.2%	0.1%	0.2%	0.1%	0.8%
Some other race	5.1%	10.8%	6.1%	7.2%	4.1%	6.5%	5.3%
Two or more races	5.2%	7.5%	5.1%	4.8%	4.6%	5.9%	7.2%

Source: U.S. Census Bureau, 2016-2020 American Community Survey Five-Year Estimates

**Exhibit 9: Population by Ethnicity**

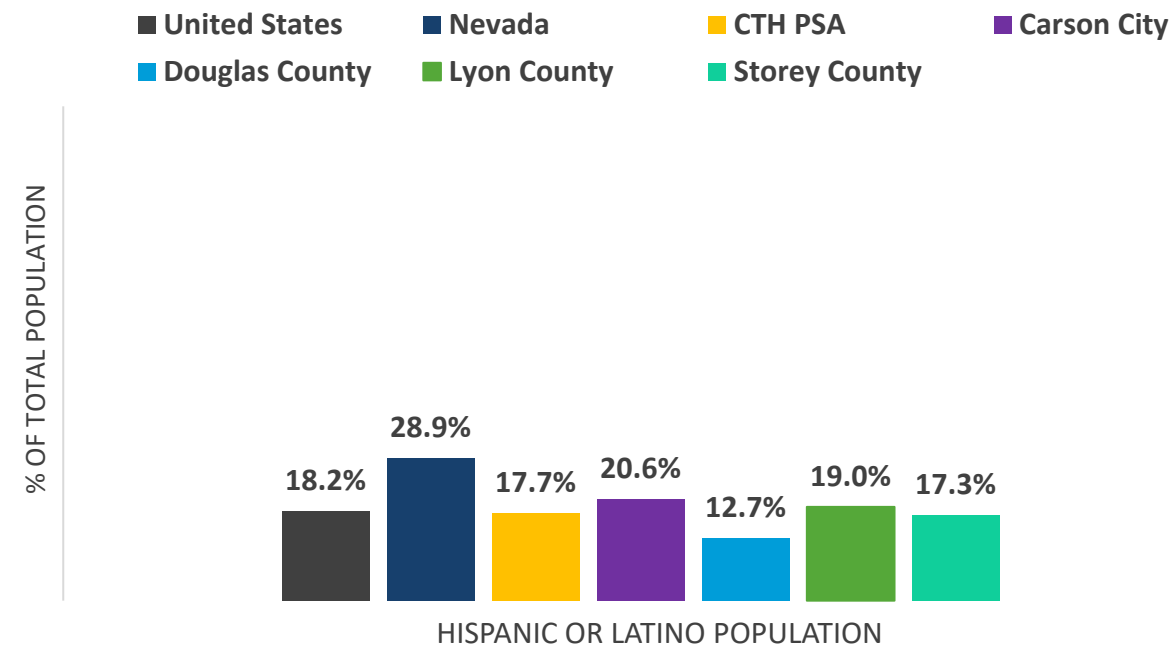

QUAD-COUNTY REGIONAL COMMUNITY HEALTH NEEDS ASSESSMENT

	United States	Nevada	CTH PSA	Carson City	Douglas County	Lyon County	Storey County
<b>Hispanic or Latino</b>	18.2%	28.9%	17.7%	20.6%	12.7%	19.0%	17.3%
Mexican	11.2%	21.7%	14.4%	17.5%	10.3%	14.8%	13.1%
Puerto Rican	1.7%	0.9%	0.4%	0.1%	0.6%	0.3%	0.3%
Cuban	0.7%	1.2%	0.3%	0.1%	0.1%	0.3%	0.5%
Other Hispanic or Latino	4.5%	5.1%	2.7%	2.8%	1.7%	3.6%	3.4%
<b>Not Hispanic or Latino</b>	81.8%	71.1%	82.3%	79.4%	87.3%	81.0%	82.7%

Source: U.S. Census Bureau, 2016-2020 American Community Survey Five-Year Estimates

The percentage of residents who identify as Hispanic or Latino in the Quad-County Region is lower than the statewide population percentage (28.9%). Between 2021 and 2031, the Hispanic population in Nevada is projected to increase by 205,794 (21.1%), more than twice the overall population (21.1% 9.3%, respectively).<sup>3</sup>

**Exhibit 10: Hispanic or Latino Population Percent Changed<sup>4</sup>**

	United States	Nevada	Carson City	Douglas County	Lyon County	Storey County
<b>2010 to 2020</b>	+23.0%	+24.3%	+26.3%	+20.3%	+34.7%	+49.1%
<b>Total Population Change</b>	+11,602,450	+173,756	+3,093	+1,038	+2,665	+112

Source: U.S. Census Bureau. Racial & Ethnic Diversity in the United States: 2010 Census & 2020 Census

<sup>3</sup> University of Nevada Reno School of Medicine Office of Statewide Initiatives. Nevada Rural & Frontier Health Data Book, 2021. Link: [med.unr.edu/statewide/reports-and-publications/nevada-rural-and-frontier-health-data-book](http://med.unr.edu/statewide/reports-and-publications/nevada-rural-and-frontier-health-data-book)

<sup>4</sup> Data for the Carson Tahoe Health service area were based on aggregated data available at the ZIP Code level. For some measures, ZIP Code data was not available, so some CTH data points are omitted.

## Diversity Index

The Quad-County Region is becoming a more diverse community over time. The Diversity Index (DI) measures the probability or chance that two people chosen at random will identify as a different race and ethnic group by county. Probabilities have been converted into percentages for easier interpretations. Storey County’s DI score increased 10.7%, indicating the largest increase in diversity, followed by Lyon, Carson City, and Douglas County.

**Exhibit 12: Diversity Index Ten-Year Comparison**

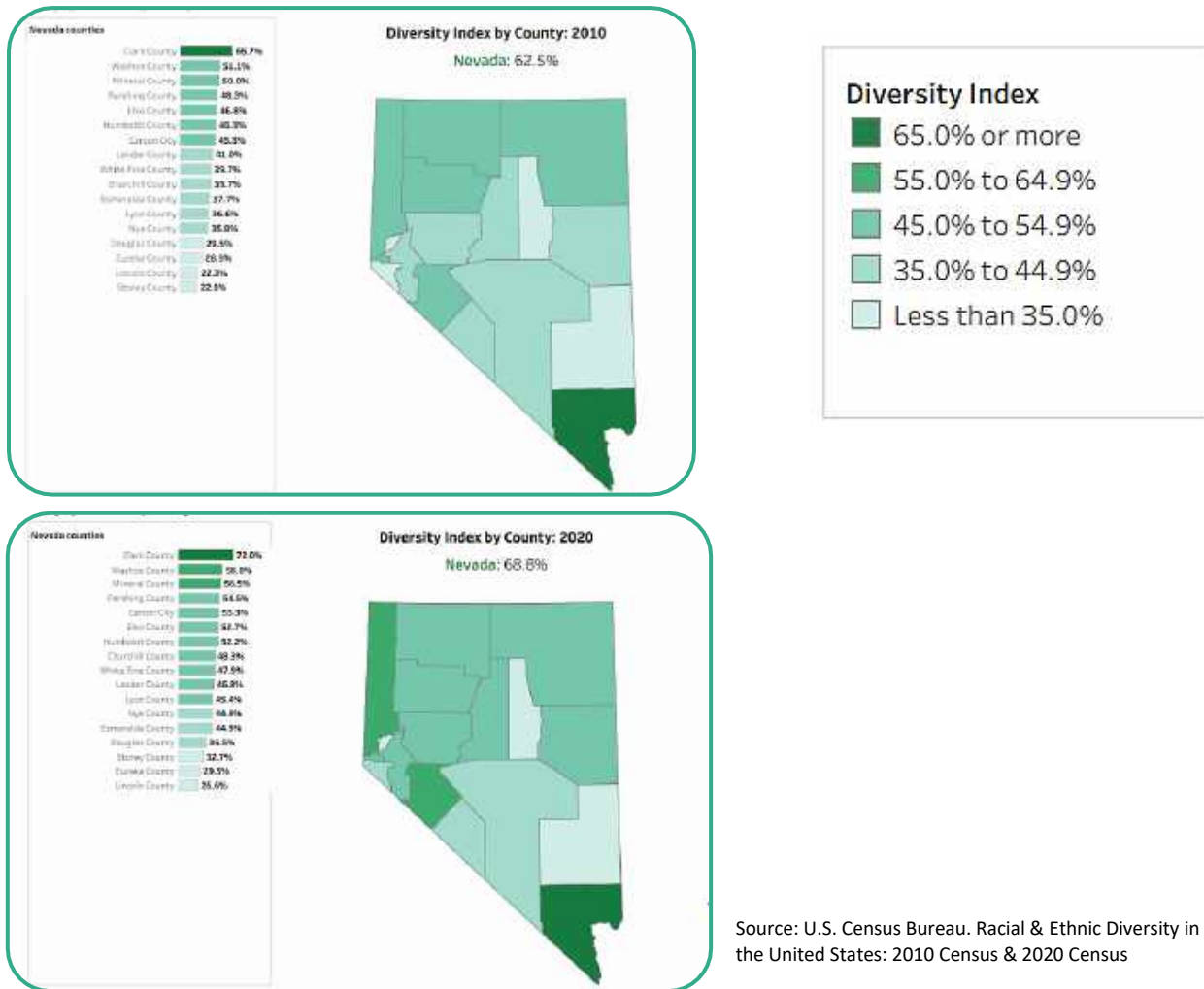

Source: U.S. Census Bureau. Racial & Ethnic Diversity in the United States: 2010 Census & 2020 Census

**Exhibit 13: Diversity Index Scores**

	United States	Nevada	Carson City	Douglas County	Lyon County	Storey County
2020	61.1%	68.8%	45.9%	36.5%	45.4%	32.7%
2010	54.9%	62.5%	37.2%	29.5%	36.6%	22.0%

Source: U.S. Census Bureau. Racial & Ethnic Diversity in the United States: 2010 Census & 2020 Census

**Exhibit 1: Population World Region of Births**

	United States	Nevada	CTH PSA	Carson City	Douglas County	Lyon County	Storey County
<b>Foreign-born</b>	13.5%	19.4%	9.4%	12.8%	6.9%	6.7%	5.1%
Europe	10.8%	7.4%	1.2%	9.6%	21.5%	6.4%	14.4%
Asia	31.3%	31.4%	1.5%	14.2%	19.5%	14.8%	40.4%
Africa	5.4%	3.7%	0.2%	3.1%	0.6%	0.1%	0.0%
Oceania	0.6%	0.6%	0.0%	0.2%	0.5%	0.0%	0.0%
Latin America	50.0%	55.0%	6.0%	69.0%	48.6%	76.1%	5.3%
Northern America	1.9%	1.9%	0.5%	3.9%	9.3%	2.6%	39.9%

Source: U.S. Census Bureau, 2016-2020 American Community Survey Five-Year Estimates

- Over three-quarters (76.1%) of the foreign-born residents in Lyon County were born in Latin America. Carson City also has a high population that was born in Latin America at 69.0%, both of which are higher than the state and national percentages.
- Nearly half of the Douglas County foreign-born population was born in Latin America (48.6%), a lower percentage than any county besides Storey County (5.3%).
- There is a high percentage of individuals in Storey County that were born in Asia (40.4%). Approximately 19.5% of the foreign born population in Douglas County was born in Asia, with a similar percentage born in Europe (21.5%).



## Population Living with a Disability

In comparison to those living without a disability, people with disabilities have less access to healthcare, experience more depression and anxiety, engage more often in risky health behaviors such as smoking, and are less physically active.<sup>5</sup>

Within the Carson Tahoe Primary Service Area, 16.2% of the population is living with a type of disability, a percentage higher than the statewide figure (12.5%). The CTH PSA, among the delineated service areas, has the highest population of children aged five to 17 living with a disability (9.1%).

Exhibit 15: People Living with a Disability Profile<sup>6</sup>

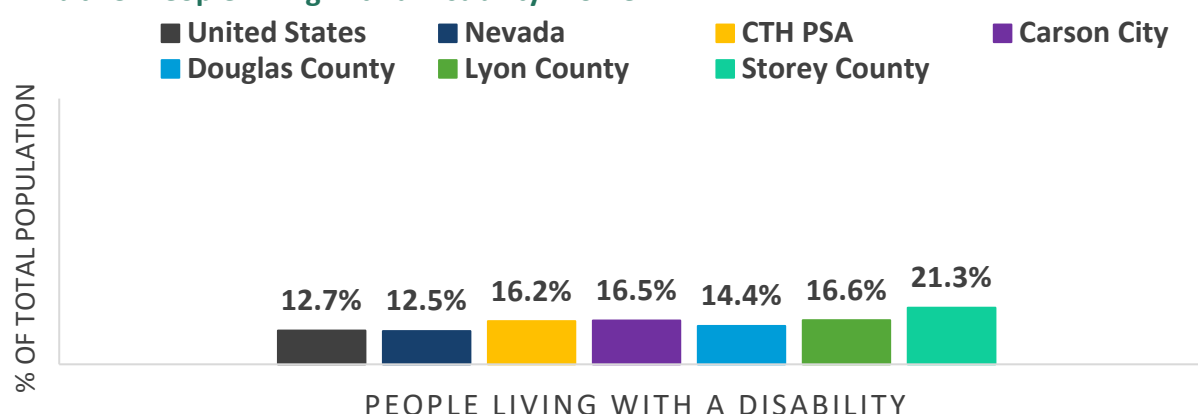

	United States	Nevada	CTH PSA	Carson City	Douglas County	Lyon County	Storey County
<b>Total Population</b>	326,569,308	3,030,281	126,246	55,244	48,486	55,667	4,086
% of Population LWD <sup>7</sup>	12.7%	12.5%	16.2%	16.5%	14.4%	16.6%	21.3%
Male	12.5%	12.6%	16.5%	15.9%	14.9%	17.8%	28.7%
Female	12.8%	12.5%	15.8%	17.1%	13.8%	15.4%	13.4%
<b>Age</b>							
Under 5	0.7%	1.1%	3.0%	3.9%	0.0%	0.0%	0.0%
5 to 17	5.7%	5.1%	9.1%	7.0%	3.6%	7.8%	0.0%
18 to 34	6.6%	6.2%	12.6%	12.5%	4.3%	7.1%	15.2%
35 to 64	12.5%	12.4%	18.4%	13.3%	10.4%	16.2%	14.4%
65 to 74	24.4%	25.5%	32.9%	28.0%	23.7%	31.8%	35.7%

<sup>5</sup> Centers for Disease Control & Prevention. Health Equity for People with Disabilities, 2021.

Link: [cdc.gov/ncbddd/humandevelopment/health-equity.htm](https://cdc.gov/ncbddd/humandevelopment/health-equity.htm)

<sup>6</sup> Civilian noninstitutionalized population.

<sup>7</sup> LWD = Living with Disability

## QUAD-COUNTY REGIONAL COMMUNITY HEALTH NEEDS ASSESSMENT

	United States	Nevada	CTH PSA	Carson City	Douglas County	Lyon County	Storey County
75 and over	48.1%	48.2%	59.8%	50.3%	44.2%	44.9%	55.1%

Source: U.S. Census Bureau, 2016-2020 American Community Survey Five-Year Estimates

- Approximately three in five people aged 75 and older in the CTH PSA (59.8%) live with a disability. Among the counties, Storey County has the highest percentages of individuals aged 65 and older living with a disability.
- More than one in five people in Storey County (21.3%) is living with a disability. This figure is further supported by the high percentage of older adults in the area – more than thirty percent of the population is age 65 and older.

Approximately 11.2% of residents in the CTH PSA live with an ambulatory difficulty, defined as having serious difficulty walking or climbing stairs, more than any other disability. The percentages of individuals living with a disability in the PSA are higher than state and national averages in every category. Among the four counties, Storey County presents with the highest percentages of residents living with any type of disability.

### Exhibit 16: People Living with a Disability by Difficulty

	United States	Nevada	CTH PSA	Carson City	Douglas County	Lyon County	Storey County
Hearing Difficulty	3.6%	3.8%	8.8%	7.0%	6.1%	5.5%	9.0%
Vision Difficulty	2.4%	2.7%	4.9%	4.4%	2.7%	3.2%	6.0%
Cognitive Difficulty	5.1%	4.6%	7.3%	6.3%	4.5%	6.4%	10.3%
Ambulatory Difficulty	6.8%	7.0%	11.2%	9.0%	7.5%	9.6%	14.5%
Self-Care Difficulty	2.6%	2.5%	4.4%	3.7%	2.5%	4.4%	7.3%
Independent Living Difficulty	5.8%	5.3%	6.9%	6.4%	4.6%	7.5%	9.2%

Source: U.S. Census Bureau, 2016-2020 American Community Survey Five-Year Estimates

### Exhibit 17: Percentage of People in CTH PSA Living with a Disability, by Disability Type

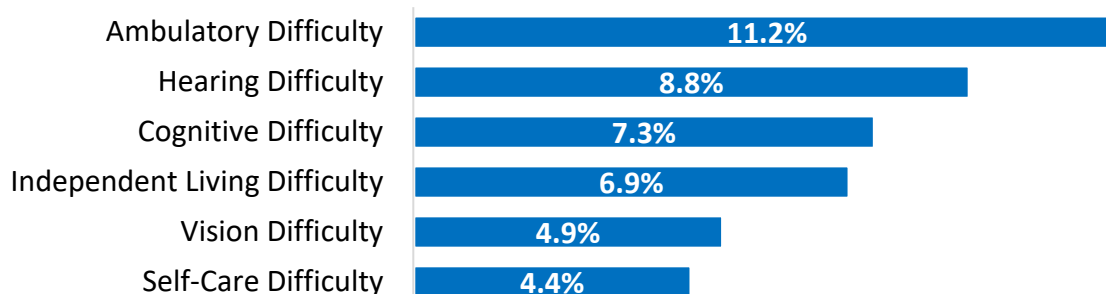

## Prioritization Process and Results

### Needs Prioritization Process

The Needs Prioritization Process brought together the summary of results from secondary research data, qualitative research themes, and the community and telephone survey.

A detailed list of 43 needs were identified for the Quad-County Region. Each of the needs in the prioritization process directly links to data observations and/or qualitative feedback. The resulting list of needs represents the items participants were asked to evaluate in the Prioritization Process. (For full list see Appendix J).

The Leadership Group utilized a modified Delphi Method to construct a prioritized list of needs for the region. The three-round approach described for the participants in advance included:

- **Round 1:** The first step asked participants to evaluate and comment on each need in a provided list via an online survey derived from primary and secondary research.
- **Round 2:** The second step asked participants to evaluate the same list of needs, but this list showed their colleagues' deidentified comments. The purpose of this process is to provide participants with additional insight as they evaluate each need.
- **Round 3:** The third step was an in-person meeting of the Leadership Group to discuss the results of the first two steps of the Prioritization Process along with any other observations that may have been missed along the way. The group utilized a score metric that measured community partnership and feasibility, resources and capacity, and timeline. The group also compared and discussed the rankings of each need in the community survey relative to the prioritization survey and discussed disparities across each of the counties and the CTH Primary Service Area. The individual needs were also grouped to weigh the relative acuity of broad, high-level domains of need.

The resulting data was analyzed from a variety of perspectives, with each of the metrics (i.e. feasibility, resources, community perspective from survey, variance between counties, etc.) prioritized in turn to understand where there was commonality across modes of analysis. From this analysis, the Leadership Group determined the **four domains of need shown below** as the top priority health needs for the Quad-County region. The prioritized needs listed within each domain were selected based on the ranking process described above, which includes perceived severity of need by community members and Leadership Group, as well as disease prevalence and mortality data from the secondary population research.

## Prioritized Community Need Domains & Needs

### Access to Basic Needs

- Access to Primary Care, including for Low-Income & Underinsured Individuals
- Availability and Affordability of Childcare
- Availability and Affordability of Housing, including supportive and transitional housing for individuals in need of wrap-around services
- Prescription Affordability and Access
- Access to internet and broadband
- Access to physical and social activities for youth

### Access to Healthcare for Specific Populations

- Access to Specialty Care
- Home Health Care across region
- Increased case management, treatment, and care coordination for people with complex chronic health problems such as diabetes
- Prevention and Treatment for Cardiovascular Disease, Kidney Disease, and Cancer
- Care for individuals with dementia/memory care needs
- Care for youth and adults with developmental disabilities
- Competency of providers to serve specific populations, including knowledge of LGBTQ+ needs and increasing Spanish-speaking providers
- Transportation to medical appointments

### Mental and Emotional Health

- Providers for both youth and adults including Peer Support Specialists, Community Health Workers, Clinical Professional Counselors, Licensed Clinical Social Workers, and Psychiatrists.
- Resource capacity across range of acuity:
  - Screening & Assessments
  - Outpatient services, including Intensive Outpatient Services
  - Inpatient services
  - Crisis care
- Programs/activities to reduce social isolation, increase support, and promote mental and emotional health

### Substance Use Prevention, Treatment, & Recovery

- Need capacity across range of acuity:
  - Drug and other substance use prevention and early intervention programs
  - Drug and other substance use treatment services, including Intensive Outpatient Services, Groups, and community-based treatments.
  - Programs and services to support individuals in recovery
- For youth, increased coordination between school systems and community providers and agencies to address prevention and early intervention

## Summary of Findings

The Community Health Needs Assessment utilized an inclusive quantitative and qualitative research approach to understand the community needs in the Quad-County Region. In addition to analyzing a plethora of secondary data measures using the Social Determinants of Health framework, the Community Health Needs Assessment engaged the community to participate in the process through:

- 46 stakeholder interviews
- 15 focus groups with over 125 participants total
- 1,551 community survey respondents
- 400 random digit dialing telephone survey

The primary and secondary data was analyzed, and the following four categories were identified as the top community needs domains: (1) Access to Basic Needs; (2) Access to Healthcare for Specific Populations; (3) Mental and Emotional Health; (4) Substance Use Prevention, Treatment, and Recovery.

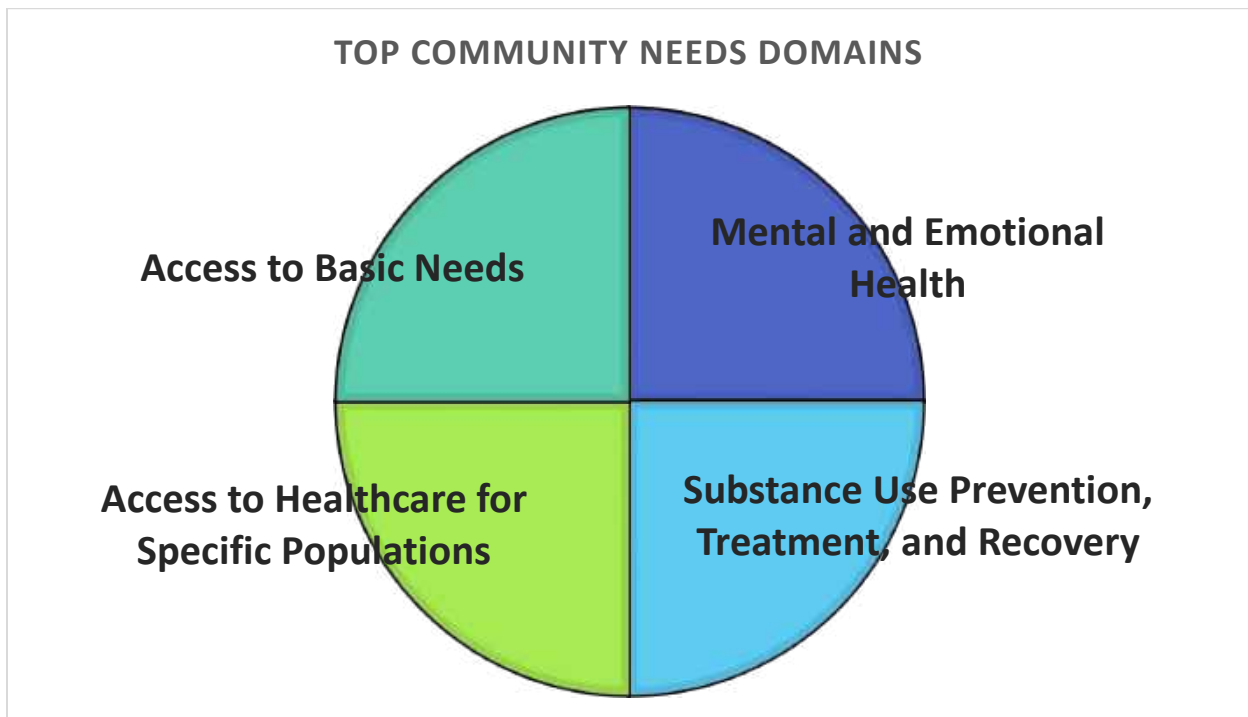

## Access to Basic Needs

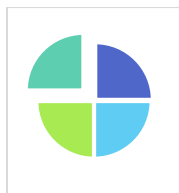

In 1943, Abraham Maslow introduced the world to his hierarchy of needs” theory<sup>8</sup>, which suggests that people are motivated to fulfill basic needs before moving on to other more advanced needs. Maslow’s Hierarchy of Needs is often portrayed as a pyramid with physiological needs, such as things that humans need to survive like food, water, shelter, and clothing, serving as the base. The second level is security and safety needs, such as health, employment, and resources.

The global COVID-19 pandemic over the past few years impacted virtually everyone on the planet, however, it has disproportionately impacted more vulnerable populations, including locally in the Quad-County Region. Many struggle to have their basic needs met, which impacts their ability to get and stay healthy. Some of the top community needs identified throughout the primary and secondary research include access to basic needs such as affordable housing, childcare, affordable and accessible prescriptions, and access to healthcare services for low-income individuals.

### Housing

The United States is currently in an affordable housing crisis that was brewing long before the COVID-19 pandemic, but escalated during the pandemic for a variety of reasons. According to the National Low Income Housing Coalition, there is a housing shortage of 7 million available and affordable rental units for extremely low-income renters, whose household incomes are at or below the federal poverty guidelines or 30% of their area median income<sup>9</sup>.

*“Rents are in the \$2,000 range and most of our clients live on less than \$900 a month. We’ve got motels that have transitioned to a monthly rate and people are paying \$900 a month to live in a facility with no kitchen or other amenities”.* - Focus Group Participant

Across the Quad-County Region, residents face a variety of housing challenges. Many stakeholders voiced challenges surrounding themes of affordable housing, housing stock, and a lack of resources for those experiencing housing insecurities. The lack of affordable housing is

<sup>8</sup> McLeod S. Maslow’s Hierarchy of Needs. <https://www.simplypsychology.org/maslow.html>

<sup>9</sup> National Low Income Housing Coalition. The Gap. <https://nlihc.org/gap>

affecting residents of all income levels for both home buying and rentals. Low-income housing is limited across the Carson Tahoe Health PSA and the Quad-County Region.

Many community residents identified the rising costs of rents and home prices as a top community need in the Quad-County Region. Cost-burdened households is a metric commonly used to identify potentially struggling households. Approximately one in three renter households in the Quad-County Region pay more than 35% of their household income in rent. Additionally, approximately one in three households with a mortgage are also cost-burdened, which is higher than the state and national percentage. Households that need to spend more on housing costs are less likely to be able to afford other necessities such as food, clothing, transportation, medical care, childcare, and more.

**Exhibit 28: Cost-burdened Households**

	United States	Nevada	CTH PSA	Carson City	Douglas County	Lyon County	Storey County
With a Mortgage	20.6%	23.0%	32.9%	30.9%	34.6%	29.2%	27.7%
Without a Mortgage	10.4%	8.7%	11.5%	10.2%	12.7%	11.2%	11.5%
Renter (35.0% or more)	40.0%	40.8%	33.1%	29.6%	36.9%	36.2%	32.9%

Source: U.S. Census Bureau, 2016-2020 American Community Survey Five-Year Estimates

**Childcare**

*“In general, we need more childcare facilities, there are only five places. They don't take many kids and it's very expensive. Many parents don't work because it only covers gas and childcare. When COVID hit, I had three kids in day care, and I paid \$1,700 every paycheck and I have a 50% discount due to my family owning the facility.” - Stakeholder*

The COVID-19 pandemic has put the childcare crisis in the national limelight over the past few years. The childcare industry has always been fragile and plagued with sustainability challenges from both the family and childcare provider sides, and COVID-19 restrictions only exacerbated the crisis. Childcare is often the biggest barrier for parents and caregivers, especially single moms, to entering and maintaining employment. In addition to limited capacity, the cost of childcare is expensive with the average family paying approximately \$10,174 a year in childcare costs<sup>10</sup>, which is approximately

<sup>10</sup> ChildCare Aware of America. Demanding Change. <https://info.childcareaware.org/hubfs/FINAL-Demanding%20Change%20Report-020322.pdf>

10% of the median income for a married couple and more than 35% of the median income for a single parent.

Affordable quality childcare was ranked as the fourth highest need in the community survey and ranked seventh in the telephone survey (see section “Quantitative Community Survey” for more rankings).

### Affordable and Accessible Prescriptions

Approximately one in three residents in the Quad-County Regional has at least one chronic disease, with hypertension (high blood pressure) and obesity having the highest prevalence rates. The chronic disease prevalence rates for older adults are even higher (see exhibit 161). Many chronic diseases are treated with prescription medication. A 2019 KFF Health Tracking Poll<sup>11</sup> on prescription drugs revealed that about one in four adults say that it is “difficult” to afford their prescription medications and one in three adults reported not taking their medicines as prescribed in the past 12 months because of costs.

**Exhibit 19: Chronic Disease Prevalence**

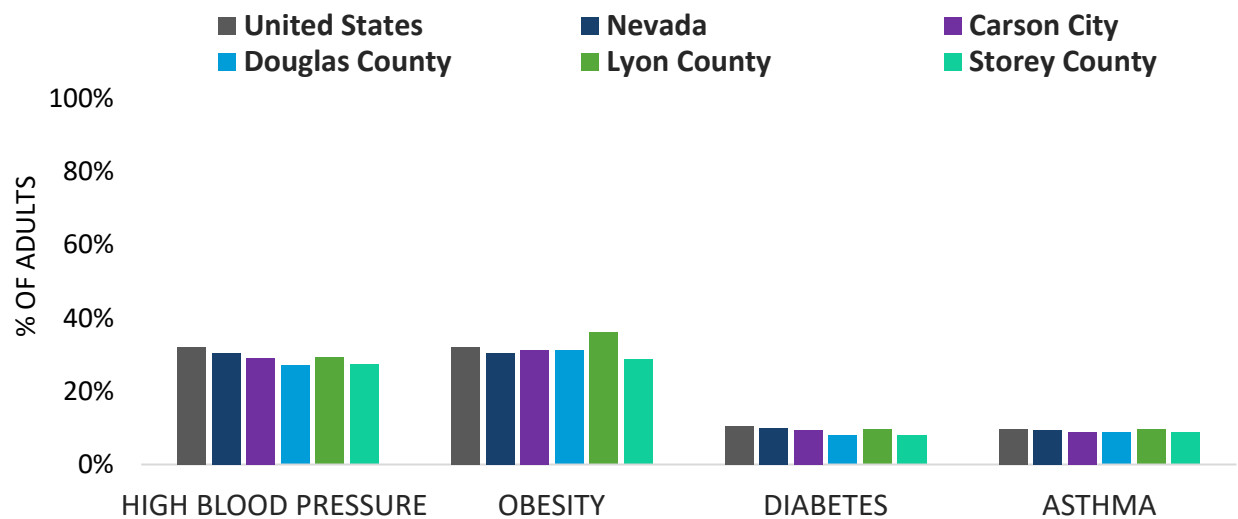

Source: National Center for Chronic Disease Prevention and Health Promotion, Division of Population Health. Behavioral Risk Factor Surveillance System, 2019

Access to affordable prescription drugs was ranked as the fifth highest need in the community survey overall and the top need for individuals younger than 35. Access to affordable prescription drugs was ranked third on the telephone survey. While affordability is one of the biggest challenges to prescription drugs, it is also the access to pharmacies in more rural

<sup>11</sup> KFF. KFF Health Tracking Poll – February 2019: Prescription Drugs. <https://www.kff.org/health-costs/poll-finding/kff-health-tracking-poll-february-2019-prescription-drugs/>



communities that can be a barrier, especially for individuals without reliable transportation. For example, a stakeholder in Storey County said, “There are no pharmacies here. We use Access to Healthcare (out of Reno), and they work with insurance. We have a post office, but you have to pick medication up, and for online meds, it has to be ordered online.”

### Access to Healthcare Services for Low-Income Individuals

The median annual household income varies across the counties in region from \$71,415 in Douglas County to \$58,305 in Carson City. While the percentage of households living below the federal poverty line (FPL) is less than the state and national population, approximately one in ten households live below 100% FPL in the Quad-County Region. Additionally, the percentage of uninsured individuals across the region varies by county from 10.1% in Carson City to 7.2% in Douglas County (see exhibit 133). It is estimated that approximately one in four adults with employer health plans are considered underinsured and likely struggle to pay for out-of-pocket healthcare costs.

**73.0%** of community survey respondents reported needing medical or medical healthcare in the past two years but chose **NOT** to get it.

In the community survey, approximately three in four survey respondents said that within the past two years there has been at least one occasion where they needed medical or mental healthcare, but chose not to get it. The most common reason was lack of money or ability to pay followed by long wait times to see providers. Additionally, the survey respondents ranked “affordable healthcare services for individuals and families with low income” as the eighth top community need.

## Access to Healthcare for Specific Populations



The Institute of Medicine defined access to healthcare as “the timely use of personal health services to achieve the best health outcomes<sup>12</sup>” in 1993. Healthy People 2020 further defined access to healthcare as four components: coverage, services, timeliness, and workforce<sup>13</sup>. Throughout the Quad-County Region, community residents have identified challenges to accessing healthcare services, especially in more rural communities. While access to primary care services was relatively good, stakeholders and focus group participants identified access to specialty care as more challenging. Additionally, cultural competency and transportation were also identified as top access to healthcare needs in the Quad-County Region.

### Access to Specialty Care

*“There is a lack of timely access to specialists. Where I am at, I try to get someone in with a neurologist and gastrologist; it takes two to three months, rheumatology is six months out.” – Stakeholder from Lyon County*

Higher chances of hospitalization and mortality are seen in residents who live in rural areas with limited access to specialist providers. Research has shown that patients who see a specialist in addition to their primary care provider are less likely to be hospitalized and die from a preventable disease.<sup>14</sup>

Timely access to see providers and a shortage of specialists is an identified need that came across during stakeholder interviews and focus groups. Some stakeholders identified the need for specific types of providers like pediatricians, endocrinologists, OBGYNs,

and other medical specialists. Many community residents need to travel to Carson City (from Douglas, Lyon, or Storey Counties) or Reno to access specialty care in a timely manner.

Additionally, the University of Nevada Reno School of Medicine’s Office of Statewide Initiatives’ Nevada Instant Atlas medical specialist counts indicate that there is a shortage of specialty care

<sup>12</sup> IOM. Access to Health in America. <https://www.ncbi.nlm.nih.gov/books/NBK235882/>

<sup>13</sup> HealthPeople.gov. Access to Health Services. <https://wayback.archive-it.org/5774/20220413202227/https://www.healthypeople.gov/2020/topics-objectives/topic/Access-to-Health-Services>

<sup>14</sup> Health Affairs. Lack of Access to Specialists Associated with Mortality and Preventable Hospitalizations of Rural Medicine Beneficiaries, 2019 <https://www.healthaffairs.org/doi/10.1377/hlthaff.2019.00838>

providers in the more rural counties, such as Lyon and Storey Counties. Carson City has a slightly higher rate of specialists than Nevada as a whole. (Note: see page 160 for data limitations regarding provider count).

**Exhibit 20: Medical Specialists**

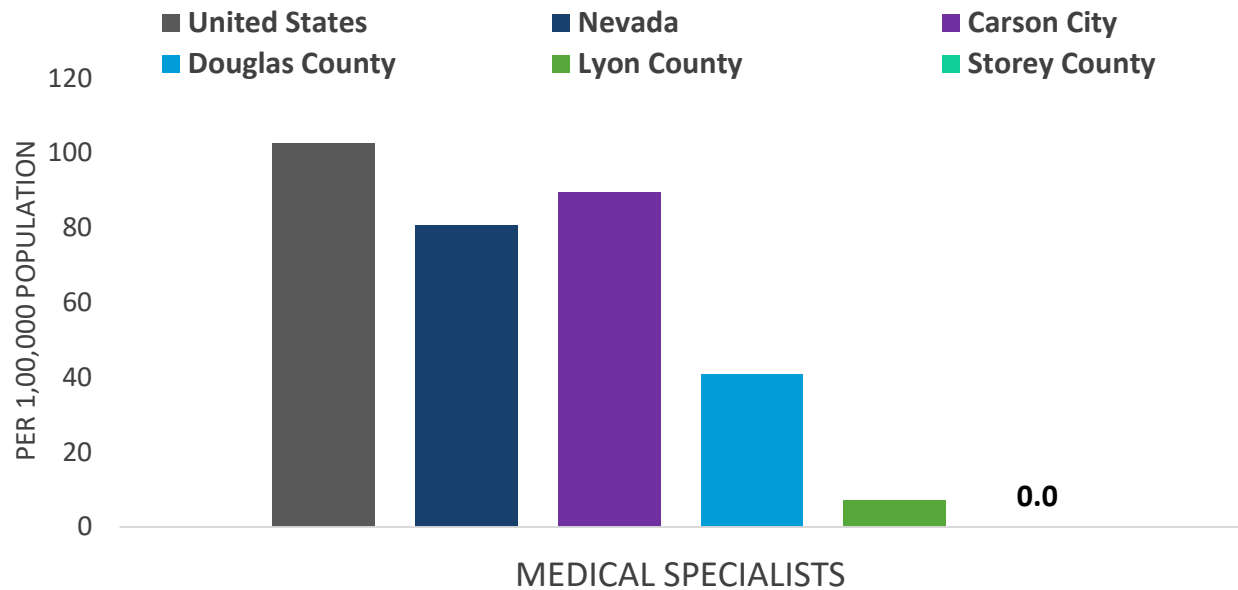

**Health System Competency & Access for Specific Populations**

In addition to a shortage of medical providers, provider competency, especially for the LGBTQ+ and Spanish-speaking population, was identified as a top community need that serves as a potential barrier for some subpopulations. The Hispanic or Latino population is the fastest growing population in the Quad-County Region (see exhibit 9). Approximately one in five individuals in Carson City speaks Spanish.

**Linguistic Isolation**

Language barriers can be a significant deterrent to accessing healthcare. People who do not speak English well are less likely to seek healthcare or receive health information. This can lead to delay of care and missed health screenings for chronic disease and cancers. Language isolation is also linked to poor mental health. Approximately 30.2% of the state’s population speaks a language other than English, and 15.0% of the CTH PSA.

*“Older Mexican Americans who live in low English-speaking neighborhoods are at greater risk for poor health and even early death.”*

*National Library of Medicine, 2021*

### Exhibit 21: Linguistic Isolation

	United States	Nevada	CTH PSA	Carson City	Douglas County	Lyon County	Storey County
English only	78.5%	69.8%	80.2%	77.6%	89.0%	86.5%	95.2%
Language other than English	21.5%	30.2%	15.0%	22.4%	11.0%	13.5%	4.8%
Spanish	13.2%	20.9%	11.7%	17.9%	8.1%	10.8%	0.3%
Other Indo-European languages	3.7%	2.4%	1.6%	2.2%	1.5%	1.4%	3.8%
Asian and Pacific Islander languages	3.5%	5.8%	1.2%	1.8%	1.0%	0.8%	0.3%
Other languages	1.1%	1.1%	0.5%	0.6%	0.4%	0.5%	0.4%

Source: U.S. Census Bureau, 2016-2020 American Community Survey Five-Year Estimates

- Over one-fifth of the population (22.4%) in Carson City speaks a language other than English, which is higher than the national percentage (21.5%).
- Over 11.0% of the CTH PSA population speaks Spanish. Approximately one-tenth of the populations in Douglas and Lyon Counties speak the language.

Several stakeholders, including several Equity Champions, identified the need for healthcare providers who understand the unique health needs of transgender people, especially youth, in the community. One stakeholder said “Providers are not trained, especially for transgender individuals. Youth are now coming out and transitioning at younger ages. We need doctors who are trained to work with young transgender individuals.” Another stakeholder shared, “There is a huge need for endocrinology for transgender care.”

### Transportation

Across the Quad-Counties, access to transportation is an area of concern voiced by community stakeholders. Community members mentioned challenges in accessing transportation to medical appointments and services around the community in particular.

Unreliability, timely access, and subpopulation criteria to public transportation were also themes heard in interviews.

Public transportation can impact a person’s health and influence health equity. Lack of transportation can cause an individual to miss their health appointments, or to delay scheduling, which can cause poorer health outcomes and added health

*“Transportation for elderly - sometimes they have to sit in the waiting room for hours waiting to be picked up and they get a timeframe such as a three-hour window, and they're just sitting in the waiting room for someone to get them.” – Stakeholder*

expenditures. Reliable transportation can improve stability in access to health, nutrition, employment opportunities, and social inclusion. Transportation ranked 26 on the community survey, however, it ranked higher in Storey (8) and Lyon (14) Counties compared to the other service areas.

## Mental and Emotional Health

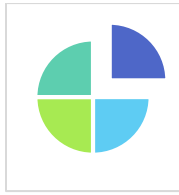

The 2022 State of Mental Health in America<sup>15</sup> reported that 19.86% of adults experienced a mental health illness in 2019. The report also found there is a growing percentage of youth in the country living with major depression, and suicidal ideation continues to increase among adults as well. The COVID-19 pandemic has had a huge impact on the mental health of both youth and adults across the country and the long-term impacts are yet to be fully discovered.

Access to mental health services is one of the most critical needs across the Quad-County Region as identified by the qualitative research and community and telephone surveys. Themes found across the counties included challenges in timely access, shortage of mental health providers, cost, and an increase demand of mental health services since the beginning of the pandemic.

### Providers for Youth and Adults

Mental health services specifically for youth and adults is an urgent and dire need in every community that participated in the qualitative research process. There are workforce shortages in mental health pediatric providers and mental health capacity within the schools, a shortage of education providers, and substance use concerns in the youth population.

In the community survey, counseling services for adults ranked number two below affordable housing followed by counseling services for youth at number three (see exhibit 54). When the community survey was further analyzed by age group, counseling services for youth was the top community need for survey respondents aged 55 and older

*“The available data for behavioral health providers in the region, while alarming in itself, does not speak to the severity of need for youth providers. Very few providers (if any, for parts of the region) specialize in youth or are able to support youth in any capacity.”*

— Leadership Group Member

<sup>15</sup> Mental Health America. The State of Mental Health in America. <https://mhanational.org/issues/state-mental-health-america>

(exhibit 221). Counseling services for youth ranked the second top community need in the telephone survey (exhibit 57).

Additionally, the University of Nevada Reno School of Medicine’s Office of Statewide Initiatives’ Nevada Instant Atlas indicate that there is a shortage of psychiatrists in the Quad-County Region. However, there are a greater number of psychologists available in the community, and also other providers of behavioral health care including Clinical Professional Counselors and Peer Support Specialists. See “Secondary Population Research: Behavioral Health” section of this report (pp. 206-207) for further detail.

**Exhibit 22: Psychiatrists & Psychologists**

	United States		Nevada		Carson City		Douglas County		Lyon County		Storey County	
	Rate	#	Rate	#	Rate	#	Rate	#	Rate	#	Rate	#
Psychiatrists <sup>16</sup>	15.6	ND	9.0	286	7.1	4	2.0	1	0.0	0	0.0	0
Psychologists	30.0	ND	14.5	459	44.3	25	12.0	6	3.5	2	0.0	0

Source: University of Nevada, Reno, School of Medicine. Office of Statewide Initiatives, Nevada Board of Psychological Examiners & Board of Osteopathic Medicine, 2020

**Capacity Across Acuity**

The mental health challenges range across the various levels of acuity from early screening and assessment, to outpatient services, to crisis and long-term care. The Quad-County Region does have some designated mental health beds, but access is limited due to barriers such as age of patient and insurance type. Finding beds for youth in crisis is especially difficult at times. With schools moving to remote models over the course of the pandemic, early intervention and prevention, especially among youth, was less robust and is now more important than ever.

*“On the pediatric side, we had kids in inpatient in the acute care hospital for months just waiting for a psych bed. It wasn't safe to send them home and there wasn't anywhere to send them locally. We had to send them all across the country just to find a psych bed.”*

*- Carson City Community Member*

**Social Connectivity**

A 2020 Health Affairs Health Policy Brief<sup>17</sup> reported that social isolation is a significant contributor to morbidity and early mortality. With COVID-19 restrictions, schools and offices

<sup>16</sup> MD & DO.

<sup>17</sup> Health Affairs. Social Isolation and Health. <https://www.healthaffairs.org/content/briefs/social-isolation-and-health>

going fully remote, many people across the country were isolated at home for long periods of time. Additionally, social isolation existed before the pandemic at alerting rates. A 2018 Cigna report<sup>18</sup> found that three in five (61%) of Americans reported feeling lonely.

The CHNA community survey asked a series of questions on social connectedness to begin to understand the extent of the challenges in the community, especially post-pandemic. Across geographies, no fewer than one in five respondents, and most commonly, at least one in three respondents, reported that the various types of support listed below were available to the “none” or “a little of the time.”

**Exhibit 23: How often is each of the following kinds of support available to you if you need it? Measure reported is percentage of patients answering “none” or “a little of the time”**

PERCENT SAYING, "NONE" OR "A LITTLE OF THE TIME"	Carson City	Douglas County	Lyon County	Storey County	CTH PSA	Total
Someone you can count on to listen to you when you need to talk	35.1%	28.0%	34.6%	38.6%	21.6%	<b>33.4%</b>
Someone to give you information to help you understand a situation	34.5%	31.3%	38.3%	44.6%	26.3%	<b>35.1%</b>
Someone to confide in or talk to about yourself or your problems	34.0%	30.3%	34.7%	38.6%	26.7%	<b>33.5%</b>
Someone to turn to for suggestions about how to deal with a personal problem	35.3%	30.2%	39.0%	43.6%	25.8%	<b>35.3%</b>
Someone to help you if you were confined to bed	36.8%	34.2%	41.7%	39.6%	30.7%	<b>37.2%</b>
Someone to take you to the doctor if you needed it	34.3%	32.1%	36.6%	36.6%	25.9%	<b>34.3%</b>
Someone to help with daily chores if you were sick	36.3%	34.6%	34.0%	38.6%	30.1%	<b>35.6%</b>
Someone who hugs you	39.5%	29.1%	35.0%	48.5%	23.9%	<b>36.7%</b>
Someone to love and make you feel wanted	35.9%	31.5%	36.3%	38.6%	26.0%	<b>35.0%</b>

<sup>18</sup> Cigna. Loneliness and the Workplace. <https://www.cigna.com/static/www-cigna-com/docs/about-us/newsroom/studies-and-reports/combatting-loneliness/cigna-2020-loneliness-factsheet.pdf>



QUAD-COUNTY REGIONAL COMMUNITY HEALTH NEEDS ASSESSMENT

PERCENT SAYING, "NONE" OR "A LITTLE OF THE TIME"	Carson City	Douglas County	Lyon County	Storey County	CTH PSA	Total
Someone to get together with for relaxation	35.9%	28.7%	30.4%	44.6%	25.6%	<b>33.7%</b>
Someone to do something enjoyable with	33.5%	30.9%	30.4%	38.0%	26.0%	<b>32.6%</b>

## Substance Use Prevention, Treatment, and Recovery



A recent KFF report, [Recent Trends in Mental Health and Substance Use Concerns Among Adolescents](https://www.kff.org/coronavirus-covid-19/issue-brief/recent-trends-in-mental-health-and-substance-use-concerns-among-adolescents/#:~:text=Some%20research%20has%20shown%20that,in%20substance%20use%20in%202021.), reported that deaths due to drug overdose in adolescents nearly doubled nationally in the first year of the pandemic<sup>19</sup>. Additionally, a third of high school students reported using substance such as alcohol, tobacco, marijuana, and misuse of prescription opioids in 2021. As of April 2022, over 100,000 people have died of drug overdose largely due to fentanyl<sup>20</sup>.

*“There are a lot of opioids, meth, and Fentanyl. It just seems like everywhere I turn someone is getting poisoned to death.”* Stakeholder from Douglas County

While much of the data for substance use during COVID-19 has yet to be analyzed and released to the public, through conversations with stakeholders and focus group participants in the Quad-County Region, the need for substance use prevention, treatment, and recovery programs is vital to the overall health of the community.

Survey respondents ranked “programs to help drug and other substance use disorder patients in recovery stay healthy” as the ninth top community need followed by substance use treatment services at 13 and drug and other substance abuse early intervention services as 15.

Data from the State of Nevada Department of Health & Human Services Office of Analytics reported that between 2017 and 2019, Lyon County experienced the highest rate of substance use-related deaths per 100,000 population, over twice as high compared to Douglas County (see table below). Several stakeholders indicated that there are very little prevention programs, especially for youth, available in the community due, in part, to lack of funding as well as grant criteria and restrictions on available funding.

<sup>19</sup> KFF. Recent Trends in Mental Health and Substance Use Concerns Among Adolescents. <https://www.kff.org/coronavirus-covid-19/issue-brief/recent-trends-in-mental-health-and-substance-use-concerns-among-adolescents/#:~:text=Some%20research%20has%20shown%20that,in%20substance%20use%20in%202021.>

<sup>20</sup> CDC. Provisional Drug Overdose Death Counts. <https://www.cdc.gov/nchs/nvss/vsrr/drug-overdose-data.htm>

**Exhibit 24: Substance Use-related Mortality Rate**

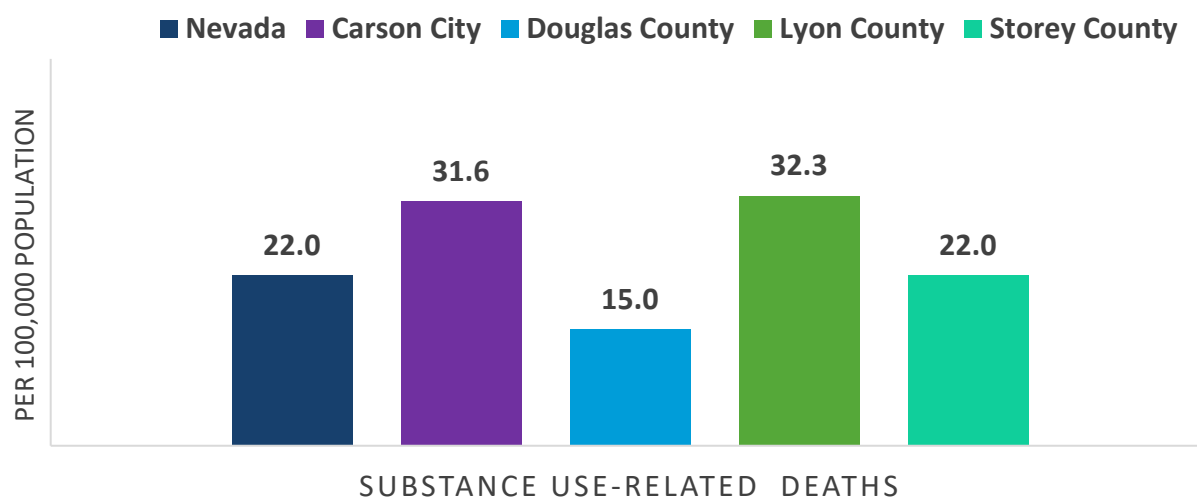

PER 100,000 POPULATION	Nevada	Carson City	Douglas County	Lyon County	Storey County
2017-2019	22.0	31.6	15.0	32.3	22.0

Source: State of Nevada Department of Health & Human Services Office of Analytics. 2021 Nevada Health Profiles

Youth substance use continues to be a problem across the Quad-County region, with especially high rates of electronic vapor products and alcohol.

**Exhibit 25: High School Student Self-Reported Lifetime Substance Use<sup>21</sup>**

GRADES 9 TO 12	Nevada	Carson City	Douglas County	Lyon & Storey County
Alcohol	56.9%	63.1%	69.3%	63.1%
Cigarettes	18.0%	24.7%	21.4%	28.7%
Cocaine	5.2%	10.6%	8.9%	6.2%
Ecstasy	4.8%	6.5%	8.7%	6.3%
Electronic vapor products <sup>22</sup>	43.5%	61.4%	58.0%	57.7%
Heroin	2.5%	2.8%	1.9%	2.5%
Injectable Substances	2.2%	2.2%	1.2%	2.9%
Marijuana	35.4%	48.0%	40.5%	39.2%
Methamphetamines <sup>23</sup>	2.9%	5.5%	1.8%	3.8%
Prescription Pain Medicine <sup>24</sup>	18.8%	21.7%	18.2%	17.1%

Source: State of Nevada, Division of Public and Behavioral Health and the University of Nevada, Reno. 2019 Nevada High School Youth Risk Behavior Survey Report

<sup>21</sup> Percentage of students who answered, 'yes'.

<sup>22</sup> Including e-cigarettes, vapes, vape pens, e-cigars, e-hookahs, hookah pens, and mods such as JUUL, Vuse, MarkTen, and blu

<sup>23</sup> Used methamphetamines (also called "speed", "crystal meth", "crank", "ice", or "meth").

<sup>24</sup> Percentage of high school students who ever took prescription pain medicine without a doctor's prescription or differently than prescribed (codeine, Vicodin, OxyContin, Hydrocodone, and Percocet).

## Qualitative Research Approach

The qualitative primary research methodology consisted of stakeholder interviews and focus group discussions with key community organization leaders and service providers, healthcare providers, policymakers, and community residents. An interview guide and focus group moderator’s guide were implemented to help guide conversations, found in Appendix D and E.

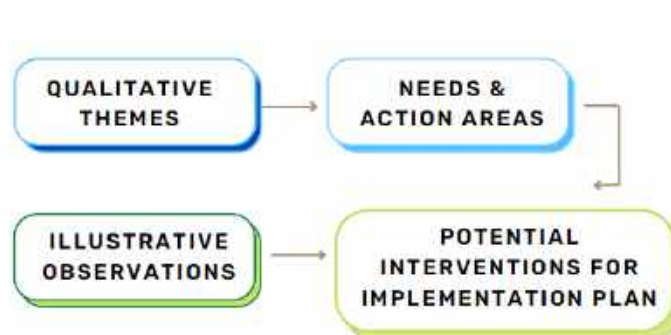

Qualitative data collection resulted in a consensus of several top areas of need that can be described as qualitative themes. Each of these qualitative themes impact the subsequent high-level action areas. The action areas include an overview of the subject and utilize de-identified illustrative observations in italics which are representative of respondents’ consensus perspectives.

### One-on-One Interviews

In total, **46** one-on-one virtual phone interviews were conducted, lasting approximately 20 to 30 minutes, although some community members chose to share a great deal of information and exceeded 30 minutes. These conversations provided the opportunity for:

- In-depth conversations about the strengths and challenges to receiving healthcare, services, impacts of the COVID-19 pandemic, and ideas for solutions to improve their communities.
- In-depth discussions about healthcare, social service, mental health, and other service issues with leaders, community partners, and individuals from the community.

### Focus Group Discussions

**Fifteen** community-wide focus groups with over 125 community participants in total were conducted. Due to a number of focus groups taking place as an open forum at established community meetings, as well as some offered as hybrid in-person and Zoom meetings, an exact headcount of total focus group participants is not available. Each focus group started with brief introductions, followed by hearing participants’ broad thoughts about topic areas. Discussions were narrowed down to focus on topics participants observed as the greatest concerns facing their community and what possible solutions they envisioned. Participants were encouraged to

speaking about their particular areas of concern, interest, or experience as many opinions and observations were grounded in both personal and professional experiences.

## Qualitative Data Collection Participants

Through the stakeholder interviews and focus groups, a diverse group of community organizations provided valuable insight into the challenges and barriers community residents may experience in the Quad-County Region.

**Exhibit 26: Qualitative Research Participants**

Qualitative Research Participants	
Boys & Girls Clubs Of Western Nevada	Nevada Urban Indians
Carson City Behavioral Health Task Force	PFLAG Carson City
Carson City Fire Department	Nevada Division of Healthcare Financing and Policy
Carson City Health And Human Services	Carson Medical Group
Carson City Sheriff's Office	Douglas County East Fork Fire Protection
Carson Tahoe Behavioral Health Assertive Community Treatment	Storey Senior Citizens Center
Carson Valley Community Food Closet	Turning Points Inc.
Carson Valley Medical Center	Storey County Emergency Department
Carson Valley Veteran's Affairs Clinic	Storey County Community Relations
Community Chest, Inc.	Nevada Department of Health and Human Services Division of Welfare and Supportive Services
Douglas County Behavioral Health Task Force	Nevada Business Group on Health
Douglas County School District	JOIN Inc.
Friends In Service Helping (Fish)	Partnership Douglas County
Healthy Communities Coalition of Lyon And Storey Counties	Ron Wood Family Resource Center
Lyon County Human Services	Storey County Community Library
Lyon County Juvenile Probation	Tahoe Youth & Family Services
Lyon County Public And Behavioral Health Task Force	Tahoe Youth & Family Services
Lyon County School District	Washoe Tribe Health Center
Nami Western Nevada	Western Nevada College
Nevada Association Of Counties	Northern Regional Behavioral Health Policy Board

## Insights into the Quad-County Region

Community stakeholders were asked to share positive traits about their community. Quad-County residents expressed a sense of support and collaboration throughout their communities. Residents also appreciate the natural beauty and weather that the Quad-County region has to offer.

### Sample voices from the Community

- *“The community spirit is amazing. It is a community that cares about each other and looks for ways to live in harmony.” -Carson City*
- *“We are a supportive community and a community that wants involvement from hospitals, city government, and agencies.” -Carson City*
- *“We have a very loyal and close-knit patient base and I think overall the compliance and care recommendations are good. I think the area kind of attracts persons who enjoy the semi-rural aspect of Carson City.” -Carson City*
- *“How caring people are and willing to wrap around and help when there is a tragedy or need. People donate, volunteer, and work with organizations and they want to interact with people.” -Douglas County*
- *“We have the best weather. We have lots of community activities. We have every outdoor activity that you can think of available year-round.” -Douglas County*
- *“It is a pretty close-knit community. We are a small town, and the town pulls together when there are issues or something goes on.” -Lyon County*
- *“I think in the end we have each other’s backs. People step up and help one another. It is a town that has a lot of diversity not ethnically or racially but in economics and gender identification. It is a place that has real commitment to create events so people can be involved.” -Storey County*

## County-Level Action Areas

The following section highlights county-level needs identified through the qualitative research.

**Exhibit 27: Unique Qualitative Themes by County**

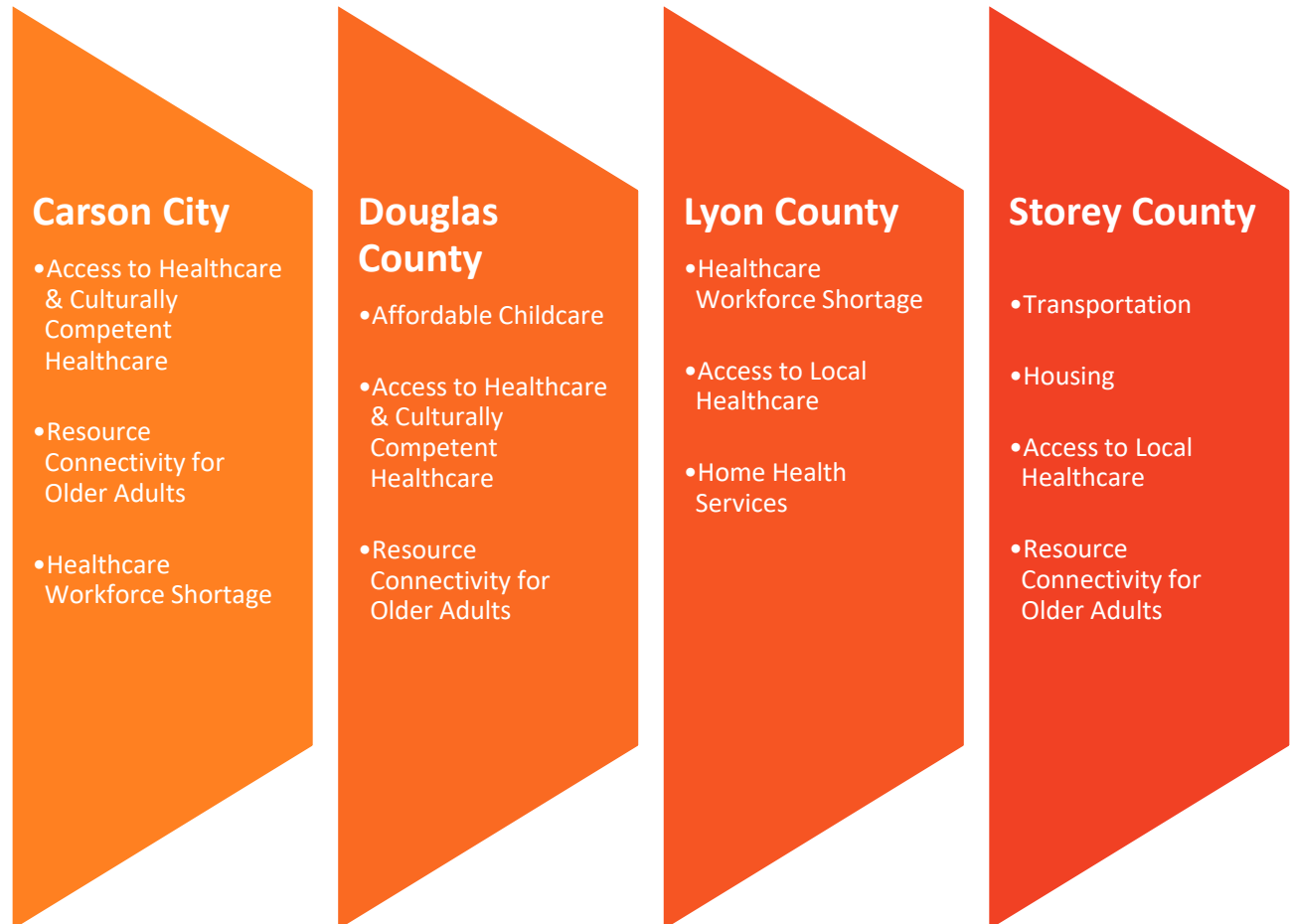

## Voices of Carson City

Access to healthcare for the Spanish-speaking, New American, and older adult community were highlighted in one-on-one and group conversations. These challenges are exacerbated by workforce shortages in the healthcare sector and financial barriers to services. Carson City is largely viewed as the healthcare and services hub of the Quad-County Region and many people drive long distances from the more rural counties to seek care and services in Carson City.

### Sample voices from the community

- **The Spanish-speaking New Americans are facing financial barriers to accessing healthcare, as well as feeling fearful when trying to access healthcare.**

*“Financially, the immigrant population is not able to pay rent and when they come to the hospital, they can't afford hospital bills.”*

*“A lot of people have fear around going to the doctor and if they are here illegally, then doctors won't want to give them treatment.”*

- **Older adults are a vulnerable population that faces many challenges in accessing resources, including healthcare, in Carson City. Community members voiced that many older adults are unaware of what services they are eligible to receive.**

*“We have a large senior population and often they don't know how to access resources or don't qualify for resources. From the EMS side, our biggest struggle is to and from appointments for people with disabilities and wheelchairs who can't walk more than 10 feet in their walker.”*

*“There are very limited transportation services for them. We have public transportation, but people have to get all the way to the curb out by the bus by themselves.”*

*“We have a lot of seniors, and a lot of people won't take new Medicare patients. A lot of seniors have no access to primary care and when they do, they are struggling because they have no family support here.”*

*“There is a struggle that a lot of the doctors are refusing to take senior care patients for those on Medicare or Medicaid.”*

- **The healthcare system in Carson City is facing healthcare workforce shortages causing patients to have longer wait times to see their primary care provider, specialists, and behavioral health providers. Healthcare providers also mentioned that workforce recruitment of more providers in Carson City is a challenge. Additionally, throughout the COVID-19 pandemic, healthcare providers have left the sector.**

*“For certain specialists, we struggle to get patients in. For example, it is six to nine months for rheumatology.”*



*“The pandemic drove a lot of technical people out of here, especially nurses and doctors, a lot of retirements.”*

*“For a cardiologist, a patient is waiting until December because he can’t get to Reno – except if they want to go at 6:00 in the morning and get home at 6:00 at night, but for seniors that is not appropriate.”*

## Voices of Douglas County

Douglas County residents cited a noticeable disconnect between community-based resources and services and older adults, predominantly caused by technology and transportation-related challenges. There is a lack of culturally competent community-based resources and services for the growing Spanish-speaking community, including behavioral health and healthcare. Many stakeholders discussed frustration at the lack of quality translation services, especially for the Spanish-speaking older adult community. Additionally, there is a general lack of affordable, safe childcare.

### Sample voices from the community,

- **For older adults in Douglas County, there are challenges to enrolling in general community-based services, exacerbated by most information being online and often inaccessible.**

*“I think a lot of the elderly population is not sure where to go to get a lot of information. Many don’t understand how to access services online nor have the desire to learn how to access things online.”*

*“During COVID, seniors struggled with using online services because they have very spotty internet connection. We have a mobile crisis team, Mobile Outreach Safety Team (MOST) that goes out two days a week. Older adults will call just to get someone to take out their trash. The calls are getting more aggressive when we tell them we can’t help them, and it’s hard to tell if it’s Alzheimer’s or Dementia or other mental health issues.”*

*“The aging population is the biggest health concern. Our average age has risen from 43 to 50 years in the last two years. More older people are coming here and moving away from their family and living on their own. Their spouse may or may not be around. It is hard for single older people to find social activities.”*

- **Stakeholders who identify and/or work in the Spanish-speaking community highlighted the need for more Spanish-speaking providers and sufficient translation services. Children often have to translate for parents and family members at healthcare appointments.**

*“Providers don’t seem to understand the burden on the children who translate to their parents. The information may not be translated correctly. It could lead to a dangerous situation, diabetes, heart disease, etc.”*

*“Many providers won’t use a translator unless they are certified. Some providers use the call-in translator but it’s terrible.”*

*“For Spanish-speaking elderly, our community health workers will be on the phone for hours. We have a lack of services for them.”*

- **There are a limited number of mental health providers that speak Spanish, and some community members feel uncomfortable speaking Spanish because providers have not been welcoming towards their language and cultural needs.**

*“Access to mental healthcare is challenging for Spanish-speaking communities. For the kids, they speak English so it is not a problem to have a therapist that only speaks English, but for the parents it’s hard part because they don’t speak English and there are not many Spanish-speaking therapists and mental health providers. For adults that don’t speak English, they can use an interpreter, but a lot is lost in translation.”*

*“Too many providers say that if you live in this country that you need to speak English. It’s demeaning and it turns that Hispanic person off from seeking medical care.”*

*“We have no mental health providers that speak Spanish in Douglas. Trying to get services is nearly impossible and families are desperate for mental health and medical providers”*

- **A number of community members are concerned with the affordability of local childcare. There are very limited childcare facilities, no infant childcare, and long wait lists. A lot of parents are working to pay for childcare because childcare is so expensive.**

*“There’s one good facility and you need to get on the waiting list before you’re even pregnant.”*

*“We had someone here that has four kids, and it’s like she is working to pay for the summer care.”*

*“In general, we need more childcare facilities, there are only five places. They don’t take many kids and it’s very expensive. Many parents don’t work because it only covers gas and childcare. When COVID hit, I had three kids in day care and I paid \$1,700 every paycheck and I have a 50% discount due to my family owning the facility.”*

*“There has been increased truancy due to older children watching a younger child. They might miss a couple of days of school a week. Especially with a language barrier.”*

## Voices of Lyon County

Discussions with Lyon County residents reveal that there is a lack of home health services for older adults and populations living with disability and other mobility challenges, caused by workforce shortages and the unwillingness or inability of agencies to send staff to rural areas. The distance to basic community-based services in the county creates barriers. According to residents, there is limited access to healthcare services, emergency medical services (EMS), and limited hospital resources in the county.

### Sample voices from the community,

- **Home health is an area that has been hit hard during the COVID-19 pandemic and has caused services to be spread thin across the county.**

*“Home health agencies don't reimburse staff for gas or mileage. We are so geographically far apart that it's not feasible for them to make minimum wage and spend half of it on gas.”*

*“During COVID, we lost a lot of in-home care providers, and they never came back. They lost their jobs due to restrictions and then they became part of the great resignation.”*

- **Many community stakeholders cited that the rural communities in the county, such as Silver Springs, are isolated and have limited access to resources.**

*“Silver Springs is an isolated community with limited access to transportation. The fire department becomes their front-line providers. We have a lot of isolated people in Silver Springs with poor health. It is a medical desert.”*

*“Silver Springs has no transportation, so it adds to the disparity. In Dayton, we're really seeing food insecurity hit home to a lot of folks that were normally not food insecure, so we are really grateful that we have food pantries.”*

- **Stakeholders shared that there is only one hospital in Lyon County. Specialty care access is lacking, and for the majority of services, patients have to travel outside of the county. EMS is an area that is facing challenges due to shortages in volunteers. This shortage is causing more patients to be transferred to other facilities by Care Flight. Community members stated that there is also a sense of high provider turnover.**

*“We do not have any OBGYN services, so if you are pregnant, you have to travel out of town for arrangements. We don't have a surgery center, so if you have a broken arm you have to drive outside of the county.”*

*“EMS is volunteer-based, and we have to transport out of that hospital and out of the emergency room. EMS transport and volunteer resources are challenging to come by*

*because they have to cover the entire local area. They have a limited crew. Approximately 70% to 80% of patients who get transferred are done via Care Flight but only 10% to 15% require that.”*

*“We have so many of our folks out here, both young and old, and I’m not an expert, but the fact that these folks have to travel two to three times a week for their dialysis, it’s upsetting.”*

*“We go through a physician’s group that contracts traveling doctors for short stents. They don’t know our problems and they don’t know the community. By the time they get to understand and get a sense of the community, they go somewhere else.”*

## Voices of Storey County

The geographically fractured nature of Storey County’s communities and the distance to services creates challenges in accessing healthcare and health-related services for the residents in Storey County. Common themes included a lack of access to affordable housing, a lack of healthcare programs accessible to all community members, challenges with transportation from Virginia City to neighboring cities, and little to no access to pharmacy facilities. The older adult population suffers from isolation in Storey County as well. Stakeholders shared that older adults in the community experience longer periods of isolation than in other communities.

### Sample voices from the community:

- **An absence of local medical and pharmacy care has created many barriers to access for residents of Storey County.**

*“We have no doctors, hospitals, or pharmacies in Storey County. Telehealth has been helpful, but it is limited and there are challenges with the senior population. Seniors don’t have internet, don’t understand technology. We do have a health clinic here one day a week, but it’s often limited. We do have access to telehealth, but again can be limited.”*

*“Virginia City is geographically distant from major services. People have to drive to Carson City or Reno. It is a very windy road to go down to get services. I think part of the problem is it’s difficult for those outside of our county to understand the dynamics of it. We are one geography split up into four sections, so it is very geographically cut off.”*

*“There are no pharmacies here. We use Access to Healthcare (out of Reno), and they work with insurance. We have a post office, but you have to pick medication up, and for online meds, it has to be ordered online”*

- **To access an array of healthcare and community-based services, Storey County residents must drive or find transportation outside of the county. Resources are often scattered throughout communities, creating further difficulties.**

*“It is a 20-minute drive, and it is not about the length of drive it is the elevation change, especially in winter when we could have two more feet of snow up here than they do down there.”*

*“There’s a new online system but it’s not always effective. It makes it very hard for people without reliable transportation. People can’t just go somewhere at a drop of a hat. This has been happening a lot with chemo appointments. Carson doesn’t seem to understand the rural community and distance, travel, and weather. We’re not just down the road from them. Carson needs a way to flag the people that we know that have*

*transportation or out-of-town challenges, and that they are the ones that aren't getting canceled."*

- **Older adults have even less access to resources, decreasing the overall quality of life for a critical part of the Storey County community.**

*"Seniors can't get out and go to places easily. Seniors just sit in their homes. They don't get out. There is a community effort to help one another, but many seniors are virtually shut-ins. It significantly affected their mental health. They fear going outside for their health. They lost the socialization from the senior center."*





*"Seniors call the senior center or friends to help them get along. Kids don't care about their parents 90% of the time. The senior center is the emergency contact for many of our seniors as they don't have family."*

## Quad-County Region High-Level Action Areas from Qualitative Data Collection

Each of the themes noted in the bullets below are evident in the subsequent observations on each action area. Each of the key Action Areas and de-identified illustrative quotes are representative of respondents’ consensus perspectives.

**Action Areas are in alphabetical, not prioritized, order.**

**Exhibit 28: Overarching High-Level Action Areas in the Quad-County Region**

 <p>Housing</p>	<ul style="list-style-type: none"> <li>• Affordable housing</li> <li>• Housing stock</li> <li>• Population experiencing homelessness</li> </ul>
 <p>Mental Health</p>	<ul style="list-style-type: none"> <li>• Shortage of providers for youth and adults</li> <li>• Lack of crisis services</li> <li>• Lack of social connectivity</li> <li>• COVID-19 impacts</li> </ul>
 <p>Speciality Healthcare</p>	<ul style="list-style-type: none"> <li>• Long wait times</li> <li>• Shortage of providers</li> </ul>
 <p>Substance Use</p>	<ul style="list-style-type: none"> <li>• Increased usage of substances</li> <li>• Lack of treatment facilities and beds</li> <li>• Lack of prevention and recovery services</li> </ul>
 <p>Transportation</p>	<ul style="list-style-type: none"> <li>• Unreliability and timely access</li> <li>• Exclusive criteria</li> </ul>



## Housing

Across the Quad-County Region, residents face a variety of housing challenges. Many stakeholders voiced challenges surrounding themes of affordable housing, housing stock, and a lack of resources for those experiencing housing insecurities. The lack of affordable housing is affecting residents of all income levels for both home buying and rentals. Low-income housing is limited across the Carson Tahoe Health PSA and the Quad-County Region.

*“Rents are in the \$2,000 range and most of our clients live on less than \$900 a month. We’ve got motels that have transitioned to a monthly rate and people are paying \$900 a month to live in a facility with no kitchen or other amenities”.* - Focus Group Participant

### The community voiced their concern and frustration about the lack of affordable housing for middle-income and low-income people and families within the Quad-County Region.

- *“Low-income housing is very limited. It is not very affordable even with two people working full-time jobs.”* - Carson City
- *“Rentals in Virginia City are unaffordable. The average is \$2,400 a month for tiny little apartments above shops.”* - Storey County
- *“[Apartment complex] went up too high, and rents are in the \$2,000 range, and most of our clients live on less than \$900 a month. We’ve got motels that have transitioned to a monthly rate and people are paying \$900 a month to live in a facility with no kitchen or other amenities.”* - Carson City
- *“A lot of landlords are not willing to work with voucher-type programs. People wait to get Section 8 housing and then they end up living in their cars or doubling up or becoming homeless.”* - Carson City
- *“It’s way too expensive. There are fewer mobile home parks than there used to be and that used to be the affordable housing for most people. We are seeing people get more and more housing vouchers, but no landlords will take them.”* - Douglas County
- *“Safe housing that is affordable is a different story. There are very few median-income houses that are on the market, and they are priced at \$550,000. Prices have gone really crazy.”* - Douglas County
- *“In Mark Twain, Lockwood, and Highlands, there are individual homes; Highlands is more wealthy housing. Lockwood’s are smaller homes for those with lower incomes. In Virginia City, there are a lot of*

*buildings that are from the 1800s and are privately owned homes.” - Storey County*

**Community members cited a severe lack of housing stock, exacerbated by large corporations moving into the area, which are causing an unexpected influx of residents from outside of Nevada who are able to afford the majority of rental properties.**

- *“There is nothing for first-time homebuyers. You have to put in about 40 offers. The inventory is low.” – Carson City*
- *“I have lost employees because they couldn’t find rentals.”- Douglas County*
- *“Douglas County is one of the most expensive places to live. A one-bedroom studio is \$1,800.” – Douglas County*
- *“There are not a lot of multi-family housing available and recently we have seen big growth.” – Douglas County*
- *“We have several apartment complexes. The other issue is we have a start-up copper mine; it has taken a lot of rentals and made them unavailable because people are coming from out of town to get jobs.” - Lyon County*
- *“The housing stock is old and it's unsafe for many seniors. A lot of the staircases are very narrow. Many people live in travel trailers.” - Storey County*

**Many stakeholders across the service area discussed how the support and availability of housing is impacting the housing insecure and people experiencing homelessness.**

- *“There’s a lot of homeless families and they won’t go into the shelters because they will split the families up.” - Carson City*
- *“Connecting folks that need them with services that are available that are homeless, and stressed families don't know about the resources available.” - Carson City*
- *“Veterans are getting kicked out and priced out. Veterans are ending up homeless and there is no homeless shelter.” - Douglas County*
- *“The Dayton area does have a small homeless population. There is the bridge in Dayton, and you’ll find 30 to 50 homeless people camped out in there.” - Lyon County*

- *“Homelessness and people of low socioeconomic status – we really need to start addressing housing.*

*People are living out of their cars or are doubling up. We have no shelter.” - Storey County*

## Mental Health

Access to mental health services is one of the most critical needs across the Quad-County Region. The majority of stakeholders in both one-on-one interviews and focus groups are concerned with mental health access. Themes found across the counties included challenges in timely access, shortage of mental health providers, cost, and an increase demand of mental health services since the beginning of the pandemic. Mental health services specifically for youth and seniors is an urgent and dire need in almost every community that participated in the qualitative data collection process. There are workforce shortages in mental health pediatric providers and mental health capacity within the schools, a shortage of education providers, and substance use concerns in the youth population.

*“On the pediatric side, we had kids in inpatient in the acute care hospital for months just waiting for a psych bed. It wasn't safe to send them home and there wasn't anywhere to send them locally. We had to send them all across the country just to find a psych bed.”*

*- Carson City Community Member*

### Community members explained the several challenges to accessing mental healthcare services:

- *“For mental health, we don’t have enough options for people to access care on the outpatient side especially. Inpatient, you can get a bed within reason but when they need outpatient, the rehab options we have is one facility that is very good and is able to accommodate in-patient rehab centers.” - Carson City*
- *“We lack services for the youth. There is no funding or infrastructure for mental health. We don’t have anything lower than an inpatient facility or the hospital. There is nothing in between.” - Carson City*
- *“Depression and anxiety have skyrocketed. It's mainly what a lot of are people struggling with and it's worse than prior.” - Douglas County*
- *“There are a lack of mental health resources and the resources available are stretched thin. Nonprofits are trying to fill the void but there is a lack of resources for children. Some hospitals don’t have youth mental health screenings.” - Douglas County*
- *“Seniors have a pretty high mental health burden. In June we had six completed senior suicides.” - Douglas County*
- *“We have some counselors at the Community Chest. If it's something more severe, then you need to go out of the community. We do have a*

*local and state crisis line. It's being transferred to 988, but that has*

*some issues. Many people will call 911.” - Storey County*

**Since the COVID-19 pandemic, stakeholders stated that there has been an increase of mental health needs throughout the service area counties.**

- *“We get a significant amount of medical calls that are really suicidal or mental health related issues. We're getting more suicidal ideations. Community Chest counseling services increased 50% over the course of the pandemic.” - Storey County*
- *“Behavioral health is becoming a bigger problem for youth due to the pandemic.” - Storey County*
- *“We have seen an increase of mental health issues since COVID in our youth and senior population. We have had seven juveniles in the emergency room for suicide ideation and we only have a total of seven beds in the hospital. There is nowhere to take them.” - Douglas County*

**The community cited a critical shortage of mental health providers who have availability and accept specific health insurance plans:**

- *“Our biggest challenge is mental health. We don't have many outpatient psychiatrists, only one total, but they are not taking new patients. When we try to refer, there are no psychologists or therapists that are taking new patients. As primary care providers, we do a lot more therapy work and psychiatry medicine than what we are supposed to do.” - Carson City*
- *“Schools try to help mental health, but the staff is limited. In the elementary school, there is one counselor for five schools.” - Carson City*
- *“My middle school-aged son is very anxious, but there is no school identifying the need. It took about four to five months to get into seeing a provider.” - Carson City*
- *“It is a mental health desert here. We have a few counselors, and a couple of psychologists, but no psychiatrists. You have to go to Carson City to get mental healthcare. There are options for online appointments. The counselors here are full.” - Douglas County*
- *“There are no psychiatrists; we have to refer to Reno or use telehealth.” - Douglas County*
- *“Our local providers are tapped. Our behavioral task force does have a lot of behavioral health providers and most of them have a week to three-week waitlist. South Lyon medical center has a little better access to*

*mental health. Silver Springs doesn't really have anything." - Lyon County*

- *"Many providers have a four to six-month waiting list, which doesn't help with medication access and management." - Douglas County*
- *"It was a four-month waiting list to get a kid on a mental health treatment list." - Lyon County*
- *"There are a lot of mental health providers that are booked four to five months out. I don't want to wait so long." - Carson City*
- *"There are people who don't have insurance, and a lot of facilities cost a lot out of pocket." - Carson City*
- *"There are not enough of community-based services and Medicaid dollars for mental health services, and it needs to be increased. The state only funds six residents for psychiatrists." - Carson City*
- *"Not a lot of providers take insurance due to the hoops to jump through or the low reimbursement rate. They might have 15-20 Medicaid providers in Douglas. They can't pay cash rate and afford copays." - Douglas County*

## Specialty Healthcare

Higher chances of hospitalization and mortality are seen in residents who live in rural areas with limited access to specialist providers. Research has shown that patients who see a specialist in addition to their primary care provider are less likely to be hospitalized and die from a preventable disease.<sup>25</sup>

Timely access to see providers and a shortage of specialists is an identified need that came across during stakeholder interviews and focus groups. Competent healthcare for the LGBTQIA+ community was also highlighted as a gap in services.

*“In all four counties, it’s a crisis. We don’t have the workforce. We are trying to build up Community Health Workers. One of the issues from my perspective is Medicare – the split between rural and urban is deplorable.*

*In rural areas, we can’t access senior healthcare and we are bound to go to the city. We don’t have the same options with insurance.”*

*- Storey County Community Member*

### The community identified several barriers to accessing equitable, quality, and local healthcare services in a timely manner:

- *“There are long wait times to see primary care and some of the specialty appointments.” - Carson City*
- *“If you are in a wheelchair, you need to navigate how to get to these facilities by yourself. There is no help.” - Carson City*
- *“For pediatric appointments, they fill up quickly and there is always a wait.” - Douglas County*
- *“There are really long wait times to get into a general practitioner.” - Lyon County*
- *“There is a lack of timely access to specialists. Where I am at, I try to get someone in with a neurologist and gastrologist; it takes two to three months, rheumatology is six months out.” - Lyon County*

### Shortages of specialty healthcare providers is a frequent challenge most stakeholders mentioned:

- *“We need more OBGYNs and more providers in general. We have another OBGYN starting next year, but that’s not going to be enough. Our physicians are trying to fit many patients in a day and there are only*

<sup>25</sup> Health Affairs. Lack of Access to Specialists Associated with Mortality and Preventable Hospitalizations of Rural Medicine Beneficiaries, 2019 <https://www.healthaffairs.org/doi/10.1377/hlthaff.2019.00838>

*so many hours in a day.” - Carson City*

- *“The struggles are referrals to specialists. We have four neurologists, and for a while we had none. Now we only have one rheumatologist and to see that doctor, it is over a year out. We only have two endocrinologists.” - Carson City*
- *“Providers are not trained, especially for transgender individuals. Youth are now coming out and transitioning at younger ages. We need doctors who are trained to work with young transgender individuals.” . Carson City*
- *“Access used to be okay; about five years ago I would say it was fair, but*

*it has taken a downturn in the last couple of years. Lots of providers have retired or left the practice, left the county for greener pastures. Patients are finding it difficult to find providers. Providers who were fee-for-service have switched to concierge only. Now they are taking care of 300 to 500 patients rather than 1,500 to 2,000. It is tough to recruit providers in rural areas.” - Douglas County*

- *“Insurance companies are the gatekeepers to patient access to care instead of providers. It is not an ideal setup and huge problem and is negatively affecting the rural healthcare system.” - Lyon County*



## Substance Use

Substance use is an area of significant concern. Many community members described an increase in the usage of harmful and illicit substances and alcohol in their communities. Service providers noted that there is a lack of services across the spectrum of need, including prevention, treatment, and recovery services.

*“We need substance use disorder prevention. We are working on a substance abuse treatment facility. We haven't had one for 15 years.” - Stakeholder Interviewee*

Organizations are working to combat the increased incidence of substance use while raising awareness and developing prevention programs. There are many barriers that individuals face in seeking treatment for substance use disorders. Community members reported that the facilities have limited capacity.

### According to stakeholders, substance use/misuse is a notable community issue in all service area counties:

- *“Fentanyl is on the rise and being mixed into other substances. It's certainly not getting better.” - Carson City*
- *“Opioids are a big problem here. As first responders, we are starting to see a greater number of calls on opioid overdoses. Alcohol is a major issue here as well, especially with our homeless.” - Carson City*
- *“Alcohol use has gone down in the school system. Pills are a problem - usually oxys or hydrocodone, other opiates. Vaping is out of control.” - Douglas County*
- *“There are a lot of opioids, meth, and Fentanyl. It just seems like everywhere I turn someone is getting poisoned to death.” - Douglas County*
- *“Marijuana gets a little dicey because kids are bringing it to school, and we are seeing a huge increase in violence. Marijuana is laced with other drugs like meth or other stimulants.” - Douglas County*
- *“We are seeing a lot of vaping, not just nicotine. People are using substances to cope.” - Douglas County*
- *“Meth has always been prevalent – cheap, fast, easy to make. Alcohol continues to be an issue.” - Lyon County*
- *“Inmates are frequently mixing meth and heroin together.” - Lyon County*
- *“When you look at our general arrest rates, what they are tied to, and root causes of people seeking social services, it comes down to an unhealthy coping mechanism, which*

*is usually alcohol, which can lead to poly substance use. The severe drug use is concerning meth. Recently we have been seeing more and more opioid use.” -Lyon County*

- *“There is mostly alcohol and marijuana here. We were highest for opioid addiction. We have bars open 24 hours. We don't have a grocery store but have bars.” - Storey County*

**There is a lack of treatment centers and availability for persons with substance use disorder:**

- *“There is an in-patient treatment center in Carson City. They have 20 beds, and the beds aren't always full. There is no addiction in-patient treatment in the other counties.” - Carson City*
- *“All we really have is DHS inpatient substance use disorder treatment center, outpatient therapy, AA groups, and Vitality, but their capacity is very limited so there are really only two treatment centers.” -Carson City*
- *“Reno and Carson City have a few detox facilities but not treatment.” -Carson City*
- *“There is no treatment for substance use. You have to go out of the county or state, around an hour and a half to go to California. In Nevada, there is Reno or Carson which is 20 minutes, but they almost have no availability.” -Douglas County*

## Transportation

Across the Quad-Counties, access to transportation is an area of concern voiced by community stakeholders. Particularly, community members mentioned challenges in accessing transportation to medical appointments and services around the community. Unreliability, timely access, and subpopulation criteria to public transportation were challenges identified in interviews. Public transportation can impact a person’s health and influence health equity. Lack of transportation can cause an individual to miss their health appointments, which can cause poorer health outcomes and added health expenditures. Reliable transportation can improve stability in access to health, nutrition, employment opportunities, and social inclusion.<sup>26</sup>

*“Medical transportation is extremely unreliable. Approximately 70% of the time patients tell us that their ride didn't show and had to cancel for some reason.” - Stakeholder Interviewee*

### The community consensus indicates that transportation is a major barrier to accessing healthcare and community-based services:

- *“A lot of our patients come from Silver Springs, which is 45 minutes away on the highway. We discharge people and then they have to figure out how to get home.” - Carson City*
- *“Transportation for elderly – sometimes they have to sit in the waiting room for hours waiting to be picked up, and they get a timeframe such as a three-hour window and they're just sitting in the waiting room for someone to get them.” - Carson City*
- *“There is no consistent bus system, and we have one taxi driver for lower Douglas County.” – Douglas County*
- *“When we call for hospitals for senior transportation, we schedule strategically. We can’t get any information. Discharges are one of my biggest pet peeves with hospitals. It’s an unsafe discharge.” – Storey County*

### Many communities in the Quad-County Region have transportation that is exclusive to pockets of the community, and/or requires specific criteria:

- *“We have very poor transportation. With DART we need to set up appointments between nine and two and you need to fill out the application with the healthcare provider.” - Carson City*

<sup>26</sup> Health Affairs. Culture of Health: Public Transportation in the US, 2021  
<https://www.healthaffairs.org/doi/10.1377/hpb20210630.810356/full/health-affairs-brief-public-transportation-health-equity-heaps.pdf>

## QUAD-COUNTY REGIONAL COMMUNITY HEALTH NEEDS ASSESSMENT

- *“I have a friend who is terminal and has no transportation; a lot of services have closed down. DART doesn’t go to the hospital.” - Carson City*
- *“We do transportation through Lyon County Services; our Monday, Wednesday, and Friday bus – we refer to it as the dialysis bus. It is packed full of patients going to Reno to see two providers there. The other lines are pretty restrictive.” - Lyon County*
- *“There is no transportation in Douglas County other than DART. It runs 9 am until 1 pm and is only for doctor’s appointments, and you need to call three days in advance. There’s a limited number of drivers. With COVID, we had limited capacity.” - Douglas County*
- *We have SAFE transportation for the elderly. Most transportation goes North to Reno and not the other way. Some don’t allow oxygen, wheelchairs, walkers. We are working on getting a van for a clinic, but we can’t find someone to drive the van. When we find someone, they will be immediately full and we would need multiple vans. - Douglas County*

## Potential Solutions

At the end of the interview, community stakeholders were asked the “magic wand” question: “If you had all the money and access to resources in the world, what is one thing you would do to make your community a better place?” Many stakeholders shared potential solutions to enhance access to services and increase opportunities for social connectivity.

- *“We need to increase our funds so when we have a patient that comes in without money then we can pay for some of their services (i.e., blood work).”*
- *“Some form of a clinic or even a mobile clinic would be helpful with the growth of the county.”*
- *“We need a resource guide that has all the answers for people so they know where to go for resources and services.”*
- *“A place where someone could go with their needs and get help such as a resource center equipped with wraparound services and an information hub.”*
- *“For those who are incarcerated if we could offer drug and alcohol rehab as part of their incarceration it would be a benefit.”*
- *“I would put in robust eldercare programs- long-term care, nursing homes, and assisted living independent living cottages.”*
- *“Senior citizens I feel like they are active at senior centers and clubs but there needs to be different programs that are offered to them.”*
- *“We need more English classes. We used to have an ESL program but we don't have mentors. The ESL program is restricted by grant conditions. For example, there were college students teaching ESL classes but the grant says that if there are not a minimum of 10 students then they can't teach the class.”*
- *“We have no further adult education programs so something of that nature would be nice.”*
- *“As far as the kid population if we could offer an explorer program so they can learn about life and develop skills. It would be really great to see more facilities and jobs do junior training programs. They help them apply for colleges but they don't set them up for adulting. If we took more time doing that then we would have more successful kids.”*
- *“I think there could be a variety of activities youth and adult sports. There are no adult recreation leagues and the youth leagues are run locally but sporadically.”*
- *“We need opportunities for all ages to come together with an emphasis on healthy interactive exchanges such as arts and activities for children and families.”*

## Quantitative Community Survey

The Community Survey enabled a greater share of community residents across the Quad-County Region to share their perspectives on the unique challenges, barriers, and possible solutions to healthcare and social service access, and other community needs.

### Survey Methodology

Two survey methods – telephone and online – were deployed in the community to further capture the insights of community residents. Each survey results supplement other primary research activities – focus groups, interviews, access audit, and others – and provide an empirical perspective on key project issues. Specifically, the confidential survey helped to further identify community members’ perspectives and opinions about community health needs, currently available resources, services that should be added or modified, and ways to help communities receive the care they need.

### Online Community Survey

The community survey was made available via online and paper questionnaires, and it was offered in two languages, English and Spanish. The questionnaire included closed-ended, need-specific evaluation questions; open-ended questions; and demographic questions. There were 1,551 survey responses from individuals living in Carson City, Douglas, Lyon, or Storey counties, including 706 responses from those in Carson Tahoe Health service area ZIP codes.

Special care was exercised to minimize the amount of non-sampling error by careful assessment of design effects (e.g., question order, question wording, response alternatives). The survey was conducted to maximize accessibility and comprehensively evaluate community members’ insights. The community survey had 28 numbered questions and 68 sub-questions, while the telephone survey had 12 questions and 30 sub-questions. Sub-questions include requests to rate each community health need listed on a five-point scale. See appendix for each survey instrument.

Invitations to participate were provided to the community through e-mails from the CHNA project partners, among others in each county. Community partners disseminated the survey through a wide variety of channels, including websites, social media, and email.

### Telephone Survey

During late July 2022, a random-digital telephone survey was conducted of 400 community residents across the Quad-County Region service area. The survey consisted of 42 questions. It was a modified, scaled-down version of the online community survey.

## Community Survey Demographics

Among respondents to the community survey (n=1,551), one in two (47.8%) live in Carson City. Nearly one-third of respondents (32.2%) are younger than age 35, with half (50.9%) falling between the ages of 35 and 55. Nearly two in three respondents (63.8%) identify as male, and the vast majority of respondents (91.0%) are heterosexual. Most respondents (90.8%) identify as White or Caucasian, and better than one in eight (13.2%) identify as Hispanic, Latino, or other Spanish origin. Nearly four in five (78.1%) reported total annual household income of less than \$65,000.

**Exhibit 29: Community Survey Respondent Demographics**

DEMOGRAPHIC VARIABLE	Percent of Community Survey Respondents
<b>COUNTY</b>	
Carson City	47.8% (n=742)
Lyon County	17.8% (n=276)
Douglas County	27.4% (n=425)
Storey County	7.0% (n=108)
<b>AGE<sup>^</sup></b>	
18-24	1.9%
25-34	30.3%
35-44	28.4%
45-54	22.5%
55-64	7.5%
65-74	7.2%
75 and older	2.2%
<b>GENDER IDENTITY</b>	
Female	34.1%
Male	64.1%
Gender non-binary	0.5%
Transgender female	0.8%
Transgender male	0.5%
<b>RACE<sup>+</sup></b>	
White or Caucasian	90.8%
Another race	1.4%
American Indian or Alaska Native	3.0%
Black or African American	2.1%
Asian	2.6%

DEMOGRAPHIC VARIABLE	Percent of Community Survey Respondents
Native Hawaiian or other Pacific Islander	0.7%
<b>ETHNICITY</b>	
Hispanic, Latino, or other Spanish origin	13.2%
Not Hispanic Latino, or other Spanish origin	86.8%
<b>ANNUAL HOUSEHOLD INCOME</b>	
Under \$15,000	1.1%
\$15,000-\$24,999	3.2%
\$25,000-\$34,999	21.8%
\$35,000-\$74,999	57.3%
\$75,000-\$99,999	5.8%
\$100,000 and above	10.8%

<sup>^</sup> Population age 18 and older only

<sup>+</sup> Survey instruction to 'check all that apply'



## Community Survey Findings

The survey results yielded frequency tables and cross tabulations, which are survey responses sorted by age group, income, or other respondent categories, for all survey questions.

### Routine Care

Most individuals in the Quad-County Region indicated that they have a family doctor or place where they get routine care. While the majority of respondents reported having a family doctor or place to go for routine care, the use of emergency rooms for such care was greater among younger respondents. There is minimal reported difference between those with household income less than \$55,000 and those with household income of \$55,000 or more with regard to having a family doctor or other source of routine care.

**Exhibit 30: Do you have a family doctor or a place where you go for routine care?**

	Carson City	Douglas County	Lyon County	Storey County	CTH PSA	Total
Yes, family doctor, family health center, or clinic	93.1%	81.6%	80.7%	81.5%	91.8%	<b>86.9%</b>
Yes, emergency room	2.3%	9.7%	8.2%	13.0%	0.7%	<b>6.1%</b>
Yes, walk-in urgent care	1.4%	3.6%	5.2%	4.6%	2.1%	<b>2.9%</b>
No	3.2%	5.1%	5.9%	0.9%	5.4%	<b>4.0%</b>

**Exhibit 31: Do you have a family doctor or a place where you go for routine care?**

	Younger than 35	35 to 54	55 and older	Total
Yes, family doctor, family health center, or clinic	80.8%	89.1%	93.8%	87.2%
Yes, emergency room	12.3%	5.8%	0.0%	6.9%
Yes, Walk-in urgent care	3.8%	2.1%	2.8%	2.8%
No	3.1%	3.0%	3.3%	3.1%

- Overall, 87.2% of respondents reported going to a family doctor, family health center, or clinic for routine care, ranging from 93.8% of those age 55 and older to 80.8% of those younger than 35.

**Exhibit 32: Do you have a family doctor or a place where you go for routine care?**

	Less than \$55,000	\$55,000 or more	Total
Yes, family doctor, family health center, or clinic	87.1%	87.0%	<b>87.1%</b>
Yes, emergency room	8.2%	6.0%	<b>7.2%</b>
Yes, Walk-in urgent care	2.9%	2.6%	<b>2.8%</b>
No	1.8%	4.4%	<b>2.9%</b>

### Occasions When Not Getting Needed Care

It was common for people in the service area to have unmet medical or mental health needs. Respondents noted that their primary reason for not seeking care was lack of money, but also cited wait times and comfort with the providers as barriers. Respondents aged 55 and older were far less likely to report one or more occasions where they needed care but chose not to get it. Among those younger than age 55, the most common reasons for not getting needed care were lack of money or ability to pay, and/or not feeling comfortable with available providers. Those with income less than \$55,000 were more likely to report one or more occasions in the past two years when they needed care but chose not to get it (87.1% vs. 66.7%).

**Exhibit 33: In the past two years, has there been one or more occasions when you needed medical or mental healthcare but chose NOT to get it?**

	Carson City	Douglas County	Lyon County	Storey County	CTH PSA	Total
Yes	74.2%	64.2%	74.2%	95.4%	54.9%	<b>73.0%</b>
No	25.8%	35.8%	25.8%	4.6%	45.1%	<b>27.0%</b>

- 73% of respondents indicated that there had been one or more occasions in which they did not seek care in the past two years.  
95.4% of respondents from Storey County indicated that there had been one or more occasions in which they did not seek care in the past two years

**Exhibit 34: In the past two years, has there been one or more occasions when you needed medical or mental healthcare but chose NOT to get it?**

	Younger than 35	35 to 54	55 and older	Total
Yes	86.1%	84.2%	31.5%	75.9%
No	13.9%	15.8%	68.5%	24.1%

**Exhibit 35: In the past two years, has there been one or more occasions when you needed medical or mental healthcare but chose NOT to get it?**

	Less than \$55,000	\$55,000 or more	Total
Yes	87.1%	66.7%	<b>78.0%</b>
No	12.9%	33.3%	<b>22.0%</b>

## Reasons for Not Getting Needed Care

Beyond lack of money, wait times, and comfort with providers, nearly two in five respondents selected lack of provider cultural competency (18.4%) and/or COVID-19 restrictions (18.2%) as reasons for not seeking care. Other responses selected by more than one in seven included lack of health insurance (17.3%), lack of provider knowledge about sexual orientation or gender status (16.6%), provider language spoken (15.5%), and distance from home to doctor's office (14.8%). More than eight in 10 respondents younger than age 55 reported not getting needed care, compared to fewer than one in three respondents aged 55 or older (31.5%).

Interestingly, among those with household income of \$55,000 or more, a greater proportion reported lack of money/ability to pay as the reason they did not get needed care (27.6% vs. 22.9%). Among those with less than \$55,000 in household income, the most common reason for not seeking care was lack of comfort with available providers (23.0%). The higher income group was more likely to report long wait times and/or issues with COVID-19 related restrictions, while the lower income group was more likely to report provider lack of knowledge about people with their sexual orientation or gender status.

**Exhibit 36: Reason for Note Getting Need Care by Geography**

	Carson City	Douglas County	Lyon County	Storey County	CTH PSA	Total
Lack of money/ability to pay	24.3%	26.2%	26.4%	19.4%	34.0%	<b>24.7%</b>
Long wait times to see a provider	22.2%	27.3%	22.9%	13.6%	33.2%	<b>22.8%</b>
Did not feel comfortable with available providers	21.3%	19.9%	28.9%	25.2%	21.7%	<b>22.7%</b>
Providers are not culturally competent	16.4%	17.6%	22.9%	22.3%	12.0%	<b>18.4%</b>
COVID-19 related restrictions	16.5%	19.9%	19.9%	19.4%	17.3%	<b>18.2%</b>
Lack of health insurance	19.3%	11.6%	18.4%	19.4%	15.2%	<b>17.3%</b>
Providers not knowledgeable about people with my sexual orientation or gender status	14.9%	16.9%	16.9%	24.3%	11.5%	<b>16.6%</b>
Providers did not speak my language	16.4%	15.0%	12.9%	17.5%	9.9%	<b>15.5%</b>
Doctor's office is too far from my house	14.3%	10.9%	17.9%	21.4%	10.7%	<b>14.8%</b>
Concern about my immigration status	13.8%	12.0%	14.9%	19.4%	8.4%	<b>14.1%</b>
Lack of transportation	11.6%	9.4%	15.4%	13.6%	10.5%	<b>11.9%</b>
I don't like the providers	2.0%	1.5%	4.0%	2.9%	5.0%	<b>2.3%</b>

- Approximately 28.9% of Lyon County respondents and 25.2% of Storey county respondents indicated that they did not feel comfortable with available providers, which was well above Carson City’s 15.6% and Douglas County’s 12.5% of respondents.
- Conversely, the proportions of respondents from CTH service area were lower than other respondents in most cases, with the exception of lack of money/ability to pay (34.0%) and long wait times to see a provider (33.2%), each of which were above the overall figures (24.7% and 22.8%, respectively).

**Exhibit 3: Reasons for Not Getting Needed Care by Age Group**

	Younger than 35	35 to 54	55 and older	Total
Lack of money/ability to pay	27.5%	22.3%	29.0%	24.7%
Did not feel comfortable with available providers	23.9%	22.0%	18.8%	22.5%
Long wait times to see a provider	17.8%	20.7%	59.4%	22.4%
Providers are not culturally competent	20.0%	20.2%	10.1%	19.4%
Providers not knowledgeable about people with my sexual orientation or gender status	21.7%	16.8%	5.8%	17.8%
COVID-19 related restrictions	15.3%	19.1%	20.3%	17.8%
Lack of health insurance	18.6%	18.6%	4.3%	17.6%
Providers did not speak my language	18.1%	16.8%	1.4%	16.2%
Doctor's office is too far from my house	15.3%	15.5%	11.6%	15.1%
Concern about my immigration status	14.7%	16.2%	1.4%	14.6%
Lack of transportation	12.2%	13.2%	8.7%	12.5%
I don't like the providers	2.5%	1.1%	4.3%	1.8%

- Among those younger than age 55, lack of money/ability to pay and/or lack of comfort with available providers were the two most common reasons for not getting needed care, selected by more than one in five respondents in each case. Provider lack of knowledge about sexual orientation or gender status was also a common reason identified by those younger than 35 (21.7%).
- The most common reason for not getting care about those 55 and older, by far, was long wait times to see a provider (59.4%). The second most common reason was lack of money/ability to pay (29.0%).

**Exhibit 38: Reason for Not Getting Needed Care by Income**

Reason for Not Getting Needed Care by Income	Less than \$55,000	\$55,000 or more	Total
Lack of money/ability to pay	22.9%	27.6%	<b>24.7%</b>
Did not feel comfortable with available providers	23.0%	22.0%	<b>22.6%</b>
Long wait times to see a provider	17.6%	27.4%	<b>21.4%</b>
Providers are not culturally competent	21.2%	17.6%	<b>19.8%</b>

Reason for Not Getting Needed Care by Income	Less than \$55,000	\$55,000 or more	Total
Providers not knowledgeable about people with my sexual orientation or gender status	20.3%	14.6%	<b>18.2%</b>
Lack of health insurance	18.3%	17.6%	<b>18.0%</b>
COVID-19 related restrictions	15.6%	20.6%	<b>17.5%</b>
Providers did not speak my language	17.1%	15.7%	<b>16.6%</b>
Doctor's office is too far from my house	15.5%	15.7%	<b>15.6%</b>
Concern about my immigration status	16.6%	12.2%	<b>14.9%</b>
Lack of transportation	14.5%	9.8%	<b>12.7%</b>
I don't like the providers	1.8%	1.9%	<b>1.9%</b>

## Community Profile

The following question was presented in the survey: *“Thinking about Community Health, please rate each statement below on a scale of 1 (strongly disagree) to 5 (strongly agree).”* The exhibit below shows the percentage of respondents who chose either *“Disagree”* or *“Strongly Disagree”*. Overall, a minority of respondents disagreed or strongly disagreed with statements about their community’s ability to improve its health. Respondents aged 55 and older disagreed or strongly disagreed less often than younger respondents with statements regarding their community’s ability to work to improve health. Those with household income of less than \$55,000 were more likely to disagree with statements about their community’s ability to work to improve health and make positive change.

**Exhibit 39: Ranking Community Health, please rate each statement.**

PERCENT "DISAGREE" OR "STRONGLY DISAGREE"	Carson City	Douglas County	Lyon County	Storey County	CTH PSA	Total
My community can work together to improve its health	24.6%	23.2%	28.2%	30.2%	18.3%	<b>25.3%</b>
My community has the resources to improve its health	35.3%	29.6%	40.6%	32.1%	34.2%	<b>34.5%</b>
My community works together to make positive change for health	37.2%	31.9%	33.7%	35.2%	32.5%	<b>35.0%</b>
I know my neighbors will help me stay healthy	42.2%	30.2%	38.4%	32.1%	42.9%	<b>37.6%</b>

- Across counties, more respondents disagreed that their community works together to make positive change for health (35.0% overall) than disagreed that their community can work together to improve its health (25.3% overall).
- 40.6% of respondents from Lyon County disagreed that their community has the resources to improve its health, compared to just 29.6% of respondents in Douglas County.

**Exhibit 40: Rating of Community Health Indicators**

Percent who “Disagree” or “Strongly Disagree”	Younger than 35	35 to 54	55 and older	Total
My community can work together to improve its health	29.1%	30.1%	6.4%	<b>25.8%</b>
My community has the resources to improve its health	34.8%	38.4%	22.8%	<b>34.6%</b>
My community works together to make positive change for health	39.3%	36.3%	24.3%	<b>35.3%</b>
I know my neighbors will help me stay healthy	37.1%	39.8%	35.0%	<b>38.1%</b>

- While one in four respondents disagreed that their community could work together to improve itself, more than one in four of those younger than age 55 disagreed with this statement, compared to only 6.4% of those age 55 and older.
- For three out of the four statements, respondents aged 35 to 54 were most likely of any group to disagree, and those age 55 and older were least likely to disagree.

**Exhibit 41: Rating of Community Health Indicators**

Percent who “Disagree” or “Strongly Disagree”	Less than \$55,000	\$55,000 or more	Total
My community can work together to improve its health	30.4%	21.8%	<b>26.6%</b>
My community has the resources to improve its health	35.5%	34.2%	<b>34.9%</b>
My community works together to make positive change for health	35.9%	34.2%	<b>35.2%</b>
I know my neighbors will help me stay healthy	39.4%	36.3%	<b>38.0%</b>

## Community Engagement & Belonging

Across counties, respondents reported belonging to a variety of groups and organizations. In the CTH service area, one in five respondents (20.1%) reported not belonging to any of the groups listed in the table above. In other counties, this ranged from 1.9% (Storey County) to 14.4% (Douglas County). Those with household income less than \$55,000 were more likely to report belonging to a social organization and/or neighborhood association or club, while those with household income of \$55,000 or greater were more likely to belong to a volunteer group, church, temple or religious group, or professional or trade organization.

**Exhibit 4: Do you belong to any of the following in the community?**

	Carson City	Douglas County	Lyon County	Storey County	CTH PSA	Total
Volunteer group	18.1%	17.9%	15.2%	16.7%	16.0%	<b>17.4%</b>
Church, temple, or religious group	18.1%	14.8%	12.7%	11.1%	18.7%	<b>15.7%</b>
Social organization (such as Lions Clubs, Masonic organizations, etc.)	12.3%	16.7%	17.8%	26.9%	10.6%	<b>15.5%</b>
Professional or trade organizations	13.5%	15.5%	15.6%	22.2%	14.4%	<b>15.0%</b>
School, university, technical training, or adult education	15.8%	12.5%	13.4%	16.7%	12.3%	<b>14.5%</b>
Recreational or sports club or team	11.3%	12.9%	13.0%	16.7%	10.3%	<b>12.4%</b>
Neighborhood association or club	10.0%	11.8%	12.7%	19.4%	6.8%	<b>11.6%</b>
Youth-focused organizations or groups (such as Cub Scouts, Girl Scouts, PTA, Gay Straight Alliance, etc.)	3.1%	3.8%	6.2%	10.2%	4.4%	<b>4.3%</b>
Other (please specify)	3.4%	1.9%	0.4%	0.9%	4.2%	<b>2.3%</b>
None of the above	9.6%	14.4%	12.3%	1.9%	20.1%	<b>10.8%</b>

- Only 1.9% of respondents in Storey County chose none of the above, and had more individuals involved in youth-focused organizations at 10.2% than Douglas County, 3.8%, and Carson City, 3.1%, combined. The other most popular affiliations were social organizations and professional or trade organizations in Storey County (26.9% and 22.2% of respondents, respectively), volunteer groups in Carson City and Douglas County (18.1% and 17.9%, respectively), and social organizations in Lyon County (17.8%).



**Exhibit 43: Do you belong to any of the following in the community?**

	Less than \$55,000	\$55,000 or more	Total
Volunteer group	16.7%	24.0%	<b>19.9%</b>
Social organization (such as Lions Clubs, Masonic organizations, etc.)	19.9%	16.6%	<b>18.4%</b>
Church, temple, or religious group	14.6%	21.4%	<b>17.7%</b>
Professional or trade organizations	14.8%	21.1%	<b>17.6%</b>
School, university, technical training, or adult education	16.2%	18.9%	<b>17.4%</b>
Recreational or sports club or team	14.8%	15.0%	<b>14.9%</b>
Neighborhood association or club	15.8%	10.6%	<b>13.5%</b>
Youth-focused organizations or groups (such as Cub Scouts, Girl Scouts, PTA, Gay Straight Alliance, etc.)	3.2%	6.8%	<b>4.8%</b>
Other	1.0%	3.6%	<b>2.2%</b>
None of the above	8.6%	12.6%	<b>10.4%</b>

## Social Connectedness

Across geographies, no fewer than one in five respondents, and most commonly, at least one in three respondents, reported that the various types of support listed below were available to them “none” or “a little of the time.” Members of the lower income group were more likely to report having the supports listed below ‘none’ or ‘a little of the time’ compared to those from the higher income group.

**Exhibit 44: How often is each of the following kinds of support available to you if you need it?**

PERCENT SAYING, "NONE" OR "A LITTLE OF THE TIME"	Carson City	Douglas County	Lyon County	Storey County	CTH PSA	Total
Someone you can count on to listen to you when you need to talk	35.1%	28.0%	34.6%	38.6%	21.6%	<b>33.4%</b>
Someone to give you information to help you understand a situation	34.5%	31.3%	38.3%	44.6%	26.3%	<b>35.1%</b>
Someone to confide in or talk to about yourself or your problems	34.0%	30.3%	34.7%	38.6%	26.7%	<b>33.5%</b>
Someone to turn to for suggestions about how to deal with a personal problem	35.3%	30.2%	39.0%	43.6%	25.8%	<b>35.3%</b>
Someone to help you if you were confined to bed	36.8%	34.2%	41.7%	39.6%	30.7%	<b>37.2%</b>
Someone to take you to the doctor if you needed it	34.3%	32.1%	36.6%	36.6%	25.9%	<b>34.3%</b>
Someone to help with daily chores if you were sick	36.3%	34.6%	34.0%	38.6%	30.1%	<b>35.6%</b>
Someone who hugs you	39.5%	29.1%	35.0%	48.5%	23.9%	<b>36.7%</b>
Someone to love and make you feel wanted	35.9%	31.5%	36.3%	38.6%	26.0%	<b>35.0%</b>
Someone to get together with for relaxation	35.9%	28.7%	30.4%	44.6%	25.6%	<b>33.7%</b>
Someone to do something enjoyable with	33.5%	30.9%	30.4%	38.0%	26.0%	<b>32.6%</b>

- A smaller percentage of respondents from the CTH service area responded that the supports listed below were available to them “none” or “a little of the time” than other respondents. Among those from the CTH service area, these percentages ranged from 21.6% to 30.7% of respondents. Across the other geographies, these percentages ranged from 28.0% to 48.5% of respondents.

- Overall, the largest proportion of respondents (37.2%) reported that they did not have someone to help them if they were confined to bed, ranging from 41.7% of those in Lyon County to 30.7% of those in the CTH service area.
- In all cases, those in Storey County had the highest proportion of responses of “none” or “a little of the time” with regard to the identified supports.

**Exhibit 45: People sometimes look to others for companionship, assistance, or other types of support. How often is each of the following kinds of support available to you if you need it?**

PERCENT SAYING, "NONE" OR "A LITTLE OF THE TIME"	Less than \$55,000	\$55,000 or more	Total
Someone who hugs you	44.0%	31.2%	<b>38.2%</b>
Someone to help you if you were confined to bed	44.0%	30.9%	<b>38.1%</b>
Someone to help with daily chores if you were sick	43.3%	28.4%	<b>36.6%</b>
Someone to love and make you feel wanted	41.7%	30.1%	<b>36.5%</b>
Someone to turn to for suggestions about how to deal with a personal problem	42.4%	28.2%	<b>36.0%</b>
Someone to give you information to help you understand a situation	44.7%	25.1%	<b>35.9%</b>
Someone to take you to the doctor if you needed it	41.8%	28.5%	<b>35.9%</b>
Someone to get together with for relaxation	39.9%	28.7%	<b>34.9%</b>
Someone to confide in or talk to about yourself or your problems	40.1%	27.5%	<b>34.4%</b>
Someone you can count on to listen to you when you need to talk	41.2%	26.1%	<b>34.4%</b>
Someone to do something enjoyable with	40.5%	25.4%	<b>33.7%</b>

## Pelvic Pain

While proportions of those identifying as a woman or someone with a uterus, and among this group, those experiencing pelvic pain, were variable across geography, the majority of those experiencing pain reported having access to resources, medical treatment, and support.

**Exhibit 46: Do you belong to any of the following in the community?**

	Carson City	Douglas County	Lyon County	Storey County	CTH PSA	Total
Do you identify as a woman or someone with a uterus?	34.5%	59.5%	46.8%	31.0%	59.7%	<b>43.0%</b>
Do you currently experience pain in your pelvis that has recurred for over six months? (Percent experiencing pain)	21.9%	30.8%	42.0%	74.2%	12.5%	<b>31.9%</b>
Do you have access to adequate community resources, medical treatment, and support for your pain? (Percent of those experiencing pain)	83.3%	88.5%	86.8%	91.3%	74.2%	<b>87.2%</b>
Have you ever been pregnant? (Percent of those who are, or have been, pregnant)	75.2%	79.4%	89.2%	76.7%	76.9%	<b>79.6%</b>

- Fewer than half of respondents (43.0%) identified as a woman or someone with a uterus, ranging from 59.7% of those in the CTH service area to 31.0% of those from Storey County.
- Among women, fewer than half (31.9%) reported experiencing current pelvic pain that has recurred for over six months. This ranged from 12.5% of those in the CTH service area to 74.2% of those in Storey County.
- Most respondents (87.2%) who reported experiencing pain also reported having access to community resources, medical treatment, and support for their pain. This percentage was lower in the CTH service area, where fewer than three in four respondents (74.2%) reported having access to such resources, treatment, and support.
- Nearly four in five women surveyed (79.6%) reported having ever been pregnant, including 89.2% of those in Lyon County.

The age distribution of respondents to the question about pelvic pain varied considerably across CTH and non-CTH zip codes.

## Other Reproductive Health Issues

Relatively few respondents who identify as women or having a uterus reported challenges accessing reproductive care in their area, with consistent differences across geographies.

**Exhibit 47: In the past two years, have you had any challenges accessing any of the following associated reproductive care in your location?**

PERCENT OF WOMEN SAYING, "YES"	Carson City	Douglas County	Lyon County	Storey County	CTH PSA	Total
Birth control	9.4%	15.8%	19.1%	35.5%	4.9%	<b>15.0%</b>
Menopause support and education	7.2%	12.4%	10.0%	19.4%	8.3%	<b>10.3%</b>
Postpartum care with a medical provider	6.3%	9.1%	15.5%	9.7%	2.4%	<b>9.2%</b>
Fertility treatments	5.4%	7.2%	10.0%	35.5%	2.8%	<b>8.6%</b>
STI testing and/or treatment	4.0%	9.6%	9.1%	29.0%	2.4%	<b>8.4%</b>
Abortion	4.9%	6.2%	11.8%	22.6%	2.4%	<b>7.7%</b>
Prenatal care with a medical provider	5.8%	4.8%	10.0%	16.1%	1.5%	<b>6.8%</b>
Sexual violence or rape support	4.0%	0.0%	1.8%	6.5%	1.8%	<b>2.3%</b>
Other	8.5%	9.1%	8.2%	0.0%	11.3%	<b>8.2%</b>

- The greatest overall percentage of respondents (15.0%) reported having challenges accessing birth control, including one in three of those from Storey County (35.5%).

The percentage of women living in a CTH PSA zip code who answered 'Yes' to questions about experiencing challenges accessing various reproductive health care services in the past two years was consistently lower than the corresponding percentage of women who did not report living in a CTH PSA zip code. For example, for the question about experiencing challenges accessing care related to birth control, two-thirds of respondents (65.8%) reported living in a CTH PSA zip code, but respondents from these zip codes accounted for only one in five 'Yes' responses (20.9%). An important difference between respondents identifying as women (or someone with a uterus) is that the sample of respondents from the CTH PSA zip codes reported being older than those not from these zip codes. More than four in ten women from a CTH PSA (43.3%) reported being age 55 and older, compared to fewer than two in ten (18.6%) of those not from these zip codes. Given that the content of this series of questions largely covers current or recent experiences related to child-bearing, it is reasonable to expect the sample of older respondents from CTH PSA to respond less affirmatively regarding experiencing these issues in the recent past (i.e., within the past two years) than the sample of younger respondents from non-CTH PSA zip codes.

## Unmet Health Needs

Nearly three in four respondents (73.7%) reported that they or their family did not have unmet mental health or substance abuse needs, and this percentage was lower in Douglas, Lyon, and Storey counties. Respondents younger than age 35 were most likely to identify that they or their family have unmet mental health or substance abuse needs. Those with household income of less than \$55,000 were slightly more likely to report having an unmet mental health or substance use need themselves (9.6% vs. 6.7%).

### Exhibit 48: Do you or your family currently have unmet mental health or substance abuse needs? (Reported by County)

	Carson City	Douglas County	Lyon County	Storey County	CTH PSA	Total
Yes, I have an unmet need	5.6%	11.3%	10.1%	9.9%	7.0%	8.2%
Yes, an adult family member has an unmet need	7.4%	14.7%	17.1%	18.9%	10.8%	12.0%
Yes, a child family member has an unmet need	4.2%	6.8%	8.5%	9.9%	5.8%	6.1%
No	82.9%	67.2%	64.3%	61.3%	76.3%	73.7%

- One in three respondents from Douglas, Lyon, or Storey counties reported that they or their family had unmet mental health or substance abuse needs, compared to fewer than one in four of those in Carson City or the CTH service area.
- Storey County featured the greatest proportion of respondents reporting adult or child family members with unmet needs, 19.9% and 9.9%, respectively.

### Exhibit 49: Do you or your family currently have unmet mental health or substance abuse needs? (Reported by Age)

	Younger than 35	35 to 54	55 and older	Total
Yes, I have an unmet need	12.6%	6.2%	4.1%	<b>7.9%</b>
Yes, an adult family member has an unmet need	16.5%	9.8%	10.0%	<b>12.0%</b>
Yes, a child family member has an unmet need	6.7%	6.7%	2.7%	<b>6.0%</b>
No	64.0%	80.2%	75.3%	<b>74.1%</b>

- Three in 10 respondents younger than age 35 reported that they or a family member has an unmet need, compared to fewer than two in 10 respondents aged 35 or older.
- Respondents younger than 35 were most likely to report that they had an unmet need (12.6%) or that an adult family member has an unmet need (16.5%).

**Exhibit 50: Do you or your family currently have unmet mental health or substance abuse needs? (Reported by Income)**

	Less than \$55,000	\$55,000 or more	Total
Yes, I have an unmet need	9.6%	6.7%	<b>8.3%</b>
Yes, an adult family member has an unmet need	11.5%	13.5%	<b>12.4%</b>
Yes, a child family member has an unmet need	5.8%	6.8%	<b>6.3%</b>
No	74.9%	72.8%	<b>73.9%</b>

## Impact of COVID-19

More than one in five respondents reported challenges stemming from the past two years, with respondents from the CTH service area consistently reporting the lowest levels of these issues as common or more frequent challenges. Greater proportions of respondents younger than age 55 report such challenges compared with those age 55 and older. More of those with household income less than \$55,000 reported struggling daily or experiencing common challenges with the variety of issues listed below, as compared to the higher income group.

**Exhibit 51: The past two years have been a challenge for all of us. Currently, are you having any challenges with the following? (Reported by County)**

PERCENT SAYING THAT THIS IS A "COMMON" OR MORE FREQUENT CHALLENGE	Carson City	Douglas County	Lyon County	Storey County	CTH PSA	Total
Feeling lonely	37.4%	31.6%	34.9%	46.1%	28.7%	<b>36.1%</b>
Enjoying leisure activities	36.2%	33.9%	34.3%	40.6%	26.3%	<b>35.6%</b>
Managing major life issues such as relationship challenges, relocating, new job or change of school, loss of a loved one, or major illness	35.1%	34.1%	34.8%	34.3%	24.7%	<b>34.7%</b>
Establishing and maintaining trusted relationships	34.8%	28.5%	33.7%	38.2%	25.1%	<b>33.2%</b>
Getting along with people at work or in the community	32.2%	28.8%	33.3%	38.6%	21.9%	<b>32.0%</b>
Getting along well with friends and family members	35.3%	26.3%	26.5%	39.6%	20.8%	<b>31.7%</b>
Performing well at school or work	33.3%	25.4%	30.0%	46.9%	20.6%	<b>31.7%</b>
Regular living activities such as getting to school or work on time, grocery shopping, or doing other common tasks	32.5%	24.6%	33.2%	42.2%	20.8%	<b>31.3%</b>

- Overall, the greatest proportion of respondents (36.1%) reported that feeling lonely was a common or more frequent challenge, while the smallest proportion (31.3%) reported challenges with regular living activities such as getting to school or work on time, grocery shopping, or doing other common tasks.
- The greatest proportions of respondents reporting challenges in the areas above were found in Storey County, ranging from 46.9% (performing well at school or work) to 34.3% (managing major life issues such as relationship challenges, relocating, new job or change of school, loss of a loved one, or major illness).



- The smallest proportions of respondents reporting challenges were found in the CTH service area, ranging from 28.7% in “feeling lonely” to 20.6% in “performing well at school or work”.

**Exhibit 52: The past two years have been a challenge for all of us. Currently, are you having any challenges with the following? (Reported by Age)**

	Younger than 35	35 to 54	55 and older	Total
Feeling lonely	41.5%	40.7%	14.6%	<b>36.6%</b>
Enjoying leisure activities	41.2%	39.1%	15.7%	<b>35.8%</b>
Managing major life issues such as relationship challenges, relocating, new job or change of school, loss of a loved one, or major illness	42.1%	38.9%	9.5%	<b>35.1%</b>
Establishing and maintaining trusted relationships	39.0%	37.1%	11.6%	<b>33.5%</b>
Getting along with people at work or in the community	38.5%	37.7%	3.8%	<b>32.4%</b>
Performing well at school or work	36.2%	39.1%	2.0%	<b>32.3%</b>
Getting along well with friends and family members	37.0%	37.2%	6.9%	<b>32.1%</b>
Regular living activities such as getting to school or work on time, grocery shopping, or doing other common tasks	36.6%	36.3%	7.9%	<b>31.7%</b>

- More than four in 10 respondents younger than age 35 report feeling lonely (41.5%), enjoying leisure activities (41.2%), and/or managing major life issues such as relationship challenges, relocating, new job or change of school, loss of a loved one, or major illness (42.1%).
- Respondents aged 35 to 54 most commonly report feeling lonely (40.7%) and least commonly report challenges with regular living activities such as getting to school or work on time, grocery shopping, or doing other common tasks (36.3%).
- Respondents aged 55 and older most commonly report challenges enjoying leisure activities (15.7%) and/or feeling lonely (14.6%).

**Exhibit 53: The past two years have been a challenge for all of us. Currently, are you having any challenges with the following? (Reported by Income)**

Percent reporting 'I struggle with this issue daily' or 'This is a common challenge for me'	Less than \$55,000	\$55,000 or more	Total
Feeling lonely	44.8%	28.9%	<b>37.7%</b>
Enjoying leisure activities	42.5%	29.0%	<b>36.4%</b>
Managing major life issues such as relationship challenges, relocating, new job or change of school, loss of a loved one, or major illness	42.1%	28.5%	<b>36.0%</b>
Establishing and maintaining trusted relationships	40.1%	28.0%	<b>34.6%</b>
Getting along with people at work or in the community	41.3%	24.2%	<b>33.7%</b>
Performing well at school or work	40.9%	24.3%	<b>33.4%</b>
Getting along well with friends and family members	39.6%	25.5%	<b>33.3%</b>
Regular living activities such as getting to school or work on time, grocery shopping, or doing other common tasks	38.1%	25.5%	<b>32.5%</b>

## Community Survey Prioritized Needs Results

Overall, respondents prioritized access to safe, affordable housing, counseling services for mental health issues for adults and adolescents/children, affordable quality childcare, and affordable prescription drugs as issues that need more attention for improvement. A full table of all ranked needs is available in Appendix I.

**Exhibit 54: Which of the following community and health-related issues do you feel need more attention for improvement?**

Rank	Carson City	Douglas County	Lyon County	Storey County	CTH Service Area	Total
1	Access to safe, affordable housing	Counseling services for mental health issues such as depression, anxiety, and others for adults	Access to safe, affordable housing	Access to clean, public places to play and exercise	Counseling services for mental health issues such as depression, anxiety, and others for adolescents/children	Access to safe, affordable housing
2	Counseling services for mental health issues such as depression, anxiety, and others for adults	Counseling services for mental health issues such as depression, anxiety, and others for adolescents/children	Affordable healthcare services for individuals or families with low income	Opportunities for physical fitness	Access to safe, affordable housing	Counseling services for mental health issues such as depression, anxiety, and others for adults
3	Affordable prescription drugs	Access to safe, affordable housing	Supportive housing for individuals in need of wrap-around supportive services	Services or education to help reduce teen pregnancy	Counseling services for mental health issues such as depression, anxiety, and others for adults	Counseling services for mental health issues such as depression, anxiety, and others for adolescents/children
4	Affordable quality childcare	Livable wage job opportunities	Crisis or emergency care programs for mental health	Programs to help drug and other substance use disorder patients in recovery stay healthy	Affordable quality childcare	Affordable quality childcare

Rank	Carson City	Douglas County	Lyon County	Storey County	CTH Service Area	Total
5	Counseling services for mental health issues such as depression, anxiety, and others for adolescents/children	Affordable quality childcare	Counseling services for mental health issues such as depression, anxiety, and others for adolescents/children	Drug and other substance abuse treatment services	Livable wage job opportunities	Affordable prescription drugs
6	Crisis or emergency care programs for mental health	Affordable prescription drugs	Drug and other substance abuse education and prevention	General public transportation	Affordable prescription drugs	Crisis or emergency care programs for mental health
7	Livable wage job opportunities	Supportive housing for individuals in need of wrap-around supportive services	Counseling services for mental health issues such as depression, anxiety, and others for adults	Programs and initiatives to mitigate the health impacts of environmental changes	Crisis or emergency care programs for mental health	Livable wage job opportunities
8	Programs to help drug and other substance use disorder patients in recovery stay healthy	Crisis or emergency care programs for mental health	Affordable quality childcare	Transportation services for people needing to go to doctor's appointments or the hospital	Affordable healthcare services for individuals or families with low income	Affordable healthcare services for individuals or families with low income

Rank	Carson City	Douglas County	Lyon County	Storey County	CTH Service Area	Total
9	Access to quality education for youth	Coordination of patient care between the hospital and other clinics, private doctors, or other health service providers	Affordable prescription drugs	Services to help people learn about, and enroll in, programs that provide financial support for people needing healthcare	Supportive housing for individuals in need of wrap-around supportive services	Programs to help drug and other substance use disorder patients in recovery stay healthy
10	Affordable healthcare services for individuals or families with low income	Affordable healthcare services for individuals or families with low income	Livable wage job opportunities	Activities for youth (such as a public pool, roller skating rink, bowling alley)	Programs to help drug and other substance use disorder patients in recovery stay healthy	Supportive housing for individuals in need of wrap-around supportive services

## Telephone Survey Demographics

Respondents to the telephone survey (n=400) are split relatively equitably between Carson City (35.8%), Lyon County (31.5%), and Douglas County (29.3%), with a small fraction from Storey County (3.5%). Nearly one in two respondents (49.6%) are age 65 or older. Proportions of female and male respondents were relatively comparable (50.3% and 47.5%, respectively). As with the community survey, most respondents (91.3%) identify as White or Caucasian, with fewer than one in ten (8.1%) identifying as Hispanic, Latino, or other Spanish origin. Two in five (40.1%) reported total annual household income of \$75,000 or more, including one quarter of respondents with \$100,000 or above.

**Exhibit 55. Telephone Survey Respondent Demographics**

Demographic Variable	Percent of Telephone Survey Respondents
<b>COUNTY</b>	
Carson City	35.8% (n=143)
Lyon County	31.5% (n=126)
Douglas County	29.3% (n=117)
Storey County	3.5% (n=14)
<b>AGE<sup>^</sup></b>	
18-24	2.6%
25-34	5.6%
35-44	13.8%
45-54	12.8%
55-64	15.6%
65-74	26.3%
75 and older	23.3%
<b>GENDER IDENTITY</b>	
Female	51.0%
Male	48.2%
Gender non-binary	0.8%
Transgender female	-
Transgender male	-
<b>RACE<sup>+</sup></b>	
White or Caucasian	91.3%
Another race	3.0%
American Indian or Alaska Native	2.5%
Black or African American	1.0%

Demographic Variable	Percent of Telephone Survey Respondents
Asian	0.5%
Native Hawaiian or other Pacific Islander	0.0%
<b>ETHNICITY</b>	
Hispanic, Latino, or other Spanish origin	8.1%
Not Hispanic Latino, or other Spanish origin	91.9%
<b>ANNUAL HOUSEHOLD INCOME</b>	
Under \$15,000	5.8%
\$15,000-\$24,999	8.6%
\$25,000-\$34,999	8.6%
\$35,000-\$74,999	37.0%
\$75,000-\$99,999	15.3%
\$100,000 and above	24.8%

<sup>^</sup> Population age 18 and older only

<sup>+</sup> Survey instruction to 'check all that apply'

## Telephone Survey Findings

Telephone survey results produced frequency tables for survey questions measuring community engagement and community needs. The tables and analysis reported in this section feature these community needs-related questions.

### Community Engagement

Respondents most commonly reported belonging to none of the groups listed as options (37.0%). Among the options, the most popular group affiliation reported was with a church, temple, or religious group (31.5%).

**Exhibit 56: Do you belong to any of the following in the community?**

	Total
Church, temple, or religious group	31.5%
Volunteer group	18.3%
Recreational or sports club or team	16.0%
Social organization (such as Lions Clubs, Masonic organizations, etc.)	13.5%
Neighborhood association or club	12.8%
Professional or trade organizations	9.5%
School, university, technical training, or adult education	9.3%
Youth-focused organizations or groups (such as Cub Scouts, Girl Scouts, PTA, Gay Straight Alliance etc.)	8.0%
Other (Please specify)	7.5%
None of these	37.0%

- Other reported group affiliations include volunteer group (18.3%), recreational or sports club or team (16.0%), social organization (such as Lions Clubs, Masonic organizations, etc.) (13.5%), and/or neighborhood association or club (12.8%).



## Prioritized Needs

Similarly, to the community survey, respondents to the telephone survey prioritized access to safe, affordable housing, counseling services for mental health issues for adolescents/children, and affordable prescription drugs as issues that need more attention for improvement.

Telephone survey respondents also highly prioritized crisis or emergency care programs for mental health, and support services for children with developmental disabilities.

**Exhibit 57: Prioritized Community Needs (Based on percent saying, "Much more needed")**

Rank	Need
1	Access to safe, affordable housing
2	Counseling services for mental health issues such as depression, anxiety, and others for adolescents/children
3	Affordable prescription drugs
4	Crisis or emergency care programs for mental health
5	Support services for children with developmental disabilities
6	Counseling services for mental health issues such as depression, anxiety, and others for adults
7	Affordable quality childcare
8	Drug and other substance abuse education, prevention, and treatment services
9	Healthcare services for people experiencing homelessness
10	Long-term care or dementia care for seniors
11	General public transportation
12	Social services (other than healthcare) for people experiencing homelessness
13	Supportive housing for individuals in need of wrap-around supportive services
14	Women's health services / Prenatal care / Reproductive health services
15	Access to quality education for youth
16	Affordable healthcare services for individuals or families with low income
17	Healthcare services for seniors
18	Transportation services for people needing to go to doctor's appointments or the hospital
19	Programs to help steward and protect environmental resources
20	Programs and initiatives to mitigate the health impacts of environmental changes
21	Coordination of patient care between the hospital and other clinics, private doctors, or other health service providers
22	Programs to support community cohesion and inclusion, including those to combat discrimination and racism
23	Emergency care and trauma services
24	Programs for smoking cessation (including vaping)
25	Programs for obesity prevention, awareness, and care
26	Primary care services (such as a family doctor or other provider of routine care)
27	Accessible sources for affordable, nutritious food
28	Programs for diabetes prevention, awareness, and care
29	Programs for heart health or cardiovascular health
30	Access to clean, public places to play and exercise

# Demographic Comparison: Surveys vs. Secondary Data

Across a number of demographic variables, the telephone survey sample is comparable to Census Bureau American Community Survey (ACS) Five-Year Population Estimates for 2016-2020 for the aggregated communities of Carson City, Douglas County, Lyon County, and Storey County. An exception is the proportion of respondents identifying as Hispanic, Latino, or other Spanish origin (8.1% of the telephone sample vs. 18.1% of the estimated population).

The community survey sample is over-representative of people who live in Carson City and includes a larger proportion of respondents younger than age 55, more male respondents, and more respondents with annual household income less than \$75,000.

**Exhibit 58: Comparison of Survey Demographics to Secondary Data Demographics**

Demographic Variable	ACS 2016 2020 Population Estimates*	Community Survey	Telephone Survey
<b>COUNTY</b>			
Carson City	33.8%	47.8%	35.8%
Lyon County	34.1%	17.8%	31.5%
Douglas County	29.7%	27.4%	29.3%
Storey County	2.5%	7.0%	3.5%
<b>AGE^</b>			
18-24	8.3%	1.9%	2.6%
25-34	14.3%	30.3%	5.6%
35-44	13.9%	28.4%	13.8%
45-54	14.9%	22.5%	12.8%
55-64	19.7%	7.5%	15.6%
65-74	17.7%	7.2%	26.3%
75 and older	11.3%	2.2%	23.3%
<b>GENDER IDENTITY</b>			
Female	49.2%	34.1%	51.0%
Male	50.8%	64.1%	48.2%
Gender non-binary	-	0.5%	0.8%
Transgender female	-	0.8%	-
Transgender male	-	0.5%	-
<b>RACE+</b>			
White or Caucasian	88.0%	90.8%	91.3%
Another race	8.6%	1.4%	3.0%
American Indian or Alaska Native	3.7%	3.0%	2.5%
Black or African American	2.0%	2.1%	1.0%

Demographic Variable	ACS 2016 2020 Population Estimates*	Community Survey	Telephone Survey
Asian	3.1%	2.6%	0.5%
Native Hawaiian or other Pacific Islander	0.5%	0.7%	0.0%
<b>ETHNICITY</b>			
Hispanic, Latino, or other Spanish origin	18.1%	13.2%	8.1%
Not Hispanic Latino, or other Spanish origin	81.9%	86.8%	91.9%
<b>ANNUAL HOUSEHOLD INCOME</b>			
Under \$15,000	8.2%	1.1%	5.8%
\$15,000-\$24,999	7.9%	3.2%	8.6%
\$25,000-\$34,999	9.0%	21.8%	8.6%
\$35,000-\$74,999	34.3%	57.3%	37.0%
\$75,000-\$99,999	14.4%	5.8%	15.3%
\$100,000 and above	26.2%	10.8%	24.8%

\* Based on aggregate totals for Carson City, Douglas, Lyon, and Storey counties

^ Population age 18 and older only

+ Race alone or in combination with one or more other races; survey instruction to 'check all that apply'

## Secondary Population Research

The following analysis highlights diverse ethnicities, median incomes, and other lifestyle factors that impact the needs of the service area, as well as the development of effective strategies to meet evolving needs. Demographic analysis of the CTH Primary Service Area and the Quad-County Region provides a framework from which to better understand geographies, population trends, and the overall fabric of need across the community.

### Approach

The following data was gathered primarily from the United States Census Bureau 2016-2020 American Community Survey (ACS) Five-Year Estimates, the Nevada Rural and Frontier Health Data Book, 2021 (10<sup>th</sup> Edition), and the University of Nevada, Reno School of Medicine's Office of Statewide Initiatives' Nevada Instant Atlas. For full data sources, see appendix D.

The University of Nevada Reno School of Medicine's Office of Statewide Initiatives Nevada Instant Atlas. The atlas is compiled from over 50 sources, including information on demographic characteristics, social and economic characteristics, health insurance coverage, population health, healthcare workforce, and healthcare resources.<sup>27</sup>

The United States Census Bureau American Community Survey five-year estimates versus one-year estimates are intentionally utilized for this CHNA as the five-year estimates represent data collected over some time and provides a more accurate estimate of the measures, especially among high-risk populations or subgroups compared to one-year estimates. For example, one-year data for African Americans may have too small of a sample size to produce notable data points, however the five-year average will have enough observations to make an accurate, more reliable data point.<sup>28</sup>

**Please note**, for some measures, such as unemployment rates, the most contemporary data is preferable. Where appropriate, Crescendo Consulting Group has provided the most up-to-date figures.

The Carson Tahoe Health primary service area (CTH PSA) has been provided wherever possible to provide the most accurate in-depth outlook of the service area.

---

<sup>27</sup> The University of Nevada Reno School of Medicine's Office of Statewide Initiatives' Nevada Instant Atlas. Link: [med.unr.edu/statewide/nevada-instant-atlas](http://med.unr.edu/statewide/nevada-instant-atlas)

<sup>28</sup> American Community Survey, 2010 & 2019 Five-year Estimates. Link: [census.gov/programs-surveys/acs](http://census.gov/programs-surveys/acs)

## Social Vulnerability Index

The Social Vulnerability Index (SVI) helps identify areas of need in the community. Developed by the Centers for Disease Control and Prevention (CDC) as a metric for analyzing population data to identify vulnerable populations, the SVI's measures are housed within the domains of Socioeconomic Status, Household Composition and Disability, Minority Status and Language, Housing, and Transportation. This tool may be used to rank overall population well-being and mobility relative to county and state metrics. It can also be used to determine the most vulnerable populations during disaster preparedness and global pandemics.<sup>29</sup>

### Exhibit 59: Social Vulnerability Index Measures

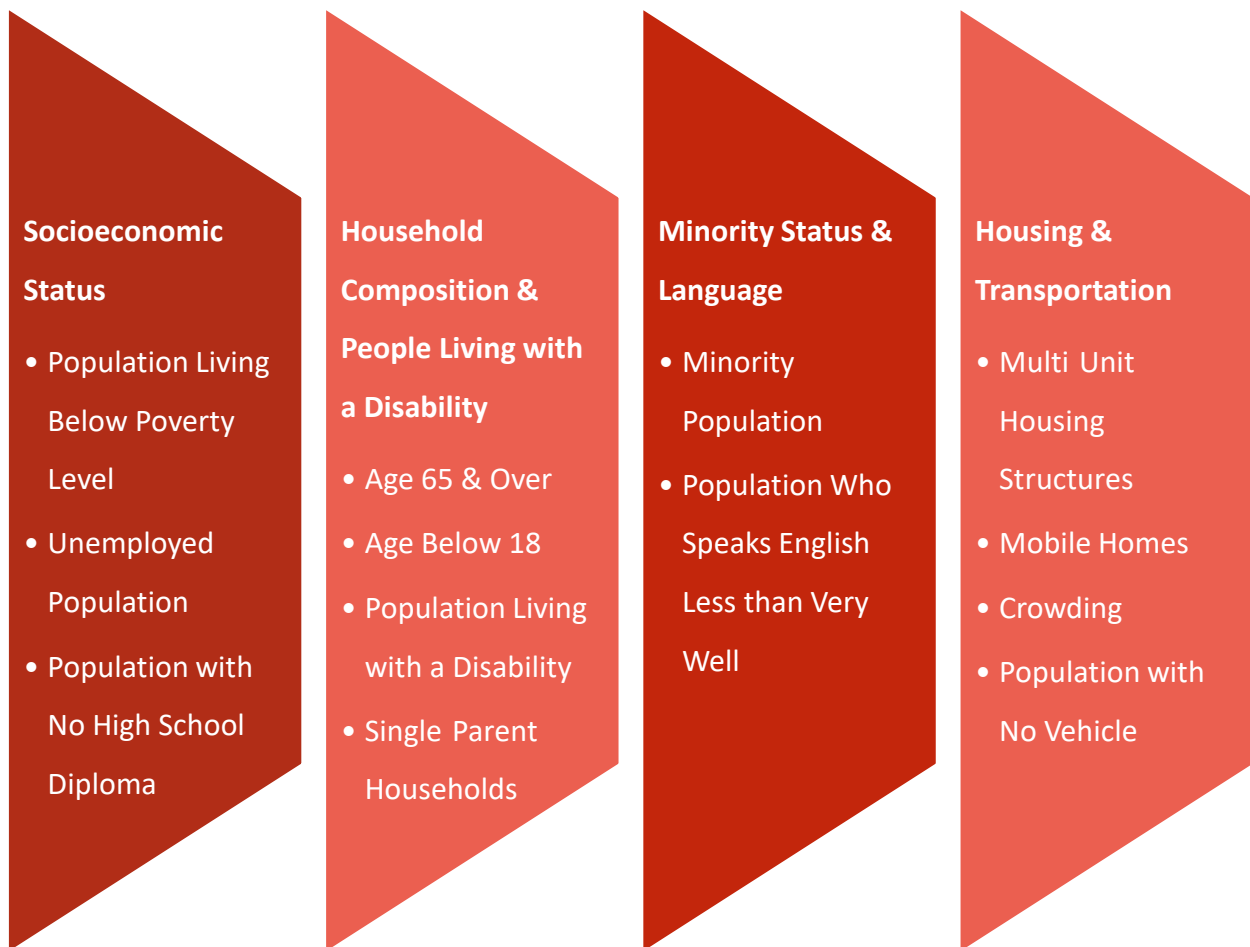

<sup>29</sup> Agency for Toxic Substances & Disease Registry. Link: [atsdr.cdc.gov/placeandhealth/svi/index.html](https://atsdr.cdc.gov/placeandhealth/svi/index.html)

The Social Vulnerability Index is especially helpful when comparing and contrasting the needs of vulnerable populations across geographies.

### Exhibit 60: Social Vulnerability Index

	United States	Nevada	CTH PSA	Carson City	Douglas County	Lyon County	Storey County
<b>Total Population</b>	326,569,308	3,030,281	126,246	55,244	48,486	55,667	4,086
Living in Poverty	12.8%	12.8%	8.5%	10.0%	7.5%	10.2%	9.2%
Unemployed <sup>30</sup>	3.6%	5.1%	ND	3.2%	3.4%	3.9%	3.6%
Median Household Income	\$64,994	\$62,043	\$64,887	\$58,305	\$71,415	\$58,814	\$64,000
Age 65 and Older	16.0%	15.8%	23.6%	20.3%	28.5%	21.2%	31.6%
Age Under 18	22.4%	22.7%	18.7%	20.4%	16.5%	21.2%	16.6%
Living with a Disability	12.7%	12.5%	16.2%	16.5%	14.4%	16.6%	21.3%
Single-Parent Households <sup>31</sup>	14.0%	28.0%	ND	24.0%	22.0%	21.0%	16.0%
Minority Population <sup>32</sup>	39.9%	51.8%	25.7%	33.9%	20.3%	25.9%	18.5%
Speaks English Less than Very Well <sup>33</sup>	8.2%	11.3%	4.9%	7.5%	3.5%	3.8%	0.5%
Multi-Unit Housing Structures	26.1%	30.0%	ND	25.6%	12.7%	6.5%	2.2%
Mobile Homes	6.0%	5.3%	11.6%	10.3%	5.6%	18.3%	21.4%
No Vehicle	8.5%	7.3%	3.3%	5.4%	2.0%	2.8%	1.1%

Source: U.S. Census Bureau, 2016-2020 American Community Survey Five-Year Estimates

**“ND” indicates that No Data was available for the data indicator.**

<sup>30</sup> U.S. Bureau Of Labor Statistics, Local Area Unemployment Statistics Information & Analysis. State & county data as of May 2022. Rates are not seasonally adjusted.

<sup>31</sup> County Health Rankings & Roadmaps, 2022. Link: [countyhealthrankings.org/app/nevada/2022/measure/factors/82/data](https://countyhealthrankings.org/app/nevada/2022/measure/factors/82/data)

<sup>32</sup> Population that does not identify as “White alone.”

<sup>33</sup> “Speak English less than “very well.”

## Social Determinants of Health

Social determinants of Health (SDoH) are the conditions in the environments where people are born, live, learn, work, play, worship, and grow older. These factors affect a wide range of health, functioning, and quality-of-life outcomes and risks. These conditions contribute to wide health disparities and inequities. For example, people who do not have access to grocery stores with healthy foods are less likely to have good nutrition. That raises their risk of health conditions like heart disease, diabetes, and obesity, and even lowers life expectancy relative to people who do have access to healthy foods.<sup>34</sup> Addressing social determinants of health is not only important for improving overall health, but also for reducing health disparities that are often rooted in social and economic disadvantages.

**Exhibit 61: SDoH Indicators**

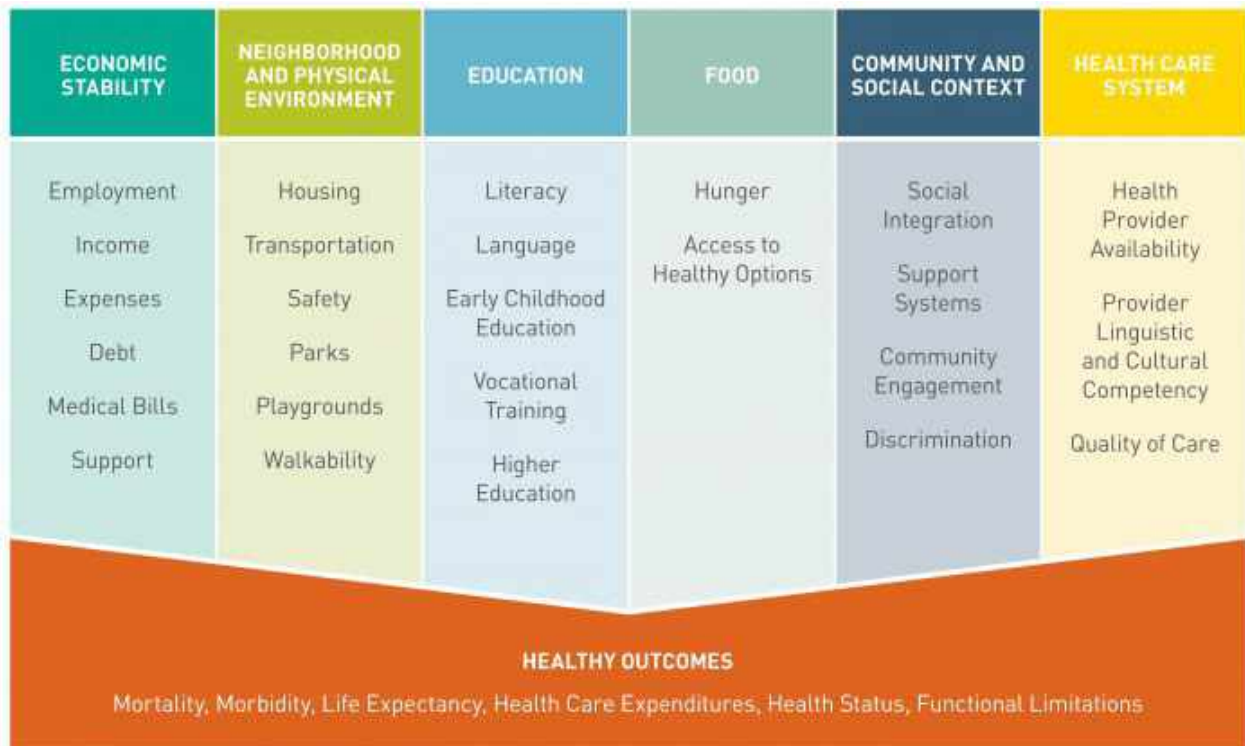

Source: Kaiser Family Foundation

<sup>34</sup> U.S. Department of Health and Human Services. *Healthy People 2030, Social Determinants of Health*. Link: [health.gov/healthypeople/objectives-and-data/social-determinants-health](https://health.gov/healthypeople/objectives-and-data/social-determinants-health)

## Economic Stability

Economic stability includes a wide range of factors not limited to employment, individual and family income, expenses, medical debt, and support.<sup>35</sup> People living in poverty are less likely to have access to healthcare, healthy food, stable housing, and opportunities for physical activity. These disparities mean people living in poverty are more likely to die from preventable diseases.<sup>36</sup> Research suggests that low-income status is associated with adverse health consequences, including shorter life expectancy, higher infant mortality rates, and other poor health outcomes.<sup>37</sup>

## Employment & Income

Income is an important contribution to a person’s socioeconomic status or the social standing or class of an individual or group often measured as a combination of education, income, and occupation.<sup>38</sup> Douglas County has the highest annual median household income within the Quad-County Region, higher than the CTH PSA as well.

Exhibit 62: Annual Median Household Income

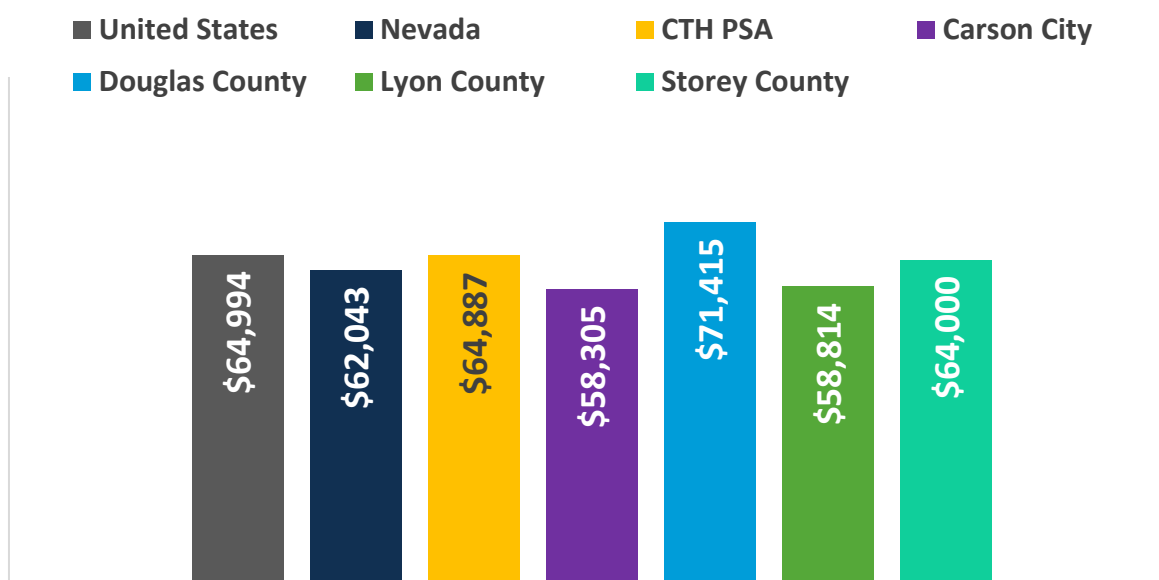

ANNUAL MEDIAN HOUSEHOLD INCOME

United States	Nevada	CTH PSA	Carson City	Douglas County	Lyon County	Storey County
\$64,994	\$62,043	\$64,887	\$58,305	\$71,415	\$58,814	\$64,000

Source: U.S. Census Bureau, 2016-2020 American Community Survey Five-Year Estimates

<sup>35</sup> Kaiser Family Foundation. *Beyond Healthcare: The Role of Social Determinants in Promoting Health & Health Equity*, 2018.

<sup>36</sup> U.S. Department of Health and Human Services, *Healthy People 2030. Social Determinants of Health, Economic Stability*.

<sup>37</sup> American Academy Of Family Physicians, *Poverty & Health. The Family Medicine Perspective*, April 2021.

<sup>38</sup> American Psychological Association, *Socioeconomic Status*.



## QUAD-COUNTY REGIONAL COMMUNITY HEALTH NEEDS ASSESSMENT

### Exhibit 63: Trend of Annual Per Capita Personal Income

	United States	Nevada	Carson City	Douglas County	Lyon County	Storey County
2020	\$59,510	\$53,720	\$56,510	\$78,416	\$44,098	\$65,971
2018	\$54,098	\$49,424	\$50,378	\$72,605	\$39,137	\$57,763
2016	\$49,812	\$45,323	\$45,264	\$66,023	\$35,955	\$45,379

Source: University of Nevada, Reno School of Medicine's Office of Statewide Initiatives, Nevada Instant Atlas. U.S. Department of Commerce Bureau of Economic Analysis

Temporary Assistance for Needy Families (TANF) is designed to provide assistance and care for dependent children in their own homes or in the homes of relative caregivers. TANF provides financial and support services such as childcare, transportation and other services.<sup>39</sup> TANF data for 2020 was unavailable due to the COVID-19 pandemic. The number of people using Nevada's TANF program has been consistently dropping over the past year, most likely as a result of federal assistance being provided through pandemic relief programs.

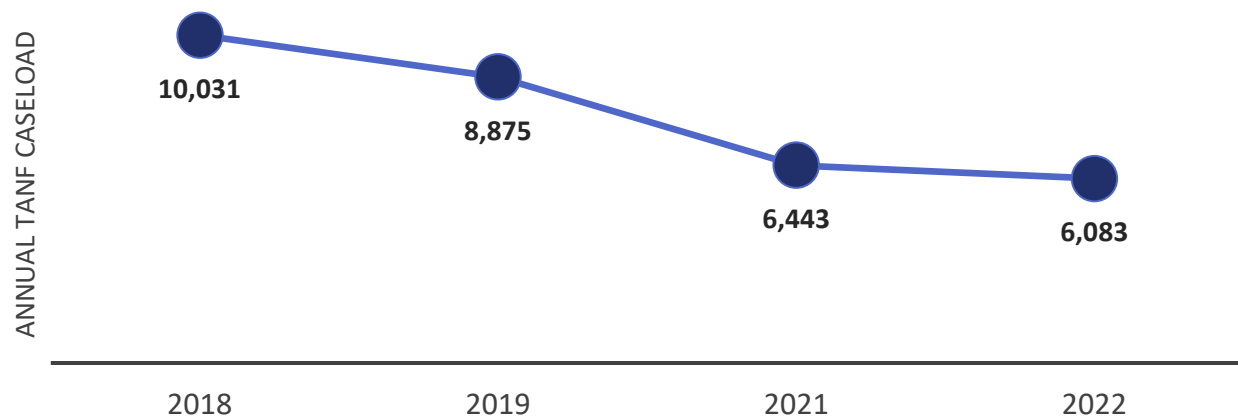

### Exhibit 64: Trend of Temporary Assistance for Needy Families Nevada Enrollment

	Caseload	Expenditures
2022	6,083	\$25,229,786
2021	6,443	\$26,917,354
2019	8,875	\$34,824,936
2018	10,031	\$39,116,848

Source: U.S. Census Bureau, 2016-2020 American Community Survey Five-Year Estimates

<sup>39</sup> Nevada Department of Health & Human Services Division of Welfare & Supportive Services, Temporary Assistance for Needy Families. Link: [dwss.nv.gov/TANF/Financial\\_Help/](https://dwss.nv.gov/TANF/Financial_Help/)

## QUAD-COUNTY REGIONAL COMMUNITY HEALTH NEEDS ASSESSMENT

Educational services, and healthcare and social assistance is the predominant industry in the CTH PSA (17.5%), Carson City (17.7%), and Douglas County (18.4%).

**Exhibit 65: Employment by Industry**

	United States	Nevada	CTH PSA	Carson City	Douglas County	Lyon County	Storey County
<b>Population Aged 16 +</b>	155,888,980	1,425,040	57,281	25,998	21,579	23,278	1,500
<b>Industry</b>							
Agriculture, forestry, fishing and hunting, and mining	1.7%	1.4%	1.5%	0.7%	1.7%	2.3%	0.6%
Construction	6.7%	7.2%	9.0%	9.1%	8.4%	8.2%	7.6%
Manufacturing	10.0%	4.8%	9.8%	9.4%	8.5%	12.7%	7.5%
Wholesale trade	2.5%	2.1%	1.8%	2.2%	0.9%	4.3%	3.1%
Retail trade	11.0%	11.5%	11.4%	11.8%	10.1%	13.9%	9.0%
Transportation and warehousing, and utilities	5.5%	6.2%	4.0%	3.4%	4.0%	7.9%	5.3%
Information	2.0%	1.5%	1.6%	1.7%	1.4%	0.9%	4.0%
Finance and insurance, and real estate and rental and leasing	6.6%	5.6%	4.4%	3.7%	6.4%	3.2%	8.0%
Professional, scientific, and management, and administrative and waste management services	11.7%	11.5%	8.7%	9.4%	9.0%	7.5%	14.1%

QUAD-COUNTY REGIONAL COMMUNITY HEALTH NEEDS ASSESSMENT

	United States	Nevada	CTH PSA	Carson City	Douglas County	Lyon County	Storey County
Educational services, and healthcare and social assistance	23.3%	16.3%	17.5%	17.7%	18.4%	14.5%	10.8%
Arts, entertainment, and recreation, and accommodation and food services	9.4%	23.1%	14.4%	14.4%	15.2%	11.6%	17.4%
Other services, except public administration	4.8%	4.6%	4.9%	4.5%	5.2%	5.1%	6.9%
Public administration	4.7%	4.2%	11.0%	12.2%	10.8%	7.8%	5.7%

Source: U.S. Census Bureau, 2016-2020 American Community Survey Five-Year Estimates

- A higher proportion of individuals in the professional, scientific, and management, and administrative and waste management services reside in Storey County than in other counties.
- Douglas County has the highest percentage of residents working in the arts, entertainment, and recreation, and accommodation and food services industry.

### Economically Disadvantaged Populations

Socioeconomic status can be determined by a family's income level, education level, and occupational status. Despite the differences in definition between poverty and socioeconomic status, researchers agree that there is a clear and established relationship between poverty, socioeconomic status, and health outcomes, including increased risk for disease and premature death.<sup>40</sup>

Data for the Carson Tahoe Health service area were based on aggregated data available at the ZIP Code level. For some measures, ZIP Code data was not available, so some CTH data points are omitted.

The Federal Poverty Level (FPL) is set by the U.S. government to help determine which individuals and families in the United States are living “in poverty”. For 2022, the Federal Poverty Guideline for a single person household is \$13,590, meaning that if you are an individual living alone and you make \$13,590 per year, you are living at the Federal Poverty Level. For a single parent with two children (3 person household), the level is \$23,030. For a family of 4, the Level is \$27,750. As the costs of living continue to grow, many Community Action Agencies determine need at 150-180% or more of the Federal Poverty Level.<sup>41</sup>

#### Exhibit 66: Population Living in Poverty

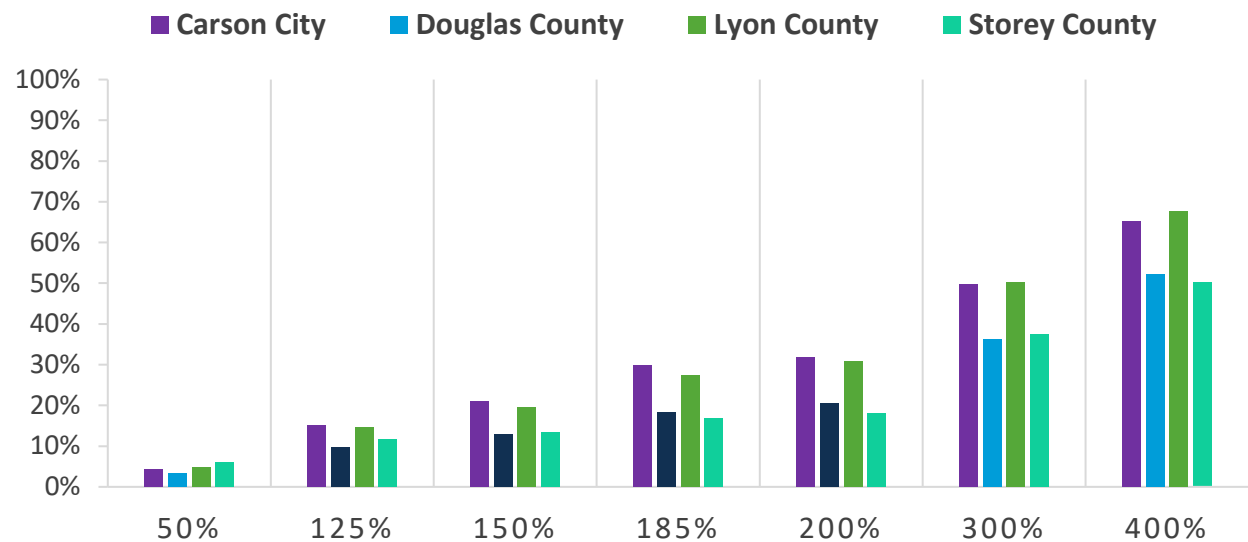

<sup>40</sup> U.S. Department of Health and Human Services, Healthy People 2030. Social Determinants of Health Literature Summaries, Poverty. Link: <https://health.gov/healthypeople/priority-areas/social-determinants-health/literature-summaries/poverty>

<sup>41</sup> <https://aspe.hhs.gov/topics/poverty-economic-mobility/poverty-guidelines>

## QUAD-COUNTY REGIONAL COMMUNITY HEALTH NEEDS ASSESSMENT

FEDERAL POVERTY LEVELS	Carson City	Douglas County	Lyon County	Storey County
50%	4.3%	3.2%	4.7%	6.1%
125%	15.1%	9.7%	14.6%	11.6%
150%	21.1%	13.0%	19.6%	13.4%
185%	29.9%	18.4%	27.3%	16.7%
200%	31.9%	20.5%	30.9%	18.1%
300%	49.7%	36.3%	50.1%	37.4%
400%	65.2%	52.1%	67.6%	50.3%

Source: U.S. Census Bureau, 2016-2020 American Community Survey Five-Year Estimates

**Exhibit 67: Trend of Children Living in Poverty as Measured at 100% of Federal Poverty Line**

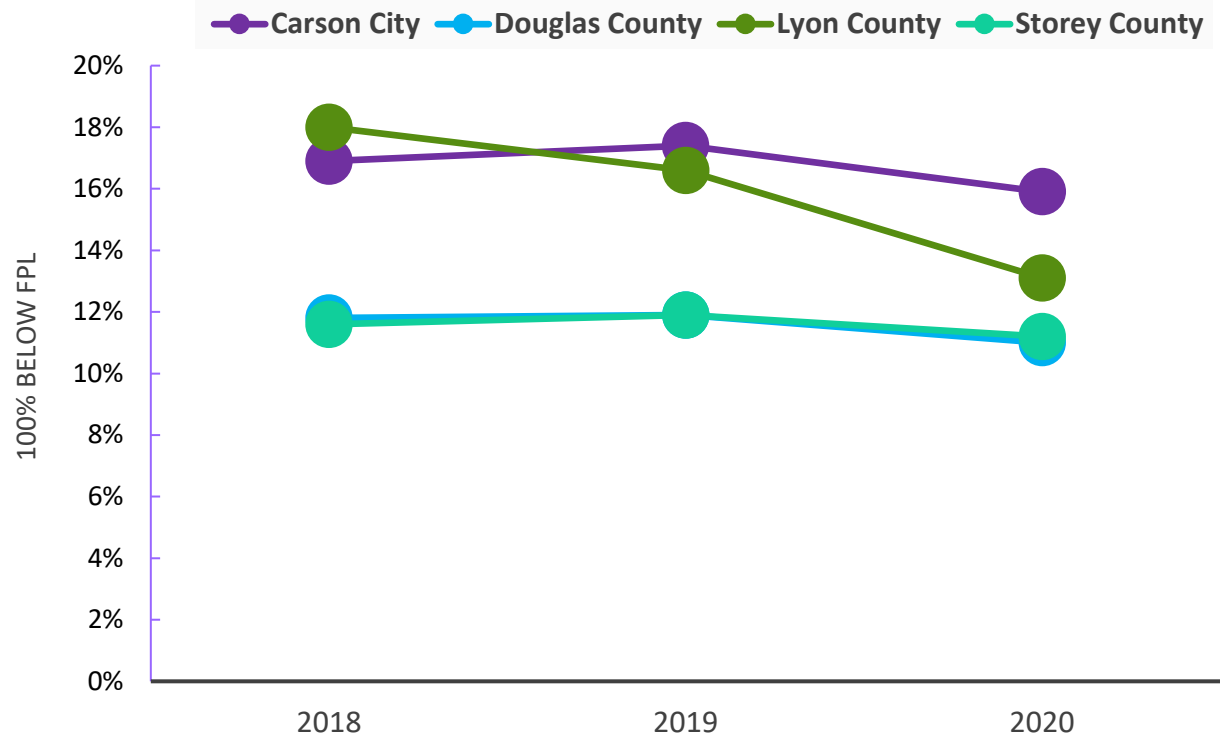

	United States	Nevada	Carson City	Douglas County	Lyon County	Storey County
2020	15.7%	16.7%	15.9%	11.0%	13.1%	11.2%
2019	16.8%	17.6%	17.4%	11.9%	16.6%	11.9%
2018	18.0%	18.4%	16.9%	11.8%	18.0%	11.6%

Source: U.S. Census Bureau, Small Area Income & Poverty Estimates

- The percentage of children under age 18 living in poverty in Carson City in 2020 is slightly higher than the national percentage (15.9%, 15.7%, respectively).

## Neighborhood & Physical Environment

The neighborhoods people live in have a major impact on their health and well-being. Many people in the United States live in neighborhoods with high rates of violence, unsafe air or water, and other health and safety risks. The physical environment includes housing and transportation, parks and playgrounds, and the opportunities for recreational opportunities.<sup>42</sup>

### Housing Stock & Cost

Housing is an important social determinant of health, as poor-quality housing is associated with negative health outcomes, including chronic disease, injury, and poor mental health.<sup>43</sup>

Of the 56,186 housing units within the PSA, only 6.8% are vacant, a lower percentage compared to Nevada. Douglas County has the highest percentage of vacant housing units, followed closely by Storey County, which is likely due to seasonal or vacation homes. The rental vacancy rate is highest in Douglas and Lyon Counties (5.4% and 5.3%, respectively).

*“Many forces have combined to create a rental market that’s setting records for a lack of vacancies & high costs, including a historic shortage of housing.”*

*National Association of Realtors, 2022*

### Exhibit 68: Housing Units

	United States	Nevada	CTH PSA	Carson City	Douglas County	Lyon County	Storey County
<b>Total Housing Units</b>	138,432,751	1,268,533	56,186	24,132	24,570	23,697	1,969
Occupied housing	88.4%	89.1%	93.2%	94.7%	85.8%	91.7%	86.5%
Vacant housing	11.6%	10.9%	6.8%	5.3%	14.2%	8.3%	13.5%

Source: U.S. Census Bureau, 2016-2020 American Community Survey Five-Year Estimates

### Exhibit 69: Vacancy Rate

	United States	Nevada	Carson City	Douglas County	Lyon County	Storey County
Homeowners	1.4%	1.7%	0.8%	1.6%	1.3%	0.0%
Rentals	5.8%	7.2%	2.1%	5.4%	5.3%	0.0%

Source: U.S. Census Bureau, 2016-2020 American Community Survey Five-Year Estimates

<sup>42</sup> Kaiser Family Foundation. *Beyond Healthcare: The Role of Social Determinants in Promoting Health & Health Equity*, 2018. Link: [kff.org/racial-equity-and-health-policy/issue-brief/beyond-health-care-the-role-of-social-determinants-in-promoting-health-and-health-equity/](https://www.kff.org/racial-equity-and-health-policy/issue-brief/beyond-health-care-the-role-of-social-determinants-in-promoting-health-and-health-equity/)

<sup>43</sup> Centers for Disease Control & Prevention, *Social Determinants Of Health*. Link: [cdc.gov/socialdeterminants/index.htm](https://www.cdc.gov/socialdeterminants/index.htm)

## QUAD-COUNTY REGIONAL COMMUNITY HEALTH NEEDS ASSESSMENT

Median homeowner costs in the CTH PSA are slightly higher than statewide medians at \$1,577, while rent is slightly lower. The median cost of a mortgage and rental unit in Douglas County is higher than both state and national medians.

**Exhibit 70: Median Cost of Housing**

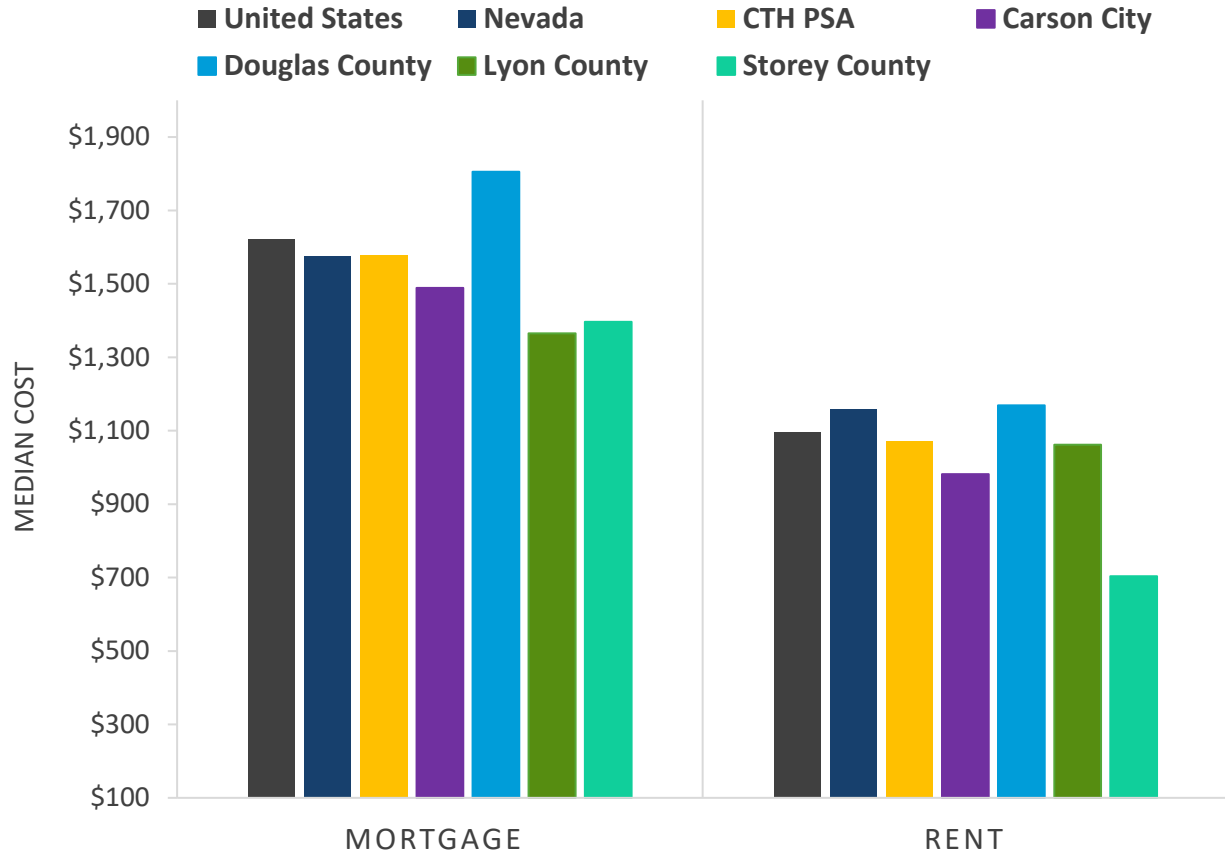

	United States	Nevada	CTH PSA	Carson City	Douglas County	Lyon County	Storey County
Median Mortgage	\$1,621	\$1,574	\$1,577	\$1,489	\$1,805	\$1,365	\$1,397
Median Rent	\$1,096	\$1,159	\$1,070	\$982	\$1,169	\$1,062	\$704

Source: U.S. Census Bureau, 2016-2020 American Community Survey Five-Year Estimates

## QUAD-COUNTY REGIONAL COMMUNITY HEALTH NEEDS ASSESSMENT

Close to one in three households with a mortgage and renters in all geographies are cost burdened. Roughly one in ten homes without a mortgage in the Quad-County Region are cost burdened.

*“Cost-burdened households are households who pay more than 30.0% of their income for housing and may have difficulty affording necessities such as food, clothing, transportation, and medical care.”*

*The U.S. Department of Housing & Urban Development*

**Exhibit 71: Cost-burdened Households**

	United States	Nevada	CTH PSA	Carson City	Douglas County	Lyon County	Storey County
With a Mortgage	20.6%	23.0%	32.9%	30.9%	34.6%	29.2%	27.7%
Without a Mortgage	10.4%	8.7%	11.5%	10.2%	12.7%	11.2%	11.5%
Renter (35.0% or more)	40.0%	40.8%	33.1%	29.6%	36.9%	36.2%	32.9%

Source: U.S. Census Bureau, 2016-2020 American Community Survey Five-Year Estimates

**Exhibit 72: Median Home Value**

United States	Nevada	CTH PSA	Carson City	Douglas County	Lyon County	Storey County
\$229,800	\$290,200	\$318,698	\$299,900	\$416,900	\$238,600	\$264,000

Source: U.S. Census Bureau, 2016-2020 American Community Survey Five-Year Estimates

The stock of low-rent units, under \$600 per month, in Nevada has been on the decline since 2011, declining from 59.7% to 48.4%.

**Exhibit 73: Trend of Low-Rent Units**

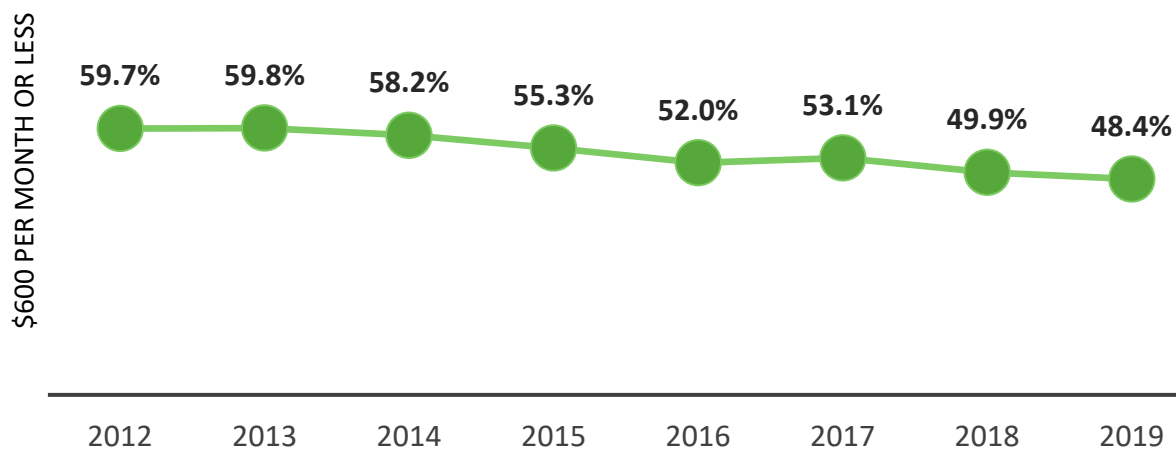

Source: Harvard Joint Center for Housing Studies, America's Rental Housing 2022 Report



## QUAD-COUNTY REGIONAL COMMUNITY HEALTH NEEDS ASSESSMENT

Nationally, rents for available apartments rose 15.0% since 2021, while the median listed rent for an available apartment rose above \$2,000 a month for the first time. According to the Nevada Housing Coalition,

*“Fair Market Rent for a two-bedroom apartment is \$1,135. In order to afford this level of rent and utilities, without paying more than 30.0% of income on housing, a household must earn \$3,785 monthly or \$45,416 annually. Assuming a 40-hour work week, 52 weeks per year.”*

### Exhibit: State Wage & Housing Facts<sup>44</sup>

<b>Nevada Minimum Wage</b>	<b>\$10.50</b>
<b>Average Renter Hourly Wage</b>	\$20.66
<b>Two-Bedroom Housing Wage</b>	\$23.70
<b>Number of Renter Households</b>	485,147
<b>Percent Renters</b>	43.0%

Although the minimum wage in Nevada is set to increase by \$0.75 cents until it reaches \$11.00 per hour over the next two years, the cost of housing in 2022 is expected to outweigh the benefits of wage increases.<sup>45</sup>

Source: National Low Income Housing Coalition. Nevada Factsheet 2022 Out of Reach

Fair market housing wage indicates the wage individuals would need to make hourly in 2021 to afford a two-bedroom rental unit.

Although it can be expected that the fair market housing wage has increased since 2021, at the time of data collection Storey County residents would have needed to earn hourly wage of \$23.40 to afford a two-bedroom rental unit according to fiscal year 2021 fair market rent, the highest within the service area.

### Exhibit 74: Fair Market Housing Wage

Nevada	Carson City	Douglas County	Lyon County	Storey County
\$21.83	\$19.67	\$19.48	\$15.54	\$23.40

Source: National Low Income Housing Coalition. Nevada Factsheet 2021 Out of Reach

### Exhibit 75: Housing Costs

FISCAL YEAR 2021 FAIR MARKET RENT	Nevada	Carson City	Douglas County	Lyon County	Storey County
Annual income needed to afford a two-bedroom rental unit	\$45,416	\$40,920	\$40,520	\$32,320	\$48,680
Full-time jobs at minimum wage to afford a two-bedroom rental unit	2.2	2.0	2.0	1.6	2.4

Source: National Low Income Housing Coalition. Nevada Factsheet 2021 Out of Reach

<sup>44</sup> National Low Income Housing Coalition. Nevada Factsheet 2021 Out of Reach. Link: <https://reports.nlihc.org/sites/default/files/oor/files/reports/state/nv-2021-oor.pdf>

<sup>45</sup> State of Nevada Department of Business & Industry. Nevada’s minimum wage & daily overtime rates to increase July 1, 2022. Link: [Business.nv.gov/News\\_Media/Press\\_Releases/2022/Labor/Nevada%E2%80%99s\\_minimum\\_wage\\_and\\_daily\\_overtime\\_rates\\_to\\_increase\\_July\\_1\\_2022/](https://business.nv.gov/News_Media/Press_Releases/2022/Labor/Nevada%E2%80%99s_minimum_wage_and_daily_overtime_rates_to_increase_July_1_2022/)

## QUAD-COUNTY REGIONAL COMMUNITY HEALTH NEEDS ASSESSMENT

Fair market rent increased in all four counties between 2021 and 2022. The largest increase is in rent prices for a four-bedroom in Lyon and Storey Counties, which increased by \$302 and \$279, respectively. Rent for a one-bedroom increased in all four counties by an average of \$132 in 2022 while rent for a two-bedroom increased in all four counties by an average of nearly \$156. The lowest increase was for an efficiency in Carson City, which went up by \$61 in 2022.

### Exhibit 76: Fair Market Rent

	Carson City		Douglas County		Lyon County		Storey County	
	2021	2022	2021	2022	2021	2022	2021	2022
Efficiency	\$675	\$736	\$772	\$853	\$630	\$776	\$803	\$926
One-Bedroom	\$788	\$853	\$830	\$986	\$634	\$798	\$964	\$1,108
Two-Bedroom	\$1,023	\$1,108	\$1,013	\$1,188	\$808	\$994	\$1,217	\$1,394
Three-Bedroom	\$1,464	\$1,574	\$1,435	\$1,688	\$1,156	\$1,412	\$1,742	\$1,980
Four-Bedroom	\$1,771	\$1,896	\$1,686	\$1,792	\$1,399	\$1,701	\$2,107	\$2,386

Source: United States Department of Housing and Urban Development, Program Parameters & Research Division

### Exhibit 77: Most Expensive Areas in Nevada

Metropolitan Statistical Area	Housing Wage
Reno MSA	\$23.40
Vegas-Henderson-Paradise MSA	\$21.98
Carson City MSA	\$19.67
Douglas County	\$19.48

The most expensive areas in Nevada, ranked from highest to lowest in terms of two-bedroom housing wage, include multiple areas in the Quad-County Region.

Source: National Low Income Housing Coalition. Nevada Factsheet 2021 Out of Reach

There is a shortage of rental homes affordable and available to extremely low-income households in Nevada, whose incomes are at or below the poverty guideline or 30.0% of their area median income. Many of these households are severely cost burdened. Low-income households are more likely than other renters to sacrifice other necessities like healthy food and healthcare to pay the rent, and to experience unstable housing situations like evictions.<sup>46</sup>

<sup>46</sup> National Low-income Coalition. Link: [nlihc.org/](http://nlihc.org/)

In 2021, Carson City had the highest number of subsidized housing units among the counties.

**Exhibit 78: Number of Households Living In Subsidized Housing**

Nevada	Carson City	Douglas County	Lyon County	Storey County
22,231	770	236	164	ND

Source: U.S. Department of Housing & Urban Development’s A Picture of Subsidized Households Housing Insecurity, 2021

**Housing Instability**

Housing instability encompasses several challenges, such as having trouble paying rent, overcrowding, moving frequently, staying with relatives, or spending the bulk of household income on housing. These experiences may negatively affect physical health and make it harder to access healthcare.<sup>47</sup>

The Point-in-Time (PIT) count is a HUD mandated count of sheltered and unsheltered people experiencing homelessness. The count is conducted on a specific night (i.e., a single “point in time”) during the last two weeks in January to minimize duplicated counts and give a more accurate picture of homelessness in Nevada’s 15 rural counties.

The 2021 count was substantially impacted by COVID-19, as the ability to conduct a comprehensive Unsheltered Count was affected and limited the Continuum of Care’s ability to better understand the root causes of homelessness through surveys and interviews.

Winter weather conditions during count activities may have reduced the number of individuals visible to be counted during the observation-only head count that was conducted. Count teams did not attempt to ascertain the occupancy of tents, RVs, vehicles, and outbuildings, which may have led to an underestimation of the true number of individuals experiencing unsheltered homelessness in 2021.<sup>48</sup>

**Point-in-Time Count**

The PIT is conducted to,

- Measure and monitor trends and changes in homelessness on local and national levels and track progress toward ending homelessness.
- Help communities understand what resources are needed and strategize the best ways to use them to end homelessness.

*Rural Nevada Continuum of Care*

<sup>47</sup> U.S. Department of Health and Human Services, *Healthy People 2030. Social Determinants of Health Literature Summaries, Housing Instability.* Link: [health.gov/healthypeople/priority-areas/social-determinants-health/literature-summaries/housing-instability#cit2](https://health.gov/healthypeople/priority-areas/social-determinants-health/literature-summaries/housing-instability#cit2)

<sup>48</sup> Rural Nevada Continuum of Care 2021 Point-in-Time Count. Link: [legistarweb-production.s3.amazonaws.com/uploads/attachment/pdf/1025858/-Rural\\_Nevada\\_Continuum\\_of\\_Care\\_Point-in-Time\\_Count\\_Report.pdf](https://legistarweb-production.s3.amazonaws.com/uploads/attachment/pdf/1025858/-Rural_Nevada_Continuum_of_Care_Point-in-Time_Count_Report.pdf)

## QUAD-COUNTY REGIONAL COMMUNITY HEALTH NEEDS ASSESSMENT

In total, **860** people were identified as housing insecure within the Quad-County Region.

Carson City had the highest number of housing insecure individuals at 480, while Lyon County had 296 housing insecure residents. Three of the four counties have children experiencing housing insecurity or instability.

Carson City and Lyon County have housing insecure individuals residing in motels (79 and 21, respectively). There are 82 unsheltered residents in Carson City and 20 unsheltered residents of Lyon County.

### About the Data

A value of **zero** indicates that the count component was conducted within that county, but no individuals were counted. A value of **ND** indicates No Data available.

### Exhibit 79: Point-in-Time Count

2021	Nevada	Carson City	Douglas County	Lyon County	Storey County
Sheltered	76	52	0	1	ND
Unsheltered	223	82	3	20	0
Motel Count	285	79	0	21	0
School Count	1,161	267	81	254	0
<b>Total</b>	<b>1,745</b>	<b>480</b>	<b>84</b>	<b>296</b>	<b>0</b>

Source: Rural Nevada Continuum of Care 2021 Point-in-Time Count

- Carson City reported the highest number of individuals living in motels. However, Douglas and Storey counties conducted the motel count but found no individuals living in motels.
- The categories for the school count include residents who are “doubled-up,” wherein families share the housing of other persons and likely do not have legal rights or a lease to ensure their continued housing; children living in a hotel or motel; children in a shelter (which also includes transitional housing and, in some cases, waiting for foster care); and children who are unsheltered.
- The School Count for Carson City and Lyon County had the most children who were experiencing housing insecurity or instability, with 267 and 254, respectively.

## Exercise & Physical Activity

Access to exercise opportunities measures the percentage of individuals who live reasonably close to a location for physical activity such as parks or recreational facilities. Individuals are considered to have access to exercise opportunities if they reside in a census block that is within a half mile of a park or reside in an urban census block that is within one mile of a recreational facility or reside in a rural census block that is within three miles of a recreational facility.<sup>49</sup>

Poor health outcomes related to inadequate physical activity can lead to heart disease, type two diabetes, and cancer even for those with no preexisting risk factors. Obesity, high blood pressure, and high blood cholesterol can also result from poor physical activity.

### Exhibit 80: Access to Exercise Opportunities

United States	Nevada	Carson City	Douglas County	Lyon County	Storey County
86.0%	90.0%	93.0%	76.0%	54.0%	17.0%

Source: County Health Rankings & Roadmaps, 2021

Self-reported physical activity indicates the proportion of those 18 and older who did not meet aerobic physical activity recommendations of at least 150 minutes per week of moderate-intensity, or 75 minutes per week of vigorous intensity, or an equivalent combination.<sup>50</sup>

### Exhibit 81: Self-Reported Physical Activity in Adults

	United States	Nevada	Carson City	Douglas County	Lyon County	Storey County
No Leisure-Time Physical Activity	23.0%	25.6%	26.1%	22.5%	26.7%	21.6%

Source: National Center for Chronic Disease Prevention and Health Promotion, Division of Population Health. Behavioral Risk Factor Surveillance System, 2019

- Over a quarter of the population in Carson and Lyon County reported having no leisure time physical activity, higher than the national figure.

<sup>49</sup> County Health Rankings & Roadmaps, Access to Exercise Opportunities.

Link: [countyhealthrankings.org/app/nevada/2022/measure/factors/132/map](https://countyhealthrankings.org/app/nevada/2022/measure/factors/132/map)

<sup>50</sup> County Health Rankings & Roadmaps, Physical Inactivity. Link: [countyhealthrankings.org/app/nevada/2022/measure/factors/70/map](https://countyhealthrankings.org/app/nevada/2022/measure/factors/70/map)

## QUAD-COUNTY REGIONAL COMMUNITY HEALTH NEEDS ASSESSMENT

Carson City has the highest percentage of obese adults within the Quad-County Region, about one in seven members of the adult population.

**Exhibit 82: Overweight or Obese Adults**

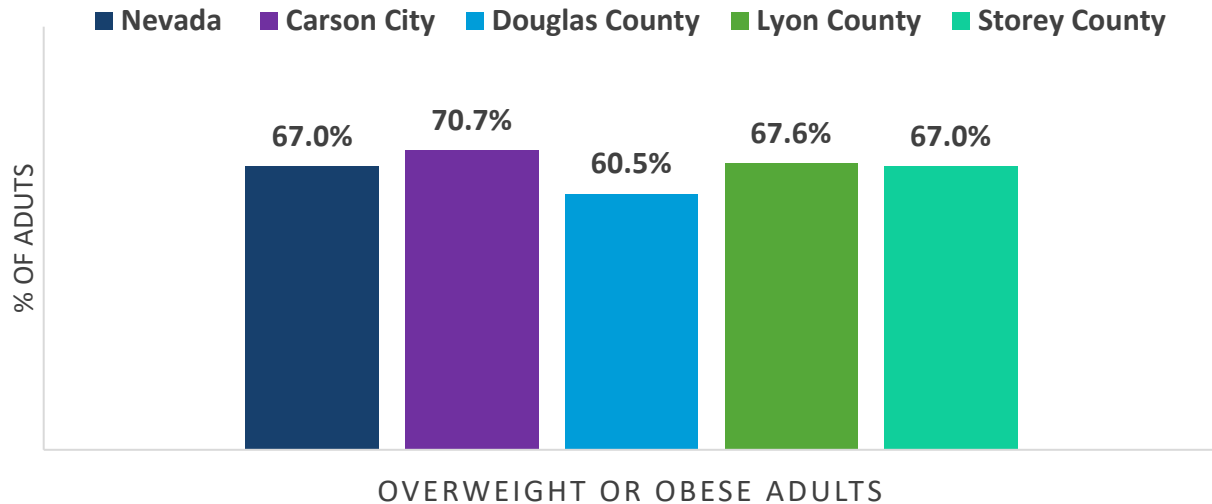

	Nevada	Carson City	Douglas County	Lyon County	Storey County
Overweight or Obese	67.0%	70.7%	60.5%	67.6%	67.0%

Source: Nevada Department of Health & Human Services Office of Analytics. 2021 Nevada Health Profiles

Physical activity indicators self-reported by high school and middle school students refers to the percentage of high school students who were physically active at least 60 minutes per day on five or more days during the seven days before the 2019 Youth Behavioral Risk Factor Surveillance Survey. Physical activity is higher among middle school students than among high school students, except for Lyon and Storey County students.

**Exhibit 83: Self-Reported Physical Activity by Youth<sup>51</sup>**

PHYSICALLY ACTIVE STUDENTS	Nevada	Carson City	Douglas County	Lyon & Storey County
High school students	38.4%	39.2%	49.7%	52.0%
Middle school students	42.5%	47.2%	52.7%	49.1%

Source: State of Nevada, Division of Public and Behavioral Health and the University of Nevada, Reno. 2019 Nevada High School & Middle School Youth Risk Behavior Survey Report

<sup>51</sup> Percentage of high school students who were physically active at least 60 minutes/day on 5 or more days during the 7 days before the survey.

## QUAD-COUNTY REGIONAL COMMUNITY HEALTH NEEDS ASSESSMENT

The green highlighted areas below indicate locations of parklands within the service area. Carson and Douglas County are in close proximity to the Lake Tahoe area, allowing ample accessibility to outdoor recreational activities. Lyon County is home to Humboldt-Toiyabe National Forest, consisting of 6.3 million acres making it the largest National Forest in the lower 48 states.<sup>52</sup>

**Exhibit 84: Quad-County Region Park Locations**

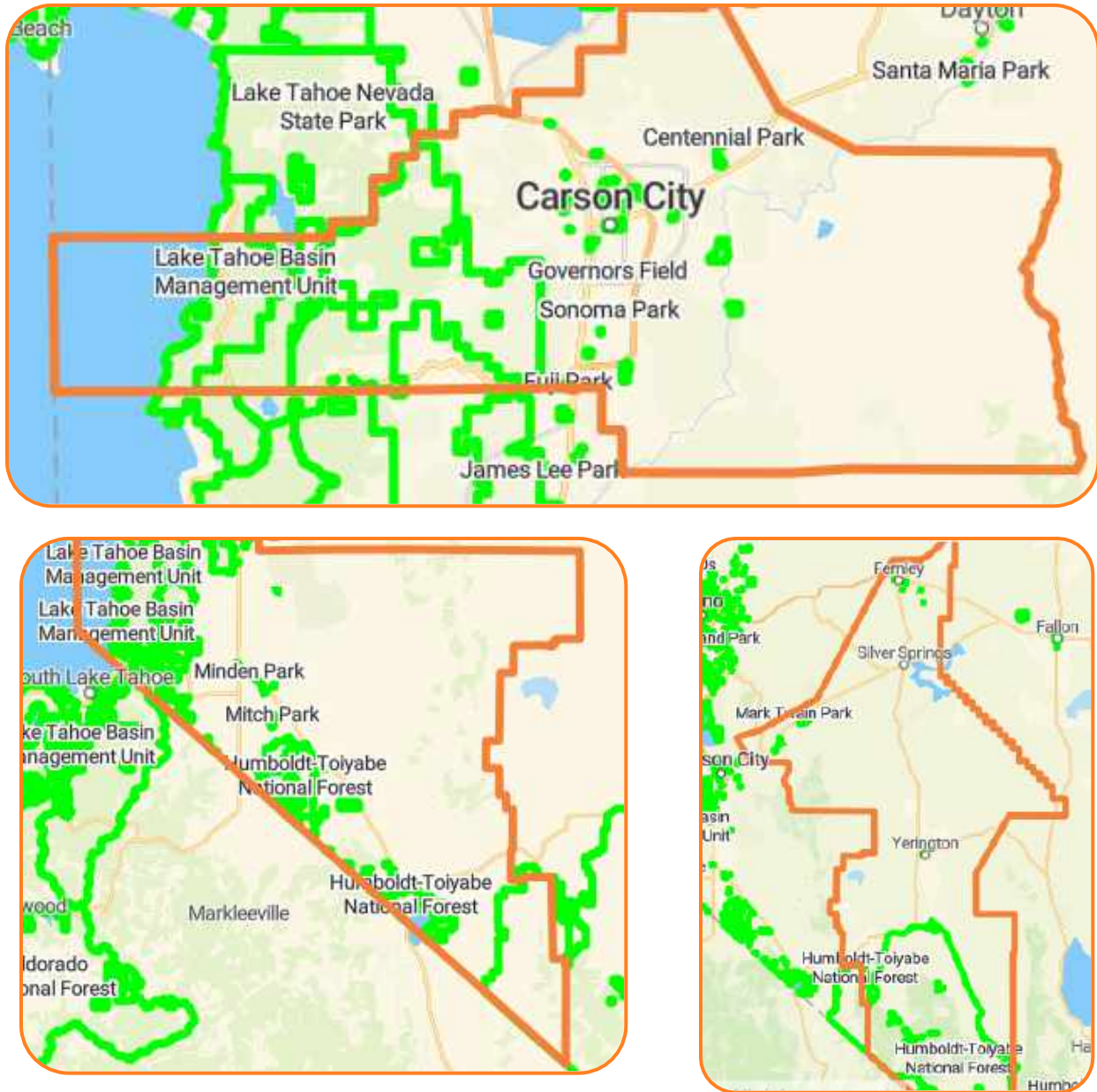

Source: PolicyMap (Park Locations). Trust for Public Land: ParkServe, 2020

<sup>52</sup> U.S. Department of Agriculture, Forest Service.



## QUAD-COUNTY REGIONAL COMMUNITY HEALTH NEEDS ASSESSMENT

Carson City alone has over 100 miles of walking and biking trails and over 40 verified walking and biking trails and over 100 miles of available to the public, providing sufficient opportunities for community residents (and visitors) to bike, hike, walk, backpack and more.<sup>53</sup>

**Exhibit 85: Estimated Number of Available Trails in Carson City**

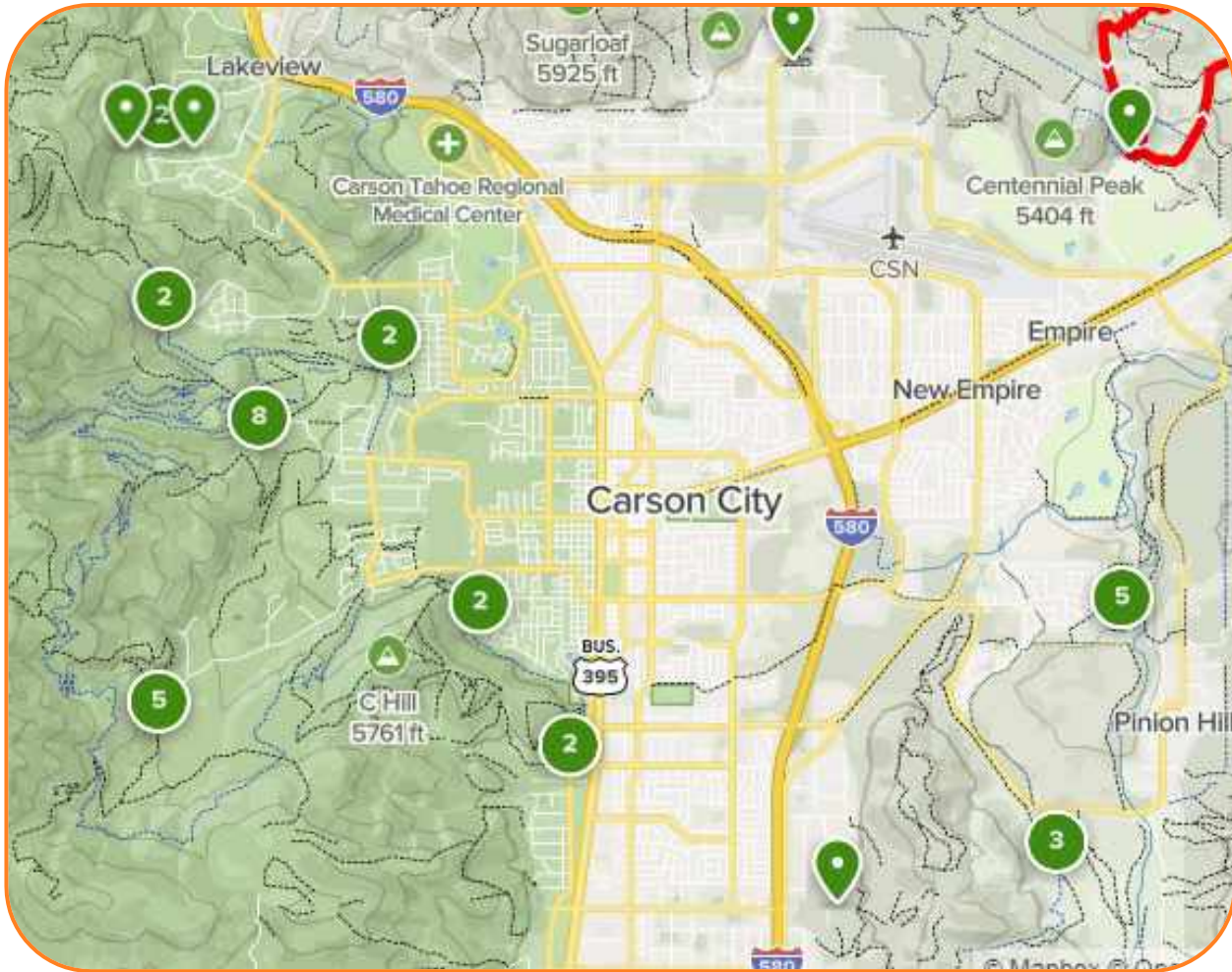

Source: AllTrails. Carson City, 2022

<sup>53</sup> All Trails. Link: [alltrails.com/us/nevada/carson-city/walking](https://www.alltrails.com/us/nevada/carson-city/walking)



## QUAD-COUNTY REGIONAL COMMUNITY HEALTH NEEDS ASSESSMENT

Douglas and Lyon County are home to several mountain peaks, offering opportunities for regular physical activity.

**Exhibit 86: Estimated Number of Available Trails Within the Service Area**

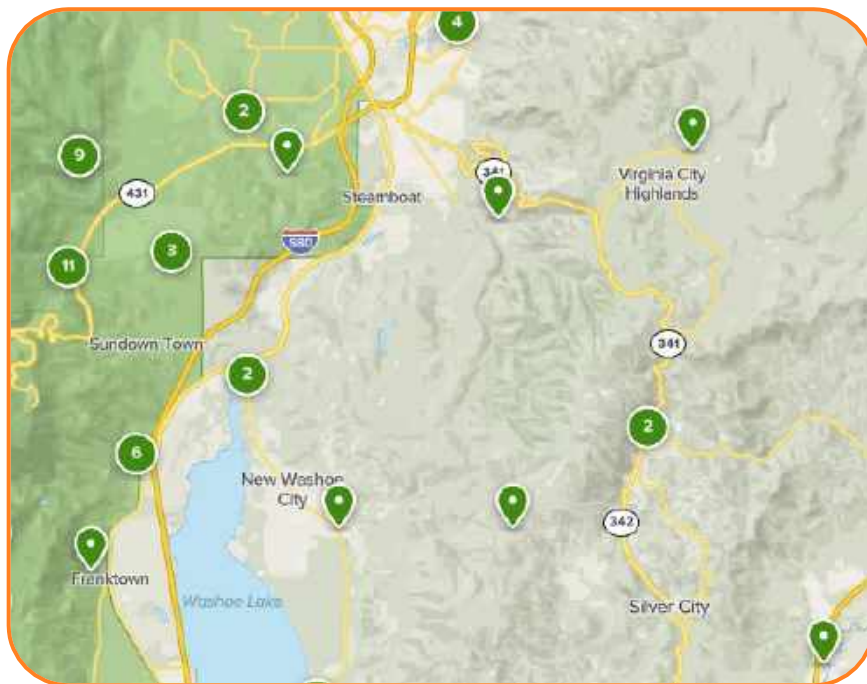
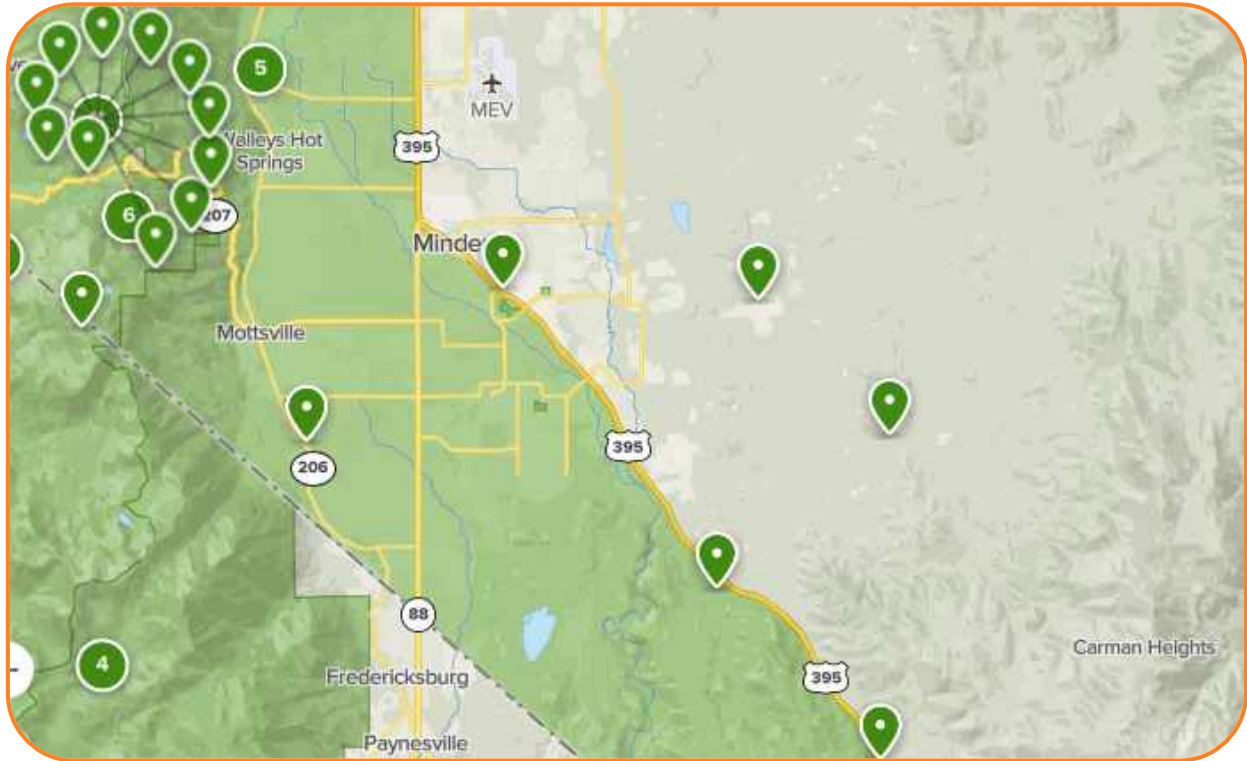

Source: AllTrails, 2022

**Exhibit 87: Virginia City, Near the Summit of Mount Davidson**

Because of its rural geography, Storey County can present as having limited access to opportunities to physical activities. However, Storey County is home to Mount Davidson, the highest point within Virginia Mountain Range. This, and other mountains, provide miles of often off-the-map trails for both hiking and mountain biking for its residents.<sup>54</sup>



Source: SummitPost, Mt. Davidson

In the table below, over half of all middle and high school students reported spending at least three hours on the computer or watching television per school day. This data was collected prior to the COVID-19 pandemic. Because of remote learning and other virtual events, these figures are expected to increase from 2019 levels.

**Exhibit 88: Self-Reported Physical Health by Students**

	Nevada	Carson City	Douglas County	Lyon & Storey County
<b>High School</b>				
Overweight high school students <sup>55</sup>	15.6%	19.3%	16.1%	15.2%
Obese students	12.7%	9.2%	5.1%	14.0%
Students who used the computer 3+ hours per school day or watched TV 3+ hours	59.6%	58.9%	57.0%	51.2%
<b>Middle School</b>				
Students who used the computer 3+ hours per school day or watched TV 3+ hours	59.6%	56.6%	49.8%	56.0%

Source: State of Nevada, Division of Public and Behavioral Health and the University of Nevada, Reno. 2019 Nevada High School & Middle School Youth Risk Behavior Survey Report

- Approximately one-fifth of Carson high school students are overweight, and 14.0% of Storey County high school students are obese.

<sup>54</sup> SummitPost, Mt. Davidson. Link: [summitpost.org/mount-davidson-nv/153745](http://summitpost.org/mount-davidson-nv/153745)

<sup>55</sup> Students who were ≥85th percentile but <95th percentile for body mass index, based on sex- and age-specific reference data from the 2000 CDC growth chart.

## QUAD-COUNTY REGIONAL COMMUNITY HEALTH NEEDS ASSESSMENT

### Transportation

Transportation systems help ensure that people can reach everyday destinations, such as jobs, schools, healthy food outlets, and healthcare facilities, safely and reliably. Enhanced built environment interventions including sidewalks, bicycle infrastructure, and public transit infrastructure can make physical activity easier, safer, and more accessible.<sup>56</sup> More housing units in Carson City had no vehicles available. Commute times range from 20 minutes in Storey County to 28.6 minutes in Douglas County. Approximately 6.4% of Storey County residents walk to work, a percentage that is much higher than the surrounding service area.

#### Exhibit 89: Access to a Vehicle & Commute Time

	United States	Nevada	CTH PSA	Carson City	Douglas County	Lyon County	Storey County
No vehicles available	8.5%	7.3%	3.3%	5.4%	2.0%	2.8%	1.1%
Travel time to work in minutes	26.9	24.6	24.1	20.0	24.8	28.6	27.9

Source: U.S. Census Bureau, 2016-2020 American Community Survey Five-Year Estimates

#### Exhibit 90: Means of Commuting to Work

	United States	Nevada	CTH PSA	Carson City	Douglas County	Lyon County	Storey County
<b>Workers 16 and over</b>	153,665,654	1,402,593	55,827	25,337	21,060	22,859	1,531
Drove alone	74.9%	76.8%	79.4%	79.4%	75.4%	81.8%	76.3%
Carpooled	8.9%	10.6%	11.7%	11.5%	11.6%	11.9%	7.9%
Public transportation (excluding taxicab)	4.6%	2.9%	0.5%	0.7%	0.1%	0.8%	1.8%
Walked	2.6%	1.6%	1.2%	1.7%	1.6%	1.2%	6.4%
Other means	1.8%	2.3%	1.0%	1.3%	2.0%	0.6%	0.8%
Worked from home	7.3%	5.8%	6.1%	6.5%	9.6%	3.7%	7.0%

Source: U.S. Census Bureau, 2016-2020 American Community Survey Five-Year Estimates

<sup>56</sup> U.S. Department of Health and Human Services, Assistant Secretary for Planning and Evaluation Office of Health Policy. *Addressing Social Determinants of Health: Examples of Successful Evidence-Based Strategies and Current Federal Efforts*, 2022.

## Broadband

Research has shown that investing in broadband infrastructure has social benefits, including better health outcomes and improved job prospects for people in rural areas. In Nevada, rural and tribal communities have less access compared to more densely population areas like Reno or Las Vegas. The lack of access highlights disparities within the Quad-County Region, as historically, Nevada’s 28 tribal nations have experienced a lack of infrastructure funding for decades.<sup>57</sup> Broadband connectivity has also become a key social determinant of health and health equity. Research shows that for many years,

*“The shift of work and school online highlighted the lack of access to high-speed broadband internet service in some parts of the U.S. and intensified political pressure on the government to make it more widely available.”*

*Brookings Institute, 2021*

***“Stakeholders have viewed broadband as a critical means to connect doctors to patients and to close gaps related to time and distance. Unfortunately, many Americans are still falling through the broadband health gap.”<sup>58</sup>***

As restrictions on telehealth loosened during the pandemic, including HIPAA requirements for video-conferencing software and geographic requirements, providers conducted 75.0% of behavioral health visits via telehealth in May and June 2020 for patients with commercial insurance nationwide.<sup>59</sup>

### Exhibit 91: Computers & Internet Use

	United States	Nevada	CTH PSA	Carson City	Douglas County	Lyon County	Storey County
<b>Total households</b>	122,354,219	1,130,011	ND	22,858	21,071	21,726	1,704
With a computer	91.9%	93.6%	93.5%	92.0%	94.4%	93.5%	94.6%
With a broadband Internet subscription	85.2%	85.5%	11.5%	14.6%	9.5%	12.0%	14.1%

Source: U.S. Census Bureau, 2016-2020 American Community Survey Five-Year Estimates

<sup>57</sup> *Governing. Rural Areas in Nevada See Broadband as Key to Progress, 2022.*

<sup>58</sup> *Federal Communications, Advancing Broadband Connectivity as a Social Determinant of Health. Link: fcc.gov/health/SDOH*

<sup>59</sup> *American Hospital Association. Trend Watch: The impacts of the COVID-19 pandemic on behavioral health, 2022. Link: aha.org/system/files/media/file/2022/05/trendwatch-the-impacts-of-the-covid-19-pandemic-on-behavioral-health.pdf*

## QUAD-COUNTY REGIONAL COMMUNITY HEALTH NEEDS ASSESSMENT

### Environmental Health

Polluted air, contaminated water, and extreme heat are three environmental conditions that can negatively impact population health. Location, race and ethnicity, and socioeconomic status affect an individual’s environmental exposures and subsequent risk of negative health outcomes. Reducing harmful environmental exposures can improve population health and may contribute to decreases in health disparities.<sup>60</sup> The Safe Drinking Water Information System contains information about public water systems and their violations of United States Environmental Protection Agency (EPA) drinking water regulations. These regulations establish maximum contaminant levels, treatment techniques, and monitoring and reporting requirements to ensure that water systems provide safe water to their customers.<sup>61</sup>

#### Exhibit 92: Water Violations

	Nevada	Carson City	Douglas County	Lyon County	Storey County
Presence of Water Violation	ND	No	Yes	No	No

Source: United States Environmental Protection Agency, 2020

Below are the test results to date for the Water Infrastructure Improvements for the Nation (WIIN) project testing of lead in drinking water for childcare centers in each county. Results are updated as they are received from the laboratory, beginning in early 2022.

Carson City was the only area within the Quad-County Region with lead levels which required action.

#### About the Data

Parts per billion (ppb) is a measure of the concentration of lead within a water sample. Sources with an initial lead result of 15 and over require that the water source be blocked off and restricted from use until the source of the problem can be identified. All water sources above the action level of 15 ppb will be addressed.

#### Exhibit 93: Lead Testing Results

COUNTY	Initial Lead Result	Source Type	Facility Name	Corrective Action	Corrected Result
Carson City	17 ppb	Classroom Faucet	Child Development Center	Fixture Replaced and Pitcher Filter	2 ppb
	22 ppb	Classroom Faucet	Community Services Agency Carson City Early Head Start	Fixture Replaced	9 ppb

Source: Nevada Division of Environmental Protection. Lead Testing Program, 2022

<sup>60</sup> U.S. Department of Health and Human Services, *Healthy People 2030. Social Determinants of Health Literature Summaries, Environmental Conditions*. Link: [health.gov/healthypeople/priority-areas/social-determinants-health/literature-summaries/environmental-conditions](https://health.gov/healthypeople/priority-areas/social-determinants-health/literature-summaries/environmental-conditions).

<sup>61</sup> United States Environmental Protection Agency, *Drinking Water Violations*. Link: <https://www.countyhealthrankings.org/app/nevada/2022/measure/factors/124/datasource>



## QUAD-COUNTY REGIONAL COMMUNITY HEALTH NEEDS ASSESSMENT

### Education

Education is not only about the schools or higher education opportunities within a community; it includes the languages spoken, literacy, vocational training, and early childhood education.<sup>62</sup>

The Quad-County Region is home to Western Nevada College in Carson City and is near Sierra Nevada College in Washoe County, and the University of Nevada, Reno. Across the counties, the population over 25 with less than a 9<sup>th</sup> grade education ranges from 0.5% of those in Storey County to 4.1% of those in Carson City. Generally, more than eight in ten graduated high school or higher, and proportions of those with a Bachelor's degree or higher range from 13.9% (Lyon) to 33.3% (Storey County).

#### Exhibit 94: Educational Achievement

	United States	Nevada	CTH PSA	Carson City	Douglas County	Lyon County	Storey County
<b>Population 25 and over</b>	222,836,834	2,093,820	94,168	39,827	37,672	40,302	3,055
Less than 9th grade	4.9%	5.3%	3.0%	4.1%	1.7%	3.9%	0.5%
9th to 12th grade, no diploma	6.6%	7.7%	7.1%	7.9%	4.1%	9.2%	5.3%
High school graduate (includes equivalency)	26.7%	27.9%	26.7%	26.6%	23.6%	32.9%	23.6%
Some college, no degree	20.3%	25.1%	28.1%	28.3%	26.8%	29.4%	28.5%
Associate degree	8.6%	8.4%	11.4%	10.3%	11.9%	10.7%	8.8%
Bachelor's degree	20.2%	16.6%	15.8%	15.0%	20.1%	9.7%	23.2%
Graduate or professional degree	12.7%	8.8%	8.0%	7.8%	11.7%	4.2%	10.0%
High school graduate or higher	88.5%	86.9%	89.9%	88.1%	94.2%	86.9%	94.2%
Bachelor's degree or higher	32.9%	25.5%	23.8%	22.9%	31.9%	13.9%	33.3%

Source: U.S. Census Bureau, 2016-2020 American Community Survey Five-Year Estimates

<sup>62</sup> Kaiser Family Foundation. *Beyond Healthcare: The Role of Social Determinants in Promoting Health & Health Equity*, 2018.

## QUAD-COUNTY REGIONAL COMMUNITY HEALTH NEEDS ASSESSMENT

- The percentage of individuals who have a 9<sup>th</sup> to 12<sup>th</sup> grade education without a diploma in Carson City and Lyon County is higher than statewide. The Carson City percentage is also higher than the national percentage.

The trend of students graduating high school have remained steady or slightly declines between the 2019-2019 and 2020-2021 within the Quad-County Region. The COVID-19 pandemic “appears to have blunted some of the progress made over the past decade or so. Many Nevada high school students did not attend in-person classes full time during the 2020-2021 school year, and while virtual learning worked for some students, others struggled.”<sup>63</sup>

**Exhibit 95: Trend of Graduation Rates**

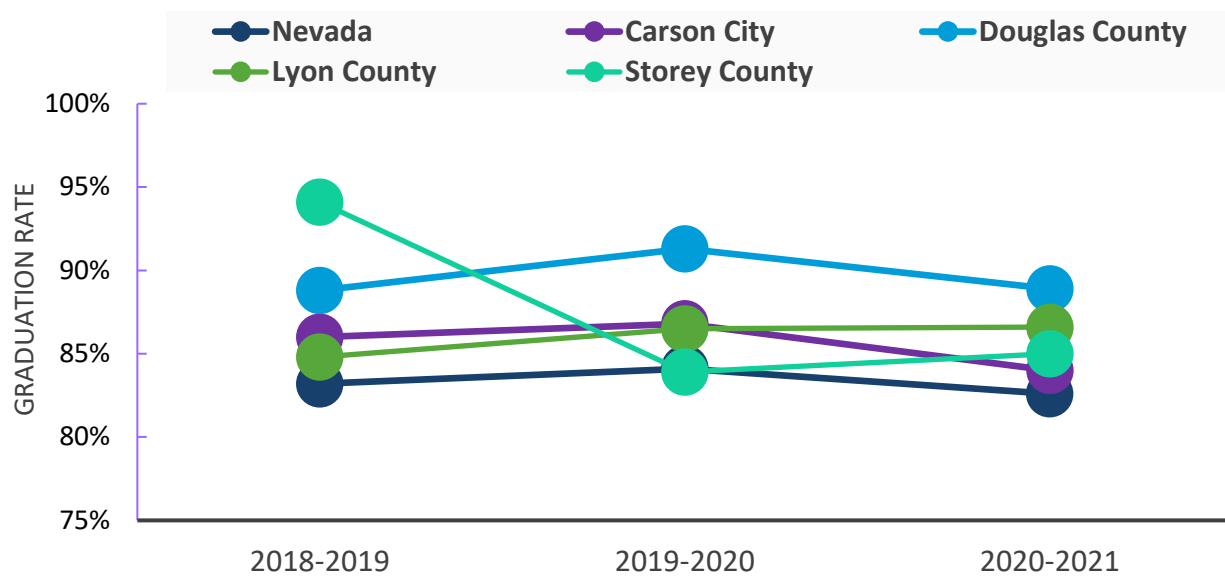

SCHOOL YEAR	Nevada	Carson City	Douglas County	Lyon County	Storey County
2020-2021	82.6%	84.0%	88.9%	86.6%	85.0%
2019-2020	84.1%	86.8%	91.3%	86.5%	83.9%
2018-2019	83.2%	86.0%	88.8%	84.8%	94.1%

Source: State of Nevada Department of Education, Nevada Accountability Portal

- For the 2020-2021 school year, Douglas County has the highest levels of graduation rates (88.9%) across the service area.
- The lowest graduation rate is in Carson City (84.0%). The graduation rate decreased from 86.0% in 2018-2019 to 84.0% in 2020-2021.
- Graduation rates in Storey County decreased from a notable high of 94.1% in 2018-2019 to 85.0% in 2020-2021. The decrease in graduate rates may be due to the COVID-19

<sup>63</sup> Pandemic 'survival mode' complicates students' pathways to graduation, *The Nevada Independent*, 2022.

## QUAD-COUNTY REGIONAL COMMUNITY HEALTH NEEDS ASSESSMENT

pandemic. Lyon County graduation rates increased from 84.8% in 2018-2019 to 86.6% in 2020-2021.

The graph below indicates the percentage of the white and hispanic or latino population who have graduated high school or high education degree.

Lower percentages of Hispanic or Latino individuals have earned a high school graduate or higher within the Quad-County Region than those of other races.

**Exhibit 96: High School Graduate Degree or Higher by Race & Ethnicity**

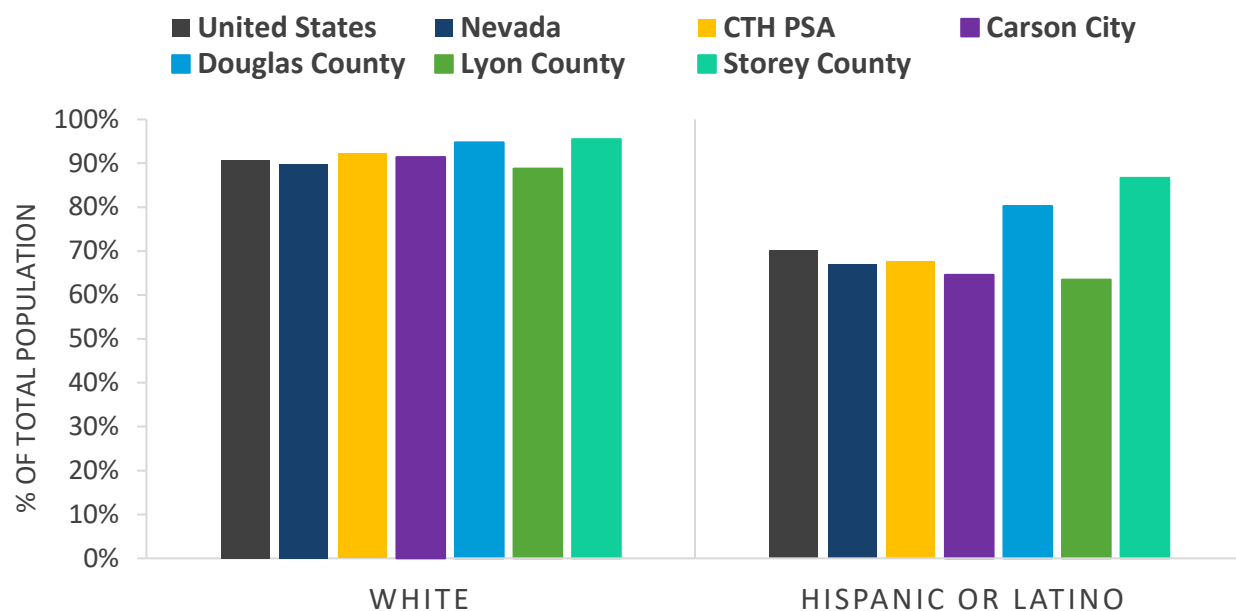

	United States	Nevada	CTH PSA	Carson City	Douglas County	Lyon County	Storey County
White (any ethnicity)	90.7%	89.8%	92.2%	91.4%	94.8%	88.8%	95.5%
Black or African American (any ethnicity)	86.7%	90.0%	75.9%	70.0%	97.2%	89.2%	15.0%
American Indian and Alaskan Native (any ethnicity)	80.6%	81.1%	80.4%	79.7%	79.9%	90.0%	100.0%
Asian (any ethnicity)	87.3%	90.7%	90.7%	88.7%	96.6%	83.3%	100.0%
Native Hawaiian and Other Pacific Islander (any ethnicity)	86.9%	91.6%	100.0%	100.0%	100.0%	100.0%	ND
Some other race alone (any ethnicity)	63.9%	61.2%	58.9%	54.9%	81.7%	57.6%	0.0%
Hispanic or Latino (any race)	70.3%	67.1%	67.7%	64.6%	80.3%	63.5%	86.7%

Source: U.S. Census Bureau, 2016-2020 American Community Survey Five-Year Estimates



## QUAD-COUNTY REGIONAL COMMUNITY HEALTH NEEDS ASSESSMENT

Some children live in places with poorly performing schools, and the stress of living in poverty can affect children’s brain development, making it harder for them to do well in school.<sup>64</sup> The following data utilizes the Nevada Department of Education’s Accountability Portal to provide critical data related to educational success and outcomes.<sup>65</sup>

More fourth grade students in Douglas and Storey counties meet the standard proficiencies for English Language Arts (ELA) compared to the statewide figure, whereas those in Carson City and Lyon County are lower percentages. However, while only 16.2% of students meet the ELA standard proficiencies in Carson City, 22.9% of students exceed the standard proficiencies, higher compared to other service area counties.

### Exhibit 97: Fourth Grade Assessment

2020 2021 SCHOOL YEAR	Nevada	Carson City	Douglas County	Lyon County	Storey County
<b>English Language Arts</b>					
Meets Standard	21.2%	16.2%	32.9%	25.5%	40.3%
Exceeds Standard	19.1%	22.9%	18.0%	9.0%	14.1%
<b>Math</b>					
Meets Standard	19.0%	27.2%	27.2%	16.5%	40.7%
Exceeds Standard	9.2%	9.8%	15.4%	<5%	ND

Source: Nevada Department of Education, Nevada Accountability Portal

### Exhibit 98: Fourth Graders Who Meet Standard by Race & Ethnicity

2020 2021 SCHOOL YEAR	Nevada	Carson City	Douglas County	Lyon County	Storey County
<b>English Language Arts</b>					
American Indian and Alaskan Native	16.1%	22.4%	17.1%	14.9%	ND
Hispanic	18.4%	19.6%	28.4%	24.0%	ND
White	26.6%	27.8%	35.0%	26.6%	40.0%
<b>Math</b>					
American Indian and Alaskan Native	9.4%	ND	ND	ND	ND
Hispanic	13.6%	21.4%	17.9%	19.8%	ND
White	27.4%	35.8%	32.4%	18.8%	ND

Source: Nevada Department of Education, Nevada Accountability Portal

- Fewer students in the Quad-County Region meet or exceed the standard for math when compared to those who meet or exceed the standard for ELA. The proportion of students who meet or exceed the standard for math is greater in Carson City, Douglas County, and Storey County than the state figure.

<sup>64</sup> U.S. Department of Health and Human Services, *Healthy People 2030. Social Determinants of Health, Education Access & Quality.*

<sup>65</sup> Nevada Department of Education, Nevada Accountability Portal. Link: [nevadareportcard.nv.gov/di/](http://nevadareportcard.nv.gov/di/)

## QUAD-COUNTY REGIONAL COMMUNITY HEALTH NEEDS ASSESSMENT

- A greater percentage of fourth graders who identify as white meet both ELA and math standard proficiencies in every service area.

More eighth grade students in the Quad-County Region meet the standard proficiencies for English Language Arts (ELA) compared to the statewide figure, except for Lyon County. The same is true for math standards.

### Exhibit 99: Eighth Grade Assessment

2020 2021 SCHOOL YEAR	Nevada	Carson City	Douglas County	Lyon County	Storey County
<b>English Language Arts</b>					
Meets Standard	26.9%	27.9%	32.9%	25.5%	40.3%
Exceeds Standard	14.5%	11.7%	18.0%	9.0%	14.1%
<b>Math</b>					
Meets Standard	16.6%	18.9%	25.0%	14.9%	23.9%
Exceeds Standard	9.7%	9.3%	12.9%	6.6%	8.8%

Source: Nevada Department of Education, Nevada Accountability Portal

### Exhibit 100: Eighth Graders Who Meet Standard by Race & Ethnicity

2020 2021 SCHOOL YEAR	Nevada	Carson City	Douglas County	Lyon County	Storey County
<b>English Language Arts</b>					
American Indian and Alaskan Native	19.7%	22.4%	17.1%	14.9%	ND
Hispanic	22.9%	23.7%	28.4%	24.0%	ND
White	32.7%	32.3%	35.0%	26.6%	40.0%
<b>Math</b>					
American Indian and Alaskan Native	8.5%	ND	ND	8.5%	ND
Hispanic	12.1%	15.4%	19.8%	12.4%	ND
White	23.0%	22.6%	27.1%	15.7%	23.5

Source: Nevada Department of Education, Nevada Accountability Portal

- White students in the Quad-County Region meet the standards for ELA and math at a higher rate than students who are Hispanic or American Indian and Alaskan Native.

The Quad-County Region has approximately 22,150 students enrolled in public school systems.

### Exhibit 101: Educational System Overview

2020 2021 SCHOOL YEAR	Nevada	Carson City	Douglas County	Lyon County	Storey County
Total Student Enrollment	482,364	7,500	5,385	8,817	448
Number of Schools per District	752	13	17	20	4
Per Public Expenditures <sup>66</sup>	\$9,607	\$11,100	\$11,067	\$10,830	\$16,654

Source: Nevada Department of Education, Nevada Accountability Portal

<sup>66</sup> Some spending comes from Federal funds and some comes from State/Local funds.

## QUAD-COUNTY REGIONAL COMMUNITY HEALTH NEEDS ASSESSMENT

The average number of students in each class in secondary schools for core subjects in Storey County is notably low, at about two or three students per class. Carson City has the highest average class size for core subjects, with an average of 22 students per class.

### Exhibit 102: Average Class Size for Core Subjects

2020 2021 SCHOOL YEAR	Nevada	Carson City	Douglas County	Lyon County	Storey County
Math	24	21	12	18	2
English	22	22	13	16	2
Science	25	23	14	18	3
Social Studies	23	22	13	17	3

Source: Nevada Department of Education, Nevada Accountability Portal

### Exhibit 103: Chronic Absenteeism<sup>67</sup>

	Nevada	Carson City	Douglas County	Lyon County	Storey County
2020-2021 School Year	31.2%	40.9%	16.9%	31.2%	32.9%

Source: Nevada Department of Education, Nevada Accountability Portal

- In the 2020-21 school year, Carson City presents a higher percentage of chronically absent students (40.9%), the percentage of students who miss 10.0% or more of enrolled school days per year either with or without a valid excuse.

<sup>67</sup> Percentage of students who miss 10% percent or more of enrolled school days per year either with or without a valid excuse.

### Individualized Education Program (IEP)

The data below indicates the number of students between the ages of three and 21 enrolled in each district who had an individualized education program (IEP), or a plan developed in accordance with section 504 of the Rehabilitation Act of 1973, 29 U.S.C. § 794 as of October 2021. Section 504 of the Rehabilitation act of 1973, as amended, prohibits discrimination against otherwise qualified individuals on the basis of disability.<sup>68</sup> Please note, that the asterisk (\*) indicates suppressed values in order to protect student privacy.

#### About the Data

IEPs are covered by special education law, or the Individuals with Disabilities Education Act (IDEA). They are created for eligible kids who attend public school, which includes charter schools. IEPs provide individualized special education and related services to meet a child’s unique needs at no cost to families.

Of the select types of disability within the data, most students have a form of specific learning disability within the service area, followed by Autism. Since the Center of Disease Control and Prevention began tracking autism rates in 2000, the rate has more than doubled from one in 150 to one in 59.

**Exhibit 104: Students Enrolled in an IEP Program by Primary Disability Category**

	Nevada	Carson City	Douglas County	Lyon County	Storey County
Autism	9,171	101	61	126	*
Developmental Delay	4,801	66	51	96	*
Emotional Disturbance	2,077	13	*	30	*
Intellectual Disability	2,185	36	26	47	*
Specific Learning Disability	26,448	444	322	405	28
Multiple Disabilities	1,201	26	*	32	*

Source: Nevada Department of Education. Children With Disabilities School Age, 2021

- The Special Education Child Count estimates for overall Autism Spectrum Disorder prevalence in Nevada between 2010 and 2018 has increased from 7.3 per 1,000 children to 14.7 per 1,000 children.<sup>69</sup>

<sup>68</sup> U.S. Department of Health & Human Services Office for Civil Rights.

Link: [hhs.gov/sites/default/files/ocr/civilrights/resources/factsheets/504.pdf](https://hhs.gov/sites/default/files/ocr/civilrights/resources/factsheets/504.pdf)

<sup>69</sup> National Center on Birth Defects and Developmental Disabilities, Centers for Disease Control and Prevention. Link: [cdc.gov/ncbddd/autism/data/index.html#explore](https://cdc.gov/ncbddd/autism/data/index.html#explore)

## QUAD-COUNTY REGIONAL COMMUNITY HEALTH NEEDS ASSESSMENT

### Exhibit 105: Preschool & Nursery Enrollment<sup>70</sup>

	Nevada	Carson City	Douglas County	Lyon County	Storey County
Three to Four Year Olds Enrolled	36.7%	43.5%	41.1%	36.4%	15.7%

Source: U.S. Census Bureau, 2016-2020 American Community Survey Five-Year Estimates

Head Start and Early Head Start programs promote school readiness for economically disadvantaged children by enhancing their social and cognitive development through the provision of educational, health, nutritional, social, and other services. Head Start programs serve children ages three to five and their families. Early Head Start programs serve pregnant women and children birth to three and their families.<sup>71</sup> There are five locations throughout the region, primarily designated as American Indian and Alaska Native Centers.

### Exhibit 106: Quad-County Head Start Locations

County	Center Name	Center
Lyon County	Yerington Center	Migrant and Seasonal Head Start Center
Lyon County	Yerington Head Start	American Indian and Alaska Native Center
Douglas County	Dresslerville	American Indian and Alaska Native Center
Carson City	Stewart	American Indian and Alaska Native Center
Carson City	Carson	Early Head Start Center

Source: U.S. Department of Health & Human Services, Head Start Center Locator



<sup>70</sup> Data for the Carson Tahoe Health service area were based on aggregated data available at the ZIP Code level. For some measures, ZIP Code data was not available, so some CTH data points are omitted.

<sup>71</sup> State of Nevada Department of Education, Head Start Program.

## Food Access

Exhibit 5: U.S. Department of Agriculture Food Environment Factors<sup>72</sup>



## Food Insecurity

Food insecurity is defined as the disruption of food intake or eating patterns because of a lack of money and other resources. Food insecurity may be long-term or temporary. It may be influenced by several factors including income, employment, race/ethnicity, and disability. The risk for food insecurity increases when money to buy food is limited or not available. People living in some urban areas, rural areas, and low-income neighborhoods may have limited access to full-service supermarkets or grocery stores.<sup>73</sup> The pandemic impacted access to nutritious foods for vulnerable populations and communities that had not experienced food insecurity prior to 2020.<sup>74</sup>

<sup>72</sup> U.S. Department of Agriculture Food Environment Atlas. Link: [ers.usda.gov/data-products/food-environment-atlas/about-the-atlas/](https://ers.usda.gov/data-products/food-environment-atlas/about-the-atlas/)

<sup>73</sup> U.S. Department of Health and Human Services, Healthy People 2030. Social Determinants of Health Literature Summaries, Food Insecurity. Link: [health.gov/healthypeople/priority-areas/social-determinants-health/literature-summaries/food-insecurity#cit1](https://health.gov/healthypeople/priority-areas/social-determinants-health/literature-summaries/food-insecurity#cit1)

<sup>74</sup> Feeding America. The Impact Of The Coronavirus On Food Insecurity In 2020 & 2021, March 2021. Link: [feedingamerica.org/sites/default/files/2021-03/National\\_Projections\\_Brief\\_3.9.2021\\_0.pdf](https://feedingamerica.org/sites/default/files/2021-03/National_Projections_Brief_3.9.2021_0.pdf)

## QUAD-COUNTY REGIONAL COMMUNITY HEALTH NEEDS ASSESSMENT

Between 2019 and 2021, the overall food insecurity rate and child food insecurity rate increased in all service area counties. Storey County experienced the greatest increase in food insecurity (+1.8%), as well as the greatest increase in the child food insecurity rate (+2.7%).

Additional food access data including food deserts and maps can be found in the Appendices of this report.

### Exhibit 107: Food Insecurity

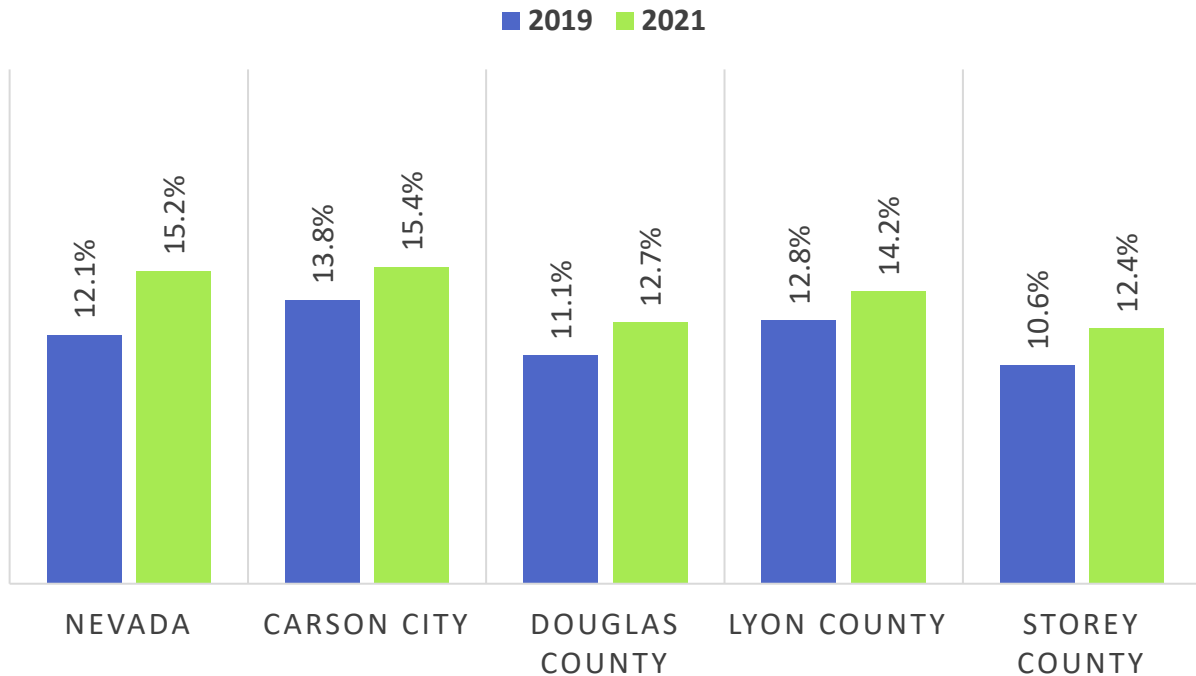

	Nevada		Carson City		Douglas County		Lyon County		Storey County	
	2019	2021	2019	2021	2019	2021	2019	2021	2019	2021
Food Insecurity Rate	12.1%	15.2%	13.8%	15.4%	11.1%	12.7%	12.8%	14.2%	10.6%	12.4%
Child Food Insecurity Rate	17.7%	23.0%	19.3%	21.9%	16.2%	18.7%	18.9%	21.2%	20.0%	22.7%

Source: Feeding America, Map the Meal Gap

## QUAD-COUNTY REGIONAL COMMUNITY HEALTH NEEDS ASSESSMENT

The white non-Hispanic population in each county and statewide face less food insecurity compared to those identifying as Hispanic or Latino as rates generally twice as high for Hispanic or Latino residents.

**Exhibit 108: Food Insecurity Rates by Ethnicity**

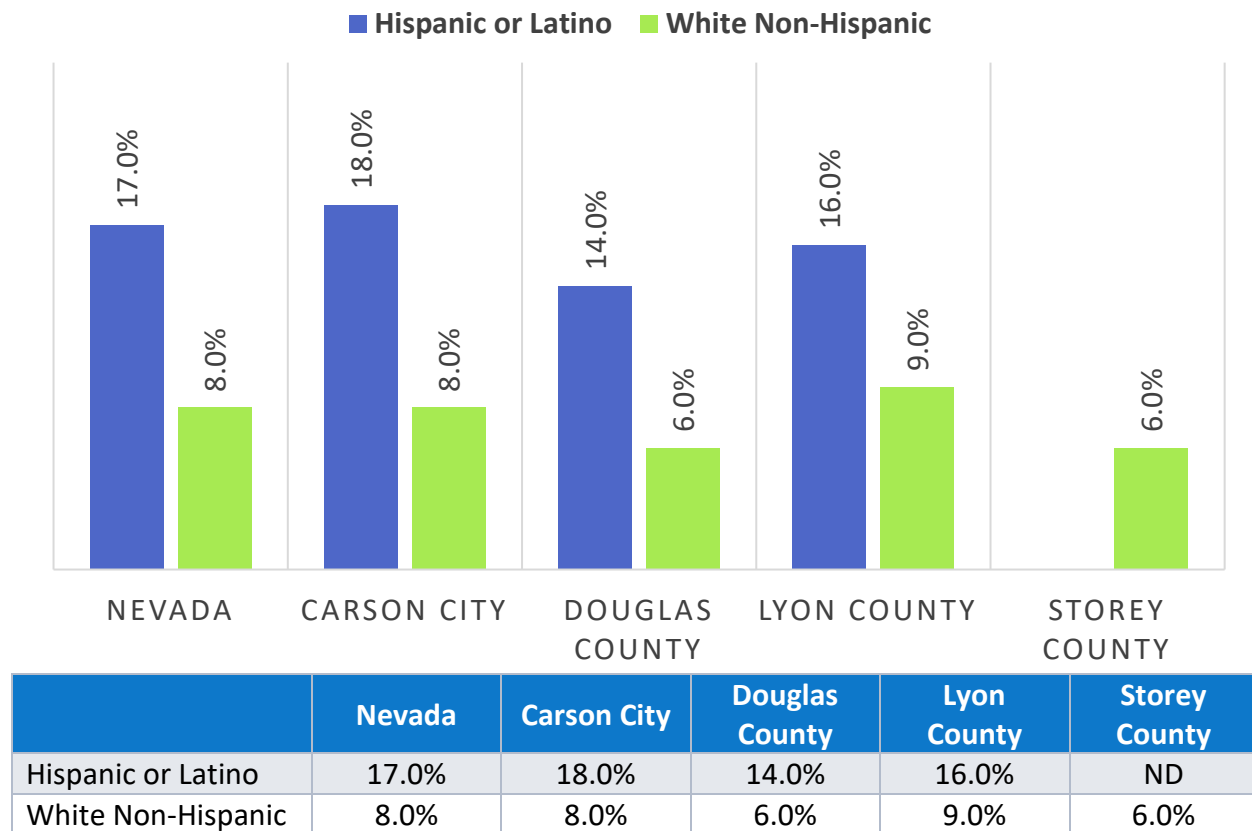

Source: Feeding America, Map the Meal Gap

Limited access to healthy food indicates the population who are low-income and do not live close to a grocery store based on the U.S. Department of Agriculture Food Environment Atlas and three broad categories of factors seen below.

Nearly 13.0% of the low-income population in Douglas County does not live in close proximity to a grocery store, which indicates a more limited environment for residents trying to access healthy foods.

**Exhibit 109: Limited Access to Healthy Food**

	Nevada	Carson City	Douglas County	Lyon County	Storey County
	5.4%	5.2%	12.5%	8.7%	1.2%

Source: U.S. Department of Agriculture Food Environment Atlas, 2019



## QUAD-COUNTY REGIONAL COMMUNITY HEALTH NEEDS ASSESSMENT

Because of the pandemic, the National School Breakfast and Lunch Program for Nevada was free for all students for the 2021-2022 school year. Some of these options have begun to expire, so many schools cannot serve all meals free anymore. Instead, families will do what they did prior to COVID-19.<sup>75</sup> Lyon County has the highest percentage of students that are eligible for free and reduced lunch (45.1%), followed by Carson (43.4%).

### Exhibit 110: Students Qualifying for Free or Reduced Lunch Programs

	Nevada	Carson City	Douglas County	Lyon County	Storey County
Students eligible for free and reduced lunch	275,161	3,381	1,642	3,507	138
Percent of students eligible for free and reduced lunch	64.9%	43.4%	30.7%	45.1%	31.2%

Source: Nevada Department of Agriculture, National School Lunch Program. Free & Reduced Lunch Reports, 2021

### Exhibit 111: Fruits & Vegetable Consumption

	Nevada	Carson City	Douglas County	Lyon County	Storey County
High school students who ate vegetables 3x or more a day <sup>76</sup>	5.1%	6.8%	4.4%	ND	ND

Source: State of Nevada, Division of Public and Behavioral Health and the University of Nevada, Reno. 2019 Nevada High School Youth Risk Behavior Survey Report

The Supplemental Nutrition Assistance Program (SNAP) helps low-income people buy the food they need for good health. Most SNAP applicants must not have more than the gross and net income limits.

In 2020, Carson City has the highest percentage of residents in the Quad-County Region that are enrolled in the Supplemental Nutrition Assistance Program (SNAP). Storey County has a notably low percentage (1.8%) of residents enrolled in SNAP, as enrollment has decreased since 2018.

### Exhibit 112: Trend of Individuals Enrolled in the Supplemental Nutrition Assistance Program

	Nevada	Carson City	Douglas County	Lyon County	Storey County
2020	456,958	6,749	2,737	6,615	78
2018	448,045	7,702	2,615	6,553	114
2016	451,954	7,805	2,742	6,591	101

University of Nevada Reno, School of Medicine Office of Statewide Initiatives. Nevada Division of Welfare and Supportive Services. Nevada Department of Health and Human Services, Supplemental Nutrition Assistance Program

<sup>75</sup> USDA. School Meal Changes are Coming in the 2022-2023 School Year, 2022. Link: [fns.usda.gov/cn/2022-23-parent-faqs](https://fns.usda.gov/cn/2022-23-parent-faqs)

<sup>76</sup> Douglas County includes Lyon and Storey County schools. Percentage of high school students who ate vegetables three or more times/day during the 7 days before the survey according to the Nevada, Youth Risk Behavior Survey, 2019. Vegetables: Green salad, potatoes (excluding French fries, fried potatoes, or potato chips), carrots, or other vegetables.

## QUAD-COUNTY REGIONAL COMMUNITY HEALTH NEEDS ASSESSMENT

**Exhibit 113: Trend of the Percent of the Population Enrolled in the SNAP**

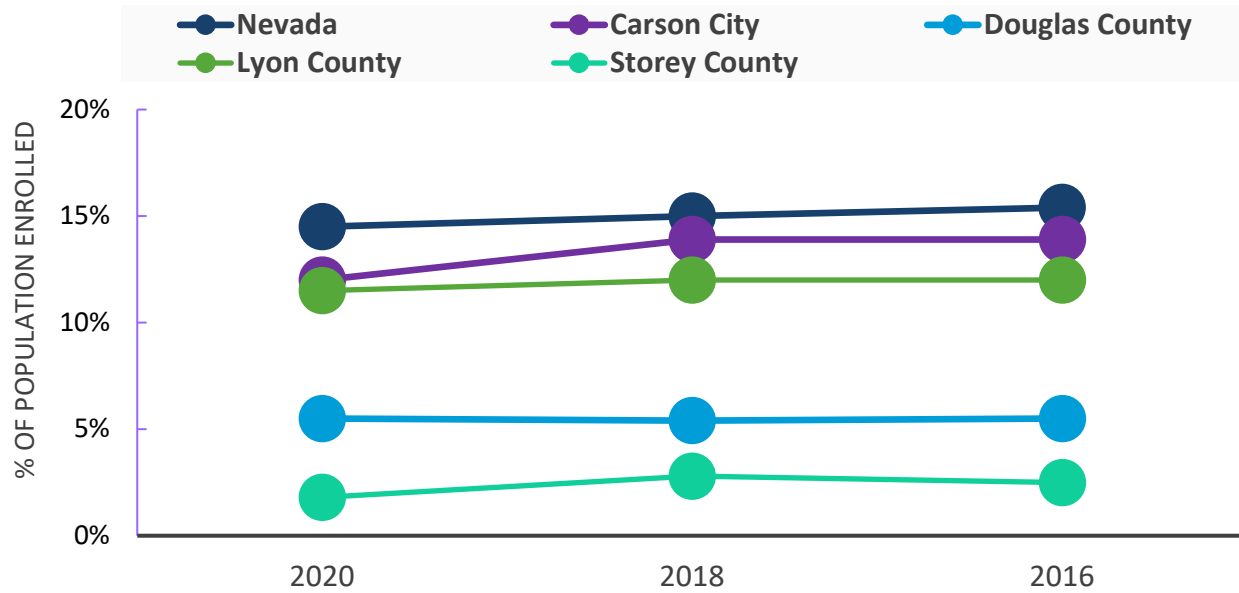

	Nevada	Carson City	Douglas County	Lyon County	Storey County
2020	14.5%	12.0%	5.5%	11.5%	1.8%
2018	15.0%	13.9%	5.4%	12.0%	2.8%
2016	15.4%	13.9%	5.5%	12.0%	2.5%

University of Nevada Reno, School of Medicine Office of Statewide Initiatives. Nevada Division of Welfare and Supportive Services. Nevada Department of Health and Human Services, Supplemental Nutrition Assistance Program

**Exhibit 114: Supplemental Nutrition Assistance Program Enrollment**

	United States	Nevada	Carson City	Douglas County	Lyon County	Storey County
<b>Population enrolled in SNAP</b>	ND	456,958	6,749	2,737	6,615	78
Percent of population enrolled in SNAP	ND	14.5%	12.0%	5.5%	11.5%	1.8%

Source: University of Nevada Reno, School of Medicine Office of Statewide Initiatives. Nevada Division of Welfare and Supportive Services. Nevada Department of Health and Human Services, Supplemental Nutrition Assistance Program, 2020

## Food Deserts

The maps below indicate low-income census tracts where a significant number or share of residents is more than a half mile or from a grocery store, or 10 miles in rural tracts. In Carson City one census tracts are considered low-income and at least a half mile away from a grocery store (Tract 32510). Douglas County presents a fairly large census tract as well (Tract 320050). Storey and Lyon County did not have any reported food deserts.

**Exhibit 115: Quad-County Region Food Deserts**

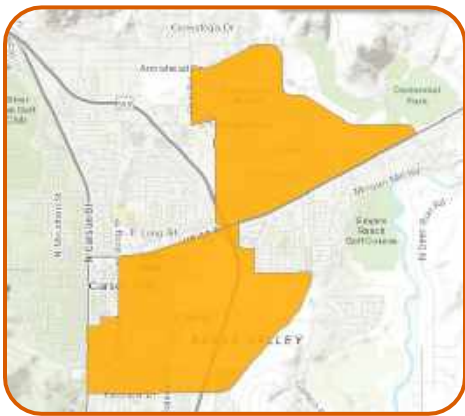

**Carson City**



**Douglas County**

Source: U.S. Department of Agriculture. Food Access Research Atlas

### Food Deserts

Census tracts qualify as food deserts if they meet low-income and low-access thresholds.

#### Low Income.

A poverty rate of 20% or greater, or a median family income at or below 80% of the statewide or metropolitan area median family income.

#### Low Access.

At least 500 persons and/or at least 33% of the population lives more than 1/2 mile from a supermarket or large grocery store (10 miles, in the case of rural census tracts).

*USDA, Mapping Food Deserts in the United States*

## Community & Social Context

Community and social context refer to the support systems and community engagement, including discrimination, non-profits, and social integration. People’s relationships and interactions with family, friends, co-workers, and community members can have a major impact on their health and well-being. Positive relationships at home, at work, and in the community can help reduce negative impacts caused by challenges people cannot control, like unsafe neighborhoods, discrimination, or trouble affording the things they need. However, some people, for example children whose parents are in jail and adolescents who are bullied, often do not get support from loved ones or others.<sup>77</sup>

---

<sup>77</sup> U.S. Department of Health and Human Services, *Healthy People 2030. Social Determinants of Health, Social & Community Context.*

## QUAD-COUNTY REGIONAL COMMUNITY HEALTH NEEDS ASSESSMENT

### Tribal Nations

In Nevada, there are 20 federally recognized tribes, comprised of 27 separate reservations, bands, colonies, and community councils.<sup>78</sup>

The Quad-County Region was built surrounding four major Tribal Nation lands, including the Washoe Tribe in Douglas County, Pyramid Lake Indian Reservation in parts of Lyon and Storey counties, the Yerington Reservation and Trust Lands and the Walker River Indian Reservation in Lyon County.

**Exhibit 116: Map of American Indian & Alaskan Native Land**



Source: United States Environmental Protection Agency, USEPA Air Quality Analysis Maps, Nevada Tribal Lands

**Exhibit 117: Map of American Indian & Alaskan Native Population**

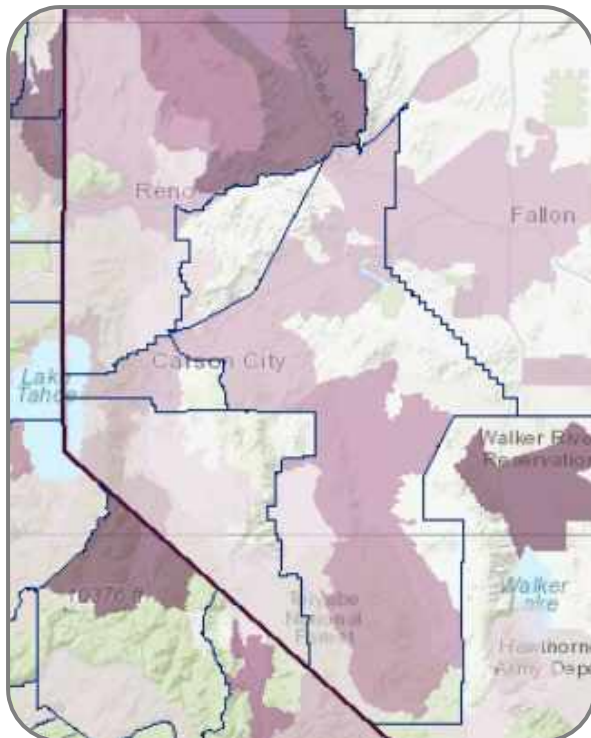

Source: UDS Mapper. American Community Survey (ACS) 2015-2019 five-year estimates

<sup>78</sup> Nevada Indian Commission. Nevada's Great Basin Tribes, 2019.

## QUAD-COUNTY REGIONAL COMMUNITY HEALTH NEEDS ASSESSMENT

### Veteran Community

According to the Veterans Health Administration, the veteran population is projected to decline in every county between 2021 and 2031 and consequently the veteran population in Nevada is projected to decrease by more than 13%.<sup>79</sup> This downward trend is clear in the data, as the number and percentage of veterans in each county has steadily declined. Lyon County presently has the largest veteran population, making up 10.6% of the county population.

**Exhibit 118: Trend of Veteran Population**

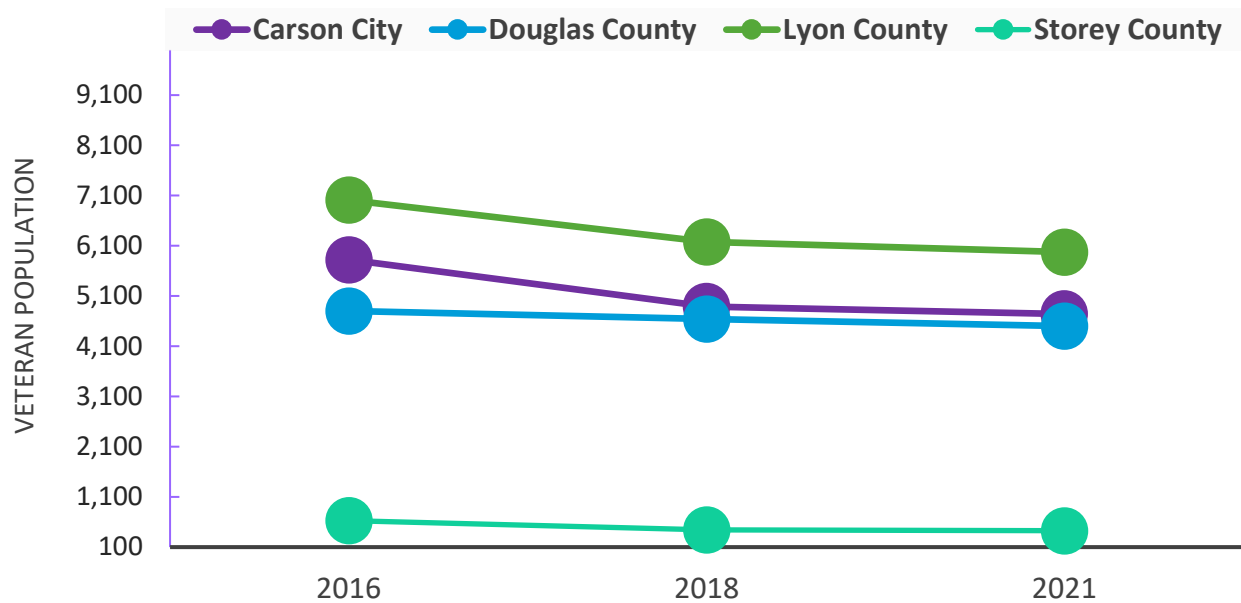

	Nevada	Carson City	Douglas County	Lyon County	Storey County
2021	195,573	4,741	4,501	5,975	427
2018	206,228	4,890	4,645	6,179	444
2016	221,927	5,824	4,802	7,010	627

Source: University of Nevada, Reno School of Medicine's Office of Statewide Initiatives, Nevada Instant Atlas. United States Department of Veterans Health Administration

**Exhibit 119: Veteran Population**

	Nevada	Carson City	Douglas County	Lyon County	Storey County
Percent of all Veterans in Nevada	100.0%	2.4%	2.3%	3.1%	0.2%
Percent of Population	6.2%	8.6%	9.0%	10.6%	9.3%

Source: University of Nevada, Reno School of Medicine's Office of Statewide Initiatives, Nevada Instant Atlas. United States Department of Veterans Health Administration, 2021

<sup>79</sup> Source: University of Nevada Reno School of Medicine Office of Statewide Initiatives. Nevada Rural & Frontier Health Data Book, 2021.

## QUAD-COUNTY REGIONAL COMMUNITY HEALTH NEEDS ASSESSMENT

**Exhibit 120: Percent of Veterans Aged 18 & Older**

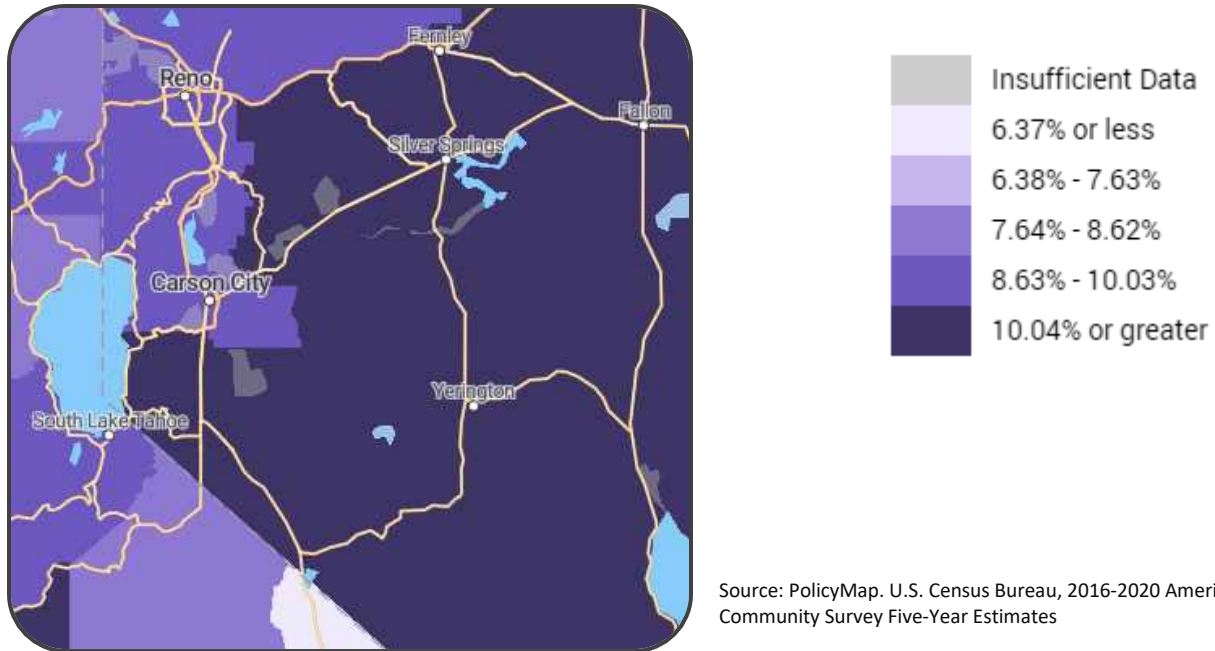

Nevada Department of Veterans Services operates nationally recognized facilities across the state including Southern Nevada State Veterans Home in Boulder City, and our Northern Nevada State Veterans Home in Sparks.<sup>80</sup> Naturally, more veterans in Lyon County are enrolled in the VA healthcare system.

**Exhibit 121: Veterans Assistance Healthcare System**

	Nevada	Carson City	Douglas County	Lyon County	Storey County
<b>Total VA enrollees</b>	76,046	1,924	1,716	2,758	65
VA enrollees as a percent of the veteran population	37.6%	39.7%	37.3%	45.1%	14.8%

Source: University of Nevada, Reno School of Medicine's Office of Statewide Initiatives, Nevada Instant Atlas. United States Department of Veterans Health Administration, 2019

- Lyon County has the highest percentage of VA enrollees as a percent of the veteran population.

<sup>80</sup> Nevada Department of Veterans Services. Link: [veterans.nv.gov](http://veterans.nv.gov)



# QUAD-COUNTY REGIONAL COMMUNITY HEALTH NEEDS ASSESSMENT

## Exhibit 122: Veteran’s Health Administration Facilities

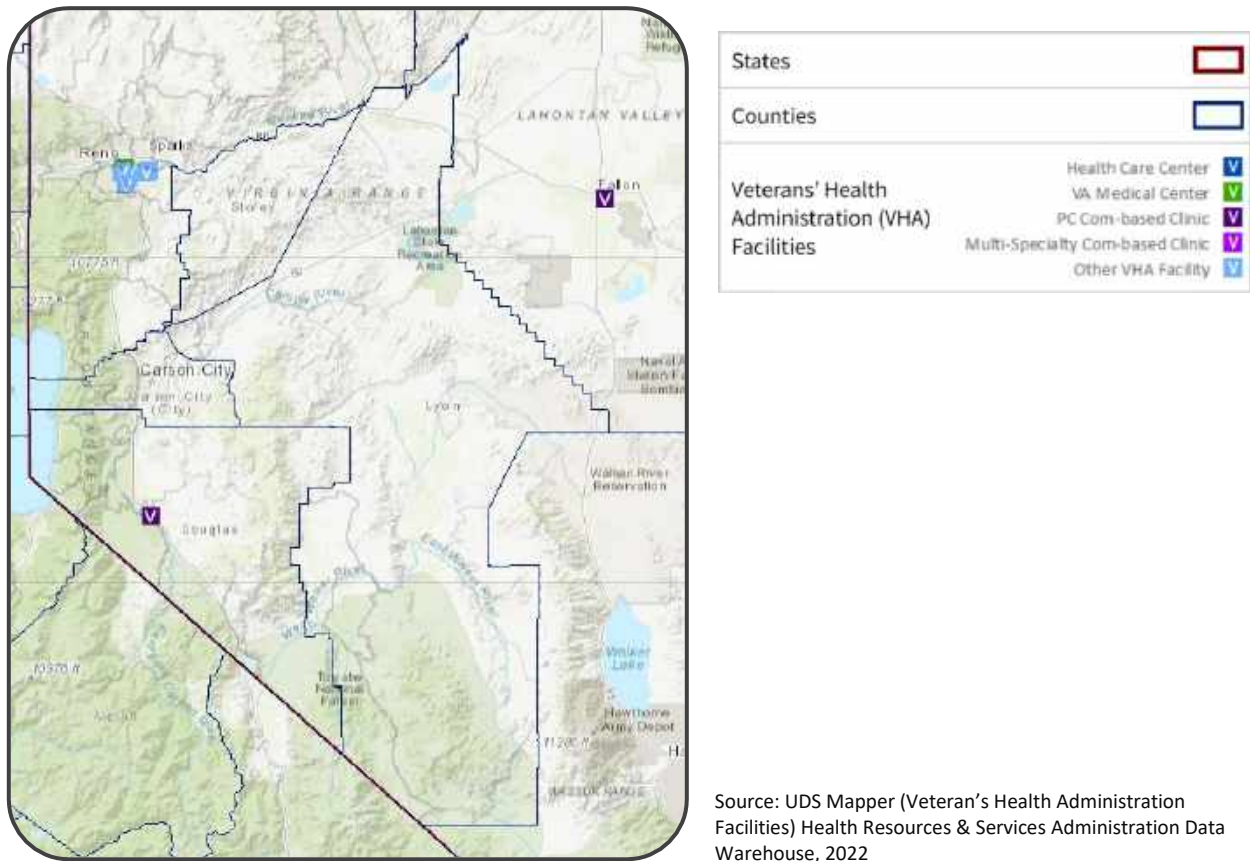

- The map displays the location of all Veterans Health Administration (VA) Facilities by type including healthcare centers, VA medical center, primary care community-based outpatient clinics, multi-specialty community-based outpatient clinics, and other VA health facilities.



## Violent Crime

People who survive violent crimes endure physical pain and suffering and may also experience mental distress and reduced quality of life. Repeated exposure to crime and violence may be linked to an increase in negative health outcomes. Children and adolescents exposed to violence are at risk for poor long-term behavioral and mental health outcomes regardless of whether they are victims, direct witnesses, or hear about the crime.<sup>81</sup>

### About the Data

The data below indicates counts as reported number of violent crimes while rate indicates the number of cases per 100,000 population.

The dramatic increase of reported violent crime in Storey County is skewed because of the relatively smaller population compared to other counties within the Quad-County Region.

As seen in the data below, Storey County had the smallest number of violent crimes.

Violent crime includes murder, rape, aggravated assault, and robbery.<sup>82</sup> Please note, one crime is counted for each victim.<sup>83</sup> Between 2017 and 2021, the rate of violent crimes decreased in all counties, with the exception of Storey County. Statewide, the violent crime rate increased from 373.3 crimes per 100,000 residents to 414.7.

---

<sup>81</sup> U.S. Department of Health and Human Services, *Healthy People 2030. Social Determinants of Health Literature Summaries, Crime & Violence.* Link: [health.gov/healthypeople/priority-areas/social-determinants-health/literature-summaries/crime-and-violence](https://health.gov/healthypeople/priority-areas/social-determinants-health/literature-summaries/crime-and-violence)

<sup>82</sup> Nevada Crime Statistics. *Violent Crime, 2021.* Link: [nevadacrimestats.nv.gov/tops](https://nevadacrimestats.nv.gov/tops)

<sup>83</sup> Nevada Crime Statistics. *Violent Crime, 2021.* Link: [nevadacrimestats.nv.gov/tops](https://nevadacrimestats.nv.gov/tops)

## QUAD-COUNTY REGIONAL COMMUNITY HEALTH NEEDS ASSESSMENT

### Exhibit 123: Trend of Reported Violent Crimes

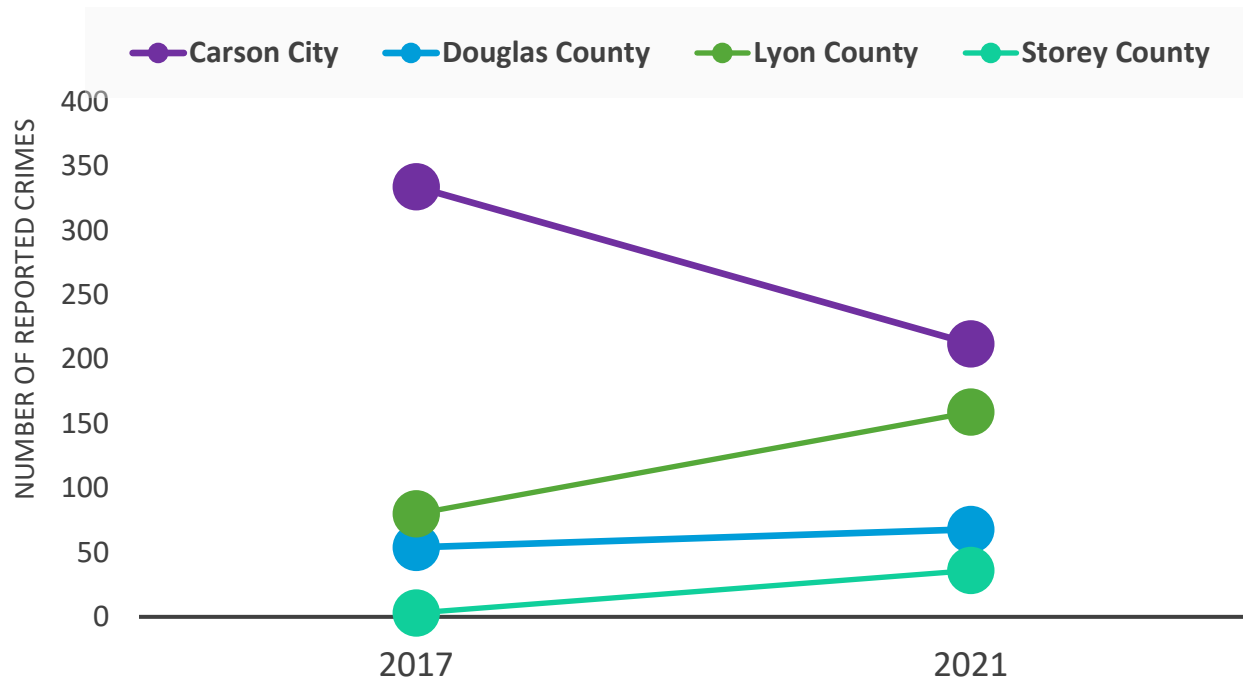

	Nevada		Carson City		Douglas County		Lyon County		Storey County	
	#	Rate	#	Rate	#	Rate	#	Rate	#	Rate
2021	13,014	414.7	212	378.3	68	138.5	159	272.6	36	855.7
2017	11,161	373.7	334	603.2	54	186.6	80	147.0	3	72.9

Source: Nevada Annual Reports of Accountability, Nevada Department of Education

As mentioned above, Storey County had the lowest number of violent crimes in 2021 within the service area, followed by Douglas County. Within the Quad-County Region, aggravated assault was the leading type of violent crime (475 total), followed by rape (114).

### Exhibit 124: Number of Reported Violent Crimes by Type

	Nevada	Carson City	Douglas County	Lyon County	Storey County	Quad County Total
<b>Number of Violent Crime Offenses</b>	<b>13,034</b>	<b>212</b>	<b>68</b>	<b>159</b>	<b>36</b>	<b>475</b>
Aggravated Assault	8,654	144	35	120	29	328
Homicide	233	1	2	0	3	6
Rape	1,854	55	27	30	2	114
Robbery	2,273	12	4	9	2	27

Source: University of Nevada, Reno School of Medicine's Office of Statewide Initiatives, Nevada Instant Atlas. Nevada Department of Public Safety, 2021

## Domestic Violence

### Exhibit 125: Domestic Violence & Crimes Against the Elderly in Nevada

#### Total number of cases

30,423

Cases where medical attention was needed

4,923

Number of children present

15,889

Domestic violence is defined as,

*“The use, attempted use, or threatened use of physical force, or a weapon; or the use of coercion or intimidation; or committing a crime against property by a current or former spouse, parent, or guardian of the victim; a person with whom the victim shares a child in common; a person who is or has been in a social relationship of a romantic or intimate nature with the victim; a person who is cohabiting with or has cohabited with the victim as a spouse, parent, or guardian; or by a person who is or has been similarly situated to a spouse, parent, or guardian of the victim.”*

*Nevada Crime Statistics.  
Domestic & Elderly Crimes 2021*

## QUAD-COUNTY REGIONAL COMMUNITY HEALTH NEEDS ASSESSMENT

Victims of domestic violence and crimes against the elderly were most common among females and males between the ages of 25 to 34 in Nevada as of 2021. Although men do experience domestic violence as well, the data indicates females are more likely to be victims.

**Exhibit 126: Victims of Domestic Violence & Crimes Against the Elderly in Nevada**

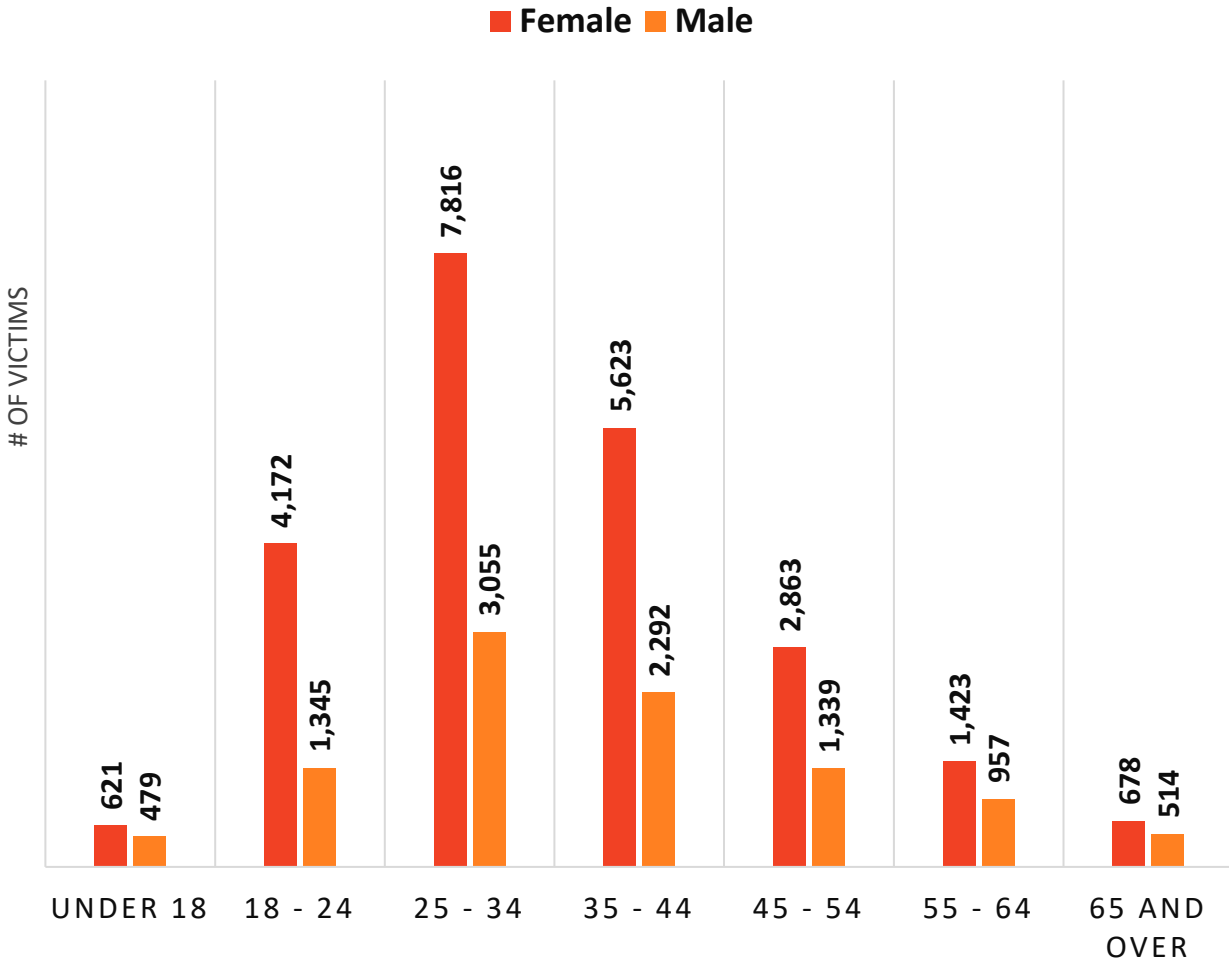

Source: Nevada Crime Statistics. Domestic & Elderly Crimes, 2021

## QUAD-COUNTY REGIONAL COMMUNITY HEALTH NEEDS ASSESSMENT

Males are more likely to be domestic violence offenders compared to women in Nevada, especially men between the ages of 25 and 34.

**Exhibit 127: Offendants of Domestic Violence & Crimes Against the Elderly in Nevada**

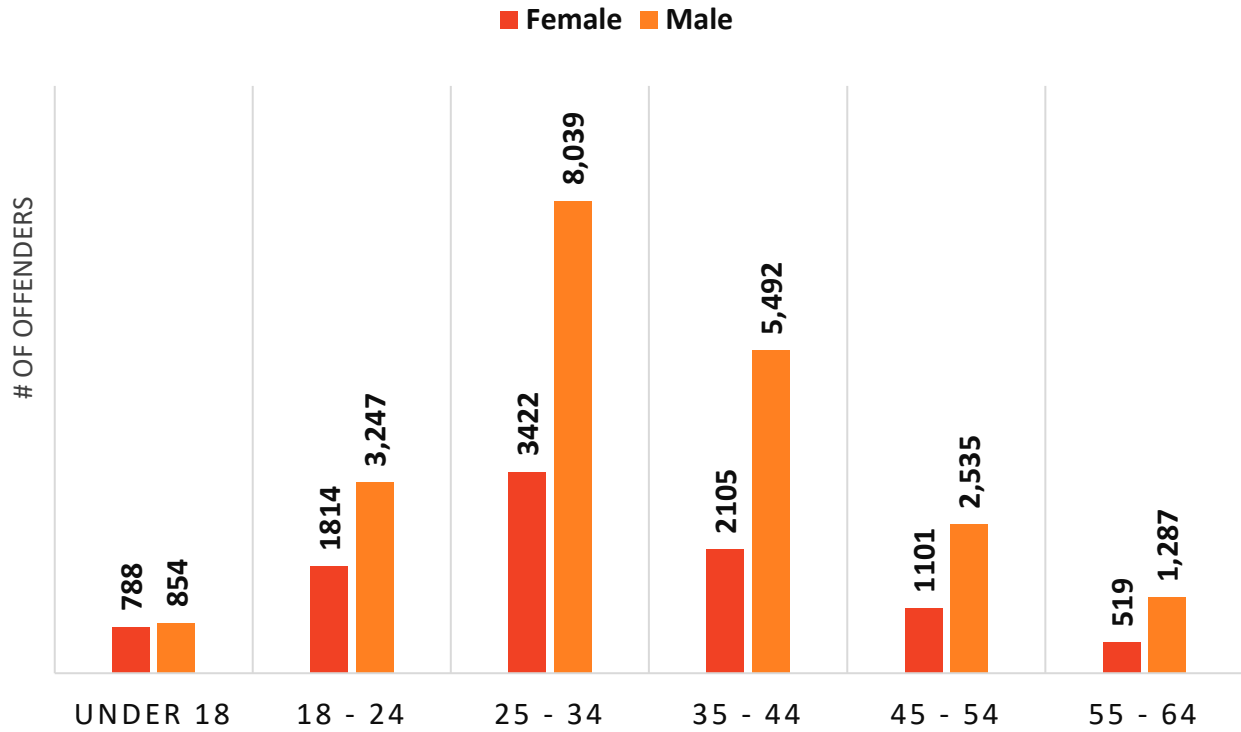

Source: Nevada Crime Statistics. Domestic & Elderly Crimes, 2021

## Property Crime

Crimes against property include burglary, motor vehicle theft, larceny and arson. Victims are always counted individually though there could be multiple victims / offenders per crime.<sup>84</sup> Please note, one crime is counted for each victim.<sup>85</sup> Between 2017 and 2021, the rate of property crimes decreased in all counties, except for Lyon County, which increased by 7.9%. Storey County’s property crime decreased during this period by approximately 31.5%.

**Exhibit 128: Trend of Reported Property Crimes**

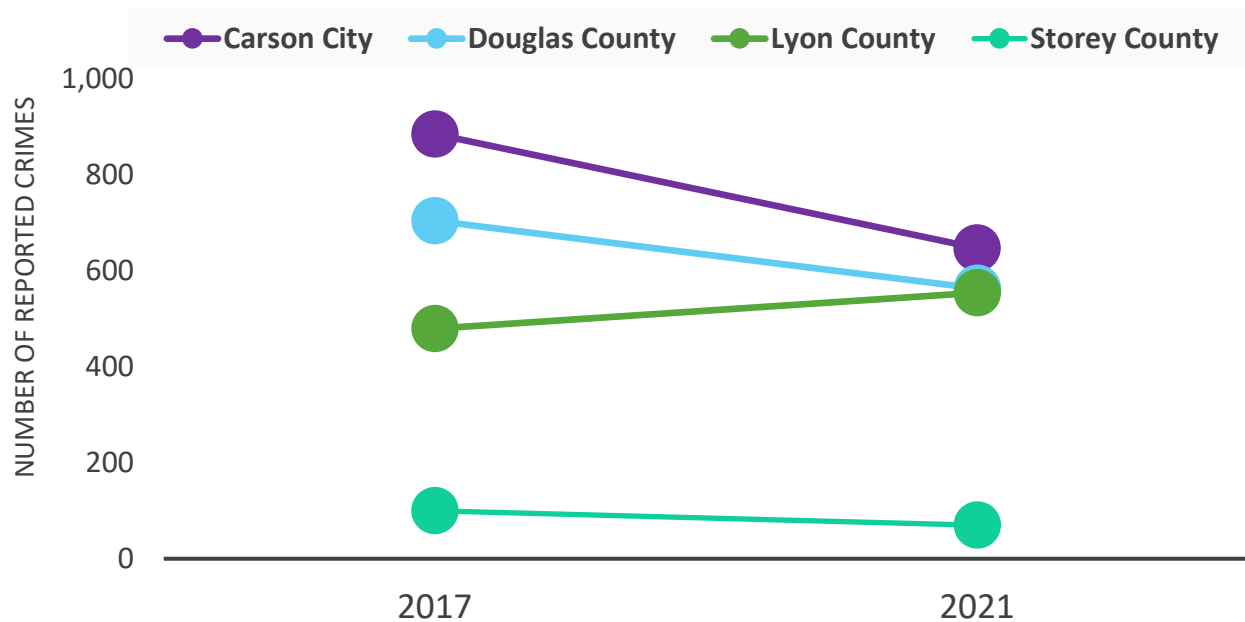

	United States		Nevada		Carson City		Douglas County		Lyon County		Storey County	
	#	Rate	#	Rate	#	Rate	#	Rate	#	Rate	#	Rate
2021	ND	ND	69,459	2,213.3	648	1,156.4	564	1,149.0	555	951.7	70	1,663.9
2017	ND	2,362.0	62,217	2,612.4	886	1,594.5	705	1,450.4	480	882.0	100	2,430.1

Source: University of Nevada. Reno School of Medicine Office of Statewide Initiatives. Nevada Annual Reports of Accountability, Nevada Department of Education

<sup>84</sup> Nevada Crime Statistics. Property Crime, 2021. Link: [nevadacrimestats.nv.gov/tops/report/property-crimes/douglas-county/2021](https://nevadacrimestats.nv.gov/tops/report/property-crimes/douglas-county/2021)

<sup>85</sup> Nevada Crime Statistics. Violent Crime, 2021. Link: [nevadacrimestats.nv.gov/tops](https://nevadacrimestats.nv.gov/tops)

## QUAD-COUNTY REGIONAL COMMUNITY HEALTH NEEDS ASSESSMENT

Within the Quad-County Region, larceny-theft (occurs when property is taken unlawfully without force) was the leading type of property crime (1,314 total), followed by burglary (293).

**Exhibit 129: Number of Reported Property Crimes by Type**

	Nevada	Carson City	Douglas County	Lyon County	Storey County	Quad County Total
Number of Property Crime Offenses	69,459	648	564	555	70	1,837
Arson	456	6	5	9	2	22
Burglary	12,703	106	60	110	17	293
Motor-Vehicle Theft	13,465	86	36	80	6	208
Larceny-theft	42,835	450	463	356	45	1,314

Source: University of Nevada, Reno School of Medicine's Office of Statewide Initiatives, Nevada Instant Atlas. Nevada Annual Reports of Accountability, Nevada Department of Education, 2021

## Workplace Injuries

In 2020, Private industry employers reported 29,800 nonfatal workplace injuries and illnesses in Nevada resulting in an incidence rate of 3.2 cases per 100 full-time equivalent workers.<sup>86</sup> This rate is higher compared to the United States figure.

### About the Data

Incidence rates represent the number of injuries and illnesses per 100 full-time workers working 40 hours per week, 50 weeks per year.

### Exhibit 130: Workplace Injuries in Nevada



Of the 29,800 private industry injury and illness cases reported in Nevada, 18,500 were of a more severe nature, involving days away from work, job transfer, or restriction—commonly referred to as DART cases.



These cases occurred at a rate of 2.0 cases per 100 full-time workers. Fifty-nine percent of the DART cases in Nevada were incidents that resulted in at least one day away from work, compared to 69.1 percent nationally.



Other recordable cases (those not involving days away from work, job transfer, or restriction) accounted for the remaining 11,300 cases in Nevada, at a rate of 1.2. In comparison, the national rate for other recordable cases was 1.0.

Source: U.S. Bureau Of Labor Statistics. Employer-Reported Workplace Injuries & Illnesses in Nevada, 2020

### Exhibit 131: Nonfatal Occupational Injuries & Illnesses In Private Industry

PER 100,000 POPULATION	United States	Nevada
<b>Overall Rate</b>	2.7	3.2
Cases with days away from work, job transfer, or restriction	1.7	2.0
Cases with days away from work	1.2	1.2
Cases with job transfer or restriction	0.5	0.8

Source: U.S. Bureau Of Labor Statistics. Employer-Reported Workplace Injuries & Illnesses in Nevada, 2020

<sup>86</sup> U.S. Bureau Of Labor Statistics. Employer-Reported Workplace Injuries & Illnesses in Nevada, 2020. Link: [bls.gov/regions/west/news-release/workplaceinjuriesandillnesses\\_nevada.htm#SOII\\_TableANevada.xlsx.f.1](https://bls.gov/regions/west/news-release/workplaceinjuriesandillnesses_nevada.htm#SOII_TableANevada.xlsx.f.1)



## QUAD-COUNTY REGIONAL COMMUNITY HEALTH NEEDS ASSESSMENT

In 2020, there were nearly 11,000 nonfatal occupational injuries and illnesses involving days away from work. Most injuries were sustained by workers between the ages of 25 to 54, and predominantly male.

### Exhibit 132: Number of nonfatal Occupational Injuries & Illnesses Involving Days Away From Work

PRIVATE INDUSTRY	Nevada
<b>Total Non-fatal Occupational Injuries</b>	<b>10,970</b>
Male	56.3%
Female	43.3%
<b>Age</b>	
14 to 15	0.0%
16 to 19	1.9%
20 to 24	8.3%
25 to 34	21.4%
35 to 44	20.8%
45 to 54	20.4%
55 to 64	17.9%
65 and over	8.7%
<b>Race &amp; Ethnicity</b>	
White	15.9%
African American or Black	8.9%
Asian	3.8%
Native Hawaiian or other Pacific Islander	0.9%
Multi-race	0.3%
Hispanic or Latino	20.9%
Not reported	49.2%

Source: U.S. Bureau Of Labor Statistics. Employer-Reported Workplace Injuries & Illnesses in Nevada, 2020

## Healthcare System

To understand the healthcare system of communities, multiple factors including provider availability, provider linguistic and cultural competency, quality of care must be recognized.

## Uninsured Population

Inadequate health insurance coverage is one of the largest barriers to healthcare access, and the unequal distribution of coverage contributes to disparities in health. Out-of-pocket medical care costs may lead individuals to delay or forgo needed care (such as doctor visits, dental care, and medications), and medical debt is common among both insured and uninsured individuals. Additionally, primary care providers offer a usual source of care, early detection, and treatment of disease, chronic disease management, and preventive care. Patients with a usual source of care are more likely to receive recommended preventive services such as flu shots, blood pressure screenings, and cancer screenings.<sup>87</sup>

Approximately 10.0% of the population in Carson City is uninsured, followed by 8.9% in Lyon County. Nearly fifteen percent of the Carson City population aged 19 to 64 is uninsured. This is higher than the national percentage, but lower than statewide.

Data for the Carson Tahoe Health service area is based on aggregated data available at the ZIP Code level. For some measures, ZIP Code data is not available.

---

<sup>87</sup> U.S. Department of Health and Human Services, *Healthy People 2030. Social Determinants of Health Literature Summaries, Access to Health Services*. Link: [health.gov/healthypeople/priority-areas/social-determinants-health/literature-summaries/access-health-services](https://health.gov/healthypeople/priority-areas/social-determinants-health/literature-summaries/access-health-services)

## QUAD-COUNTY REGIONAL COMMUNITY HEALTH NEEDS ASSESSMENT

**Exhibit 133: Uninsured Population**

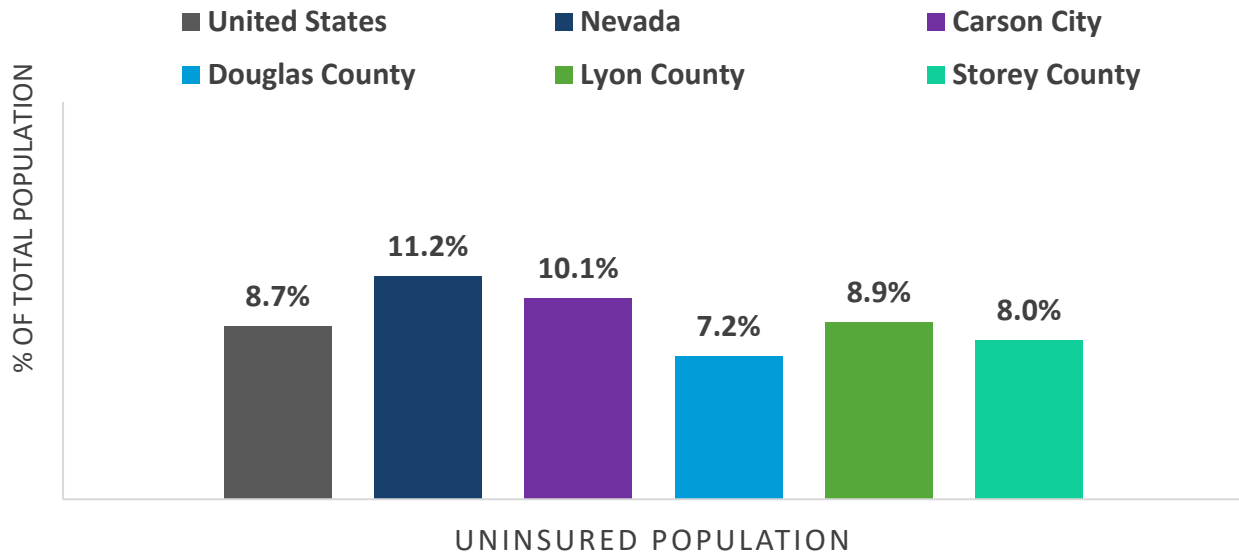

Source: U.S. Census Bureau, 2016-2020 American Community Survey Five-Year Estimates

	United States	Nevada	Carson City	Douglas County	Lyon County	Storey County
<b>Uninsured Population</b>	28,058,903	334,130	5,336	3,467	4,921	324
% of Population Uninsured	8.7%	11.2%	10.1%	7.2%	8.9%	8.0%
<b>Age</b>						
Under 19	5.2%	7.7%	7.3%	5.6%	5.4%	11.0%
19 to 64	12.3%	15.1%	14.5%	11.3%	13.3%	12.2%
65 and older	0.8%	1.3%	0.5%	0.3%	0.6%	0.0%

Source: U.S. Census Bureau, 2016-2020 American Community Survey Five-Year Estimates

The maps below indicate the population between the ages of 18 and 64 who do not have health insurance, highlighted by zip code tabulated areas. Darker shaded areas indicate higher percentages of the uninsured by county.

## QUAD-COUNTY REGIONAL COMMUNITY HEALTH NEEDS ASSESSMENT

**Exhibit 134: Estimated Percent of Uninsured Adults Aged 18-64 by County**

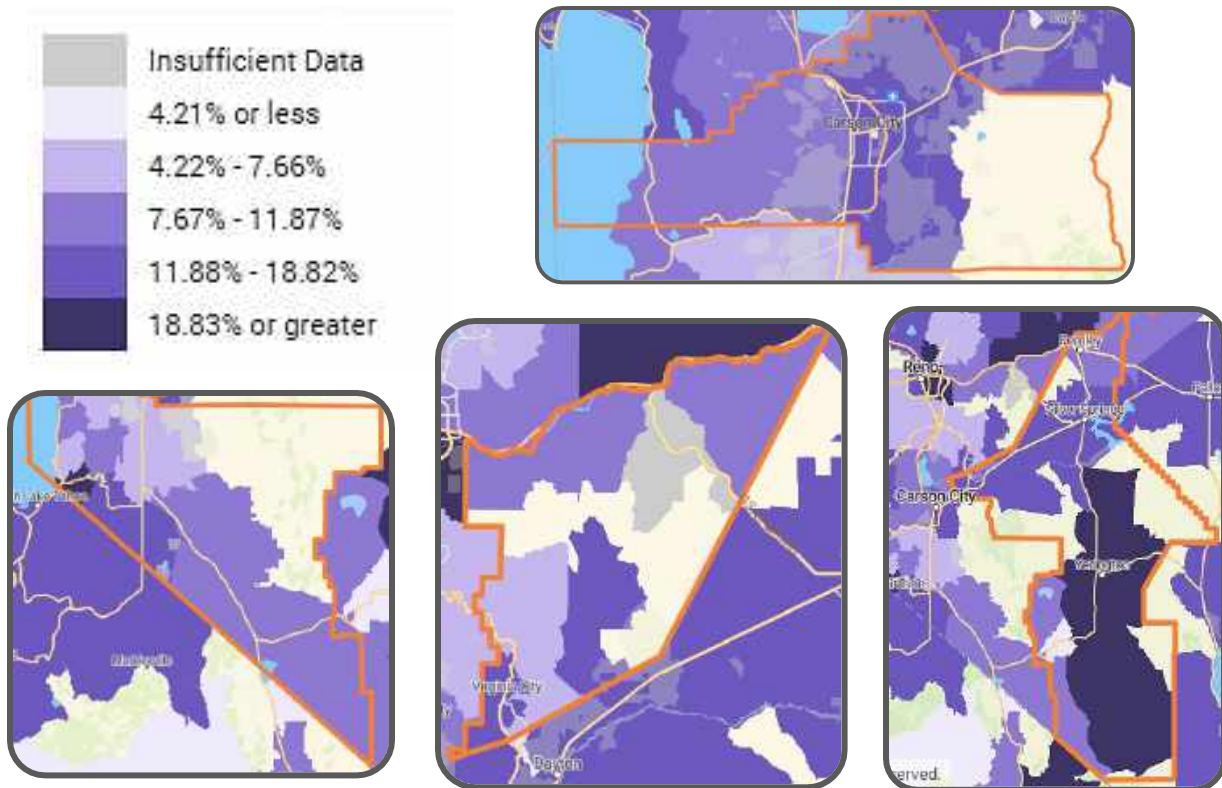

Carson City (top right), Douglas County (bottom left), Lyon County (bottom middle), Storey County (bottom right)

Source: PolicyMap. U.S. Census Bureau. 2016-2020 American Community Survey Five Year Estimates.

The uninsured population by race indicates disparities between races within the service area. Overall, American Indian or Alaskan Native and Black or African Americans are more likely to be uninsured compared to people identifying as White alone (any ethnicity). In Douglas County, nearly a quarter of the Black or African American and nearly 20.0% of American Indian or Alaskan Natives are uninsured.

QUAD-COUNTY REGIONAL COMMUNITY HEALTH NEEDS ASSESSMENT

Exhibit 135: Uninsured Population by Race

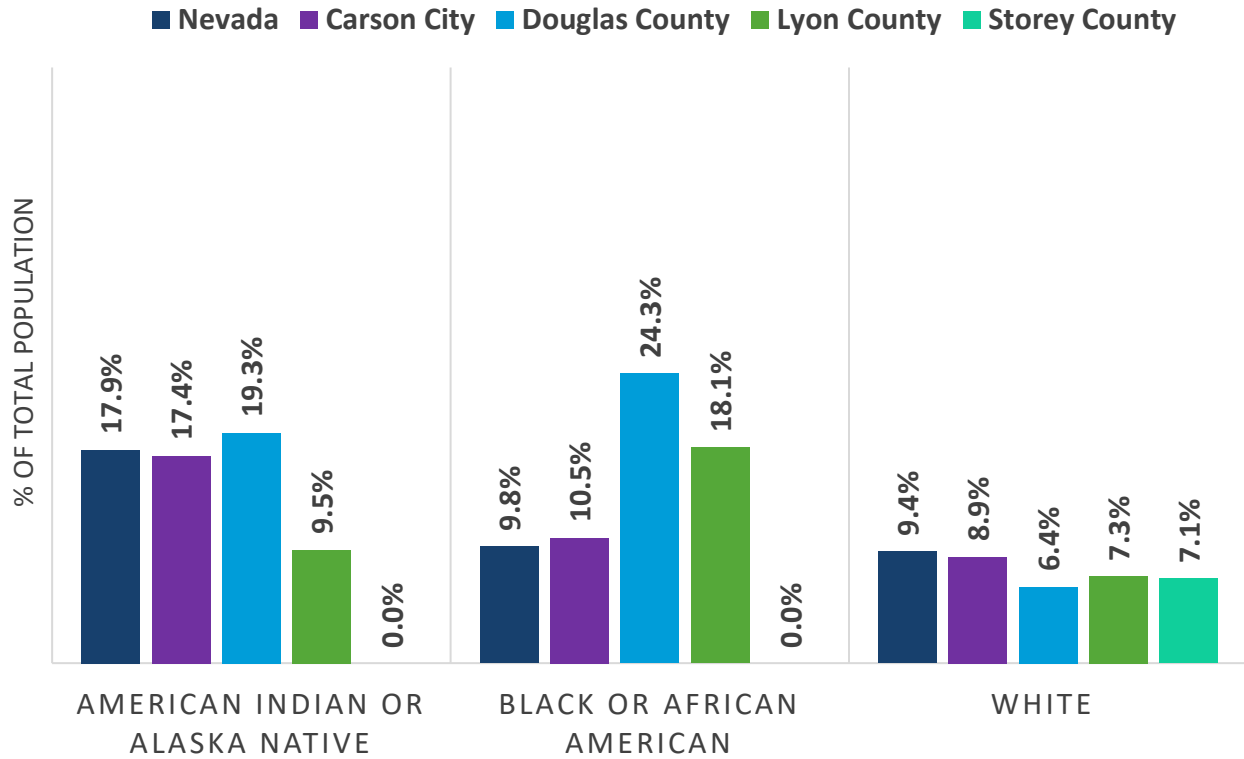

	Nevada	Carson City	Douglas County	Lyon County	Storey County
American Indian or Alaska Native	17.9%	17.4%	19.3%	9.5%	0.0%
Black or African American	9.8%	10.5%	24.3%	18.1%	0.0%
White	9.4%	8.9%	6.4%	7.3%	7.1%

Source: U.S. Census Bureau, 2016-2020 American Community Survey Five-Year Estimates

## Underinsured Population

While there is no universal definition for being underinsured, for the purposes of this Community Health Needs Assessment underinsured populations have the following traits:

### Who Are the Underinsured?

People who are underinsured have high health plan deductibles and high out-of-pocket medical expenses relative to their incomes.

Like uninsured people, individuals who are underinsured are more likely to have difficulties paying medical bills and to forgo medical care and needed treatments because of cost.

**Non-elderly adults who were insured for the entire year in 2018, 29.0% were underinsured, a six percent increase from 2014.**

*PAN Foundation*

- Individual out-of-pocket healthcare costs in the last year, not counting premiums, represent 10.0% or more of individual household income. **Note** that the threshold drops to five percent if an individual is living under 200.0% of the federal poverty level. That is less than \$53,000 for a family of four in 2021 in any state but Hawaii or Alaska.
- The deductible, or the amount required to pay before health insurance starts paying covered medical costs, is at least five percent of individual income.<sup>88</sup>

Many underinsured people are employed and have health insurance through their employers, but for many workers, the cost of these plans is very high relative to their incomes. In 2018, 28.0% of people with health insurance through their employers were underinsured. The Affordable Care Act facilitated access to health insurance for many people by allowing them to buy individual insurance or to explore Marketplace health plans, but in 2018, 42.0% of people who had Marketplace insurance reported being underinsured.

The 2020 Commonwealth Fund Biennial Health Insurance Survey found that nationwide, 21.3% of adults were underinsured. Key findings from the report also include:

- In the first half of 2020, 43.4% of adults were inadequately insured. This group is made up of people who were uninsured at the time of the survey (12.5%), were insured but had experienced a coverage gap in the past year (9.5%) or were insured continuously but had such high out-of-pocket costs or deductibles relative to their income that they were effectively underinsured (21.3%).

<sup>88</sup> Kaiser Family Foundation Healthcare Debt Survey: Feb.-Mar. 2022. Link: [kff.org/report-section/kff-health-care-debt-survey-main-findings/](https://kff.org/report-section/kff-health-care-debt-survey-main-findings/)

## QUAD-COUNTY REGIONAL COMMUNITY HEALTH NEEDS ASSESSMENT

- Hispanic and Latino adults had underinsured rates that were two times as high as their higher-income counterparts.
- One quarter of adults in employer plans were underinsured. Because there were an estimated 122 million working-age people in employer plans, compared to just 15 million in the individual market, there were far more underinsured people with employer coverage than with individual market insurance.<sup>89</sup>

In Nevada, nearly half of the population receive their health insurance coverage through an employer only, followed by Medicaid. Nationally, one quarter of adults with employer plans are considered underinsured. Given this, it can be inferred that there is a fair percentage of underinsured people in Nevada.

**Exhibit 136: Health Insurance Coverage of the Total Population**

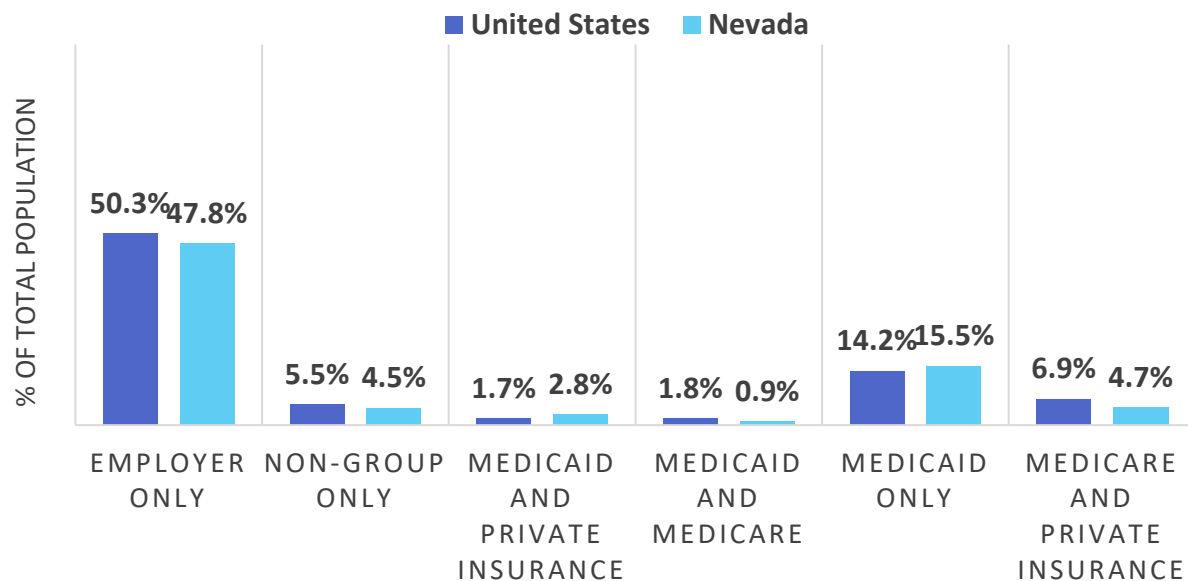

Source: Kaiser Family Foundation estimates based on the Census Bureau's March Current Population Survey (CPS: Annual Social & Economic Supplements), 2017-2021

### Data Key

**Employer Only:** Includes those covered by employer-sponsored coverage either through their own job or as a dependent in the same household.

**Non-Group Only:** Includes individuals and families who purchased or are covered as a dependent by non-group insurance.

**Medicaid and Private Insurance:** Includes those covered by Medicaid and private insurance through an employer or non-group insurance.

**Medicaid and Medicare:** Includes those covered by both Medicaid and Medicare, also known as dual eligible.

<sup>89</sup> Commonwealth Fund. U.S. Health Insurance Coverage in 2020: A Looming Crisis in Affordability, 2020. Link: [commonwealthfund.org/publications/issue-briefs/2020/aug/looming-crisis-health-coverage-2020-biennial](https://commonwealthfund.org/publications/issue-briefs/2020/aug/looming-crisis-health-coverage-2020-biennial)

Data Key

**Medicaid Only:** Includes those covered by Medicaid, Medical Assistance, Children's Health Insurance Plan (CHIP) or any kind of government-assistance plan for those with low incomes or a disability.

**Medicare and Private Insurance:** Includes those covered by Medicare and private insurance through an employer or non-group insurance.

Exhibit 137: Health Insurance Coverage of Children

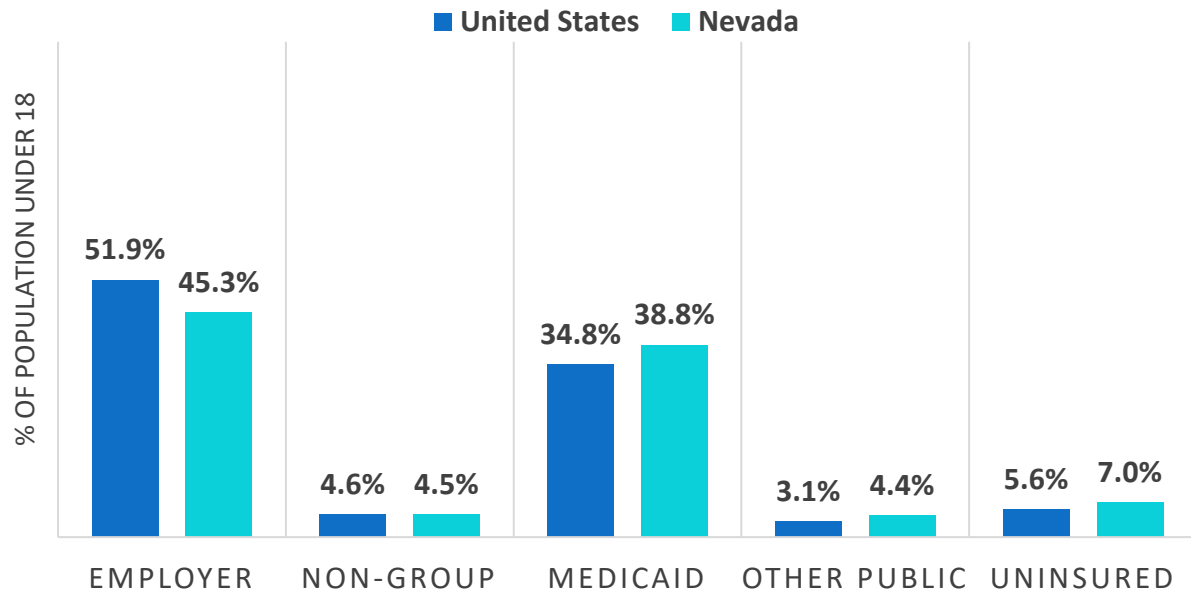

Source: Kaiser Family Foundation estimates based on the Census Bureau's March Current Population Survey (CPS: Annual Social & Economic Supplements), 2017-2021.

DATA INDICATORS

**Medicaid:** Includes those covered by Medicaid, Medical Assistance, Children's Health Insurance Plan (CHIP) or any kind of government-assistance plan for those with low incomes or a disability, as well as those who have both Medicaid and another type of coverage, such as dual eligible who are also covered by Medicare.

**Employer:** Includes those covered by employer-sponsored coverage either through their own job or as a dependent in the same household.

**Other Public:** Includes those covered under the military or Veterans Administration as well as nonelderly Medicare enrollees.

**Non-Group:** Includes individuals and families that purchased or are covered as a dependent by non-group insurance.



## Healthcare Facility Profile

Within the Quad-County Region, there are very few Federally Qualified Health Centers (FQHCs), also referred to as Community Health Centers. There is a cluster of FQHC’s just north of the service area in Reno, however, accessibility challenges are common given there are little to no public transportation services.

**Exhibit 138: Hospitals Within the Quad-County Region**



Health Center	Town	County
South Lyon Medical Center	Yerington	Lyon County
Carson Valley Medical Center	Gardnerville	Douglas County
Carson Tahoe Continuing Care Hospital	Carson City	Carson City
Carson Tahoe Regional Medical Center	Carson City	Carson City

Source: PolicyMap (Hospitals) Health Resources & Services Administration, 2022

## QUAD-COUNTY REGIONAL COMMUNITY HEALTH NEEDS ASSESSMENT

The Health Resources and Services Administration identified four federally funded health centers that provide health services. Douglas and Lyon County have no reported facilities.

### Exhibit 139: Health Center by Program Type

County	Site Name	Health Center Type	Location Type
Carson City	Nevada Health Centers Carson City School Based	Service Delivery Site	Permanent
Carson City	Miles For Smiles	Service Delivery Site	Mobile Van
Carson City	Sierra Nevada Health Center & NVHC Administrative Offices	Administrative/Service Delivery Site	Permanent
Storey County	Nevada Health Centers at Virginia City	Service Delivery Site	Permanent

Source: Health Resources & Services Administration, 2022

Carson City has the highest community hospital bed and long-term bed capacity in the Quad-County Region, approximately 4.4 beds per 1,000 population. Fewer community hospital or long-term beds exist in Douglas, Lyon, and Storey counties.

### Exhibit 140: Community Hospital Beds<sup>90</sup>

Nevada		Carson City		Douglas County		Lyon County		Storey County	
Rate	#	Rate	#	Rate	#	Rate	#	Rate	#
2.1	5,320	4.4	220	0.5	23	0.2	14	0.0	0

Source: University of Nevada, Reno School of Medicine. Office of Statewide Initiatives & Bureau of Healthcare Quality & Compliance, Nevada Compare Care & Nevada Rural Hospital Partners, 2020

### Exhibit 141: Rate of Long-Term Beds

Nevada	Carson City	Douglas County	Lyon County	Storey County
1.8	7.6	1.2	2.6	0.0

<sup>90</sup> Rates, 2018 Data. Number of beds, 2020 Data.

### Healthcare Workforce

The COVID-19 pandemic has taken a heavy toll on healthcare providers across all disciplines, as those who have remained on the front lines of the pandemic have reported suffering from stress, trauma, burnout, and increased behavioral health challenges. In 2021, a nation-wide survey found that nearly 30.0% of healthcare workers are considering leaving their profession altogether, and nearly 60.0% reported impacts to their mental health stemming from their work during the COVID-19 pandemic.<sup>91</sup>

Nevada is not spared from a national shortage of providers, as healthcare work force projections share that America will face a shortage of up to 124,000 physicians by 2033 and will need to hire at least 200,000 nurses per year to meet increased demand and to replace retiring nurses.<sup>92</sup>

The following data highlights the healthcare workforce at various licensure levels. It is important to understand specific differences between the MD workforce and DO workforce.

### MDs & DOs

**Doctor of Osteopathic Medicine (DO) and Doctor of Medicine (MD) are two types of accredited doctor that can practice medical care in the United States.**

The main difference between DOs and MDs comes down to the philosophy of care. DOs practice an osteopathic approach to care, while MDs practice an allopathic approach to care. An MD is a traditional medicine degree, while a DO takes a holistic, mind-body-spirit approach to care. In the U.S., the same licensing boards give licenses to both types of doctors, and they must meet the same standards for practicing medicine.

*Medical News Today*

<sup>91</sup> Kaiser Family Foundation & The Washington Post. *Frontline Healthcare Workers Survey, 2021*. Link: [kff.org/report-section/kff-the-washington-post-frontline-health-care-workers-survey-toll-of-the-pandemic/](https://kff.org/report-section/kff-the-washington-post-frontline-health-care-workers-survey-toll-of-the-pandemic/)

<sup>92</sup> American Hospital Association. *Fact Sheet: Strengthening The Healthcare Workforce, May 2021*. Link: [aha.org/fact-sheets/2021-05-26-fact-sheet-strengthening-health-care-workforce](https://aha.org/fact-sheets/2021-05-26-fact-sheet-strengthening-health-care-workforce)

### A Key Note About the Data

To provide the most fair and accurate overview of each service area county's healthcare workforce, Crescendo Consulting Group met with key leadership at the Nevada Health Workforce Research Center to determine limitations in the data presented in the University of Nevada, Reno School of Medicine Office of Statewide Initiatives Instant Atlas.

Although workforce data has been confirmed to reflect the most up-to-date numbers and rates available, the following limitations are critical to understanding the "full picture" of the healthcare workforce in each of the Quad-County Regions.

#### Data Limitations:

- Data on licensed active healthcare provider is collected **by billing address only**.
- Current collection methods **do not** collect data on race/ethnicity, sub-specialty (if applicable), or part-time or full-time status of healthcare providers.
- Numbers and/or rates may reflect providers that may work in one geographical area, **but travel to other counties periodically**.

*For example, if a dentist from Carson City provides services to Storey County every Wednesday, the current data collecting methodology may count that as a standing provider in Storey County.*

### Improving Data Collection Statewide

In May of 2021, the Senate Committee on Health and Human Services (on Behalf of the Legislative Committee on Healthcare) sponsored bill, **SB379**, passed. Senate Bill 379 requires the director of the Department of Health and Human Services (DHHS),

*"to establish and maintain a database comprised of information collected from certain applicants for the renewal of a license, certificate, or registration as a healthcare provider. The information must contain certain demographic information and certain information about the applicant's practice."*

*Nevada Legislature*

**Primary Care Providers**

Overall, higher rates of healthcare providers in Carson City are attributed to the concentration of Carson Tahoe Healthcare Network service locations within the area. Primary care providers offer a usual source of care, early detection, and treatment of disease, chronic disease management, and preventive care. Patients with a usual source of care are more likely to receive recommended preventive services such as flu shots, blood pressure screenings, and cancer screenings.<sup>93</sup>

**About the Data**  
Rates of healthcare providers are per 100,000 population unless specified.

Carson City has the highest rate of primary care physicians, both MDs and Dos, within the service area, followed by Douglas County.

**Exhibit 142: Rate of Active Licensed Primary Care Physicians per 100,000 Population**

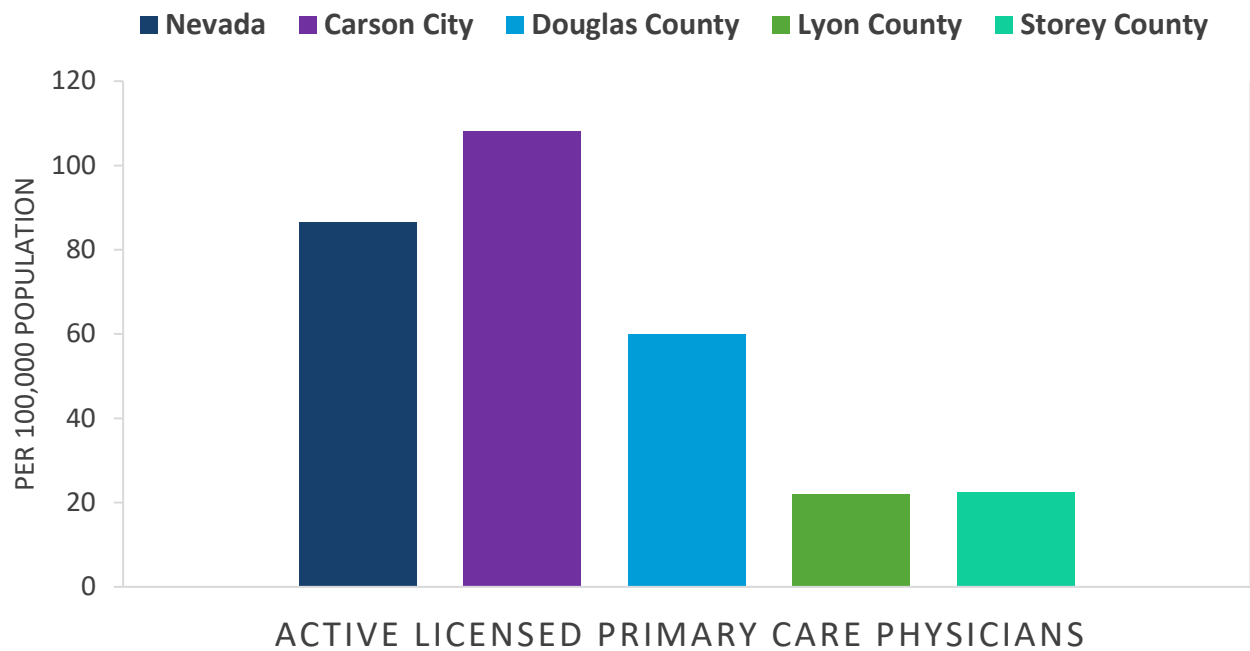

Nevada		Carson City		Douglas County		Lyon County		Storey County	
Rate	#	Rate	#	Rate	#	Rate	#	Rate	#
86.4	2,782	108.0	62	60.0	33	22.0	13	22.4	1

Source: University of Nevada, Reno School of Medicine’s Office of Statewide Initiatives, Nevada Instant Atlas. Nevada State Board of Medical Examiners, 2022

<sup>93</sup> U.S. Department of Health and Human Services, Healthy People 2030. Social Determinants of Health Literature Summaries, Access to Health Services. Link: [health.gov/healthypeople/priority-areas/social-determinants-health/literature-summaries/access-health-services](https://health.gov/healthypeople/priority-areas/social-determinants-health/literature-summaries/access-health-services)

## QUAD-COUNTY REGIONAL COMMUNITY HEALTH NEEDS ASSESSMENT

Within the Quad-County Region, there is a higher concentration in Carson City of general practice and family practice providers.

**Exhibit 143: General Practice Providers<sup>94</sup>**

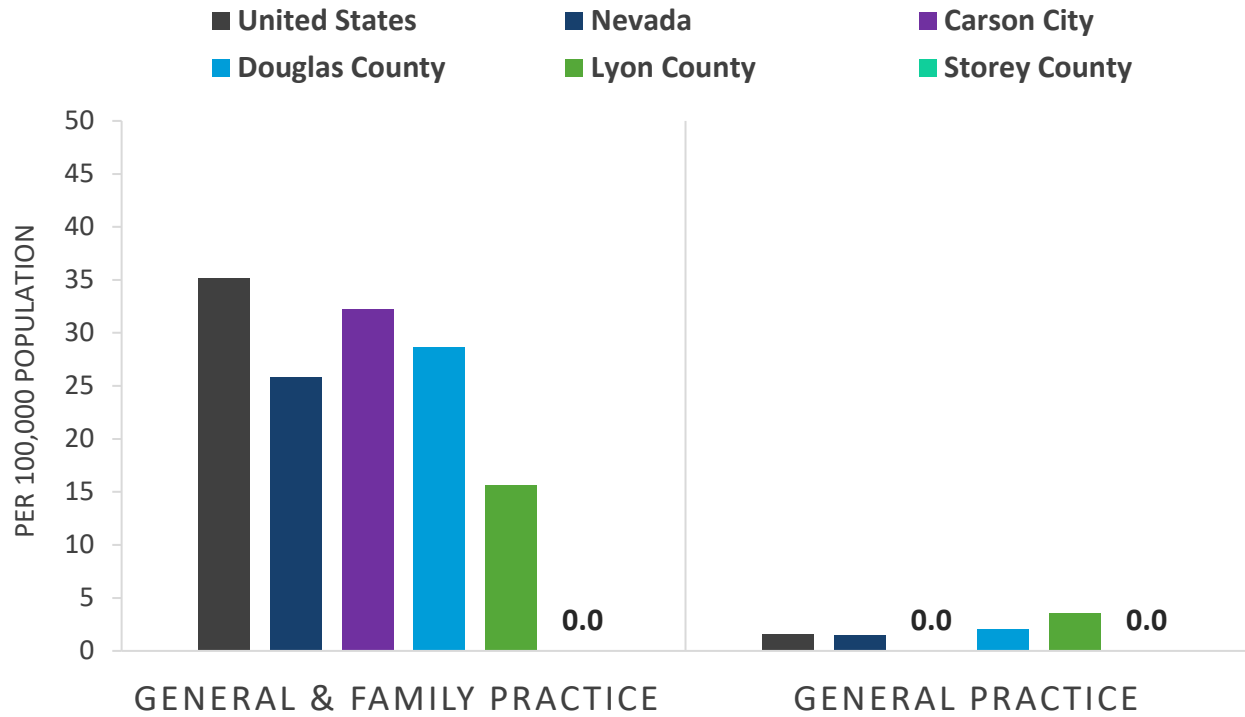

	United States		Nevada		Carson City		Douglas County		Lyon County		Storey County	
	Rate	#	Rate	#	Rate	#	Rate	#	Rate	#	Rate	#
General and Family Practice	35.1	ND	25.8	826	32.2	18	28.6	14	15.6	9	0.0	0
General Practice	1.6	ND	1.5	45	0.0	0	2.0	1	3.5	2	0.0	0

Source: University of Nevada, Reno School of Medicine's Office of Statewide Initiatives, Nevada Instant Atlas. Health Resources and Services Administration. Find shortage Areas: HPSA by State and County, 2019

<sup>94</sup> MD & DO.

## QUAD-COUNTY REGIONAL COMMUNITY HEALTH NEEDS ASSESSMENT

Similarly to general practice providers, Carson City has the highest rates of family medicine and pediatric general practice providers, both MDs and Dos, within the service area.

**Exhibit 144: Family & Pediatric Providers**

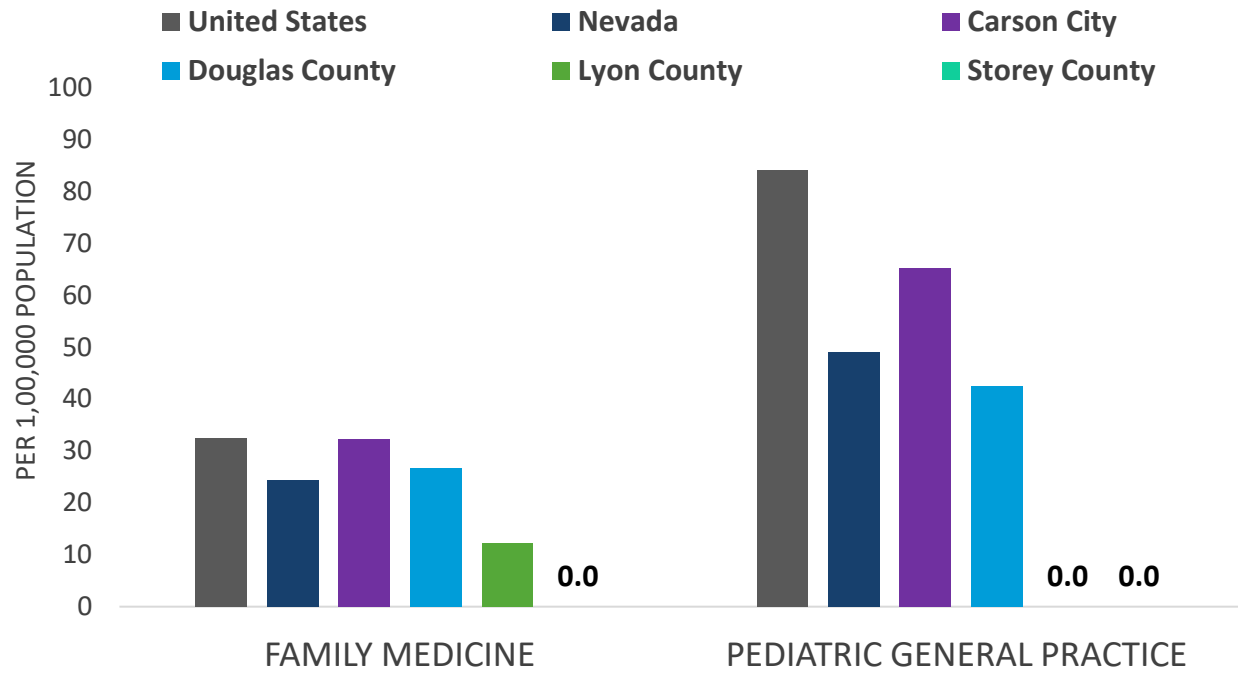

	United States		Nevada		Carson City		Douglas County		Lyon County		Storey County	
	Rate	#	Rate	#	Rate	#	Rate	#	Rate	#	Rate	#
Family Medicine	32.4	ND	24.3	749	32.2	18	26.6	13	12.2	7	0.0	0
Pediatric General Practice	84.1	ND	49.1	319	65.3	9	42.5	4	0.0	0	0.0	0

Source: University of Nevada, Reno School of Medicine's Office of Statewide Initiatives, Nevada Instant Atlas. Health Resources and Services Administration. Find shortage Areas: HPSA by State and County,2020

## QUAD-COUNTY REGIONAL COMMUNITY HEALTH NEEDS ASSESSMENT

### Specialty Care Providers

The term “specialty healthcare service” means a healthcare service that requires the services of a healthcare professional with specialized knowledge or experience. Specialty healthcare service includes any service relating to dialysis, surgery, mammography, or any other specialty healthcare service.<sup>95</sup>

Communities do not have equal access to specialty healthcare providers per county.

**Exhibit 145: Medical Specialists**

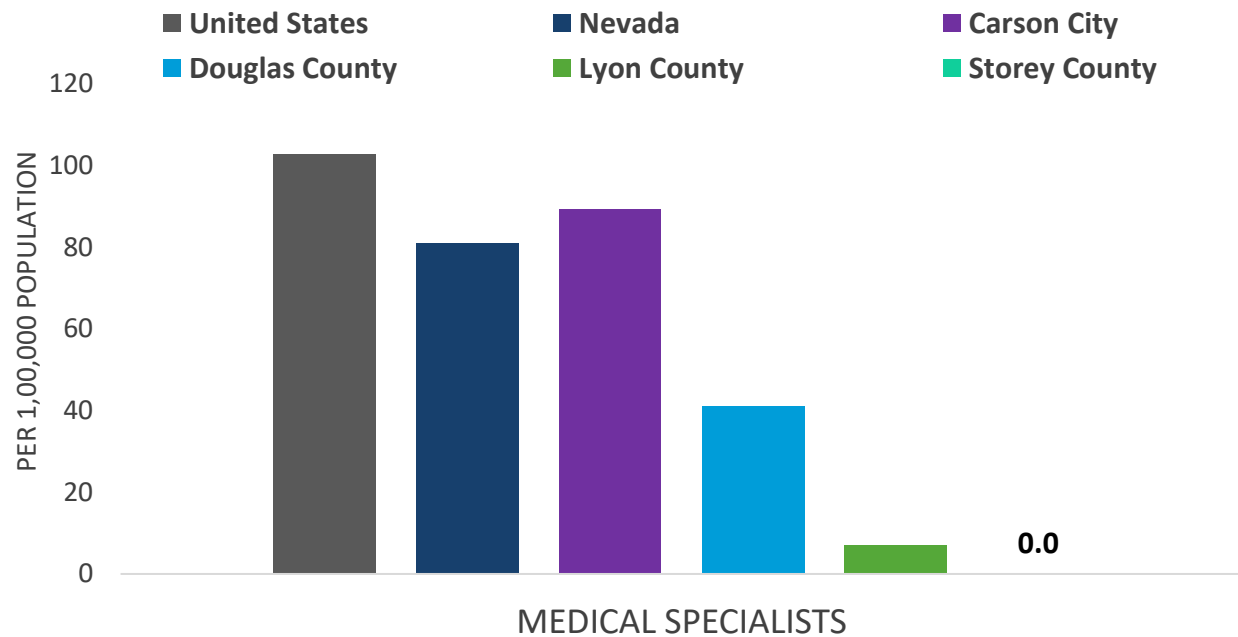

United States		Nevada		Carson City		Douglas County		Lyon County		Storey County	
Rate	#	Rate	#	Rate	#	Rate	#	Rate	#	Rate	#
102.7	ND	80.8	2,008	89.4	41	40.9	20	7.0	3	0.0	0

Source: University of Nevada, Reno School of Medicine’s Office of Statewide Initiatives, Nevada Instant Atlas. Health Resources and Services Administration. Find shortage Areas: HPSA by State and County, 2019

<sup>95</sup> Cornell Law School.



## QUAD-COUNTY REGIONAL COMMUNITY HEALTH NEEDS ASSESSMENT

Rates indicate that Carson City is the only area within the Quad-County Region with cardiovascular disease and gastroenterology specialists (7.2 cardiovascular disease providers per 100,000 population, 3.6 gastroenterology providers per 100,000 population). Chiropractors are also more common than any of the select specialty care providers. Douglas County has an additional three dermatologists in addition to three in Carson City.

**Exhibit 146: Specialty Care Providers<sup>96</sup>**

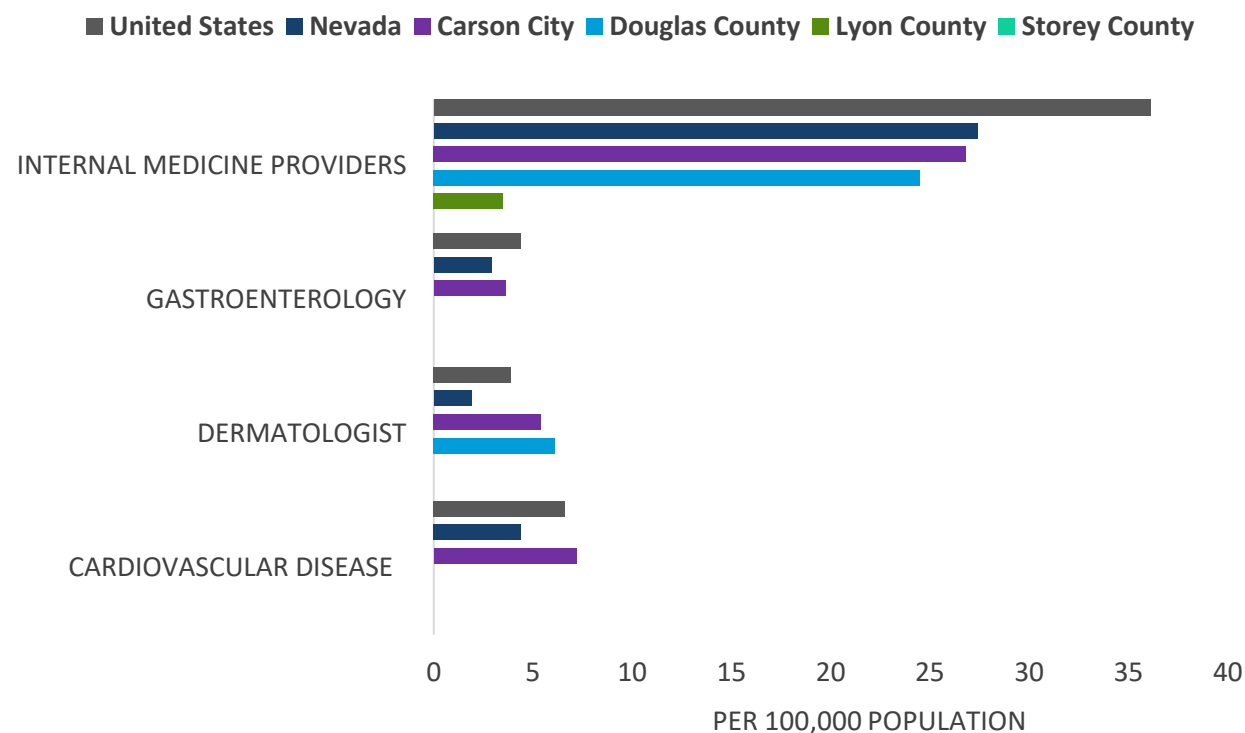

	United States		Nevada		Carson City		Douglas County		Lyon County		Storey County	
	Rate	#	Rate	#	Rate	#	Rate	#	Rate	#	Rate	#
Cardiovascular Disease	6.6	ND	4.4	135	7.2	4	0.0	0	0.0	0	0.0	0
Dermatologist	3.9	ND	1.9	58	5.4	3	6.1	3	0.0	0	0.0	0
Gastroenterology	4.4	ND	2.9	90	3.6	2	0.0	0	0.0	0	0.0	0
Internal Medicine Providers	36.1	ND	27.4	927	26.8	17	24.5	12	3.5	2	0.0	0
Chiropractors <sup>97</sup>	ND	ND	21.3	689	34.4	20	25.9	13	11.2	7	0.0	0

Source: University of Nevada, Reno School of Medicine's Office of Statewide Initiatives, Nevada Instant Atlas. Health Resources and Services Administration. Find shortage Areas: HPSA by State and County, 2019

<sup>96</sup> MD only.

<sup>97</sup> 2022 Data.

## QUAD-COUNTY REGIONAL COMMUNITY HEALTH NEEDS ASSESSMENT

The biggest difference between a pharmacist and a pharmacy technician is the level of education achieved by each, as in many states a pharmacy technician is not required to have any formal training beyond high school. In Nevada, most are required to get a state license and/or be certified nationally. Pharmacists are required to hold a doctorate degree in pharmacology.<sup>98</sup> Storey County has no pharmacists within the area, and only one Pharmaceutical Technician.

### Exhibit 147: Pharmacists

	United States		Nevada		Carson City		Douglas County		Lyon County		Storey County	
	Rate	#	Rate	#	Rate	#	Rate	#	Rate	#	Rate	#
Pharmacists	98.0	ND	82.7	2,613	51.4	29	68.3	34	29.5	17	0.0	0
Pharmaceutical Technicians	128.7	ND	148.1	4,681	127.7	72	92.3	46	137.1	79	22.9	1

Source: University of Nevada, Reno School of Medicine's Office of Statewide Initiatives, Nevada Instant Atlas. Nevada State Board of Medical Examiners, 2020

Lyon County has the highest rate of emergency medical responders and emergency medical technicians within the service area. See exhibit below to learn the difference.

### Exhibit 148: Emergency Medical Providers

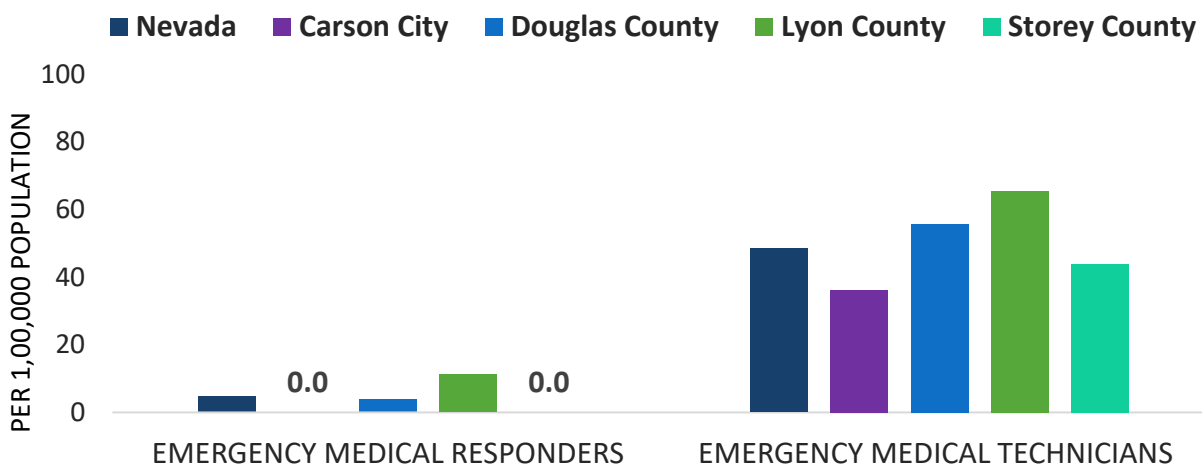

	Nevada	Carson City	Douglas County	Lyon County	Storey County
Emergency Medical Responders	4.9	0.0	4.0	11.2	0.0
Emergency Medical Technicians	48.5	36.2	55.8	65.5	44.0

Source: University of Nevada, Reno School of Medicine's Office of Statewide Initiatives, Nevada Instant Atlas. Nevada State Board of Medical Examiners, 2022

<sup>98</sup> ePharmacyTechnicians, The Difference Between a Pharmacist and a Pharmacy Technician.

Exhibit 149: Emergency Medical Responders Versus Emergency Medical Technicians

**Emergency Medical Responders**

- **Emergency Medical Responders (EMRs) provide immediate lifesaving care to critical patients who access the emergency medical services system.**
- EMRs have the knowledge and skills necessary to provide immediate lifesaving interventions while awaiting additional EMS resources to arrive.
- EMRs also provide assistance to higher-level personnel at the scene of emergencies and during transport.
- Under medical oversight, Emergency Medical Responders perform basic interventions with minimal equipment.

**Emergency Medical Technicians**

- **Emergency Medical Technicians (EMTs) provide out of hospital emergency medical care and transportation for critical and emergent patients who access the emergency medical services (EMS) system.**
- EMTs have the basic knowledge and skills necessary to stabilize and safely transport patients ranging from non-emergency and routine medical transports to life threatening emergencies.
- EMTs function as part of a comprehensive EMS response system, under medical oversight. Emergency Medical Technicians perform interventions with the basic equipment typically found on an ambulance.
- EMTs are a critical link between the scene of an emergency and the healthcare system.

Source: National Registry of Emergency Medical Technicians

### About the Data

The ratio of primary care physicians and dentists represents the number of individuals served by one provider if the population was equally distributed across providers within a country, state, or county.

For example, if a county has a population of 50,000 and has 20 primary care physicians, the ratio would be 2,500:1. The value on the right side of the ratio is always 1 or 0; 1 indicates that there is at least one primary care physician in the county, and zero indicates there are no primary care physicians in the county.

Regular preventative dental care is essential for good overall health, but research suggests people are unable to afford dental care more than other types of healthcare. Many people live in communities where they do not have access to fluoridated water and school sealant programs, healthy foods, and public transportation to get to dental appointments.<sup>99</sup>

The number of dentists in the Quad-County Region is lower than state and national rates.

#### Exhibit 150: Oral Healthcare Providers

	United States		Nevada		Carson City		Douglas County		Lyon County		Storey County	
	Rate	#	Rate	#	Rate	#	Rate	#	Rate	#	Rate	#
Dentists	46.2	ND	55.9	1,766	79.8	45	62.2	31	17.3	10	0.0	0
Registered Dental Hygienists	69.0	ND	46.8	1,479	47.9	27	76.3	38	38.2	22	68.6	3

Source: University of Nevada, Reno School of Medicine’s Office of Statewide Initiatives, Nevada Instant Atlas. Nevada State Board of Dental Examiners, 2022

#### Exhibit 151: Eye Care Providers

	United States		Nevada		Carson City		Douglas County		Lyon County		Storey County	
	Rate	#	Rate	#	Rate	#	Rate	#	Rate	#	Rate	#
Optometrists	ND	ND	14.2	461	31.0	18	17.9	9	4.8	3	0.0	0

Source: University of Nevada, Reno School of Medicine’s Office of Statewide Initiatives, Nevada Instant Atlas. Nevada State Board of Optometry, 2022

<sup>99</sup> Center for Chronic Disease Prevention & Health Promotion. Division Of Oral Health, Disparities In Oral Health. Link: [cdc.gov/oralhealth/oral\\_health\\_disparities/index.htm](https://cdc.gov/oralhealth/oral_health_disparities/index.htm)

## QUAD-COUNTY REGIONAL COMMUNITY HEALTH NEEDS ASSESSMENT

In Nevada there are approximately 1,710 residents per primary care physicians overall. Carson City presents a lower ratio of 1,330 residents per primary care physician.

Lyon County has higher healthcare provider and dentist ratios than state or national ratios. Douglas County has higher healthcare provider ratios than state and national levels, but lower dentist ratios than the statewide ratio.

### Exhibit 152: Healthcare Provider Ratio<sup>100</sup>

	United States	Nevada	Carson City	Douglas County	Lyon County	Storey County
Primary Care Providers	1,010:1	1,710:1	1,330:1	1,810:1	5,230:1	ND
Dentists	1,210:1	1,600:1	1,000:1	1,360:1	4,860:1	ND

Source: County Health Rankings & Roadmaps, 2019

<sup>100</sup> Primary Care Providers, 2019 data. Dentists, 2020 data.

## Health Status, Chronic Disease, & Outcomes

Health Status, Chronic Disease, & Outcomes Mortality rates measure the frequency of occurrence of death in a defined population during a specified interval.<sup>101</sup>

### Leading Causes of Death & Mortality Rates

Since 2016, overall mortality rates have increased in all service area counties and statewide. The mortality rate in Carson City increased the most within the service area (+159.1).

Exhibit 153: Trend of Mortality Rates

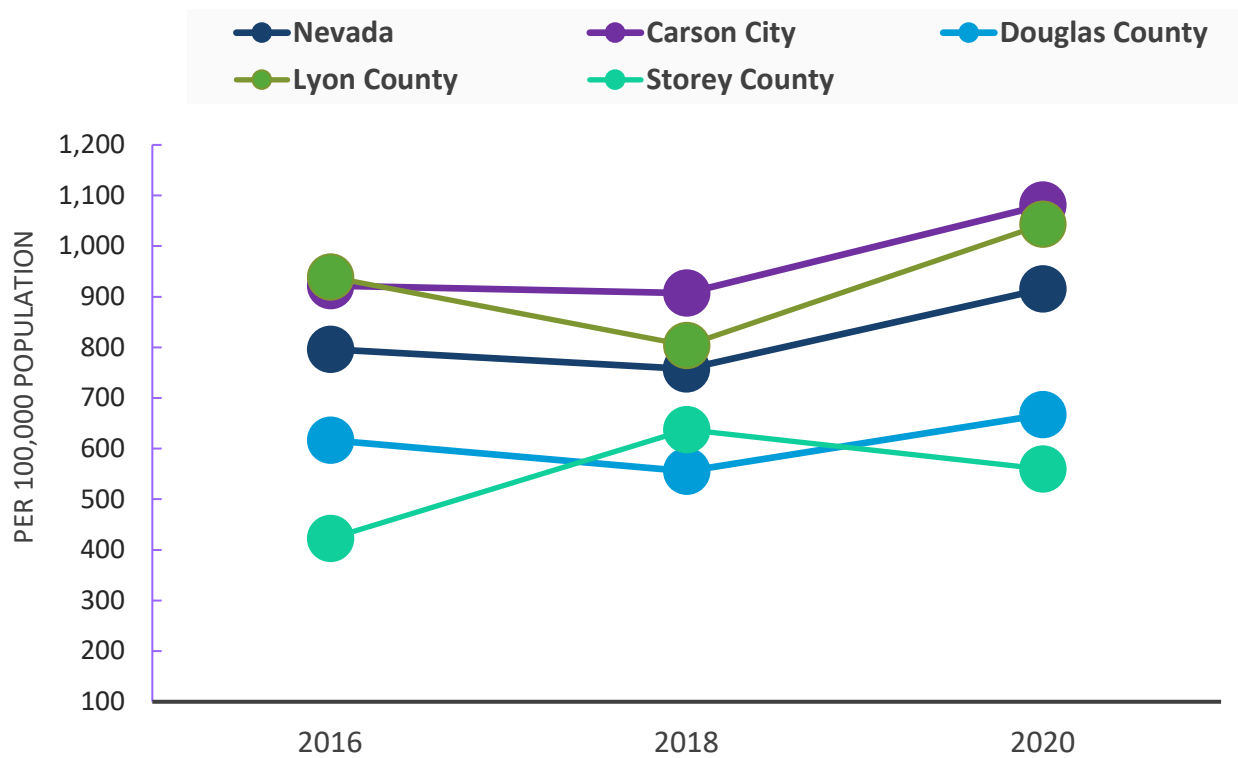

	United States	Nevada	Carson City	Douglas County	Lyon County	Storey County
2020	ND	915.3	1,081.0	667.2	1,043.0	559.8
2018	731.9	757.5	907.2	555.4	804.0	637.6
2016	728.8	796.3	921.9	616.3	938.8	422.5

Source: University of Nevada, Reno School of Medicine’s Office of Statewide Initiatives, Nevada Instant Atlas. Nevada Office of Health Statistics & Surveillance

<sup>101</sup> Deputy Director for Public Health Science & Surveillance. Center for Surveillance, Epidemiology & Laboratory Services, Division Of Scientific Education & Professional Development. Link: [cdc.gov/csels/dsepd/ss1978/lesson3/section3.html](https://cdc.gov/csels/dsepd/ss1978/lesson3/section3.html)

**About the Data**

Crude death rates equal the total number of deaths between 2018 & 2020, divided by the at-risk population for that category and multiplied by 100,000.

While crude mortality rates provide a helpful indicator of the general health status of a geographic area or population, death rates are not appropriate for comparison of different populations or areas with large differences in age distributions.

The following table indicates the 2018-2020 average crude rates of the leading causes of death.

**Exhibit 154: Leading Causes of Death<sup>102</sup>**

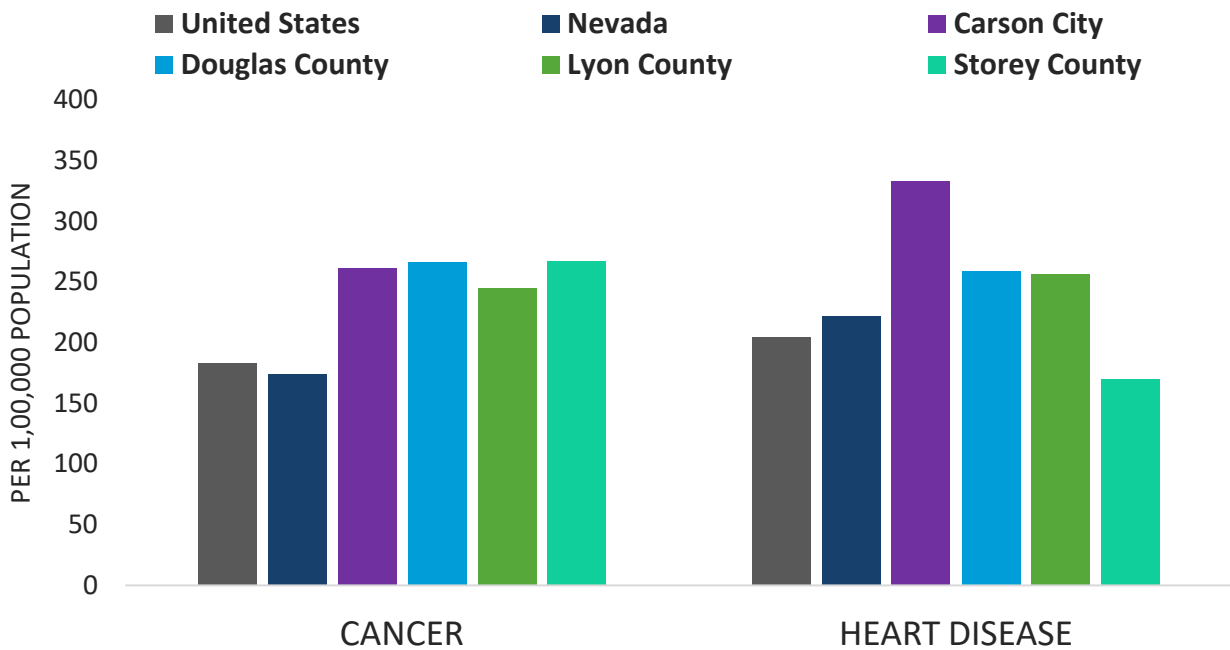

	United States	Nevada	Carson City	Douglas County	Lyon County	Storey County
Alzheimer’s Disease	38.4	25.1	31.7	20.5	32.0	ND
Cancer	182.9	173.8	261.7	266.3	244.7	267.0
Heart Disease	204.2	222.0	332.8	258.8	256.4	169.9
Influenza/Pneumonia	16.5	16.0	16.1	19.1	21.0	ND
Stroke	46.5	42.3	130.9	79.2	51.3	ND
Unintentional Injury	54.9	51.3	57.4	58.0	72.8	ND

Source: Centers for Disease Control & Prevention (CDC) WONDER Online Query System, 2018-2020

<sup>102</sup> Crude Rates.

### Fatal Unintentional Injuries

In 2020, the leading cause of fatal unintentional injuries state was drug poisonings, over half of all deaths, followed by motor vehicle traffic accidents, and unintentional fatal falls.

Exhibit 155: Causes of Unintentional Injury-Related Deaths in Nevada

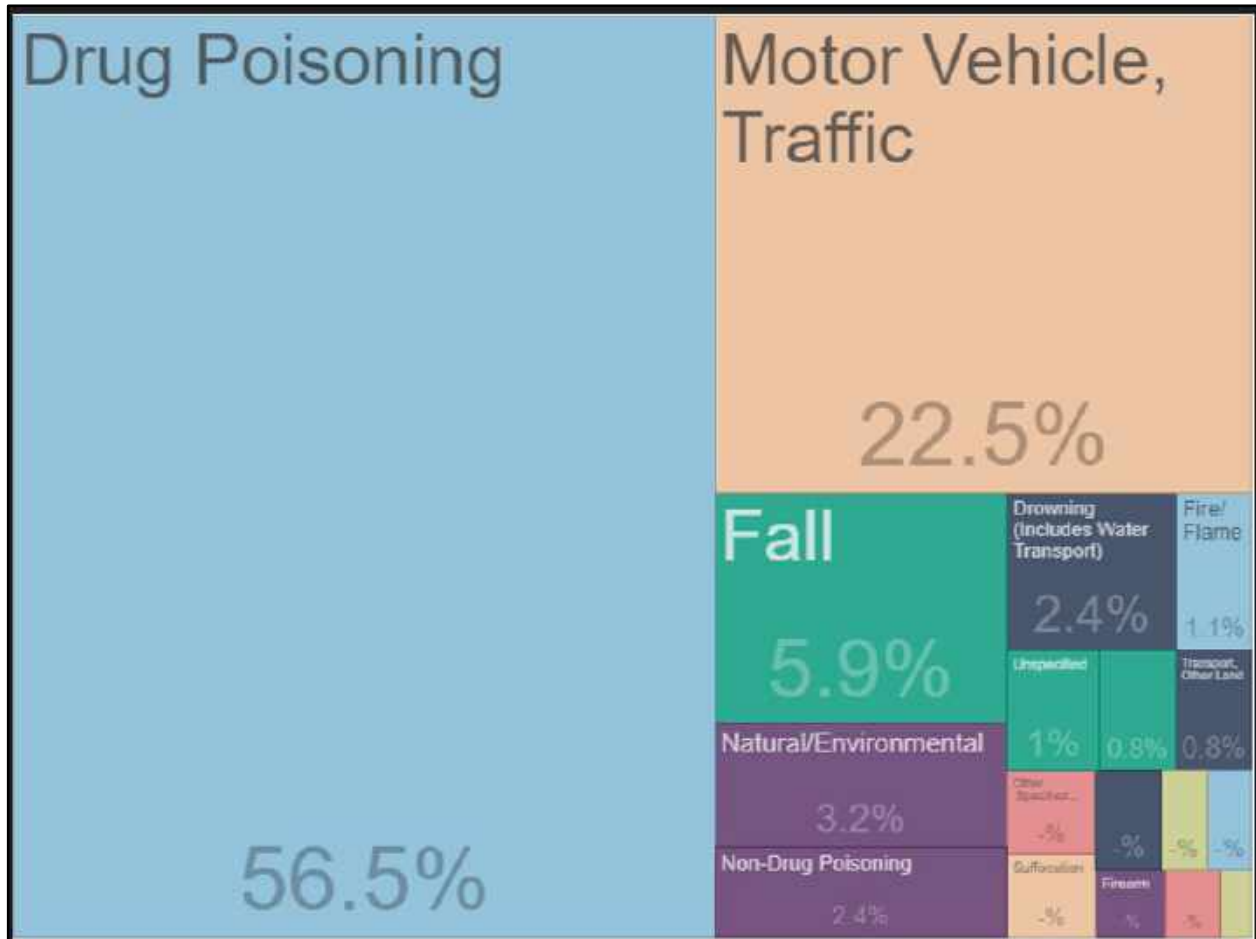

Source: Centers for Disease Control and Prevention, National Center for Injury Prevention and Control. Fatal Injury Prevention & Violence Data, 2020

The age-adjusted mortality rate of individuals between the ages of five to 65 is highest in Lyon County (58.8 deaths per 100,000 population). The injury mortality rate per 100,000 is highest in Carson City and Lyon County.

**About the Data**

Rates measure the number of events in a given time period divided by the average number of people at risk during that period. Rates help us compare data across counties with different population sizes.



## QUAD-COUNTY REGIONAL COMMUNITY HEALTH NEEDS ASSESSMENT

### Exhibit 156: Unintentional Injury-related Mortality Rate

AGES FIVE TO 64	United States	Nevada	Carson City	Douglas County	Lyon County	Storey County
Per 100,000 Population	53.4	49.9	55.8	46.6	58.8	57.2

Source: Centers for Disease Control and Prevention, National Center for Injury Prevention and Control. Fatal Injury Prevention & Violence Data, 2020

### Exhibit 157: Unintentional Injury-related Mortality Rate of Older Adults

AGES 65 AND OLDER	United States	Nevada	Carson City	Douglas County	Lyon County	Storey County
Per 100,000 Population	132.6	134.6	184.5	183.1	182.0	192.0

Source: Centers for Disease Control and Prevention, National Center for Injury Prevention and Control. Fatal Injury Prevention & Violence Data, 2020

### Exhibit 158: Fall-related Injury Mortality Rate<sup>103</sup>

AGES 65 AND OLDER	Nevada	Carson City	Douglas County	Lyon County	Storey County
Per 100,000 Population	111.70	169.0**	109.7**	203.3	*

Source: Centers for Disease Control and Prevention, National Center for Injury Prevention and Control. Fatal Injury Prevention & Violence Data, 2020

<sup>103</sup> \*\* indicates Unstable values, \* indicates Suppressed values

## Chronic Disease

Chronic diseases are defined broadly as conditions that last one year or more and require ongoing medical attention or limit activities of daily living or both.<sup>104</sup> Prevalence rates indicate the proportion of a population who have a specific characteristic in a given time period. For this data, prevalence rates indicate the proportion of a population who have ever been told they have a chronic disease in their lifetime. State-level data is available through 2021 and is reported here to indicate trends that may be experienced in the Quad-County Region and CTH PSA for the 2019-2021 period.

**Exhibit 159: Trends in Age-Adjusted Chronic Disease Prevalence in Nevada, 2019-2021**

	2019	2020	2021	Change, 2019 2021
Asthma	9.3%	9.2%	9.1%	-2.2%
COPD	7.3%	6.5%	ND	-
Diabetes	9.9%	9.9%	10.2%	+3.0%
Heart Disease	4.2%	3.7%	3.1%	-26.2%
High Blood Pressure	30.4%	ND	29.9%	-1.6%
Kidney Disease	2.7%	3.0%	3.3%	+22.2%
Stroke	2.8%	ND	ND	-
Obesity	30.4%	28.1%	31.5%	+3.6%

Source: National Center for Chronic Disease Prevention and Health Promotion, Division of Population Health. Behavioral Risk Factor Surveillance System, 2019-2021

**The most recent available County-level data, reported in the following tables, is from 2019.**

Within the service area, high blood pressure, or hypertension, and obesity are the most common chronic diseases in adults. Each of the service area counties have higher percentages of adults with heart disease. The largest percentages of obesity and high blood pressure were observed in Lyon County (36.2% and 29.5%, respectively). Between one-quarter and one-third of the population across the Quad-County Region has high blood pressure, and slightly greater proportions report being obese.

<sup>104</sup> National Center for Chronic Disease Prevention & Health Promotion. Link: [cdc.gov/chronicdisease/about/index.htm#:~:text=Chronic%20diseases%20are%20defined%20broadly,disability%20in%20the%20United%20States](https://www.cdc.gov/chronicdisease/about/index.htm#:~:text=Chronic%20diseases%20are%20defined%20broadly,disability%20in%20the%20United%20States)

## QUAD-COUNTY REGIONAL COMMUNITY HEALTH NEEDS ASSESSMENT

**Exhibit 160: Chronic Disease Prevalence**

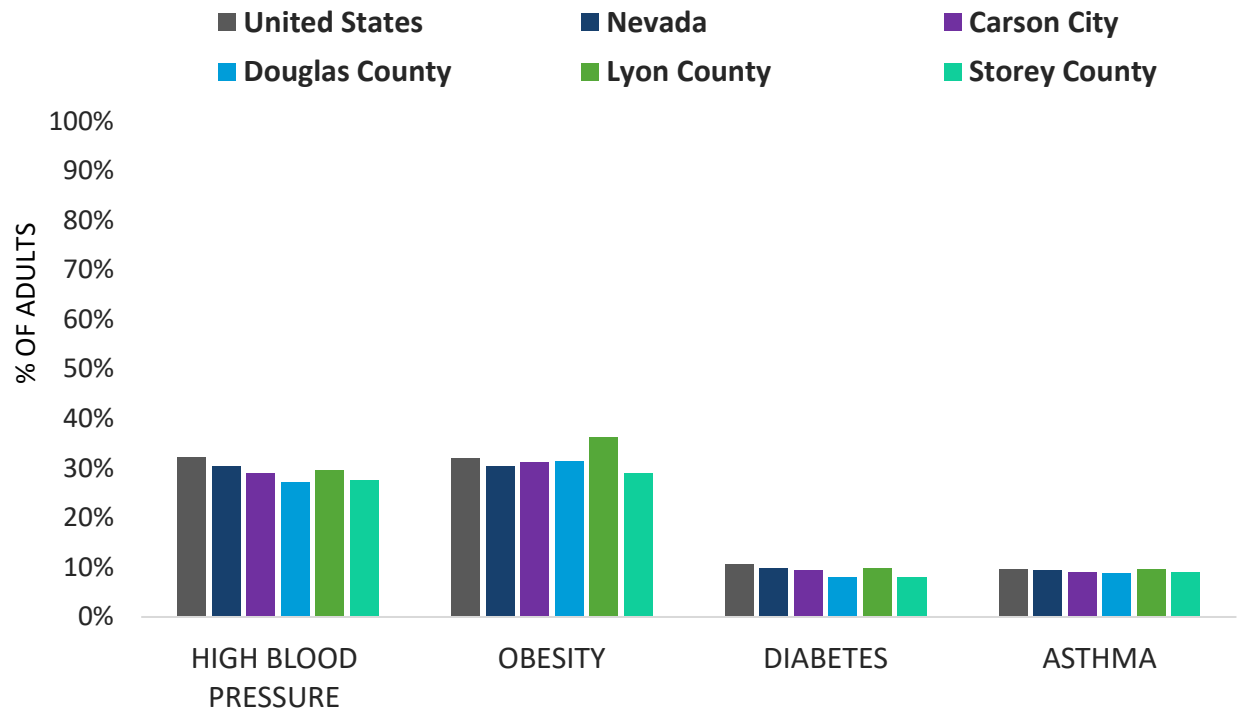

	United States <sup>105</sup>	Nevada	Carson City	Douglas County	Lyon County	Storey County
Asthma	9.6%	9.3%	9.0%	8.8%	9.6%	9.0%
COPD	6.2%	7.3%	6.6%	5.8%	7.3%	5.9%
Diabetes	10.6%	9.9%	9.5%	8.0%	9.8%	8.0%
Heart Disease	4.0%	4.2%	5.7%	5.5%	6.0%	5.1%
High Blood Pressure	32.3%	30.4%	29.0%	27.1%	29.5%	27.5%
Kidney Disease	2.9%	2.7%	2.9%	2.5%	2.9%	2.5%
Stroke	3.2%	2.8%	3.0%	2.6%	3.2%	2.7%
Obesity	32.1%	30.4%	31.2%	31.3%	36.2%	28.9%

Source: National Center for Chronic Disease Prevention and Health Promotion, Division of Population Health. Behavioral Risk Factor Surveillance System, 2019

The health of the older adult population is critically important to the service area. Between 2011 and 2018 the population aged 65 and older increased in Nevada by 40.0%, while the population aged 85 and older increased by 25.0%. Nevada’s growth rate for the population age 85 and older is double the national rate and is expected to continue to age at higher rates through 2030.<sup>106</sup>

<sup>105</sup> United States & D.C., Median crude rates only.

<sup>106</sup> Nevada Department of Health & Human Services Aging & Disability Services Division, Elders Count Nevada 2021 Report. Link: [adsd.nv.gov/About/Reports/Reports/](https://adsd.nv.gov/About/Reports/Reports/)

## Older Adult Community

Approximately half of the older adult population in Carson City has hypertension, also referred to as high blood pressure.<sup>107</sup> Lyon County follows close behind at 47.0%. Over one-fifth of older adults in Lyon County have been told by a doctor, nurse, or other health professional that they have diabetes.

**Exhibit 161: Chronic Disease Prevalence in Older Adults (Aged 65+)**

AGED 65 AND OLDER	Nevada	Carson City	Douglas County	Lyon County	Storey County
Alzheimer’s Disease	8.0%	7.0%	7.0%	6.0%	5.0%
Asthma	4.0%	4.0%	4.0%	4.0%	3.0%
Arthritis (including Rheumatoid and Osteoarthritis)	29.0%	30.0%	32.0%	28.0%	22.0%
Chronic Kidney Disease	25.0%	21.0%	18.0%	21.0%	12.0%
Chronic Obstructive Pulmonary Disease (COPD)	9.0%	11.0%	7.0%	11.0%	9.0%
Diabetes (Excluding Diabetic Conditions Related to Pregnancy)	23.0%	18.0%	17.0%	22.0%	11.0%
Heart Failure	11.0%	10.0%	9.0%	9.0%	5.0%
Hypertension	49.0%	49.0%	45.0%	47.0%	43.0%
Osteoporosis	5.0%	6.0%	6.0%	4.0%	4.0%
Stroke	3.0%	4.0%	3.0%	3.0%	2.0%

Source: University of Nevada, Reno School of Medicine’s Office of Statewide Initiatives, Nevada Instant Atlas. Centers for Medicare & Medicaid Services Office of Minority Health Mapping Medicare Disparities Tool, 2020

- Approximately 21.0% of adults aged 65 and older in Carson City and Lyon County suffer from chronic kidney disease, a figure that is higher than other counties but lower than the state figure.

<sup>107</sup> National Center for Chronic Disease Prevention & Health Promotion Division for Heart Disease & Stroke Prevention. Link: [https://www.cdc.gov/bloodpressure/about.htm#:~:text=High%20blood%20pressure%2C%20also%20called,blood%20pressure%20\(or%20hypertension\).](https://www.cdc.gov/bloodpressure/about.htm#:~:text=High%20blood%20pressure%2C%20also%20called,blood%20pressure%20(or%20hypertension).)

## Cancer

The overall cancer-related mortality rate in Carson City is the highest within the service area at approximately 177.7 deaths per 100,000 population, followed by Lyon County.

**About the Data**  
Age-adjusted rates are per 100,000 persons unless otherwise specified.

**Exhibit 162: Cancer-related Mortality Rates**

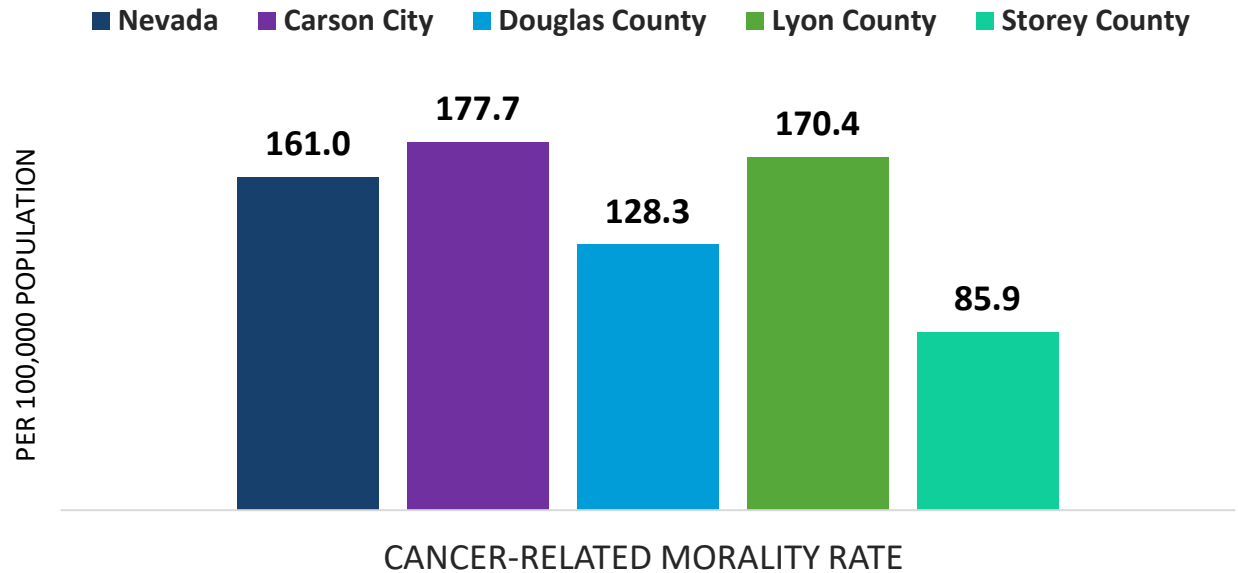

	Nevada	Carson City	Douglas County	Lyon County	Storey County
<b>Cancer-related morality rate</b>	161.0	177.7	128.3	170.4	85.9
Female Breast Cancer	22.3	17.4	15.7	18.8	ND
Prostate Cancer	20.9	26.7	20.8	21.3	8.7
Colorectal Cancer	16.0	20.1	11.7	17.5	ND
Lung and Bronchus Cancer	38.8	42.7	23.9	184.0	ND
Ovarian Cancer	7.1	6.2	5.8	9.4	5.7

Source: University of Nevada, Reno School of Medicine’s Office of Statewide Initiatives, Nevada Instant Atlas. Nevada Cancer Registry, 2019

- The Quad-County Region presents lower mortality rates related to breast cancer compared to Nevada’s state rate.
- Carson City has a notably higher rate of deaths related to prostate cancer compared to other service area counties (26.7 deaths per 100,000 population).
- Mortality rates for lung and bronchus cancer in Lyon County are high (184.0 per 100,000 population). This rate is four times higher than the state mortality rate (38.8) for lung

## QUAD-COUNTY REGIONAL COMMUNITY HEALTH NEEDS ASSESSMENT

and bronchus cancer. Carson City also has a higher mortality rate for lung and bronchus cancer (42.7) compared to the state figure.

Preventive healthcare services like screenings and check-ups are critical to early cancer detection and treatment.

### Exhibit 162: Time Since Last Pap Test

AGES 21 TO 65	Nevada
Within the past year (anytime less than 12 months ago)	39.9%
Within the past 2 years (1 year but less than 2 years ago)	16.1%
Within the past 3 years (2 years but less than 3 years ago)	11.1%
Within the past 5 years (3 years but less than 5 years ago)	8.1%
5 or more years ago	24.8%

Source: Centers for Disease Control & Prevention Nevada Behavioral Risk Factor Surveillance System Web Enabled Analysis Tool, 2020

### Exhibit 163: Trend of Women Who Have Had a Mammogram in the Past Two Years

AGED 40 & OLDER	Nevada
2020	69.6%
2018	66.4%
2016	67.0%

Source: Centers for Disease Control & Prevention Nevada Behavioral Risk Factor Surveillance System Web Enabled Analysis Tool, 2020

## Preventative Care

Preventive healthcare services like screenings, check-ups, and vaccinations are key to keeping people of all ages healthy. Many people do not get the preventive care they need. Barriers include cost, not having a primary care provider, living too far from providers, and lack of awareness about recommended preventive services. Vaccinations throughout childhood are important because they help provide immunity before children are exposed to potentially life-threatening diseases.<sup>108</sup>

**Exhibit 164: Influenza & Pneumonia Vaccinations Among Older Adults**

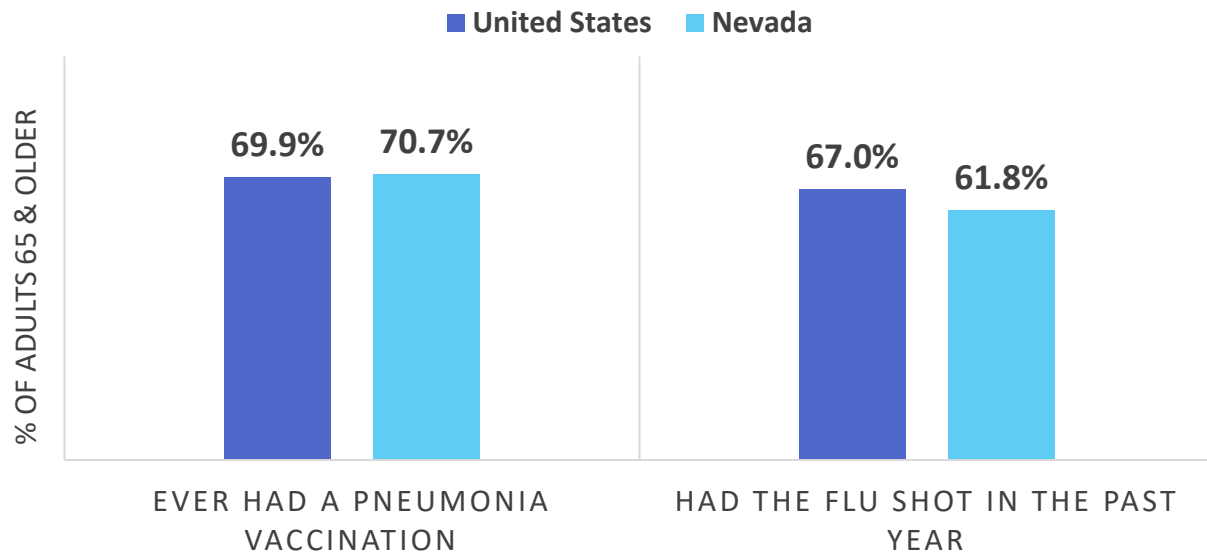

65 AND OLDER	United States	Nevada
Ever had a pneumonia vaccination	69.9%	70.7%
Had the flu shot in the past year	67.0%	61.8%

Source: National Center for Chronic Disease Prevention and Health Promotion, Division of Population Health. Behavioral Risk Factor Surveillance System Web Enabled Analysis Tool, 2020

<sup>108</sup> National Center for Immunization & Respiratory Diseases. Link: [cdc.gov/vaccines/parents/why-vaccinate/index.html](https://cdc.gov/vaccines/parents/why-vaccinate/index.html)

QUAD-COUNTY REGIONAL COMMUNITY HEALTH NEEDS ASSESSMENT

Exhibit 165: Influenza Vaccinations

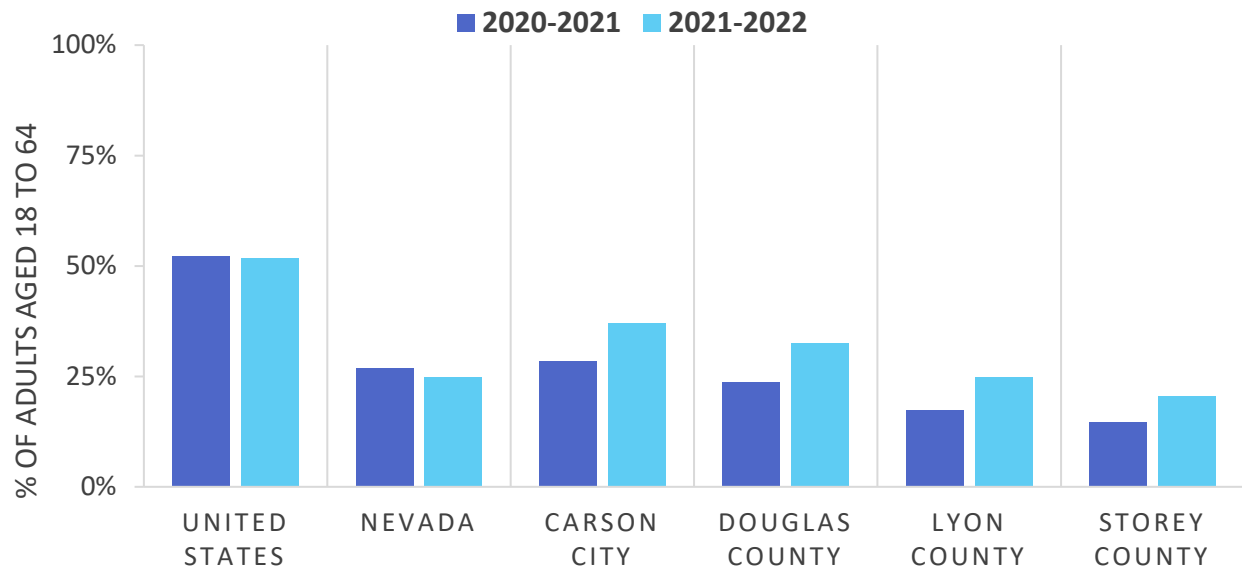

	United States	Nevada	Carson City	Douglas County	Lyon County	Storey County
2021-2022	52.1%	26.8%	28.5%	23.7%	17.3%	14.7%
2020-2021	51.8%	24.9%	37.1%	32.5%	24.7%	20.5%

Source: State of Nevada Department of Health & Human Services, Office of Analytics. Nevada Influenza Vaccinations



## Sexual Health

Due to the impact of the COVID-19 pandemic on HIV testing in the United States during 2020, the overall number of HIV diagnoses in the United States in 2020 (30,403) was 17% lower than in 2019 (36,585). The steep reduction in diagnoses in 2020 is likely due to disruptions in clinical care services, patient hesitancy in accessing clinical services, and shortages in HIV testing reagents/materials, which causes concern regarding underdiagnosis.<sup>109</sup>

Despite pandemic-related challenges, Nevada’s rate of new HIV diagnoses decreased by 25.5% between 2019 and 2020. However, the HIV and AIDS-related death rate increased slightly in Nevada, from six deaths per 100,000 population to 6.5 deaths per 100,000 population.

**Exhibit 166: Human Immunodeficiency Virus & Acquired Immunodeficiency Syndrome**

	United States		Nevada	
	2019	2020	2019	2020
HIV death rate	5.9	6.5	6.0	6.5
AIDS death rate	4.5	5.0	4.6	5.3
HIV prevalence	376.9	379.7	411.5	418.5
AIDS prevalence	192.3	191.4	190.8	191.7
HIV diagnoses	13.2	10.9	20.0	14.9

Source: Center for Disease Control & Prevention, National Center for HIV, Viral Hepatitis, STD & TB Prevention, 2019

**Exhibit 167: Sexually Transmitted Infections**

	Nevada		Carson City		Douglas County		Lyon County		Storey County	
	2019	2020	2019	2020	2019	2020	2019	2020	2019	2020
Primary/ Secondary Syphilis	26.2	24.9	14.3	12.5	2.0	6.1	7.0	8.7	0.0	24.3
Gonorrhea	211.6	206.6	75.1	78.7	45.0	53.2	53.9	114.8	48.5	48.5

Source: Center for Disease Control & Prevention, National Center for HIV, Viral Hepatitis, STD & TB Prevention, 2019

<sup>109</sup> National Center for HIV, Viral Hepatitis, STD, and TB Prevention. Link: [cdc.gov/nchhstp/](https://www.cdc.gov/nchhstp/)

## QUAD-COUNTY REGIONAL COMMUNITY HEALTH NEEDS ASSESSMENT

Similar to preventative screenings and routine check-ups, sexually transmitted infection (STI) testing was hindered in early 2020. Healthcare clinics closed entirely or limited in-person visits to symptomatic patients only while decreased routine healthcare visits, increased unemployment and loss of health insurance, as well as STI test kit and laboratory supply shortages, may have contributed to reduced screening during the pandemic.<sup>110</sup>

The incidence of chlamydia in youth ages 15 to 19 in Carson City is higher than state and national rates (2,188.6 cases per 100,000 population). Carson City also has the highest rates of chlamydia in youth ages 20 to 24, which is higher than national levels, but lower than state rates.

### About the Data

Incidence is a measure of the number of new cases of a characteristic that develop in a population in a specified time period. Researchers may study incident (new) cases of illnesses to help identify causes and prevent additional cases. Incidence is often reported for infectious diseases.

*National Institute of Mental Health*

### Exhibit 168: Incidence of Chlamydia in Youth

	United States	Nevada	Carson City	Douglas County	Lyon County	Storey County
Under 14	20.3	11.6	10.6	0.0	0.0	0.0
15 to 19	2,156.0	2,178.7	2,188.6	1,613.6	1,658.5	598.8
20 to 24	3,002.1	3,317.9	3,055.4	1,891.9	1,955.7	2,000.0

Source: Center for Disease Control & Prevention, National Center for HIV, Viral Hepatitis, STD & TB Prevention, 2019

### Exhibit 169: Incidence of Chlamydia in Adults

	United States	Nevada	Carson City	Douglas County	Lyon County	Storey County
25 to 29	1,448.6	1,547.3	1,357.7	876	843.4	549.5
30 to 34	729.7	849.2	578.2	367.3	427.8	571.4
35 to 39	389.6	454.5	535.1	78.7	196	555.6
40 to 44	215.9	281.6	165.9	84.4	329.6	934.6
45 to 54	99.0	140.3	102.2	74.5	59.9	0.0
55 to 64	32.9	43	0.0	11.3	11.9	0.0
65 and older	5.1	5.4	0.0	0.0	0.0	0.0

Source: Center for Disease Control & Prevention, National Center for HIV, Viral Hepatitis, STD & TB Prevention, 2019

<sup>110</sup> Centers for Disease Control & Prevention. Division of STD Prevention, National Center for HIV, Viral Hepatitis, STD & TB Prevention, 2022. Link: [cdc.gov/std/statistics/2020/impact.htm](https://cdc.gov/std/statistics/2020/impact.htm)

## QUAD-COUNTY REGIONAL COMMUNITY HEALTH NEEDS ASSESSMENT

- Carson City has the highest incidence of chlamydia in adults ages 25 to 29 with 1,357.7 newly diagnosed cases per 100,000 population.
- For ages 35 to 39, Storey County has the highest incidence of newly diagnosed cases of chlamydia (555.6) with Carson City close behind at 535.1 per 100,000 population. Both rates are higher than the state (454.5) and national levels (389.6).
- Newly diagnosed cases of chlamydia for ages 40 to 44 in Storey County are notably high: 934.6 per 100,000. This is four times higher than national rates and three times higher than state rates.

More than half of all high school students in the Quad-County service area self-reported condom use, with Lyon and Storey Counties having the highest rates (56.7%).

### Exhibit 170: Self-Reported Condom Use by High School Students

	Nevada	Carson City	Douglas County	Lyon & Storey County
Used a condom during last sexual intercourse	56.8%	55.2%	51.8%	56.7%

Source: State of Nevada, Division of Public and Behavioral Health and the University of Nevada, Reno. 2019 Nevada High School Youth Risk Behavior Survey Report

### Exhibit 171: Self-Reported Dating & Sexual Violence by High School Students<sup>111</sup>

	Nevada	Carson City	Douglas County	Lyon & Storey County
Physical dating violence	7.0%	13.7%	7.0%	7.4%
Sexual dating violence	12.6%	12.3%	13.4%	12.7%
Physically forced to have sexual intercourse	6.2%	6.9%	5.1%	7.6%

Source: State of Nevada, Division of Public and Behavioral Health and the University of Nevada, Reno. 2019 Nevada High School Youth Risk Behavior Survey Report

- The percentage of high school students who experienced physical or sexual dating violence in the past year (2019), indicates that Carson City high school students have experienced more physical dating violence in the past year compared to other service area counties. Lyon and Storey County have the highest percentage of high school students who reported ever being physically forced to have sexual intercourse in their lifetime.

<sup>111</sup> Physical dating violence: Including being hit, slammed into something, or injured with an object or weapon on purpose by someone they were dating or going out with. Sexual dating violence: Including kissing, touching, or physically forced to have sexual intercourse when they did not want to by someone they were dating or going out with.

**Maternal Health**

Over the past two decades, the United States maternal mortality rate has not improved while maternal mortality rates have decreased for other regions of the world. Significant racial and ethnic disparities persist in both the rate of women in the United States who die due to complications of pregnancy or delivery and the rate that women experience negative health consequences due to unexpected pregnancy or childbirth outcomes.<sup>112</sup>

The annual trend of birth rates for women aged 18 to 44 increased slightly in Douglas and Storey County and decreased slightly in other service area counties as well as statewide.

**About the Data**

**Annual Birth Rates:**  
Live Births Per 1,000 Women Aged 18 to 44

**Annual Teen Birth Rates:**  
Live Births Per 1,000 Women Aged 15 to 19

**Exhibit 172: Trend of Annual Birth Rates**

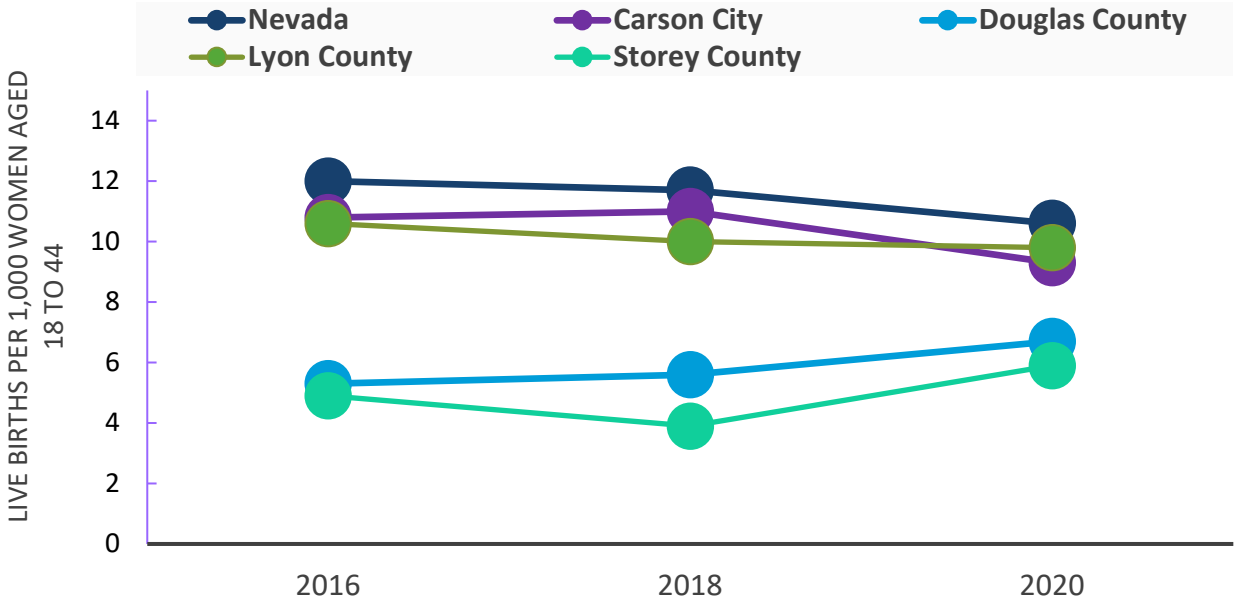

	Nevada	Carson City	Douglas County	Lyon County	Storey County
2020	10.6	9.3	6.7	9.8	5.9
2018	11.7	11.0	5.6	10.0	3.9
2016	12.0	10.8	5.3	10.6	4.9

Source: University of Nevada, Reno School of Medicine’s Office of Statewide Initiatives, Nevada Instant Atlas. Nevada Office of Health Statistics & Surveillance

<sup>112</sup> United States Commission on Civil Rights. *Racial Disparities in Maternal Health*, 2021. Link: [usccr.gov/files/2021/09-15-Racial-Disparities-in-Maternal-Health.pdf](https://www.usccr.gov/files/2021/09-15-Racial-Disparities-in-Maternal-Health.pdf)

## QUAD-COUNTY REGIONAL COMMUNITY HEALTH NEEDS ASSESSMENT

Counties with a small number of cases may be suppressed to protect the individual's confidentiality. Teen births have decreased between 2016 and 2020, predominantly in Carson City. The Quad-County Region has lower percentages of women who received prenatal care in their first trimester compared to women statewide. Between six and seven of ten expecting mothers received prenatal care within their first trimester.

**Exhibit 173: Trend of Annual Teen Birth Rate**

	Nevada	Carson City	Douglas County	Lyon County	Storey County
2020	21.6	30.7	8.1	16.6	26.1
2018	24.9	30.5	15.8	27.8	ND
2016	28.0	37.6	13.8	20.9	ND

Source: University of Nevada, Reno School of Medicine's Office of Statewide Initiatives, Nevada Instant Atlas. Nevada Office of Health Statistics & Surveillance

**Exhibit 174: Women Receiving Prenatal Care During First Trimester**

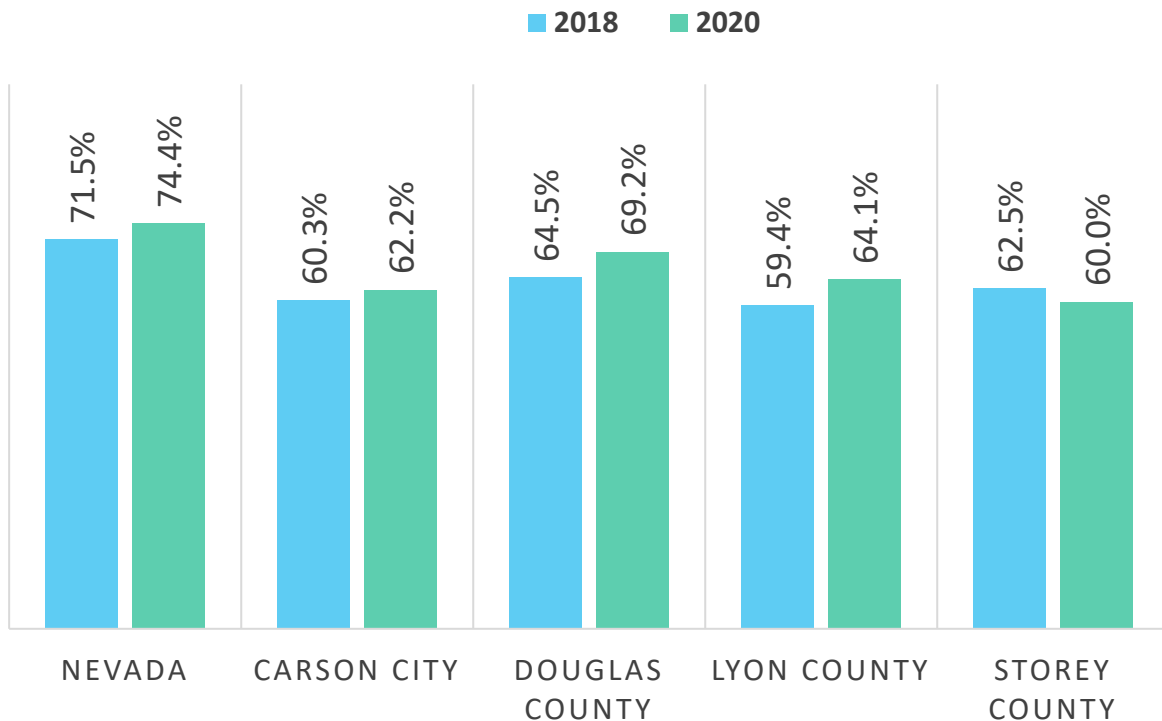

	Nevada	Carson City	Douglas County	Lyon County	Storey County
2020	74.4%	62.2%	69.2%	64.1%	60.0%
2018	71.5%	60.3%	64.5%	59.4%	62.5%

Source: University of Nevada, Reno School of Medicine's Office of Statewide Initiatives, Nevada Instant Atlas. Nevada Office of Health Statistics & Surveillance

## QUAD-COUNTY REGIONAL COMMUNITY HEALTH NEEDS ASSESSMENT

### Exhibit 175: Women’s Health Providers

	United States		Nevada		Carson City		Douglas County		Lyon County		Storey County	
	Rate	#	Rate	#	Rate	#	Rate	#	Rate	#	Rate	#
Obstetrics & Gynecology	12.5	ND	9.8	303	17.9	10	0.0	0	0.0	0	0.0	0

Source: University of Nevada, Reno School of Medicine’s Office of Statewide Initiatives, Nevada Instant Atlas. Health Resources & Services Administration, Area Health Resource Files, 2019

- Carson City is the only area within the Quad-County Region with obstetric providers and/or gynecologists, indicating a possible risk of other service area counties becoming a maternity care desert. Maternity care deserts are areas within geographies, like counties, with no hospital staff trained to provide care for pregnant women and no specialists or certified nurse midwives to deliver babies.<sup>113</sup>

### Exhibit 176: Infant Mortality Rate

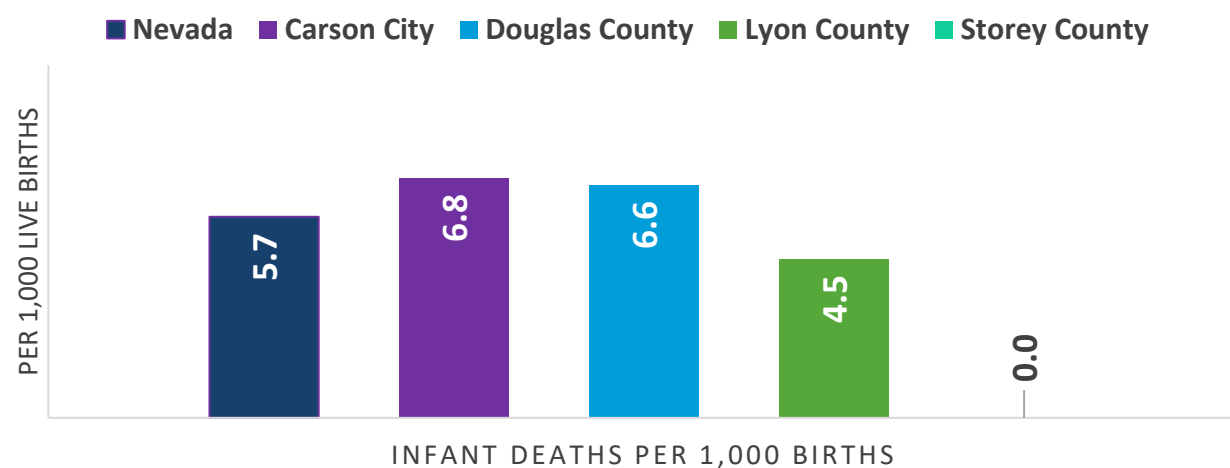

Nevada	Carson City	Douglas County	Lyon County	Storey County
5.7	6.8	6.6	4.5	0.0

Source: Nevada Dept. of Health & Human Services Office of Analytics. 2021 Nevada Health Profiles

### Exhibit 177: Birth Weight

Per 1,000 Live Births	Nevada	Carson City	Douglas County	Lyon County	Storey County
Under 5.5 Pounds	88.7	86.7	87.5	84.1	0.0

Source: Nevada Dept. of Health & Human Services Office of Analytics. 2021 Nevada Health Profiles

<sup>113</sup> RTI Health Advance. *Lost in the Maternity Care Desert: The Worsening Crisis in Rural Obstetrics Care*, 2022. Link: [healthcare.rti.org/insights/maternity-care-deserts-rural-obstetrics](https://healthcare.rti.org/insights/maternity-care-deserts-rural-obstetrics)

## QUAD-COUNTY REGIONAL COMMUNITY HEALTH NEEDS ASSESSMENT

### Exhibit 178: Reported Abortion Rate

PER 1,000 WOMEN AGED 15 TO 44	Nevada
Abortions reported in Nevada	14.0
Abortions obtained by out-of-state residents	5.2

Source: Centers for Disease Control & Prevention. Morbidity and Mortality Weekly Report Abortion Surveillance, 2019

### Exhibit 179: Reported Abortions by Known Race & Ethnicity

	Nevada
White	37.0%
Black	18.4%
Other	12.0%
Hispanic	32.6%
<b>Total abortions reported by known race &amp; ethnicity</b>	<b>91.2%</b>

Source: Centers for Disease Control & Prevention. Morbidity and Mortality Weekly Report Abortion Surveillance, 2019

### Exhibit 180: Reported Abortions Among Adolescents in Nevada

PER 1,000 WOMEN	Percent	Number
Under 15	2.7%	19
15	5.2%	37
16	8.7%	62
17	14.2%	101
18	30.8%	219
19	38.3%	272
<b>Total number of abortions, ages 0 to 19</b>	<b>100.0%</b>	<b>710</b>

Source: Centers for Disease Control & Prevention. Morbidity and Mortality Weekly Report Abortion Surveillance, 2019

### Exhibit 181: Reported Abortions Among Adults in Nevada

PER 1,000 WOMEN	Percent	Number
15-19	8.6%	691
20-24	27.2%	2,200
25-29	27.9%	2,257
30-34	20.2%	1,630
35-39	11.4%	918
≥40	4.5%	363
<b>Total abortions reported by known age</b>	<b>96.0%</b>	<b>8,078</b>

Source: Centers for Disease Control & Prevention. Morbidity and Mortality Weekly Report Abortion Surveillance, 2019

## Maternal Substance Use

Alcohol and other harmful substances can cause problems during pregnancy and affect the health of babies both before and after birth.<sup>114</sup>

Across Carson City, Douglas County, and Lyon County, the percentage of pregnant women abstaining from alcohol consumption has decreased, most

significantly in Douglas County, which decreased from 99.6% in 2016 to 90.4% in 2020. Since 2016, the percentage of pregnant women abstaining from smoking in Carson City, Douglas County, and Lyon County have increased slightly. The opposite is true in Storey County, where rates have decreased slightly since 2016.

As of 2022, Opioid use within subpopulations within Nevada increased, including pregnant women. The number of women who self-reported the use of heroin and other opioids during pregnancy has quadrupled since 2012, while neonatal opioid exposure has doubled.

*Nevada Resiliency Fund: Opioid Needs Assessment, 2022*

### Exhibit 182: Trend of Pregnant Women Abstaining from Alcohol Consumption

	Nevada	Carson City	Douglas County	Lyon County	Storey County
2020	96.2%	97.7%	90.4%	97.5%	100.0%
2018	97.0%	97.7%	91.6%	98.6%	100.0%
2016	ND	99.2%	99.6%	99.1%	100.0%

Source: University of Nevada, Reno School of Medicine’s Office of Statewide Initiatives, Nevada Instant Atlas. Nevada Office of Health Statistics & Surveillance

### Exhibit 183: Trend of Pregnant Women Abstaining from Smoking Tobacco

	Nevada	Carson City	Douglas County	Lyon County	Storey County
2020	94.8%	90.5%	93.1%	87.7%	92.0%
2018	94.6%	91.6%	91.2%	85.0%	93.8%
2016	ND	89.4%	92.2%	85.2%	95.0%

Source: University of Nevada, Reno School of Medicine’s Office of Statewide Initiatives, Nevada Instant Atlas. Nevada Office of Health Statistics & Surveillance

<sup>114</sup> State of Nevada, Alcohol Or Drug Use During Pregnancy. Link: <https://state.nv.networkofcare.org/ph/library/article.aspx?hwid=ae1198>



## Behavioral Risk Factors

Risk factors are characteristics at the biological, psychological, family, community, or cultural level that precedes and are associated with a higher likelihood of negative outcomes.

Individual-level risk factors may include a person’s genetic predisposition to addiction or exposure to alcohol prenatally.<sup>115</sup>

### Exhibit 184: Risk Factors

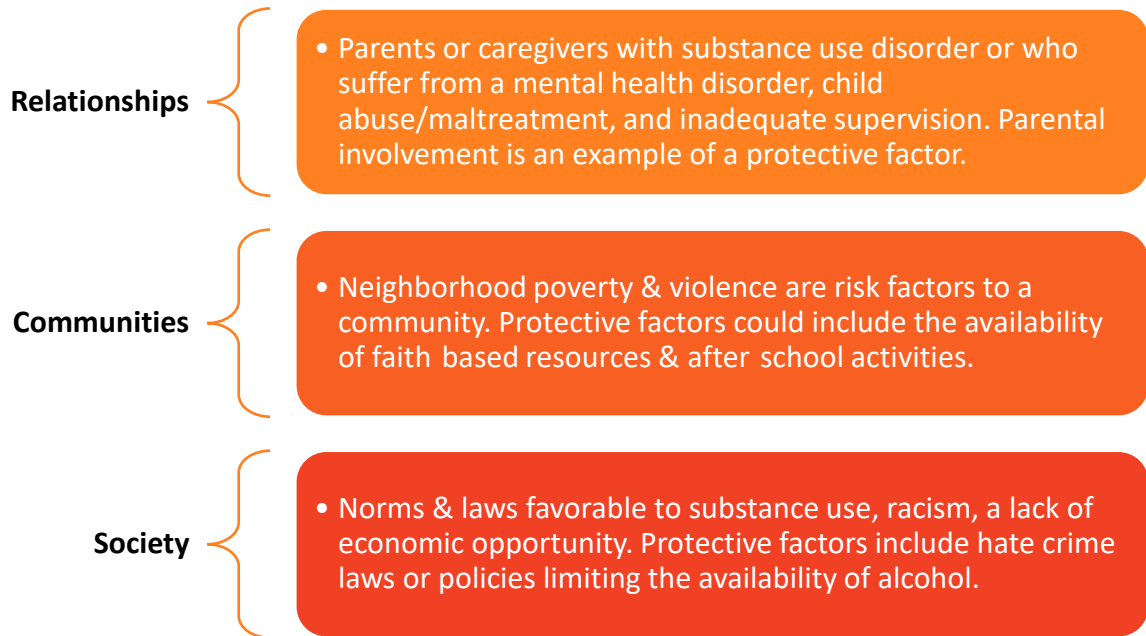

Source: Substance Abuse and Mental Health Services Administration, Risk & Protective Factors

<sup>115</sup> SAMHSA, Risk & Protective Factors. Link: [samhsa.gov/sites/default/files/20190718-samhsa-risk-protective-factors.pdf](https://www.samhsa.gov/sites/default/files/20190718-samhsa-risk-protective-factors.pdf)

## QUAD-COUNTY REGIONAL COMMUNITY HEALTH NEEDS ASSESSMENT

Insufficient sleep is associated with numerous chronic diseases and conditions, such as diabetes, cardiovascular disease, hypertension, obesity, and depression.<sup>116</sup> The age-adjusted percentage of adults who report fewer than seven hours of sleep on average ranges from only 34.7% in Douglas County to 38.5% in Carson City. One-third (or fewer) high school students across the service area get sufficient sleep. Only one-third of middle school students in Lyon County get sufficient sleep. Additionally, nearly six in ten middle school students in Carson City and Douglas County, and half of those in Storey County, get sufficient sleep.

### Exhibit 185: Sleep Indicators

	Nevada	Carson City	Douglas County	Lyon County	Storey County
Adults who got insufficient sleep <sup>117</sup>	ND	38.5%	34.7%	37.7%	35.5%
High School Students who got sufficient sleep <sup>118</sup>	21.6%	24.8%	30.7%	33.3%	21.6%
Middle School students who got sufficient sleep <sup>119</sup>	50.0%	58.5%	59.2%	33.3%	50.0%

Source: National Center for Chronic Disease Prevention and Health Promotion, Division of Population Health. Behavioral Risk Factor Surveillance System, 2019 Source: State of Nevada, Division of Public and Behavioral Health and the University of Nevada, Reno. 2019 Nevada High School & Middle School Youth Risk Behavior Survey Report

### Exhibit 186: Additional Safety Indicators

	Nevada	Carson City	Douglas County	Lyon & Storey County
High school students who texted or e-mailed while driving a car in the past 30 days	31.0%	39.3%	51.4%	36.3%
High school students who carried a gun within the past year	5.3%	8.2%	4.7%	5.1%

Source: State of Nevada, Division of Public and Behavioral Health and the University of Nevada, Reno. 2019 Nevada High School Youth Risk Behavior Survey Report

<sup>116</sup> National Center for Chronic Disease Prevention & Health Promotion, Division of Population Health, Sleep & Chronic Disease. Link: [cdc.gov/sleep/about\\_sleep/chronic\\_disease.html](https://cdc.gov/sleep/about_sleep/chronic_disease.html)

<sup>117</sup> Age-adjusted percentage of adults who report fewer than 7 hours of sleep on average.

<sup>118</sup> Percentage of high school students who had 8 or more hours of sleep on an average school night.

<sup>119</sup> Percentage of high school students who had 9 or more hours of sleep on an average school night.

## Behavioral Health

Behavioral health is the promotion of mental health, resilience, and well-being; the treatment of mental and substance use disorders; and the support of those who experience and/or are in recovery from these conditions, along with their families and communities.<sup>120</sup>

The pandemic exacerbated the need for behavioral health services while individuals with existing disorders faced additional barriers to care. However, even before the COVID-19 public health emergency, the demand for behavioral health services was on the rise.<sup>121</sup>

Residents in Lyon County reported having an average of 4.4 poor physical health days, higher than state (4.2) and national (3.4) averages and the surrounding counties. The number of poor mental health days is highest in Lyon County (4.9).

## QUALITY OF LIFE

**Poor Mental Health Days.** Average number of mentally unhealthy days reported in the past 30 days.

**Poor Physical Health Days.** Average number of physically unhealthy days reported in the past 30 days, based on responses to the Behavioral Risk Factor Surveillance System question: “Now thinking about your physical health, which includes physical illness and injury, for how many days during the past 30 days was your physical health not good?” The value reported is the average number of days a county’s adult respondents report that their physical health was not good.

**Frequent Mental Distress.** Percentage of adults who reported 14 or more days in response to the question, “Now, thinking about your mental health, which includes stress, depression, and problems with emotions, for how many days during the past 30 days was your mental health not good?”

**Exhibit 187: Quality of Life**

	United States	Nevada	Carson City	Douglas County	Lyon County	Storey County
Poor physical health days	3.4	4.2	4.2	3.7	4.4	3.7
Poor mental health days	4.0	4.7	4.6	4.4	4.9	4.4

Source: National Center for Chronic Disease Prevention and Health Promotion, Division of Population Health. Behavioral Risk Factor Surveillance System, 2019

<sup>120</sup> SAMHSA, *Behavioral Health Integration*. Link: [samhsa.gov/sites/default/files/samhsa-behavioral-health-integration.pdf](https://www.samhsa.gov/sites/default/files/samhsa-behavioral-health-integration.pdf)

<sup>121</sup> *Addressing the Behavioral Health Crisis*, 2021. Link: [kaufmanhall.com/insights/article/addressing-behavioral-health-crisis?mkt\\_tok=NjU0LUNOWS0yMjQAAAF9kEL2kL79N9Mo4sGYHi1sFIY31e4Zh2FSnt2ppR-zBzwBvGB5Q5aoMP9ABHvMQFFjpLpEkh0aXAESLf9JLR\\_f6Dsy-twIMr7j-4MxolXLep1p](https://www.kaufmanhall.com/insights/article/addressing-behavioral-health-crisis?mkt_tok=NjU0LUNOWS0yMjQAAAF9kEL2kL79N9Mo4sGYHi1sFIY31e4Zh2FSnt2ppR-zBzwBvGB5Q5aoMP9ABHvMQFFjpLpEkh0aXAESLf9JLR_f6Dsy-twIMr7j-4MxolXLep1p)

## QUAD-COUNTY REGIONAL COMMUNITY HEALTH NEEDS ASSESSMENT

Nevada is no longer in the top 10 states for suicides, and now ranks 12<sup>th</sup> in the nation, according to a report by Suicide Awareness Voices of Education (SAVE). In 2019, Nevada ranked among states in suicide rates, with 642 deaths resulting in an age-adjusted rate of 19.8 suicides per 100,000 population. In 2020, Nevada moved to twelfth on the list with 603 deaths, a rate of 19.2. According to Nevada’s Office of Suicide Prevention, the number of suicides in Nevada has held steady or decreased, while the country has seen an uptick.<sup>122</sup>

### About the Data

The suicide rate for the total population of each county measures the number of suicides in a given time period (2016-2020) divided by the average number of people at risk during that period.

Among the Quad-Counties, the suicide rate is highest in Carson City, with 30 suicides per 100,000 population, followed by Douglas County with 29 suicides per 100,000 population.

### Exhibit 188: Suicide Rate

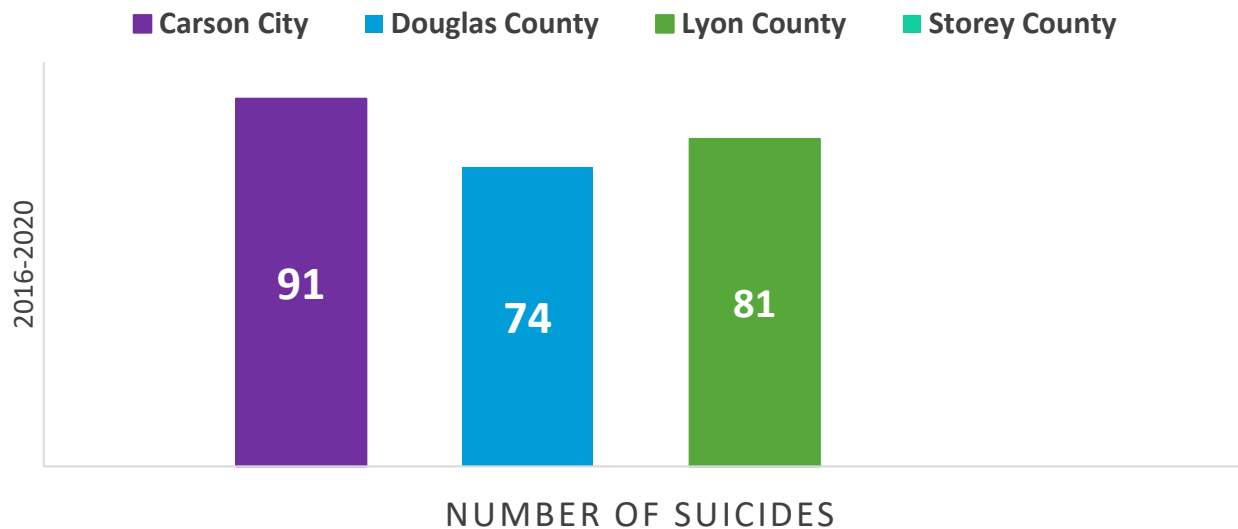

	Nevada	Carson City	Douglas County	Lyon County	Storey County
Number of suicides	3,152	91	74	81	ND
Per 100,000 population	ND	30	29	26	ND

Source: National Center for Health Statistics, 2016-2020 Mortality Files

- The statewide number of suicides only represent the sum of deaths of counties who reported data and may not accurately reflect the total number of suicide-related deaths between 2016 and 2020.

Over half of adults in Nevada reported having a mental illness and did not receive treatment. And over a quarter of adults reported an unmet need for treatment.

<sup>122</sup> Nevada Department of Health & Human Services. Nevada Drops in National Ranking for Suicides, 2022. Link: [dhhs.nv.gov/Reports/Press\\_Releases/2022/Nevada\\_Drops\\_in\\_National\\_Ranking\\_for\\_Suicides/](https://dhhs.nv.gov/Reports/Press_Releases/2022/Nevada_Drops_in_National_Ranking_for_Suicides/)

QUAD-COUNTY REGIONAL COMMUNITY HEALTH NEEDS ASSESSMENT

Exhibit 189: Adult Mental Health Indicators

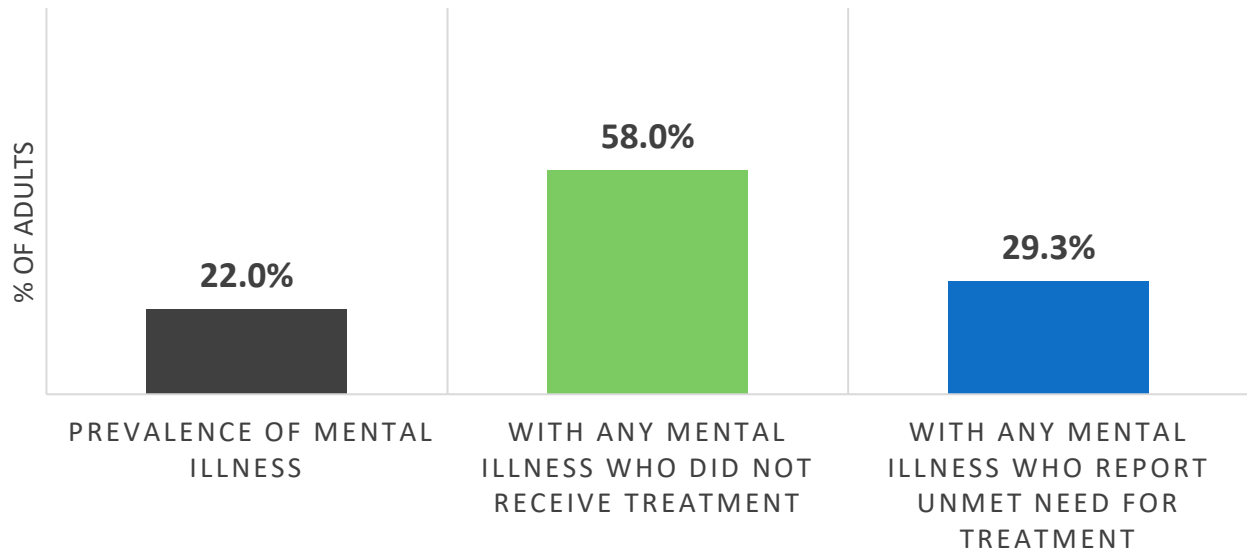

	Nevada
Prevalence of Mental Illness	22.0%
With any mental illness who did not receive treatment	58.0%
With any mental illness who report unmet need for treatment	29.3%

Source: Substance Abuse and Mental Health Services Administration, Center for Behavioral Health Statistics and Quality. National Survey on Drug Use and Health, 2019

## Mental Health of Older Adults

The COVID-19 pandemic has exacerbated social isolation and loneliness, as well as other issues that older adults commonly face. Stay-at-home and social distancing mandates during the COVID-19 pandemic have forced nearly everyone to become more socially isolated than ever before.<sup>123</sup>

The mental health of older adults is critical to the Quad-County Region, as adults aged 65 and older make up nearly a quarter of the PSA (23.6%). In Storey County alone, nearly one in three members of the population is aged 65 and older.

Carson City and Storey County have the highest rates of depression among older adults (14.0%), higher than the statewide rate (12.0%).

### Exhibit 190: Mental Health Disorders in Older Adults

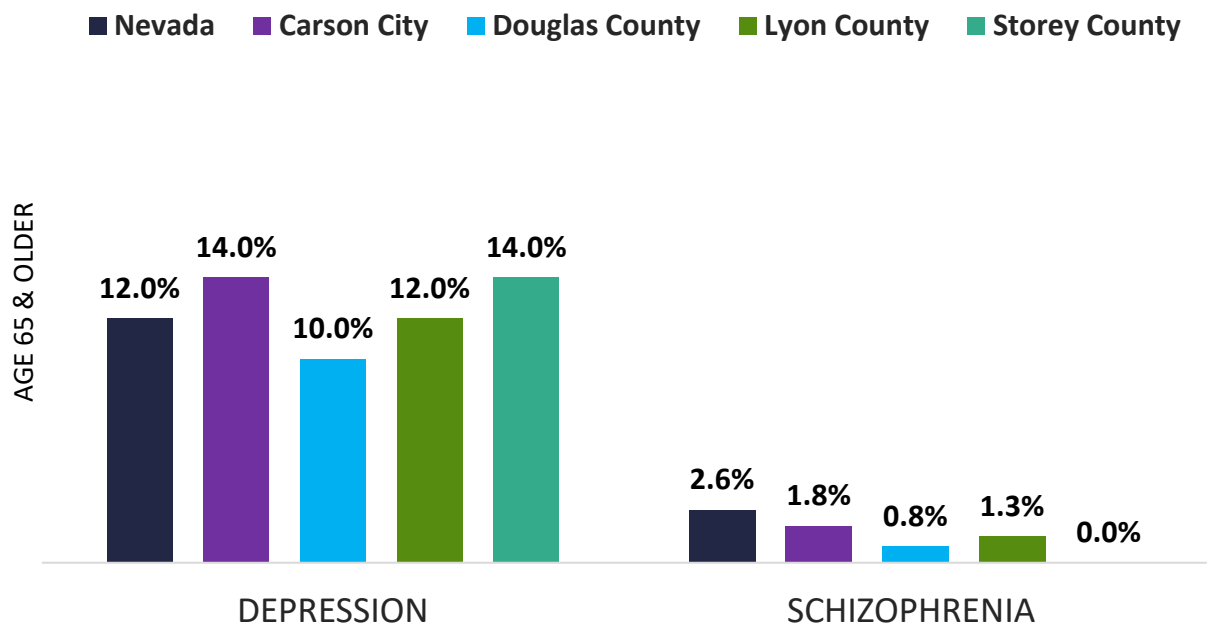

Source: Centers for Medicare and Medicaid Services (CMS) Mapping Medicare Disparities by Population data via the University of Nevada, Reno School of Medicine’s Office of Statewide Initiatives, [Nevada Instant Atlas](#).

<sup>123</sup> National Council on Aging, Inc. COVID-Driven Isolation Can Be Dangerous for Older Adults, 2021. Link: [ncoa.org/article/covid-driven-isolation-can-be-dangerous-for-older-adults](https://ncoa.org/article/covid-driven-isolation-can-be-dangerous-for-older-adults)

## Youth Behavioral Health

The data below offer a baseline of key mental health indicators self-reported by middle and high school students pre-pandemic.

Before the pandemic, approximately one in eight children had a type of anxiety disorder nationwide. Within the first few months of the pandemic, that proportion doubled.

From 2019 to 2021, emergency department visits for

*“The challenges today’s generation of young people face are unprecedented and uniquely hard to navigate. And the effect these challenges have had on their mental health is devastating.”*

### About the Data

Due to the pandemic and change in administration, the CDC was delayed in getting 2021 Youth Risk Behavior Survey data out to states. As a result, 2019 Youth Risk Behavior Survey data is the most recent available data for this CHNA report.

suspected suicide attempts increased by

51.0% for girls and four percent for adolescent boys.<sup>124</sup>

In 2019, approximately 35.8% to 40.2% of high school students in each county reported feeling sad or hopeless for two weeks or more in a row in the past year. More concerning, 53.6% to 56.4% of high school students self-reported never or rarely getting the help they need when they felt sad, empty, hopeless, angry, or anxious.

Approximately 44.6% to 56.0% of middle school students self-reported receiving the kind of help they need when they felt sad, empty, hopeless, angry, or anxious.

### Exhibit 191: Self-reported Youth Mental Health Indicators

2019	Nevada	Carson City	Douglas County	Lyon & Storey counties
High school students who felt sad or hopeless for two weeks or more in a row in the past year	40.7%	40.2%	35.8%	36.2%
High school students who never or rarely got the kind of help they need when they felt sad, empty, hopeless, angry, or anxious	56.2%	53.7%	53.6%	56.4%
Middle school students who felt sad or hopeless for two weeks or more in a row in the past year	34.4%	40.5%	29.5%	34.2%
Middle school students who ever got the kind help they need when they felt sad, empty, hopeless, angry, or anxious	49.9%	44.6%	46.9%	56.0%

Source: State of Nevada, Division of Public and Behavioral Health and the University of Nevada, Reno. 2019 Nevada High School & Middle School Youth Risk Behavior Survey Report

<sup>124</sup> Harvard Magazine. No Going Back to Normal, 2022. Link: <https://www.harvardmagazine.com/2022/07/feature-childrens-mental-health>

**Exhibit 192: Self-Reported Youth Suicide-related Indicators**

GRADES 9 TO 12	Nevada	Carson City	Douglas County	Lyon & Storey County
Created a suicide plan	15.3%	14.9%	17.0%	12.9%
Attempted suicide	8.9%	11.2%	6.3%	8.4%
Attempting suicide resulting in an injury, poisoning, or overdose that had to be treated by a doctor or nurse	2.8%	4.4%	2.2%	2.6%
Self-harmed without wanting to die	20.9%	20.6%	17.8%	17.9%

Source: State of Nevada, Division of Public and Behavioral Health and the University of Nevada, Reno. 2019 Nevada High School Youth Risk Behavior Survey Report

- Approximately 12.9% to 17.0% of high school students self-reported creating a suicide plan at least once within the service area.
- Over one in 10 high school students in Carson City reported attempting suicide in the past year. Of those attempts, 4.4% resulted in a condition that required treatment by a doctor or nurse. Additionally, one in five Carson City high school students reported self-harming without wanting to die.

**Exhibit 193: Additional Youth Mental Health Indicators**

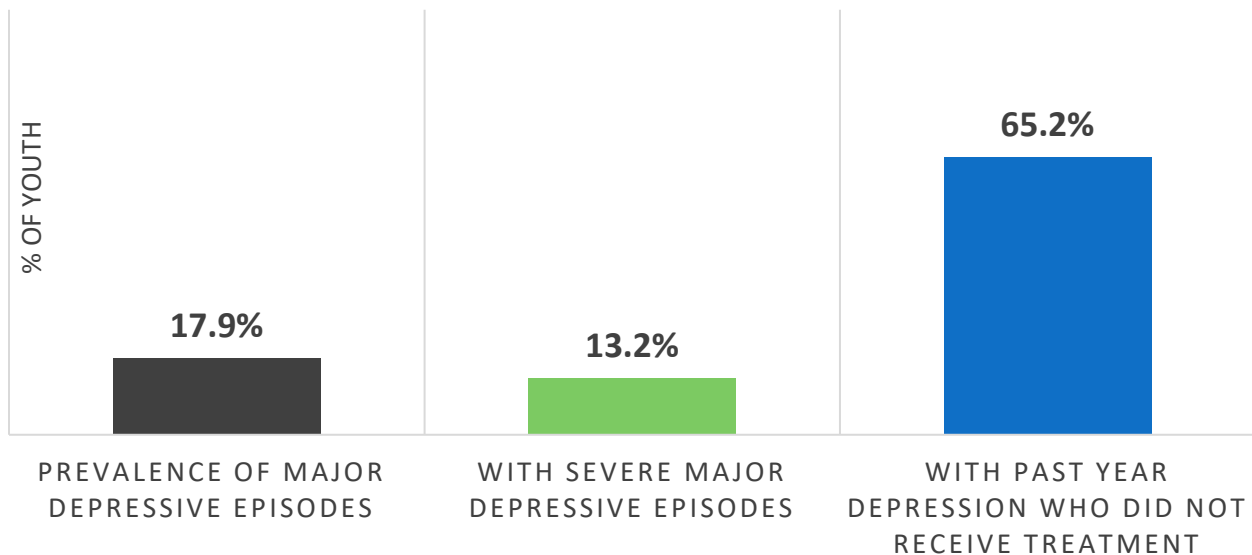

	Nevada
Prevalence of Major Depressive Episodes	17.9%
With Severe Major Depressive Episodes	13.2%
With past year depression who did not receive treatment	65.2%

Source: Substance Abuse and Mental Health Services Administration, Center for Behavioral Health Statistics and Quality. National Survey on Drug Use and Health, 2019



## Substance Use

Between 2017 and 2019, Lyon County experienced the highest rate of substance use-related deaths per 100,000 population, over twice as high compared to Douglas County.

The mortality rate in Lyon County is the below indicate deaths per 100,000 population which occurred between 2017 and 2019.<sup>125</sup>

### About the Data

Substance use-related mortality rates include accidental poisonings, intentional self-poisonings, and assault by drug poisonings, and drug poisoning of undetermined intent for drug-related overdose deaths and where any of the following opioid-related substances contributed to the cause of death: opium, heroin, natural and semi-synthetic opioids, methadone, synthetic opioids, and other/unspecified opioids.

Exhibit 194: Substance Use-related Mortality Rate

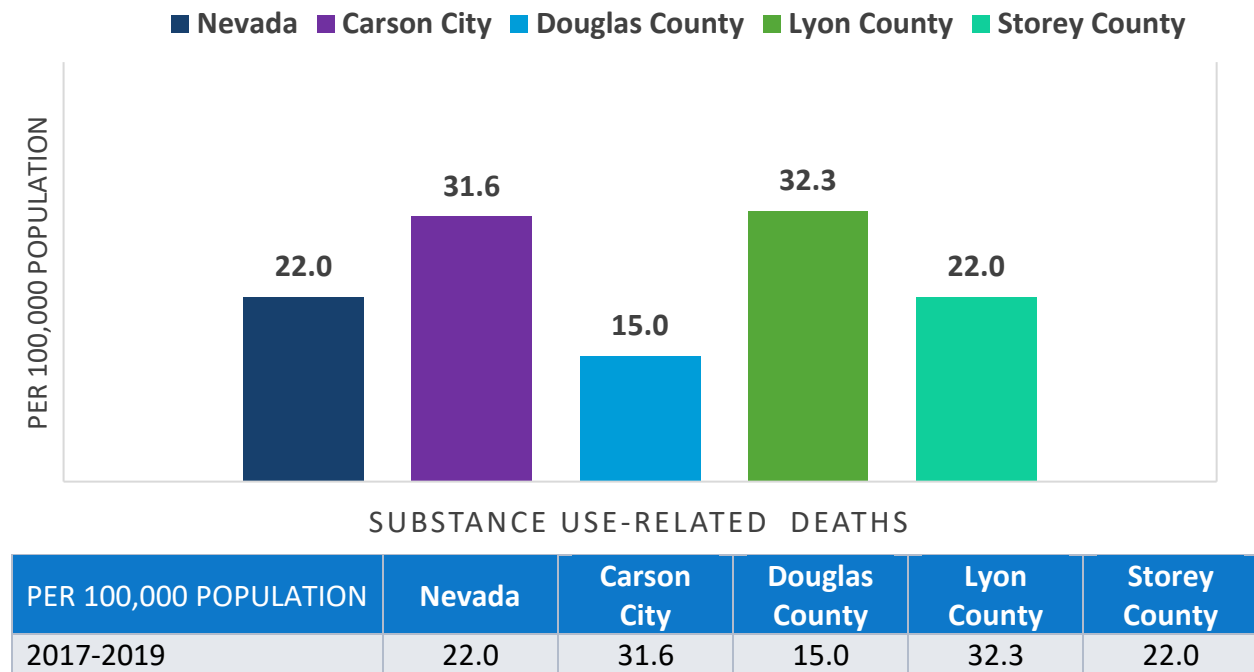

Source: State of Nevada Department of Health & Human Services Office of Analytics. 2021 Nevada Health Profiles

High school students report using electronic vapor products, alcohol, and/or marijuana, and to a lesser degree, cigarettes and/or prescription pain medicine, at some point in their lives.

<sup>125</sup> State of Nevada Department of Health & Human Services Office of Analytics. Nevada Health Profiles, 2021. Link: <https://app.powerbigov.us/view?r=eyJrjoiNDMzMzgwNzltMmVkZS00YTAzLThmNmYtMzgzMWM0NWRkOGxliwidCl6ImU0YTM0MGU2LWI4OWU0tNGU2OC04ZWFlLTE1NDRkMjcwMzk4MCI9>

## QUAD-COUNTY REGIONAL COMMUNITY HEALTH NEEDS ASSESSMENT

More than half of all students in the service area reported using electronic vapor products. The state average is 43.5%. Approximately one in five high school students in the Quad-County reported using prescription pain medicine. Rates are highest in Carson City (21.7%) and lowest in Lyon and Storey Counties (17.1%).

**Exhibit 195: High School Student Self-Reported Lifetime Substance Use<sup>126</sup>**

GRADES 9 TO 12	Nevada	Carson City	Douglas County	Lyon & Storey County
Alcohol	56.9%	63.1%	69.3%	63.1%
Cigarettes	18.0%	24.7%	21.4%	28.7%
Cocaine	5.2%	10.6%	8.9%	6.2%
Ecstasy	4.8%	6.5%	8.7%	6.3%
Electronic vapor products <sup>127</sup>	43.5%	61.4%	58.0%	57.7%
Heroin	2.5%	2.8%	1.9%	2.5%
Injectable Substances	2.2%	2.2%	1.2%	2.9%
Marijuana	35.4%	48.0%	40.5%	39.2%
Methamphetamines <sup>128</sup>	2.9%	5.5%	1.8%	3.8%
Prescription Pain Medicine <sup>129</sup>	18.8%	21.7%	18.2%	17.1%

Source: State of Nevada, Division of Public and Behavioral Health and the University of Nevada, Reno. 2019 Nevada High School Youth Risk Behavior Survey Report

- Nearly 70.0% of Douglas County high school students reported using alcohol. The percentages are slightly lower in the surrounding counties.
- Nearly half of Carson City high school students reported using marijuana (48.0%). Percentages are about 10 percentage points lower in the surrounding counties.
- Approximately one in three high school students in Lyon and Storey Counties reported using cigarettes (28.7%). The percentage is a bit lower in Carson City (24.7%).
- One in 10 high school students in Carson City reported using cocaine. Douglas, Lyon, and Storey County percentages are above the state (5.2%).

<sup>126</sup> Percentage of students who answered, 'yes'.

<sup>127</sup> Including e-cigarettes, vapes, vape pens, e-cigars, e-hookahs, hookah pens, and mods such as JUUL, Vuse, MarkTen, and blu

<sup>128</sup> Used methamphetamines (also called "speed", "crystal meth", "crank", "ice", or "meth").

<sup>129</sup> Percentage of high school students who ever took prescription pain medicine without a doctor's prescription or differently than prescribed (codeine, Vicodin, OxyContin, Hydrocodone, and Percocet).

## QUAD-COUNTY REGIONAL COMMUNITY HEALTH NEEDS ASSESSMENT

Nearly four in ten Carson City high school students (38.8%) report current use of electronic vapor products. Approximately 35.0% of high school students report using electronic vapor products in Lyon and Storey Counties. Nearly one-third of Carson City high school students currently use marijuana. Over seven percent of high school students in Lyon and Storey counties currently use prescription pain medicine.

### About the Data

Current use reflects the percentage of high school students who reported substance use during the 30 days before the survey.

**Exhibit 196: High School Student Self-Reported Current Substance Use<sup>130</sup>**

GRADES 9 TO 12	Nevada	Carson City	Douglas County	Lyon & Storey County
Alcohol	23.9%	26.8%	31.6%	29.0%
Binge Drinking	11.5%	18.6%	19.1%	18.0%
Cigarettes	3.6%	5.5%	5.9%	6.8%
Electronic Vapor Products	22.5%	38.8%	14.6%	35.0%
Marijuana	18.8%	30.3%	21.5%	16.3%
Prescription Pain Medicine	8.3%	5.9%	6.3%	7.5%

Source: State of Nevada, Division of Public and Behavioral Health and the University of Nevada, Reno. 2019 Nevada High School Youth Risk Behavior Survey Report

**Exhibit 197: High School Student Self-Reported Current Marijuana Use**

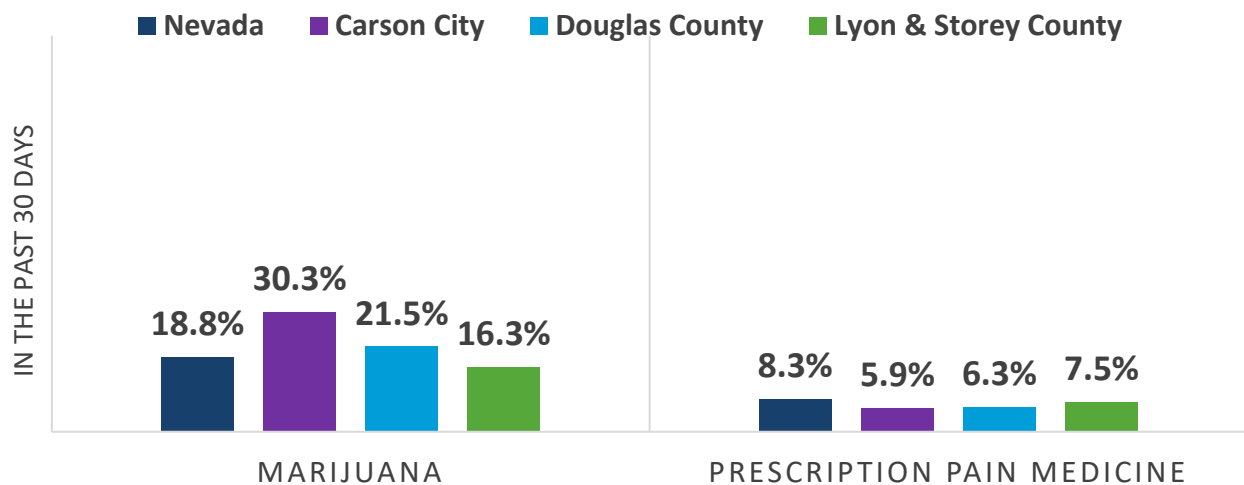

Source: State of Nevada, Division of Public and Behavioral Health and the University of Nevada, Reno. 2019 Nevada High School Youth Risk Behavior Survey Report

<sup>130</sup> Percentage of high school students who reported substance use during the 30 days before the survey.

## QUAD-COUNTY REGIONAL COMMUNITY HEALTH NEEDS ASSESSMENT

Quad-County Region middle school students self-reported lifetime use of electronic vapor products, alcohol, and marijuana, prescription pain medicine, and cigarettes at higher rates than any other substances.

The highest percentages of self-reported lifetime substance use are in Carson City for electronic vapor products (35.9%) – over one in three middle school students.

Over seventeen percent of Lyon and Storey Counties middle school students reported using marijuana. The number is slightly lower in Carson City (16.9%). Approximately fourteen percent of middle school students in Carson City and Lyon and Storey Counties have used prescription pain medicine.

### Exhibit 198: Middle School Student Self-Reported Lifetime Use<sup>131</sup>

GRADES 6 TO 8	Nevada	Carson City	Douglas County	Lyon & Storey County
Alcohol	29.2%	33.1%	23.8%	35.3%
Cigarettes	9.9%	11.6%	10.9%	18.3%
Cocaine	1.7%	3.7%	1.0%	2.9%
Ecstasy	1.7%	3.4%	0.0%	2.4%
Electronic vapor products	22.4%	35.9%	22.8%	29.8%
Heroin	0.7%	3.0%	0.0%	0.6%
Marijuana	13.4%	16.9%	9.5%	17.4%
Methamphetamines	1.1%	2.9%	1.8%	4.0%
Prescription Pain Medicine	10.4%	14.0%	8.5%	13.9%

Source: State of Nevada, Division of Public and Behavioral Health and the University of Nevada, Reno. 2019 Nevada Middle School Youth Risk Behavior Survey Report

<sup>131</sup> \*Due to small cell size, we caution against group comparisons for lifetime cocaine, heroin, and methamphetamine use.

## QUAD-COUNTY REGIONAL COMMUNITY HEALTH NEEDS ASSESSMENT

Nearly one-quarter of Carson City middle school students reported current use of electronic vapor products. Nearly one in five Lyon or Storey County middle school students (17.0%) reported current alcohol use. More than seven percent of Carson City middle school students reported current use of prescription pain medicine.

**Exhibit 199: Middle School Student Self-Reported Current Substance Use**

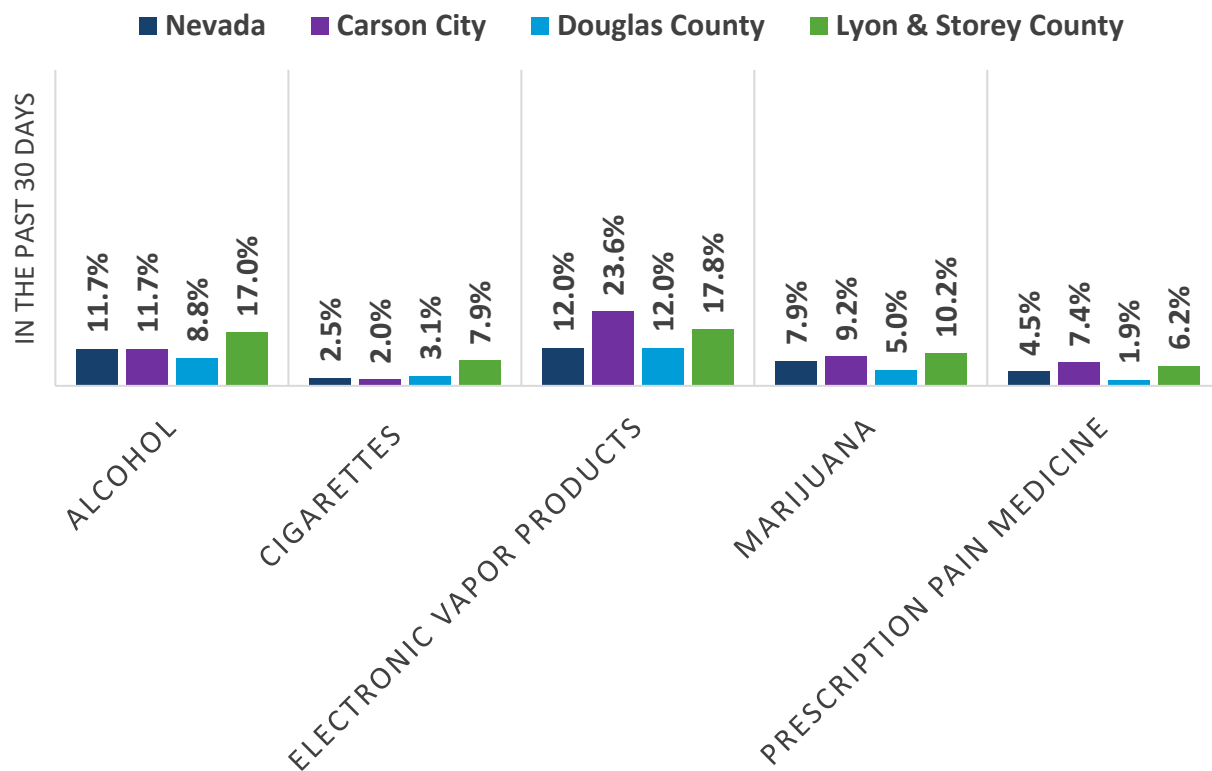

GRADES 6 TO 8	Nevada	Carson City	Douglas County	Lyon & Storey County
Alcohol	11.7%	11.7%	8.8%	17.0%
Cigarettes	2.5%	2.0%	3.1%	7.9%
Electronic Vapor Products	12.0%	23.6%	12.0%	17.8%
Marijuana	7.9%	9.2%	5.0%	10.2%
Prescription Pain Medicine	4.5%	7.4%	1.9%	6.2%

Source: State of Nevada, Division of Public and Behavioral Health and the University of Nevada, Reno. 2019 Nevada Middle School Youth Risk Behavior Survey Report

- Statewide, electronic vapor products were reported to be among the most the popular substance middle school students are currently using (12.0%).

### Alcohol and Tobacco Use

The COVID-19 pandemic has had a profound impact on alcohol use nationwide and is expected to contribute to 8,000 additional deaths from alcohol-related liver disease, 18,700 cases of liver failure, and 1,000 cases of liver cancer by 2040.<sup>132</sup>

Nearly a quarter of Douglas County adults reported binge or heavy drinking in the past 30 days, the highest age-adjusted rate within the service area. Over one in five adults reported binge or heavy drinking in Carson City and Storey County.

**About the Data**

The Behavioral Risk Factor Surveillance Survey defines binge drinking as adults (>18) who reported having five or more drinks (men) or four or more drinks (women) on an occasion in the past 30 days.

**Exhibit 200: Adult Self-Reported Alcohol Use**

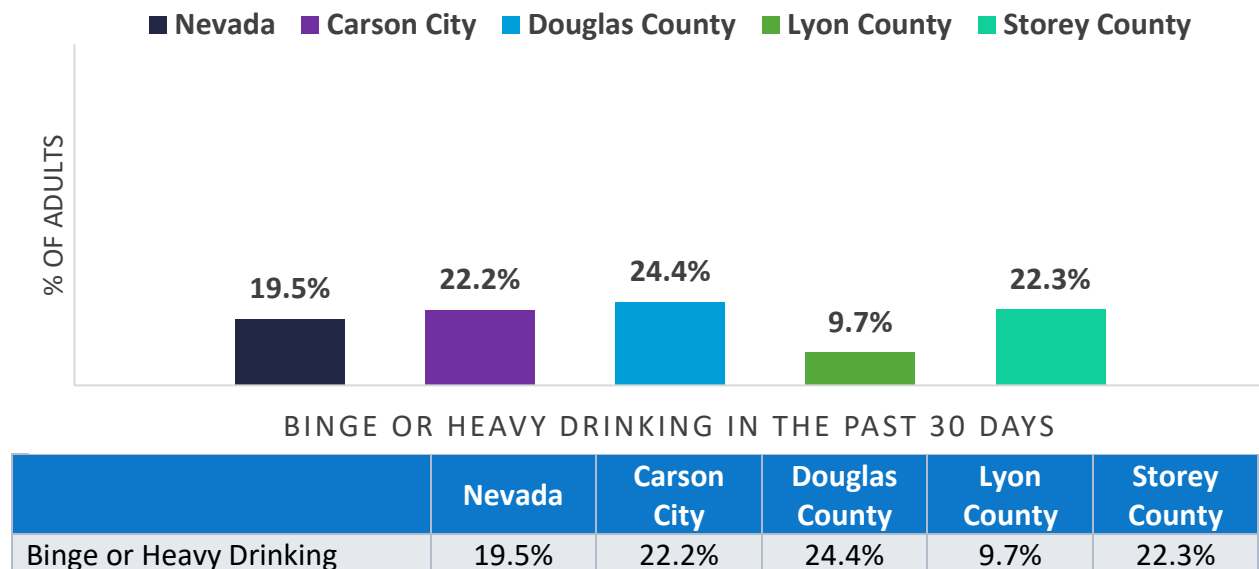

Source: State of Nevada, Division of Public and Behavioral Health and the University of Nevada, Reno. 2019 Nevada High School Youth Risk Behavior Survey Report

Alcohol-impaired driving deaths is the percentage of motor vehicle crash deaths with alcohol involvement. Over 40.0% of motor vehicle crash deaths in Lyon County involved alcohol, the highest within the Quad-County Region.

<sup>132</sup> The Harvard Gazette. Study holds warning on pandemic drinking, 2022.  
 Link: [news.harvard.edu/gazette/story/2022/01/covid-related-drinking-linked-to-rise-in-liver-disease/](https://news.harvard.edu/gazette/story/2022/01/covid-related-drinking-linked-to-rise-in-liver-disease/)

**Exhibit 201: Alcohol-related Vehicle Fatalities**

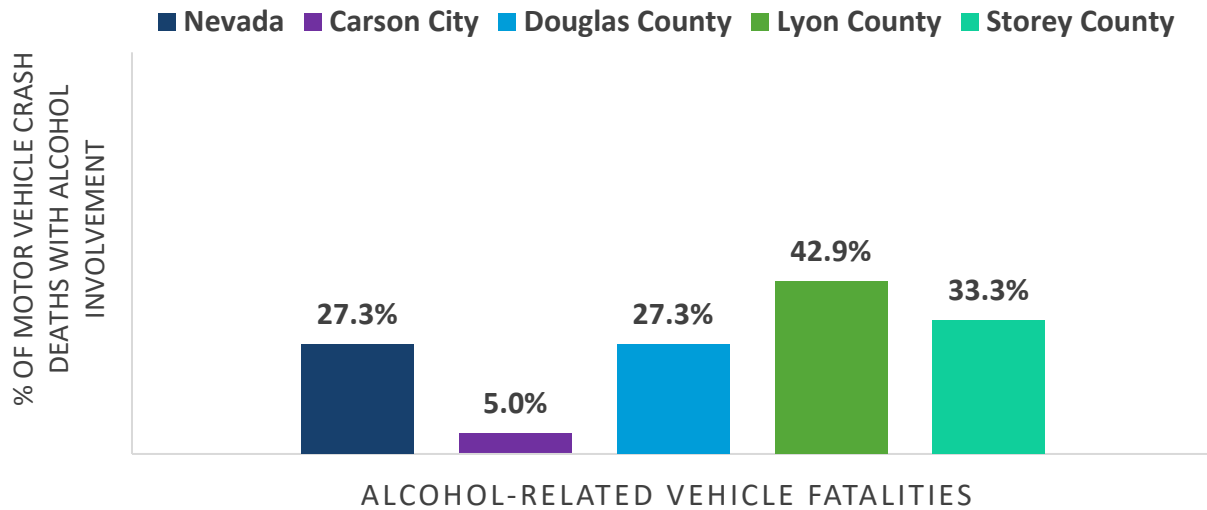

Nevada	Carson City	Douglas County	Lyon County	Storey County
27.3%	5.0%	27.3%	42.9%	33.3%

Source: United States Department of Transportation. National Highway Traffic Safety Administration. 2016-2020 Fatality Analysis Reporting

Between 2017 and 2019, Carson City experienced the most alcohol-related deaths per 100,000 population, a rate twice as high than Nevada and Storey County.

**Exhibit 202: Alcohol-related Mortality Rate**

Per 100,000 Population	Nevada	Carson City	Douglas County	Lyon County	Storey County
2017-2019	36.6	89.4	53.1	46.1	31.6

Source: State of Nevada Department of Health & Human Services Office of Analytics. 2021 Nevada Health Profiles

**Exhibit 203: Adult Tobacco Use<sup>133</sup>**

Nevada	Carson City	Douglas County	Lyon County	Storey County
15.8%	17.4%	16.2%	20.6%	16.3%

Source: National Center for Chronic Disease Prevention and Health Promotion, Division of Population Health. Behavioral Risk Factor Surveillance System, 2019

Nearly three in ten high school students in the Quad-County Region self-reported current alcohol use and nearly one in five high school students across the service area self-reported current binge drinking.

<sup>133</sup> Respondents aged ≥18 years who report having smoked ≥100 cigarettes in their lifetime and currently smoke every day or some days.

**Exhibit 204: High School Student Self-Reported Current Alcohol Use**

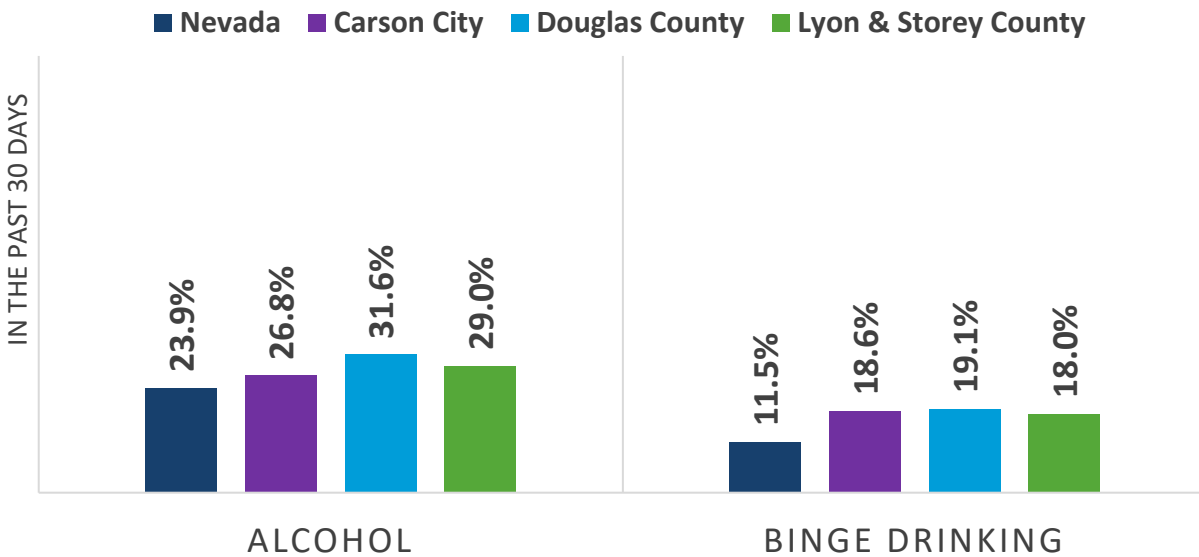

Source: State of Nevada, Division of Public and Behavioral Health and the University of Nevada, Reno. 2019 Nevada High School Youth Risk Behavior Survey Report

**Exhibit 205: High School Student Self-Reported Current Tobacco Use**

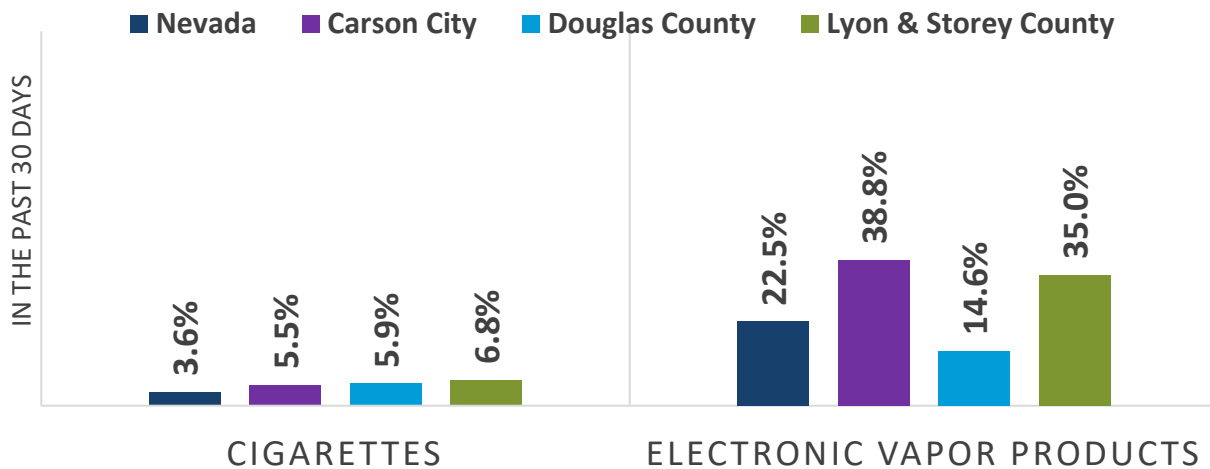

National Center for Chronic Disease Prevention and Health Promotion, Division of Population Health. Youth Behavioral Risk Factor Surveillance System, 2019

- Electronic vapor products have become one of the most popular substance to use among youth. Over 30.0% of high school students in Carson City and Storey County reported current vape use.



## QUAD-COUNTY REGIONAL COMMUNITY HEALTH NEEDS ASSESSMENT

Perception of access refers to the percentage of high school students who reported that it would be ‘very easy’ to get select substances if they wanted some. Over one-third of high school students in the service area reported that alcohol would be “very easy” to obtain.

**Exhibit 206: High School Students Self-Reported Perception of Access<sup>134</sup>**

GRADES 9 TO 12	Nevada	Carson City	Douglas County	Lyon & Storey County
Cigarettes	20.4%	27.6%	30.3%	27.2%
Electronic Vapor Products	34.5%	48.9%	53.3%	44.5%
Alcohol	30.4%	32.9%	35.7%	30.1%
Marijuana	39.9%	32.5%	34.3%	25.7%
Prescription Pain Medicine	11.1%	13.4%	15.2%	9.0%

Source: State of Nevada, Division of Public and Behavioral Health and the University of Nevada, Reno. 2019 Nevada High School Youth Risk Behavior Survey Report

- Approximately half of all high school students in Carson City and Douglas County reported that electronic vapor products would be “very easy” to get.
- Approximately one in four high school students in Lyon and Storey Counties reported marijuana as being “very easy” to get, while over one in three students in Carson City and Douglas County reported the same.
- Over 15.0% of high school students in Douglas County reported that prescription pain medicine is “very easy” to get. Rates are slightly lower in the surrounding service area.

<sup>134</sup> Percentage of high school students who thought it would be very easy to get specific substances if they wanted some.

## Behavioral Health Workforce

Health professional shortages have long impeded behavioral healthcare access and are largely attributable to low reimbursement or provider payment, as well as the recent and imminent retirement of more than half of the current workforce.<sup>135</sup>

Although workforce data been confirmed to reflect the most up-to-date numbers and rates available, the following limitations are critical to understanding the “full picture” of the behavioral healthcare workforce in each of the Quad-County Region.

### Data Limitations:

- Data on licensed active healthcare provider is collected **by billing address only**.
- Current collection methods **do not** collect data on race/ethnicity, sub-specialty (if applicable), or part-time or full-time status of healthcare providers.
- Numbers and/or rates may reflect providers that may work in one geographical area, **but travel to other counties periodically**.

*For example, if a dentist from Carson City provides services to Storey County every Wednesday, the current data collecting methodology may count that as a standing provider in Storey County.*

Lyon County has one local psychiatrists (MD or DO), while Carson City only has five and Douglas County has two. Overall, there are a greater number of psychologists than psychiatrists in the Quad-County service area.

### About the Data

Rates of healthcare providers are per 100,000 population unless specified.

### Exhibit 207: Psychiatrists & Psychologists

	United States		Nevada		Carson City		Douglas County		Lyon County		Storey County	
	Rate	#	Rate	#	Rate	#	Rate	#	Rate	#	Rate	#
Psychiatrists	ND	ND	9.3	300	8.7	5	3.6	2	1.7	1	0.0	0
Psychologists	ND	ND	14.5	459	44.3	25	12.0	6	3.5	2	0.0	0

Source: University of Nevada, Reno School of Medicine’s Office of Statewide Initiatives, Nevada Instant Atlas. Nevada Board of Psychological Examiners, Board of Osteopathic Medicine, 2022

<sup>135</sup> American Hospital Association. Trend Watch: The impacts of the COVID-19 pandemic on behavioral health, 2022. Link: [aha.org/system/files/media/file/2022/05/trendwatch-the-impacts-of-the-covid-19-pandemic-on-behavioral-health.pdf](https://www.aha.org/system/files/media/file/2022/05/trendwatch-the-impacts-of-the-covid-19-pandemic-on-behavioral-health.pdf)

## QUAD-COUNTY REGIONAL COMMUNITY HEALTH NEEDS ASSESSMENT

The table below is subject to the data limitations listed at outset of this section. This sourcebook lists that there are zero Clinical Professional Counselors in Storey County, but there is multiple as of September 2022.

### Exhibit 208: Social Workers and Clinical Professional Counselors

	United States		Nevada		Carson City		Douglas County		Lyon County		Storey County	
	Rate	#	Rate	#	Rate	#	Rate	#	Rate	#	Rate	#
Social Workers	ND	ND	35.1	1,354	49.8	33	40.1	25	26.0	22	45.7	

Source: University of Nevada, Reno School of Medicine's Office of Statewide Initiatives, Nevada Instant Atlas. State of Nevada Board of Examiners for Social Workers, 2022

### Exhibit 209: Clinical Professional Counselors

	United States		Nevada		Carson City		Douglas County		Lyon County		Storey County	
	Rate	#	Rate	#	Rate	#	Rate	#	Rate	#	Rate	#
Clinical Professional Counselors	ND	ND	10.8	326	3.5	2	12.0	6	6.9	4	0.0	0

Source: University of Nevada, Reno School of Medicine's Office of Statewide Initiatives, Nevada Instant Atlas. State of Nevada Board of Examiners for Marriage and Family Therapists and Clinical Professional Counselors, 2020.

### Exhibit 210: Marriage & Family Therapists

United States		Nevada		Carson City		Douglas County		Lyon County		Storey County	
Rate	#	Rate	#	Rate	#	Rate	#	Rate	#	Rate	#
22.1	ND	28.4	898	47.9	27	40.1	20	17.3	10	22.9	1

Source: University of Nevada, Reno School of Medicine's Office of Statewide Initiatives, Nevada Instant Atlas. State of Nevada Board of Examiners for Marriage, Family Therapists and Clinical Professional Counselors, 2022.

### Exhibit 211: Alcohol, Drug & Gambling Counselors

United States		Nevada		Carson City		Douglas County		Lyon County		Storey County	
Rate	#	Rate	#	Rate	#	Rate	#	Rate	#	Rate	#
ND	ND	24.4	791	60.3	35	31.9	16	35.1	22	22.0	1

Source: University of Nevada Reno, School of Medicine Office of Statewide Initiatives. Nevada State Board for Alcohol, Drug and Gambling Counselors, 2022.

## Behavioral Health Facilities

There are 16 rural community mental health centers through Nevada, acting as the state mental health authority. An array of services are offered which include outpatient services, case management, Rehabilitative Mental Health (RMH) services, peer support services, residential support, counseling, medication clinic, mobile crisis response team for children, Immediate Mental Healthcare Team for adults, Mental Health Court Forensic Assessment and Triage Team (FASTT), Mobile Outreach Safety Team (MOST), and Juvenile Justice Assessment and Screening Triage Team (JJASTT).<sup>136</sup>

### Exhibit 212: Mental Health Treatment Facilities Within the Quad-County Region



Source: PolicyMap. Substance Abuse and Mental Health Services Administration, 2019

<sup>136</sup> Department of Health and Human Services Nevada Division of Public and Behavioral Health, Rural Clinics Administration. Link: [dphh.nv.gov/Programs/Rural\\_Clinics\\_Administration/Rural\\_Clinics\\_Admin/](http://dphh.nv.gov/Programs/Rural_Clinics_Administration/Rural_Clinics_Admin/)

# QUAD-COUNTY REGIONAL COMMUNITY HEALTH NEEDS ASSESSMENT

The Quad-County Region has a number of substance use disorder treatment facilities within the area, predominantly in central Carson City.

### Exhibit 213: Substance Use Disorder Treatment Facilities



▼ Drug and Alcohol Treatment Facilities



*Lyon County*



*Douglas County*



*Storey County*

Source: PolicyMap (Drug and Alcohol Treatment Facilities)  
Substance Abuse and Mental Health Services Administration, 2019

## QUAD-COUNTY REGIONAL COMMUNITY HEALTH NEEDS ASSESSMENT

The monthly averages indicate that the number of adults waiting for in emergency rooms for behavioral health services have been steadily increasing since January 2022, further highlighting the need for access to existing and additional behavioral health services.

*“Access can be difficult to measure, especially when recent data reflects utilization during the COVID-19 pandemic restrictions. Treatment in Nevada’s facilities specializing in Substance Use Disorder fell by 31% between 2019 and 2020, likely due to COVID-19 restrictions.”*

*Nevada Resiliency Fund:*

**Exhibit 214: Individuals Waiting in Emergency Rooms for Behavioral Health Services**

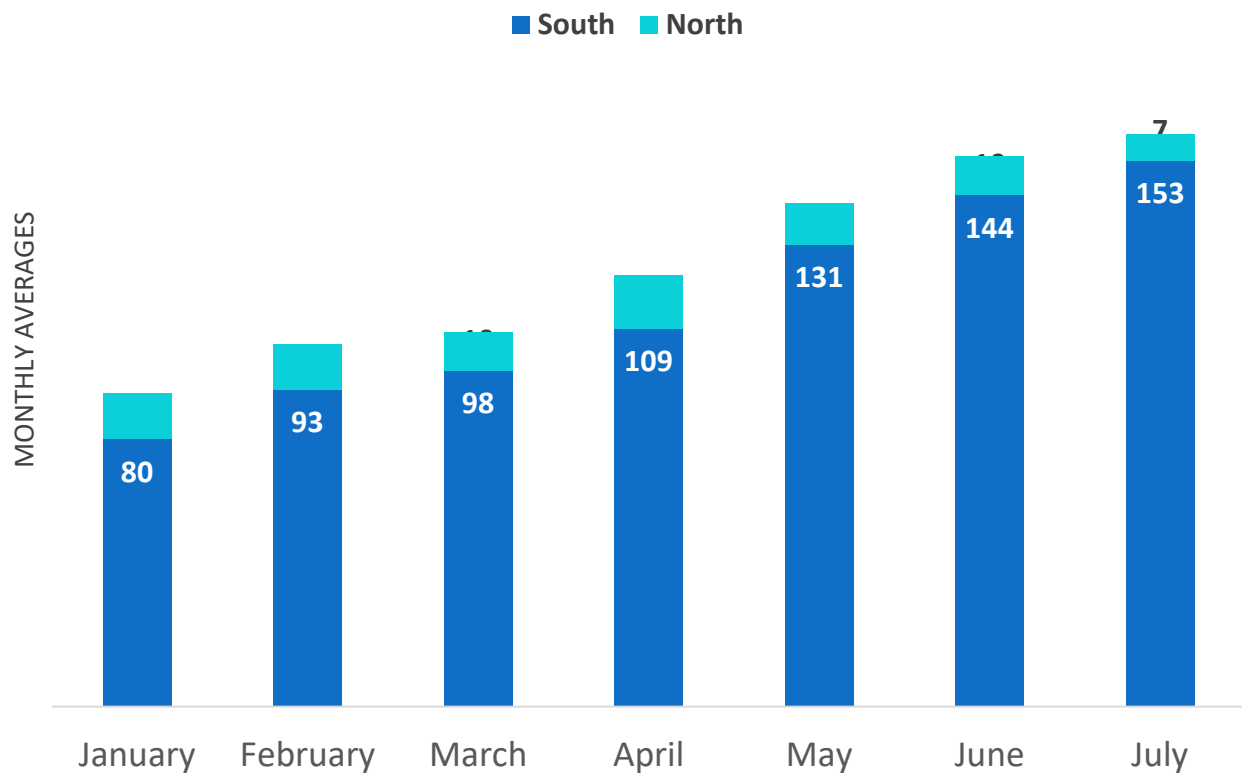

Source: State of Nevada Department of Health & Human Services, Office of Analytics. Behavioral Health Chart Park, Data as of August 30, 2022

## The Opioid Epidemic

Between 2019 and 2020, Nevada experienced a 55.0% increase in drug-related overdose deaths with overdose deaths attributable to opioids increasing by 76.0%. In 2020, 788 drug-related overdose deaths occurred. Of those deaths, 65.2% were attributable to opioids.<sup>137</sup>

Between 2019 and 2020, the opioid-related overdose death rate increased in three out of four service area counties, with Carson City alone reporting a decrease. Douglas County experienced the most severe increase from 5.1 deaths to 18.1 deaths per 100,000 population.

### About the Data

Data include accidental poisonings, intentional self-poisonings, and assault by drug poisonings, and drug poisoning of undetermined intent for drug-related overdose deaths and where any of the following opioid-related substances contributed to the cause of death: opium, heroin, natural and semi-synthetic opioids, methadone, synthetic opioids, and other/unspecified opioids.

### Exhibit 215: Opioid-Related Overdose Deaths

	Nevada		Carson City		Douglas County		Lyon County		Storey County	
	2019	2020	2019	2020	2019	2020	2019	2020	2019	2020
Per 100,000 Population	292	514	16.0	8.8	5.1	18.1	21.1	12.1	-	-

Source: Nevada Resiliency Fund: Opioid Needs Assessment, 2022

### Exhibit 216: Opioid-Related Overdose Deaths Year to Year Percent Change

	Nevada	Carson City	Douglas County	Lyon County	Storey County
2019-2020 Percent Change	55.0%	-7.2%	13.0%	9.0%	-

Source: Nevada Resiliency Fund: Opioid Needs Assessment, 2022

- Storey County shows no data as a result of the rate being zero or too low to report, although the data suggests, “one can infer the rates have significantly increased.”<sup>138</sup>

<sup>137</sup> Nevada Department of Health & Human Services, Nevada State Unintentional Drug Overdose Reporting System: Report of Deaths 2019 to 2020 – Statewide 2020. Link: [nvopioidresponse.org/wp-content/uploads/2019/05/sudors\\_report\\_2019\\_2020.pdf](https://nvopioidresponse.org/wp-content/uploads/2019/05/sudors_report_2019_2020.pdf)

<sup>138</sup> Nevada Resiliency Fund: Opioid Needs Assessment, 2022. Link: [dhhs.nv.gov/uploadedFiles/dhhsnv.gov/content/Programs/Grants/Advisory\\_Committees/ACRN/NV\\_Needs%20Assessment%20Report%20DRAFT%20for%20ACRN%202022%2004%2009\(2\).pdf](https://dhhs.nv.gov/uploadedFiles/dhhsnv.gov/content/Programs/Grants/Advisory_Committees/ACRN/NV_Needs%20Assessment%20Report%20DRAFT%20for%20ACRN%202022%2004%2009(2).pdf)

## QUAD-COUNTY REGIONAL COMMUNITY HEALTH NEEDS ASSESSMENT

In 2020, Carson City had the highest rate of opioid dispensing at 95.9 per 100 people, over two times the national rate. Carson City’s rate was almost high enough for each person in the county to have an opioid prescription.<sup>139</sup>

*“Between 2019 and 2020, Nevada saw a significant increase in fentanyl use by 227% and opioid-related emergency department encounters also increased by 26%. Nevada also experienced a sharp increase in polysubstance overdoses and illicit pill consumption.”*

*Nevada Resiliency Fund: Opioid Needs Assessment, 2022*

### Exhibit 217: Rate of Opioid Prescriptions<sup>140</sup>

United States	Nevada	Carson City	Douglas County	Lyon County	Storey County
43.3	47.4	95.9	43.2	10.2	29.9

Source: Nevada Resiliency Fund: Opioid Needs Assessment, 2022

<sup>139</sup> Nevada Resiliency Fund: Opioid Needs Assessment, 2022. Link: [dhhs.nv.gov/uploadedFiles/dhhsnv.gov/content/Programs/Grants/Advisory\\_Committees/ACRN/NV\\_Needs%20Assessment%20Report%20DRAFT%20for%20ACRN%202022%2004%2009\(2\).pdf](https://dhhs.nv.gov/uploadedFiles/dhhsnv.gov/content/Programs/Grants/Advisory_Committees/ACRN/NV_Needs%20Assessment%20Report%20DRAFT%20for%20ACRN%202022%2004%2009(2).pdf)

<sup>140</sup> Number of pharmacies that account for nearly 92% of retail prescriptions in the United States. Includes new and refill prescriptions. Opioid prescriptions, including buprenorphine, codeine, fentanyl, hydrocodone, hydromorphone, methadone, morphine, oxycodone, oxymorphone, propoxyphene, tapentadol, and tramadol.



## LGBTQIA + Youth

The LGBTQIA + community have significantly higher percent of depressive disorder diagnoses and more days of poor mental health.<sup>141</sup>

In Nevada, gay, lesbian, and/or bisexual students were twice as more likely to be bullied on school property according to the 2019 Youth Behavioral Risk Factor Surveillance System.

Research has shown that all forms of bullying are significantly associated with increases in suicidal ideation. This is important to note as the COVID-19 pandemic greatly increased the amount of time youth spent and continue to

spend on social media and other social platforms.<sup>142</sup> Electronic bullying includes being bullied through texting, Instagram, Facebook, or other social media, during the 12 months before the survey.

According to The Trevor Project's 2021 National Survey on LGBTQ Youth Mental Health, which collected data between October and December of 2020 and had 34,759 LGBTQ youth respondents, the majority of LGBTQ youth (52%) who were enrolled in middle or high school reported being bullied in the past year, and LGBTQ students who reported being bullied in the past year had three times great odds of attempting suicide in the past year. However, transgender and nonbinary youth who reported having pronouns respected by all of the people they lived with attempted suicide at half the rate of those who did not have their pronouns respected by anyone with whom they lived.<sup>143</sup>

The same study found that 75% of LGBTQ youth reported that they had experienced discrimination based on their sexual orientation or gender identity at least once in their lifetime. The Trevor Project is the world's largest suicide prevention and crisis intervention organization for LGBTQ young people.

*"LGBTQIA + youth are nearly twice as likely to be called names, verbally harassed or physically assaulted at school compared to their non-LGBT peers. Their mental health and education, not to mention their physical well-being, are at-risk"*

*Mental Health America*

<sup>141</sup> Nevada SAPTA EPI Profile, 2019. Link:

[dhhs.nv.gov/uploadedFiles/dhhsnv.gov/content/Programs/Office\\_of\\_Analytics/SAPTA\\_EPI\\_Profile\\_Nevada\\_2019.pdf](https://dhhs.nv.gov/uploadedFiles/dhhsnv.gov/content/Programs/Office_of_Analytics/SAPTA_EPI_Profile_Nevada_2019.pdf)

<sup>142</sup> National Institutes of Health. Cyberbullying linked with suicidal thoughts and attempts in young adolescents, 2022.

<sup>143</sup> The Trevor Project National Survey on LGBTQ Youth Mental Health 2021. Link: <https://www.thetrevorproject.org/survey-2021/?section=Introduction>

Exhibit 218: Student Self-Reported Sexual Identity

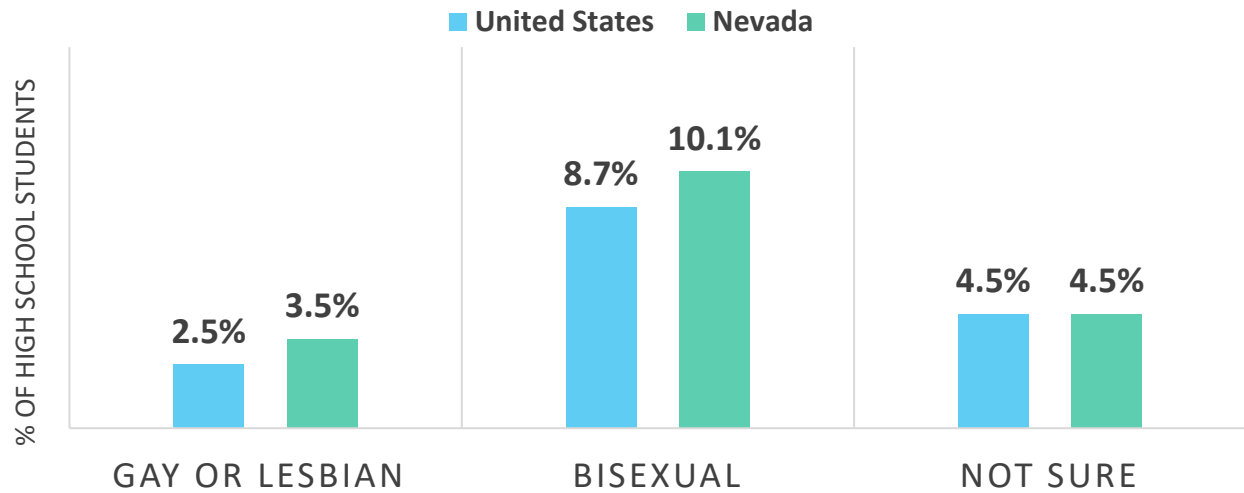

	United States	Nevada
Gay or Lesbian	2.5%	3.5%
Bisexual	8.7%	10.1%
Not Sure	4.5%	4.5%

Source: National Center for HIV, Viral Hepatitis, STD, and TB Prevention. Division of Adolescent & School Health, 2021

More students who identify as gay, lesbian, or bisexual reported feeling sad or hopeless almost every day for two or more weeks in a row so that they stopped doing some usual activities, during the 12 months before the 2019 survey.

It is important to note that data for this survey was collected in 2019, prior to the COVID-19 pandemic. Figures are expected to increase as high school students experienced isolation and higher levels of depression and anxiety since spring of 2020.

Exhibit 219: Felt Sad Or Hopeless in the Past Year

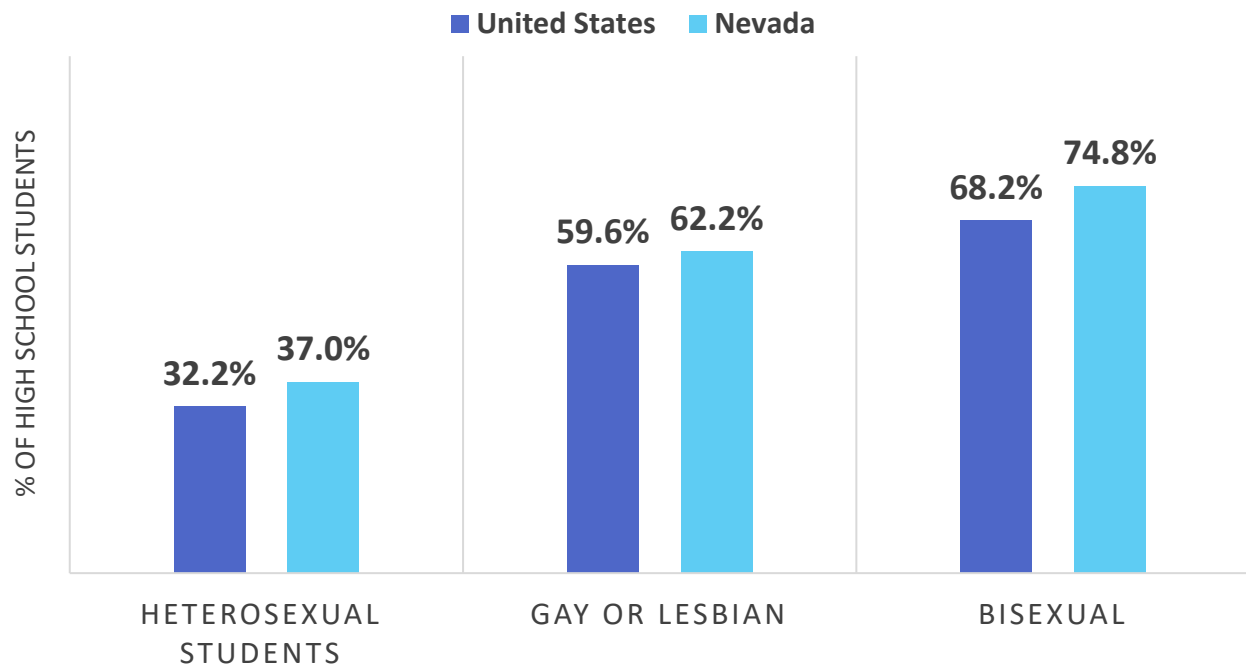

	United States	Nevada
Heterosexual Students	32.2%	37.0%
Gay or Lesbian	59.6%	62.2%
Bisexual	68.2%	74.8%

Source: State of Nevada, Division of Public and Behavioral Health and the University of Nevada, Reno. 2019 Nevada High School Youth Risk Behavior Survey Report

## Appendices

Appendix A: Carson Tahoe Health IRS Form 990, Schedule H

Appendix B: Carson Tahoe Health Progress Since 2019 CHNA

Appendix C: Secondary Population Data Sources

Appendix D: Stakeholder Interview Guide

Appendix E: Focus Group Discussion Moderator's Guide

Appendix F: Telephone Survey Templates

Appendix G: Community Survey Templates

Appendix H: Access Audit

Appendix I: Additional Community Survey Prioritization Tables

Appendix J: Additional Needs Prioritization Process and Results

Appendix K: Community Resource Guide

## Appendix A: Carson Tahoe Health IRS Form 990, Schedule H

Carson Tahoe Health made copies of past CHNAs (2019, 2016, and 2013) available through their website and in paper copy, and invited community comment. No comments were received from the public for the 2019 CHNA.

For non-profit hospitals, a Community Health Needs Assessment (CHNA) also serves to satisfy certain requirements of tax reporting, pursuant to provisions of the Patient Protection & Affordable Care Act of 2010. To understand which elements of this report relate to those requested as part of hospitals’ reporting on IRS Schedule H (Form 990), the following table cross-references related sections:

IRS Form 990, Schedule H	See Report Page
Part V Section B Line 3a <b>A definition of the community served by the hospital facility</b>	p. 12
Part V Section B Line 3b <b>Demographics of the community</b>	pp. 12-22
Part V Section B Line 3c <b>Existing healthcare facilities and resources within the community that are available to respond to the health needs of the community</b>	pp. 157-158; 208-210; Appendix K
Part V Section B Line 3d <b>How data was obtained</b>	pp. 10-11; 40-41; 66; 96; Appendices C and H
Part V Section B Line 3e <b>The significant health needs of the community</b>	pp. 24-39 and throughout
Part V Section B Line 3f <b>Primary and chronic disease needs and other health issues of uninsured persons, low-income persons, and minority groups</b>	Addressed throughout across all data collection modes (including qualitative, quantitative survey, and secondary data research)
Part V Section B Line 3g <b>The process for identifying and prioritizing community health needs and services to meet the community health needs</b>	pp. 10-11; 23-24; Appendix J
Part V Section B Line 3h <b>The process for consulting with persons representing the community’s interests</b>	pp. 2; 8-9; 40-41
Part V Section B Line 3i <b>The impact of any actions taken to address the significant health needs identified in the hospital facility’s prior CHNA(s)</b>	Appendix B

## Appendix B: Carson Tahoe Health Progress Since 2019 CHNA

Impact & Progress on Community Health Needs since 2019 CHNA

Prioritized list of community health needs:

1. Mental Health
2. Access to Healthcare
3. Diabetes
4. Heart Disease & Stroke
5. Substance Abuse
6. Nutrition, Physical Activity & Weight
7. Cancer
8. COVID-19 Response

Carson Tahoe Health Progress on 2019 CHNA Priorities			
Mental Health & Substance Abuse			
Strategy	Action	Measurement/Additional Information	Partner
Expand Mallory Behavioral Health Crisis Center	<ul style="list-style-type: none"> <li>• Expand capacity and ability to welcome public walk-ins</li> </ul>	<ul style="list-style-type: none"> <li>• Expanded unit to 15 beds</li> <li>• Added waiting room and observation area</li> </ul>	First responders; Regional Sheriff Depts. & Jail
Partner with school districts to identify and support students with mental health challenges	<ul style="list-style-type: none"> <li>• Continue suicide risk assessments for Carson City</li> <li>• Expand to Douglas County</li> </ul>	796 assessments completed 2019-2021	Carson City and Douglas County School Districts
Engage community in suicide prevention education and Crisis Intervention Training	<ul style="list-style-type: none"> <li>• Train staff and community to support suicide prevention and suicide-safer care</li> <li>• Support schools and Partnership Carson City with delivering Signs of Suicide (SOS) trainings</li> </ul>	<ul style="list-style-type: none"> <li>• Trained Behavioral Health Services staff to teach SafeTALK and Mental Health First Aid and offered to community</li> <li>• Offered Crisis Intervention Training at Sheriffs Departments</li> <li>• Launched Zero Suicide statewide</li> </ul>	Local schools, churches, and Sheriff's Departments, Partnership Carson City

QUAD-COUNTY REGIONAL COMMUNITY HEALTH NEEDS ASSESSMENT

Carson Tahoe Health Progress on 2019 CHNA Priorities			
		initiative at Behavioral Health Services	
Continue/Develop community-based mental health programs	<ul style="list-style-type: none"> <li>• Continue First Episode Psychosis (FEP) program</li> <li>• Continue Hospital Diversion Assertive Community Treatment (ACT)</li> <li>• Pilot Early Diversion Assertive Community Treatment (ACT)</li> </ul>	CTH has two Assertive Community Treatment (ACT) programs serving SMI and/or Co-Occurring Disorders: (1) Hospital Diversion ACT provides treatment and rehabilitation to clients with chronic, severe mental illness. (2) Early Diversion ACT aims to reduce an individual’s risk for law enforcement interactions or potential arrests.	
Increase community awareness of behavioral health challenges and the organizations addressing challenges	Participate in community events to educate, spread awareness and reduce stigma with the goal to build healthy and helpful partnerships with community resources.	Sponsored 12 events and participated regularly in health fairs, walks, and events including Nevada’s Recovery and Prevention 5K, Sheriff’s Night Out, Senior Celebration, and more	Suicide Prevention Network, NAMI, Alzheimer’s Association, Northern Nevada RAVE, China Springs Youth Camp, Nevada Recovery and Prevention
Advocate at the legislature for increased access to mental health services	<ul style="list-style-type: none"> <li>• Wrote letters, met with legislators, and testified in support of SB 156 and SB 390</li> </ul>	Bills SB 156 and SB 390 both passed. SB 156 expands sustainability for crisis stabilization services. SB 390	Regional health and human service agencies, not-for-profits, NAMI

QUAD-COUNTY REGIONAL COMMUNITY HEALTH NEEDS ASSESSMENT

Carson Tahoe Health Progress on 2019 CHNA Priorities			
	<ul style="list-style-type: none"> <li>Hospital participation on Northern Region Behavioral Health Policy Board</li> </ul>	established a 988 mental health crisis call-line and sustainable funding for the call line.	
Participate in regional mental health collaboratives	<ul style="list-style-type: none"> <li>Continue Community Coalition workgroup at CTH and participate in regional collaboratives</li> </ul>	CTH participates in regional meetings and workgroups: <ul style="list-style-type: none"> <li>National Alliance on Mental Illness (NAMI) Western Nevada</li> <li>Nevada Coalition for Suicide Prevention</li> <li>Carson City Community Coalition</li> <li>Carson City Partnership</li> <li>Carson City Behavioral Health Taskforce</li> <li>Senior Service Network</li> <li>Douglas County Partnership</li> <li>Mobile Outreach Safety Team (MOST) – all Counties</li> <li>Nevada Office of Suicide Prevention</li> <li>Northern Regional Behavioral Health Policy Board</li> </ul>	CCHHS EMS & Fire, Sheriff’s Office, State of Nevada, Regional not-for-profits
Invest in the expansion of community mental health services	<ul style="list-style-type: none"> <li>Financially support local organizations expanding services to youth, families, and veterans</li> </ul>	\$102,500 granted from Community Partnership Fund in support of mental health programming	Ron Wood Family Resource Center; Veteran’s Healing Camp
Access to Healthcare			
Strategy	Action	Measurement/Additional Information	Partner
Expand local access to specialty care	<ul style="list-style-type: none"> <li>Recruit Neurosurgeon</li> </ul>	<ul style="list-style-type: none"> <li>Rajamand, Sina DO - Neurological Surgery</li> </ul>	



QUAD-COUNTY REGIONAL COMMUNITY HEALTH NEEDS ASSESSMENT

Carson Tahoe Health Progress on 2019 CHNA Priorities			
Expand local access to specialty care	<ul style="list-style-type: none"> <li>Recruit Electrophysiologist (Dr. Turner)</li> </ul>	<ul style="list-style-type: none"> <li>Evaluations for 114 new patients in 2021</li> </ul>	
Expand Telehealth Services	<ul style="list-style-type: none"> <li>Establish specialty telehealth network</li> </ul>	<ul style="list-style-type: none"> <li>22,906 total visits over 2019, 2020, and 2021.</li> </ul>	Specialty providers
Improve health of patients through Primary Care continual improvement	<ul style="list-style-type: none"> <li>Monitor and improve upon patient wellness and outcomes measures</li> </ul>	<ul style="list-style-type: none"> <li>CTMG 90<sup>th</sup> percentile in diabetic A1c scores under 9% and &gt;90<sup>th</sup> percentile in controlling blood pressure on hypertension patients with BP &lt; 139/89</li> </ul>	Silver State ACO
Expand local access to specialty care	<ul style="list-style-type: none"> <li>Recruit Cardiologists to CTMG</li> </ul>	<ul style="list-style-type: none"> <li>De Schutter, Alban MD - Cardiovascular Disease</li> <li>Turner, Jeffrey DO - Cardiovascular Disease</li> <li>Toft, Lorrel Elizabeth Brown MD - Cardiovascular Disease</li> </ul>	Carson Tahoe Medical Group
Expand local access to primary care	<ul style="list-style-type: none"> <li>Recruit PCPs to service area</li> </ul>	<ul style="list-style-type: none"> <li>Butler, Anne MD - Internal Medicine</li> <li>Gordon, Matthew MD Family Medicine</li> <li>Martin, Sherry APRN Nurse Practitioner</li> <li>Sarmad, Shervin MD Internal Medicine</li> <li>Hoskins, David MD Family Medicine</li> <li>Brewer, Cyndi PA-C Physician Assistant</li> <li>Douglas, Sara APRN Nurse Practitioner</li> <li>Janas, Jessica APRN Nurse Practitioner</li> </ul>	Carson Tahoe Medical Group, Carson Medical Group

QUAD-COUNTY REGIONAL COMMUNITY HEALTH NEEDS ASSESSMENT

Carson Tahoe Health Progress on 2019 CHNA Priorities			
		<ul style="list-style-type: none"> <li>Swearngin, Stephan DO Family Medicine</li> <li>Starr, Alana APRN Nurse Practitioner</li> </ul>	
Continue Services at Wal-Mart Retail Clinics	<ul style="list-style-type: none"> <li>Maintain presence in local Wal-Marts</li> </ul>	Patient volumes: 2019: 10,345 2020: 4,797 2021: 6,619	
Continue Patient Support Classes	<ul style="list-style-type: none"> <li>Total Joint Class</li> </ul>	# of participants in pre-surgical Total Joint Education Class: 2020: 200 2021: 500	Carson Tahoe Physical Therapy
Invest in the expansion of community health access	<ul style="list-style-type: none"> <li>Financially support local organizations expanding services</li> </ul>	\$140,000 pledged from Community Partnership Fund in support of access to care	Nevada Urban Indians; Nevada Rural Counties RSVP
Diabetes			
Strategy	Action	Measurement/Additional Information	Partner
Develop Diabetes Services	Increase volumes for Diabetes Education and expand FREE services offered.	2019: Group Class - 72 Total Visits - 415 2020: No group class due to COVID-19 restrictions. Total Visits – 310 Total visits lower due to COVID-19 pandemic. 2021: Group Class - 38 Total Visits - 371	Center for Health Promotion

QUAD-COUNTY REGIONAL COMMUNITY HEALTH NEEDS ASSESSMENT

Carson Tahoe Health Progress on 2019 CHNA Priorities			
Promote Center for Wound Healing	Increase volumes through physician referral and health fair participations	2019: under different management (Healogics, Melinda Laidlaw) 2020: promotion halted due to COVID-19 2021: RN participation in health fairs, X3	N/A  N/A  Various
Heart Disease & Stroke			
Strategy	Action	Measurement/Additional Information	Partner
Attain Primary Chest Pain Center designation through American College of Cardiology	<ul style="list-style-type: none"> <li>Establish multidisciplinary team to address all component areas including goal setting, tracking, and community outreach</li> </ul>	<ul style="list-style-type: none"> <li>Achieved designation in recognition of continuous improvement efforts to improve heart health of our community</li> </ul>	American College of Cardiology
Improve quality of care and outcomes for Congestive Heart Failure patients	<ul style="list-style-type: none"> <li>Reduce patient mortality and readmission within 30 days by establishing clinic and quick access for discharging CHF patients</li> </ul>	Heart Failure Mortality Rate (Goal for 2022 <9.23%): 2019: 6.8% 2020: 3.64% 2021: 3.55% 30 Day Readmission Heart Failure (Goal for 2022 <16.9%): 2019: 18.03% 2020: 15.24% 2021: 13.76%	CTMG CHF Clinic
Expand Low Cost Heart Smart Screenings	<ul style="list-style-type: none"> <li>Add Dayton as a screening site</li> <li>Continue screenings in Carson City, Minden, and S. Reno</li> </ul>	2019: Offered in February and September of 2019 Dayton X2 – 27, 24 Minden X4 – 46, 38, 47, 50 Carson X4 – 51, 48, 49, 46	CTMG Cardiology

QUAD-COUNTY REGIONAL COMMUNITY HEALTH NEEDS ASSESSMENT

Carson Tahoe Health Progress on 2019 CHNA Priorities			
		<p>2020: Offered in September only due to COVID-19. Minden X 1 - 31 Carson City X2 – 31, 33 2021: Offered in April and September 2021. Carson X4 – 158 Minden X4 - 102</p>	
Continue Cardiac Rehab Program	<ul style="list-style-type: none"> <li>Maintain clinic and expand hours per volume</li> <li>Maintain scholarships for low income patients</li> </ul>	<p># of patients seen: 2019: 277 2020: 216 2021: 284</p> <p>Scholarships (awarded for 12 visits, extended if patient makes recommended lifestyle changes to enhance their health): 2019: 2 scholarships + extension 2020: 3 scholarships + 4 extensions 2021: 6 scholarships + 1 extension</p>	
Offer Health Institute Educational Programs	<ul style="list-style-type: none"> <li>Cardiac Connect – phase III cardiac rehab.</li> <li>Heart Month Lecture Series</li> <li>Diabetes Awareness Month Lecture Series</li> <li>Increase health literacy through educational seminars on various</li> </ul>	<p>2019:</p> <ul style="list-style-type: none"> <li>\$10/mnth, avg. 15 participants per class, 2X weekly.</li> <li>Collaboration with Cardiology physicians for X3 lectures in February.</li> <li>Collaboration with Endocrinology for X3 lectures on Diabetes in November.</li> </ul>	Cardiology, Endocrinology

QUAD-COUNTY REGIONAL COMMUNITY HEALTH NEEDS ASSESSMENT

Carson Tahoe Health Progress on 2019 CHNA Priorities			
	health related topics.	2020 - On hold due to COVID-19 restrictions  2021: <ul style="list-style-type: none"> <li>• \$10/mnth, avg. 15 participants per class, 2X weekly.</li> <li>• Collaboration with Cardiology physicians for X3 lectures in February.</li> <li>• Collaboration with Endocrinology for 3X diabetes lectures.</li> <li>• Collaboration with Clinical Nutrition for 1X nutrition demonstration and educational seminar.</li> </ul>	
Develop Neurosurgery	<ul style="list-style-type: none"> <li>• Add Neurosurgeon</li> <li>• Offer cranial procedures</li> </ul>	<ul style="list-style-type: none"> <li>• Evaluation of 106 new patients in 2021</li> </ul>	
Continue Patient Support Groups	<ul style="list-style-type: none"> <li>• Maintain monthly no-cost stroke support group</li> </ul>	# of Participants: 2019: 144 2020: 0 2021: 60	Carson Tahoe Physical Therapy
Expand Telehealth Options	<ul style="list-style-type: none"> <li>• Maintain telestroke program</li> </ul>	Agreement renewed with the University of Utah for telestroke program	University of Utah
Nutrition, Physical Activity & Weight			
Strategy	Action	Measurement/Additional Information	Partner
Offer Educational Programs through	Collaborate with Clinical Nutrition to provide educational	2019 <ul style="list-style-type: none"> <li>• 2 X nutrition seminar and food</li> </ul>	

QUAD-COUNTY REGIONAL COMMUNITY HEALTH NEEDS ASSESSMENT

Carson Tahoe Health Progress on 2019 CHNA Priorities			
Center for Health Promotion	seminars and cooking demonstrations.	demonstration – November & February. 2020 • No classes due to COVID-19 2021 • 3X virtual/video food demonstrations – February, March and November.	
Support Physical Therapist for Carson High School	<ul style="list-style-type: none"> <li>Dedicated Physical Therapist for Carson High School athletic program</li> </ul>	\$304,934 over the course of 2019, 2020, and 2021	Carson High School
Invest in the expansion of community health & nutrition resources	<ul style="list-style-type: none"> <li>Financially support local organizations expanding services</li> </ul>	\$137,165 donated from Community Partnership Fund in support of nutrition and healthy food access	The Greenhouse Project
Cancer			
Strategy	Action	Measurement/Additional Information	Partner
Expand local access to Oncology care	Recruit Oncologist to service area	<ul style="list-style-type: none"> <li>Dolor, Gladys APRN Nurse Practitioner</li> </ul>	Carson Tahoe Medical Group
Skin Cancer Screening Program	Continued collaboration with Carson Tahoe Cancer Center for increased education on prevention of skin cancer and FREE screenings.	2019: 4 days, 128 skin cancer screenings provided. Educational materials provided to all participants. 2020: due to COVID-19 restrictions, screening volumes were decreased to comply with social distancing guidelines. 2 days, 66 screenings provided. Educational	

QUAD-COUNTY REGIONAL COMMUNITY HEALTH NEEDS ASSESSMENT

Carson Tahoe Health Progress on 2019 CHNA Priorities			
		material provided to all participants. 2021:2 days, 78 screenings provided. Educational material provided to all participants.	
Colorectal Cancer Screenings	In collaboration with Carson Tahoe Cancer Center, provide FREE colorectal cancer screenings and education on prevention and early intervention.	2021: 100 FOBT colorectal cancer screening kits were given. Educational event in conjunction with Nevada Cancer Coalition and included Colin the Colon. Educational materials were provided.	
Continue Tobacco Cessation Classes	<ul style="list-style-type: none"> <li>• Maintain current classes</li> <li>• Make referrals to 1-800-QUIT-NOW</li> <li>• Refer patients who smoke who have a heart attack to smoking cessation classes (98.3% referred in 2021)</li> </ul>	Participation in full session of smoking cessation class (7 weeks): 2019: 33 2020: 15 2021: 13 Team is working to build up participation after participation waned during COVID-19 peak.	CTMG Cardiology
Ensure sustainable funding for Cancer Center Patient Support Programs	Continue signature event, HopeFest, in support of patients facing cancer	HopeFest funds raised for patient support programs: 2019: \$212,378.14 2020: \$102,233.63 2021: \$92,674.06	
Continue University of Utah Healthcare/ Huntsman Cancer Institute Affiliation		Continued U of U healthcare and Huntsman Cancer Institute Affiliation;	

**QUAD-COUNTY REGIONAL COMMUNITY HEALTH NEEDS ASSESSMENT**

Carson Tahoe Health Progress on 2019 CHNA Priorities			
		Accredited by American College of Surgeon’s Commission on Cancer	
<p><b>COVID-19 Response</b> – Carson Tahoe Health activated to support our communities through COVID-19 with rapid and strategic planning to secure critical supplies and Personal Protective Equipment (PPE); testing and telehealth capabilities within 48 hours in March of 2020, which included drive-through testing at Carson Tahoe Medical Group; a COVID-19 isolation tent outside the Emergency Room of the Regional Medical Center; and, vaccination distribution abilities starting in December of 2020.</p>			
Strategy	Action	Measurement/Additional Information	Partnerships
Reduce community spread of COVID-19	COVID-19 Tests	2020: 10,397 2021: 17,983	
Support community health and resilience through vaccination	COVID-19 Vaccinations	2021: 7112	



## Appendix C: Secondary Population Data Sources

As previously cited in this report, the primary sources of secondary population data were gathered primarily from the United States Census Bureau 2016-2020 American Community Survey (ACS) Five-Year Estimates, the Nevada Rural and Frontier Health Data Book, 2021 (10<sup>th</sup> Edition), and the University of Nevada, Reno School of Medicine's Office of Statewide Initiatives Nevada Instant Atlas.

Secondary data was also gathered from the Centers for Disease Control & Prevention, National Center for Chronic Disease Prevention and Health Promotion, State of Nevada Department of Health & Human Services Office of Analytics, among many others. **Below is a comprehensive list of sources utilized throughout this CHNA.**

---

AllTrails, <https://www.alltrails.com/>

Centers for Disease Control & Prevention (CDC) WONDER Online Query System, <https://wonder.cdc.gov/>

Centers for Disease Control & Prevention. Morbidity and Mortality Weekly Report Abortion Surveillance (2019), <https://www.cdc.gov/mmwr/volumes/70/ss/ss7009a1.htm>

Centers for Disease Control and Prevention, National Center for Injury Prevention and Control. Fatal Injury Prevention & Violence Data, <https://www.cdc.gov/injury/wisqars/fatal.html>

County Health Rankings & Roadmaps, <https://www.countyhealthrankings.org/app/nevada/2022/overview>

Feeding America, Map the Meal Gap, <https://map.feedingamerica.org/>

Harvard Joint Center for Housing Studies, America's Rental Housing 2022 Report, <https://www.jchs.harvard.edu/americas-rental-housing-2022>

Kaiser Family Foundation estimates based on the Census Bureau's March Current Population Survey (CPS: Annual Social & Economic Supplements), 2017-2021

National Center for Chronic Disease Prevention and Health Promotion, Division of Population Health. Behavioral Risk Factor Surveillance System Web Enabled Analysis Tool, <https://nccd.cdc.gov/weat/>

National Center for Chronic Disease Prevention and Health Promotion, Division of Population Health. Behavioral Risk Factor Surveillance System (2019), <https://www.cdc.gov/brfss/index.html>

"National Center for Health Statistics, 2016-2020 Mortality Files"

## QUAD-COUNTY REGIONAL COMMUNITY HEALTH NEEDS ASSESSMENT

National Center for HIV, Viral Hepatitis, STD, and TB Prevention. Division of Adolescent & School Health

National Low Income Housing Coalition. Nevada Factsheet 2022 Out of Reach

National Registry of Emergency Medical Technicians

Nevada Crime Statistics. Domestic & Elderly Crimes

State of Nevada Department of Agriculture, National School Lunch Program. Free & Reduced Lunch 2021 Report

State of Nevada Department of Health & Human Services Office of Analytics. 2021 Nevada Health Profiles

State of Nevada, Division of Public and Behavioral Health and the University of Nevada, Reno. 2019 Nevada High School & Middle School Youth Risk Behavior Survey Report, <https://www.unr.edu/public-health/research-activities/nevada-youth-risk-behavior-survey>

State of Nevada Division of Environmental Protection, Lead Testing Program, <https://ndep.nv.gov/lead>

The Trevor Project National Survey on LGBTQ Youth Mental Health 2021, <https://www.thetrevorproject.org/survey-2021/?section=Introduction>

Nevada Resiliency Fund: Opioid Needs Assessment, (2022), [https://dhhs.nv.gov/uploadedFiles/dhhsnv.gov/content/Programs/Grants/Advisory\\_Committees/ACRN/081722NeedsAssessment2022.pdf](https://dhhs.nv.gov/uploadedFiles/dhhsnv.gov/content/Programs/Grants/Advisory_Committees/ACRN/081722NeedsAssessment2022.pdf)

Office of Nevada Secretary of State Barbara K. Cegavske, Voter Registration Statistics. Active Voters by County and Party (2021 & 2022), <https://www.nvsos.gov/sos/elections/voters/voter-registration-statistics/2022>

PolicyMap (Hospitals). Health Resources & Services Administration (2022)

PolicyMap (Drug and Alcohol Treatment Facilities). Substance Abuse and Mental Health Services Administration (2019)

PolicyMap (Park Locations). Trust for Public Land: ParkServe (2020)

PolicyMap. U.S. Census Bureau, 2016-2020 American Community Survey Five-Year Estimates, <https://www.policymap.com/>

Rural Nevada Continuum of Care 2021 Point-in-Time Count, [https://socialent.com/2021/06/rural-nevada-2021-point-in-time-count/?doing\\_wp\\_cron=1664405540.4957499504089355468750](https://socialent.com/2021/06/rural-nevada-2021-point-in-time-count/?doing_wp_cron=1664405540.4957499504089355468750)

## QUAD-COUNTY REGIONAL COMMUNITY HEALTH NEEDS ASSESSMENT

State of Nevada Department of Education, Nevada Accountability Portal,  
<http://nevadareportcard.nv.gov/di/>

State of Nevada Department of Health & Human Services, Office of Analytics,  
[https://dhhs.nv.gov/Programs/Office\\_of\\_Analytics/DHHS\\_Office\\_of\\_Analytics/](https://dhhs.nv.gov/Programs/Office_of_Analytics/DHHS_Office_of_Analytics/)

Substance Abuse and Mental Health Services Administration, Risk & Protective Factors,  
<https://www.samhsa.gov/sites/default/files/20190718-samhsa-risk-protective-factors.pdf>

SummitPost, Mt. Davidson, <https://www.summitpost.org/mount-davidson-nv/153745>

UDS Mapper(Veteran’s Health Administration Facilities) Health Resources & Services  
Administration Data Warehouse (2022),  
[https://maps.udsmapper.org/map?map\\_id=BE0LVnZDQM0dRYz5eX3a](https://maps.udsmapper.org/map?map_id=BE0LVnZDQM0dRYz5eX3a)

United States Bureau Of Labor Statistics. Employer-Reported Workplace Injuries & Illnesses in  
Nevada (2020), [https://www.bls.gov/regions/west/news-  
release/workplaceinjuriesandillnesses\\_nevada.htm](https://www.bls.gov/regions/west/news-release/workplaceinjuriesandillnesses_nevada.htm)

United States Census Bureau 2016-2020 American Community Survey (ACS) Five-Year  
Estimates, <https://www.census.gov/programs-surveys/acs>

United States Census Bureau, Small Area Income & Poverty Estimates,  
<https://www.census.gov/programs-surveys/saipe.html>

United States Census Bureau. Racial & Ethnic Diversity in the United States: 2010 Census &  
2020 Census, [https://www.census.gov/library/visualizations/interactive/racial-and-ethnic-  
diversity-in-the-united-states-2010-and-2020-census.html](https://www.census.gov/library/visualizations/interactive/racial-and-ethnic-diversity-in-the-united-states-2010-and-2020-census.html)

United States Department of Agriculture Food Environment Atlas,  
<https://www.ers.usda.gov/data-products/food-access-research-atlas/go-to-the-atlas/>

United States Department of Health & Human Services, Head Start Center Locator,  
<https://eclkc.ohs.acf.hhs.gov/center-locator>

United States Department of Housing and Urban Development, Program Parameters &  
Research Division,  
[https://www.huduser.gov/portal/datasets/fmr/fmrs/FY2021\\_code/2021summary.odn](https://www.huduser.gov/portal/datasets/fmr/fmrs/FY2021_code/2021summary.odn)

United States Department of Transportation. National Highway Traffic Safety Administration.  
2016-2020 Fatality Analysis Reporting

United States Environmental Protection Agency. USEPA Air Quality Analysis Maps, Nevada  
Tribal Lands, [https://www3.epa.gov/region9/air/maps/nv\\_tribe.html](https://www3.epa.gov/region9/air/maps/nv_tribe.html)

University of Nevada, Reno School of Medicine’s Office of Statewide Initiatives, Nevada Instant  
Atlas. Centers for Medicare & Medicaid Services Office of Minority Health Mapping Medicare

## QUAD-COUNTY REGIONAL COMMUNITY HEALTH NEEDS ASSESSMENT

Disparities Tool (2020), <https://data.cms.gov/tools/mapping-medicare-disparities-by-population>

University of Nevada, Reno School of Medicine's Office of Statewide Initiatives, Nevada Instant Atlas. 2021 Nevada Rural & Frontier Health Data Book, <https://med.unr.edu/statewide/reports-and-publications/nevada-rural-and-frontier-health-data-book>

University of Nevada, Reno School of Medicine's Office of Statewide Initiatives, Nevada Instant Atlas. Health Resources and Services Administration. Find shortage Areas: HPSA by State and County, <https://data.hrsa.gov/tools/shortage-area/hpsa-find>

### **University of Nevada Reno School of Medicine Office of Statewide Initiatives**

**Link:** <https://med2.unr.edu/Sl/CountyData/atlas.html>

University of Nevada, Reno School of Medicine's Office of Statewide Initiatives, Nevada Instant Atlas. Bureau of Healthcare Quality & Compliance, Nevada Compare Care, Nevada Rural Hospital Partners

University of Nevada, Reno School of Medicine's Office of Statewide Initiatives, Nevada Instant Atlas. Nevada Cancer Registry

University of Nevada, Reno School of Medicine's Office of Statewide Initiatives, Nevada Instant Atlas. Nevada Department of Public Safety

University of Nevada, Reno School of Medicine's Office of Statewide Initiatives, Nevada Instant Atlas. Nevada Office of Health Statistics & Surveillance

University of Nevada, Reno School of Medicine's Office of Statewide Initiatives, Nevada Instant Atlas. Nevada State Board of Dental Examiners

University of Nevada, Reno School of Medicine's Office of Statewide Initiatives, Nevada Instant Atlas. Nevada State Board of Medical Examiners

University of Nevada, Reno School of Medicine's Office of Statewide Initiatives, Nevada Instant Atlas. Nevada State Board of Optometry

University of Nevada, Reno School of Medicine's Office of Statewide Initiatives, Nevada Instant Atlas. Nevada State Demographer's Office

University of Nevada, Reno School of Medicine's Office of Statewide Initiatives, Nevada Instant Atlas. State of Nevada Board of Examiners for Marriage and Family Therapists and Clinical Professional Counselors

## QUAD-COUNTY REGIONAL COMMUNITY HEALTH NEEDS ASSESSMENT

University of Nevada, Reno School of Medicine's Office of Statewide Initiatives, Nevada Instant Atlas. State of Nevada Board of Examiners for Marriage, Family Therapists and Clinical Professional Counselors

University of Nevada, Reno School of Medicine's Office of Statewide Initiatives, Nevada Instant Atlas. State of Nevada Board of Examiners for Social Workers

University of Nevada, Reno School of Medicine's Office of Statewide Initiatives, Nevada Instant Atlas. U.S. Department of Commerce Bureau of Economic Analysis

University of Nevada, Reno School of Medicine's Office of Statewide Initiatives, Nevada Instant Atlas. United States Department of Veterans Health Administration

University of Nevada Reno, School of Medicine Office of Statewide Initiatives. Nevada State Board for Alcohol, Drug and Gambling Counselors, 2022

University of Nevada Reno, School of Medicine Office of Statewide Initiatives. Nevada Division of Welfare and Supportive Services. Nevada Department of Health and Human Services, Supplemental Nutrition Assistance Program

University of Nevada. Reno School of Medicine Office of Statewide Initiatives. Nevada Annual Reports of Accountability, Nevada Department of Education

## Appendix D: Stakeholder Interview Guide



### Quad-County Region CHNA Stakeholder Interview Guide

#### INTRODUCTION

Good morning [or afternoon]. My name is [Interviewer Name] from Crescendo Consulting Group. We are working with a regional agencies to conduct a Quad-County regional community health needs assessment for Carson City, Douglas, Lyon, and Storey counties, with portions of Southern Washoe County.

The purpose of this conversation is to learn more about the strengths and resources in the community as well as collect your insights regarding healthcare-related needs, ways that people seek services, ongoing impacts of the COVID-19 pandemic, and to identify service gaps and ways to better meet the needs of the community. We are also very interested to hear your insights about equal access to healthcare services and challenges or advantages that some communities may experience, if any.

We will describe our discussion in a written report; however, individual names will not be used. Please consider what you say in our conversation to be anonymous.

*Do you have any questions for me before we start?*

#### ICER-BREAKER / SELF-INTRODUCTION QUESTION

Please tell me a little about yourself and ways that you like to interact with the community where you live [where appropriate, "... and the populations your organization (or you) serves."].

#### ACCESS AND AVAILABILITY OF SERVICES

1. When you think of the good things about living in this community, what are the first things that come to mind? [PROBE: things to do, parks or other outdoor recreational activities, strong sense of family, cultural diversity]
2. Generally, what are some of the challenges to living here?

## QUAD-COUNTY REGIONAL COMMUNITY HEALTH NEEDS ASSESSMENT

3. What would you say are the two or three most urgent healthcare-related needs in the (these) community/communities? [*PROBE: obesity, diabetes, depression*]

### AFFORDABILITY OF HEALTHCARE AND BASIC NEEDS

4. To what degree are community members or families struggling with finding and accessing quality healthcare? [*PROBE: are there certain types of care that are more difficult to find?*]
5. To what degree is quality primary care and/or specialty care available? For youth specifically?
6. To what degree is quality mental healthcare or treatment for substance use available? For youth specifically?
7. How are people accessing care, for example, virtual/telemedicine, face-to-face?
8. Are healthcare services equally available to everyone regardless of gender, race, age, socioeconomics? Are there any barriers in access to services based on economic, race / ethnicity, gender, or other factors? Is there an experience of your or someone you know finding a doctor or getting needs met that you would like to share?
9. To what degree do healthcare providers care for patients in a culturally sensitive manner?
10. Do people in the community struggle with accessing other basic needs besides healthcare such as accessing nutritious / healthy food, washing and hygiene, or affordable prescription medications?
11. What are some resources or services in the community that work really well? What doesn't work?
12. For women ages 16 to 44, what is access to care for expectant mothers, new mothers, and other OBGYN services? Are there any barriers in access to services?
13. What are some of the healthcare challenges that seniors may experience in your community? (Probe: hospice, end of life care, specialists, etc.).

### PUBLIC HEALTH AND PREVENTION

14. What comes to mind when I say public health? How has your or the community's perceptions of public health changed over the past 18+ months?
15. In your community, where do you access public health information? Does the community view the local health department as a trusted source of information? Why or why not?
16. What types of prevention programs are available in your community (e.g., drug and alcohol, smoking cessation, HIV/AIDS/STI, diabetes, etc.)?
17. Do you feel that there is any stigma around the local health department (e.g., a person may choose not to utilize the health department's services because "it's for poor people")?

### HEALTH EQUITY

## QUAD-COUNTY REGIONAL COMMUNITY HEALTH NEEDS ASSESSMENT

18. Health equity is an important consideration. First, what does health equity mean to you?
19. We know some people in our community struggle to get the medical care they need. What do you think we can do about this? How can we ensure doctors and medical care are available to all people?
20. What are some of the local or community-level actions that can be done to provide for community health and wellbeing more equitably?
21. Are there any 'low hanging fruit' that could be addressed quickly?

### SOCIAL DETERMINANTS OF HEALTH

22. How difficult is it to find safe and affordable housing in your community? Name some of the greatest challenges.
23. Describe the job market in the area before the pandemic and currently. [*PROBES: Generally, are "good" jobs here, and can people get them? Is it easy to find a full-time job with good pay, benefits, and retirement?*]
24. Do you feel there is good access to broadband and high-speed internet in the region? What are some of the challenges to not having good, reliable internet?
25. How would you describe access to healthful, affordable food? What are some features or services that are working well? Where are the service gaps? What communities face unique challenges?

*If transportation has not come up yet.*

26. Does everyone typically have reliable transportation to work, the grocery store, doctors, school? If not, are there services in the community that help those without a vehicle? Do you or the people you know have reliable transportation? What personal stories or stories from friends, family or neighbors do you have to share?
27. How easy is it for families to find affordable and safe childcare in the area? What are some of the challenges or barriers?

### VULNERABLE POPULATIONS

28. What groups do you think are particularly vulnerable in your community? What are some of the biggest needs for those who are more vulnerable than others? How does the community support them? [*PROBE: veterans, youth, immigrants, LGBTQ+ populations, People of Color, seniors, people living with disabilities*]

### IMPACT OF COVID-19

29. What are one or two ways that COVID-19 has impacted your community the most? [*PROBE: community well-being, social impacts, education, youth wellbeing, or the economy*]
30. Which of these do you think will be short-term effects (e.g., "After COVID is behind us, so will the effects") or long-term effects (e.g., "The impact will be long-lasting.")?



## QUAD-COUNTY REGIONAL COMMUNITY HEALTH NEEDS ASSESSMENT

31. How do you think COVID-19 will impact the way that people take care of themselves and how people interact with the healthcare system or doctors and other providers, such as for screenings or routine services, vaccine perceptions, virtual healthcare, or others?
32. How, if at all, has COVID-19 affected trust of healthcare providers or systems and the public health system?
33. From what you have seen and experienced, how has the pandemic affected mental health or substance misuse issues?

### ENHANCING OUTREACH AND DISSEMINATING INFORMATION

34. To what degree is health literacy a community advantage or challenge? Is there adequate health information available – especially in diverse or marginalized communities? How do you think health organizations can improve health literacy of the community?
35. Reference: Health literacy is: [from Healthy People 2020]: “The degree to which individuals have the capacity to obtain, process, and understand basic health information and services needed to make appropriate health decisions.”
36. When community members need help, who do they tend to turn to for assistance (healthcare-related, community services, or otherwise)? [*PROBE: friends and family, Town Hall, local Health Department, their doctor, churches*]
  - a. Basic needs, for example, food, rent, and utility assistance?
  - b. Unexpected pregnancy?
37. How do community members generally learn about access to and availability of services in the area (e.g., on-line directory; social media; hotline; word of mouth)? What method tends to work the best or worst?
38. What do you think are some challenges to spreading awareness and understanding of the availability of services and ways to access them? What might help overcome the challenges?
39. What types of activities would best reach those more vulnerable parts of community? (people experiencing homelessness, people living with disabilities, or other diverse or hard-to-reach populations)

### BEHAVIORAL HEALTH CRISIS AND SUPPORT

40. When community members need help in a mental health crisis, who do they tend to turn to for assistance (healthcare-related, community services, or otherwise)? [*PROBE: friends and family, Town Hall, local Health Department, their doctor, churches*]
41. What about in a substance use crisis? What substances do you see or hear about in the community?
42. What services are most helpful? What other services or supports would you like to see?

## QUAD-COUNTY REGIONAL COMMUNITY HEALTH NEEDS ASSESSMENT

### COMMUNITY CONNECTION AND SOCIAL SUPPORT

**Social associations can help us live healthier lives. These associations may include civic organizations, bowling centers, golf clubs, fitness centers, sports organizations, religious organizations, political organizations, labor organizations, business organizations, professional organizations, and others.**

43. To what degree is social association a community advantage or challenge?
44. Do you as a resident of your community get enough social interaction? Where do you get that interaction, and which of those are the most fulfilling sources?
45. Do you wish there were more opportunities for social interaction? If so, what would you like to see? [PROBE: how about for youth specifically?]
  - a. What barriers are there to participation in social interaction for you? For others in your community?
  - b. Are you lonely? To what extent do you feel comfortable asking for support, and where do you go?
46. To what degree is social support between community members an advantage or challenge? So, for example, acts such as helping, sharing, comforting, donating, volunteering, or cooperation, that are intended to benefit others.
  - a. Are there opportunities to support your community through helping, sharing, comforting, donating, volunteering, or other types of cooperation? If so, in where and in what ways? What barriers are there to participation in such activities?
  - b. Do you wish there were more opportunities for social support between community members? If so, what would you like to see?

### FOR PROVIDERS:

47. What is your specialty?
48. Are you burned-out or overworked?
49. Are you looking to change your practice situation (retire, sell your practice, moved to an employed model, etc.?)
50. Where do you get support as a provider?

## Appendix E: Focus Group Discussion Moderator’s Guide



### Quad-County Region CHNA

#### General Focus Group Moderators Guide

Good morning [or afternoon]. My name is [*Moderator Name*] from Crescendo Consulting Group. I am joined by my colleague, [name], who will be taking notes today. We are working with a regional agencies to conduct a Quad-County regional community health needs assessment for Carson City, Douglas, Lyon, and Storey Counties, with portions of Southern Washoe County.

#### EXPLAIN THE GENERAL PURPOSE OF THE DISCUSSION

The purpose of this conversation is to learn more about the strengths and resources in the community as well as collect your insights regarding healthcare-related needs, ways that people seek services, ongoing impacts of the COVID-19 pandemic, and to identify service gaps and ways to better meet the needs of the community. We are also very interested to hear your insights about equal access to healthcare services and challenges or advantages that some communities may experience, if any.

#### EXPLAIN THE NECESSITY FOR NOTETAKING AND RECORDING

We’re taking notes and recording the session to assist us in recalling your thoughts. We will describe our discussion in a written report; however, individual names will not be used. Please consider what you say and hear today to be confidential.

#### DESCRIBE LOGISTICS (VIRTUAL GROUPS)

Logistics are a bit different than normal since we’re virtual, but we’d appreciate it if you gave us your full attention for the next hour or so. If you need to take a break to use the restroom, please do.

- If you have a private question, feel free to type it in the chat area of the software and I’ll respond as soon as possible.

#### DESCRIBE THE PROTOCOL FOR THOSE WHO HAVE NOT BEEN TO A GROUP BEFORE

## QUAD-COUNTY REGIONAL COMMUNITY HEALTH NEEDS ASSESSMENT

For those of you who have not participated in a focus group before, the basic process is that I will ask questions throughout our session, however, please feel free to speak up at any time. In fact, I encourage you to respond directly to the comments other people make, as this is a conversation. If you don't understand a question, let me know. We are here to ask questions, listen, and make sure everyone has a chance to share and feels comfortable. Be respectful of the opinions of others. Honest opinions are the key to this process, and there are no right or wrong answers. I'd like to hear from each of you and learn more about your opinions, both positive and negative.

**Do you have any questions before we start?**

### INTRODUCTIONS

Please feel free to tell us your name and include your organization or role in the community. Please briefly share how you interact with the community and the populations your organization (or you) serves, if any.

### ACCESS AND AVAILABILITY OF SERVICES

1. When you think of the good things about living in this community, what are the first things that come to mind? *[PROBE: things to do, parks or other outdoor recreational activities, strong sense of family, cultural diversity]*
2. What would you say are the two or three most urgent healthcare-related needs in the (these) community/communities? *[PROBE: obesity, diabetes, depression]*

### AFFORDABILITY OF HEALTHCARE AND BASIC NEEDS

3. To what degree are community members or families struggling with finding and accessing quality healthcare? *[PROBE: are there certain types of care that are more difficult to find?]*
  - a. To what degree is quality primary care and/or specialty care available? For youth specifically?
  - b. To what degree is quality mental healthcare or treatment for substance use available? For youth specifically?
  - c. How are people accessing care, for example, virtual/telemedicine, face-to-face?
  - d. Are healthcare services equally available to everyone regardless of gender, race, age, sexuality, socioeconomics? Are there any barriers in access to services based on economic, race / ethnicity, gender, or other factors? Is there an

## QUAD-COUNTY REGIONAL COMMUNITY HEALTH NEEDS ASSESSMENT

experience of your or someone you know finding a doctor or getting needs met that you would like to share?

- e. To what degree do healthcare providers care for patients in a culturally sensitive manner?
4. When community members need help in a mental health crisis, who do they tend to turn to for assistance (healthcare-related, community services, or otherwise)? [*PROBE: friends and family, local Health Department, their doctor, churches*]
  - a. What about in a substance use crisis? What substances do you see or hear about in the community?
  - b. What services are most helpful? What other services or supports would you like to see?
5. Do people in the community struggle with accessing other basic needs besides healthcare such as accessing nutritious / healthy food, washing and hygiene, or affordable prescription medications?
  - a. What are some resources or services in the community that work really well? What doesn't work?
6. For women ages 16 to 44, what is access to care for expectant mothers, new mothers, and other OBGYN services? Are there any barriers in access to services?
7. What are some of the healthcare challenges that seniors may experience in your community? (Probe: hospice, end of life care, specialists, etc.).
8. Have you or anyone you know experienced a work related injury? Were they able to get the care they needed in a timely manner?

### PUBLIC HEALTH AND PREVENTION

9. What comes to mind when I say public health? How has your or the community's perceptions of public health changed over the past 18+ months?
10. In your community, where do you access public health information? Does the community view the local health department as a trusted source of information? Why or why not?
11. What types of prevention programs are available in your community (e.g., drug and alcohol, smoking cessation, HIV/AIDS/STI, diabetes, etc.)?
12. Do you feel that there is any stigma around the local health department (e.g., a person may choose not to utilize the health department's services because "it's for poor people")?

## QUAD-COUNTY REGIONAL COMMUNITY HEALTH NEEDS ASSESSMENT

### HEALTH EQUITY

13. Health equity is an important consideration. First, what does health equity mean to you?
14. We know some people in our community struggle to get the medical care they need. What do you think we can do about this? How can we ensure doctors and medical care are available to all people?

### SOCIAL DETERMINANTS OF HEALTH

15. What are some non-healthcare-related challenges or barriers people in the community might have?
  - a. How difficult is it to find safe and affordable housing in your community? Name some of the greatest challenges.
  - b. To what degree of homelessness is a concern in your community? Are there any programs that are available for those who are experiencing homelessness?
  - c. Describe the job market in the area before the pandemic and currently.  
*[PROBES: Generally, are “good” jobs here, and can people get them? Is it easy to find a full-time job with good pay, benefits, and retirement?]*
  - d. Do you feel there is good access to broadband and high-speed internet in the region? What are some of the challenges to not having good, reliable internet?
  - e. Does everyone typically have reliable transportation to work, the grocery store, doctors, school? If not, are there services in the community that help those without a vehicle? Do you or the people you know have reliable transportation? What personal stories or stories from friends, family or neighbors do you have to share?
  - f. How easy is it for families to find affordable and safe childcare in the area? What are some of the challenges or barriers?

### IMPACT OF COVID-19 (IF COVID HAS NOT BEEN MENTIONED YET)

16. How do you think COVID-19 will impact the way that people take care of themselves and how people interact with the healthcare system or doctors and other providers, such as for screenings or routine services, vaccine perceptions, virtual healthcare, or others?
17. How, if at all, has COVID-19 affected trust of healthcare providers or systems and the public health system?  
From what you have seen and experienced, how has the pandemic affected mental

## QUAD-COUNTY REGIONAL COMMUNITY HEALTH NEEDS ASSESSMENT

health or substance misuse issues?

### ENHANCING OUTREACH AND DISSEMINATING INFORMATION

18. To what degree is health literacy a community advantage or challenge? Is there adequate health information available – especially in diverse or marginalized communities? How do you think health organizations can improve health literacy of the community?

Reference: Health literacy is: [from Healthy People 2020]: “The degree to which individuals have the capacity to obtain, process, and understand basic health information and services needed to make appropriate health decisions.”

19. When community members need help, who do they tend to turn to for assistance (healthcare-related, community services, or otherwise)? [*PROBE: friends and family, Town Hall, local Health Department, their doctor, churches*]
- Basic needs, for example, food, rent, and utility assistance?
  - Unexpected pregnancy?

### COMMUNITY CONNECTION AND SOCIAL SUPPORT

20. Social associations can help us live healthier lives. These associations may include civic organizations, bowling centers, golf clubs, fitness centers, sports organizations, religious organizations, political organizations, labor organizations, business organizations, professional organizations, and others. To what degree is social association a community advantage or challenge?
- Do you as a resident of your community get enough social interaction? Where do you get that interaction, and which of those are the most fulfilling sources?
  - Do you wish there were more opportunities for social interaction? If so, what would you like to see? [*PROBE: how about for youth specifically?*]
  - What barriers are there to participation in social interaction for you? For others in your community?
  - Are you lonely? To what extent do you feel comfortable asking for support, and where do you go?
21. To what degree is social support between community members an advantage or challenge? So, for example, acts such as helping, sharing, comforting, donating, volunteering, or cooperation, that are intended to benefit others.

## QUAD-COUNTY REGIONAL COMMUNITY HEALTH NEEDS ASSESSMENT

- a. Are there opportunities to support your community through helping, sharing, comforting, donating, volunteering, or other types of cooperation? If so, in where and in what ways? What barriers are there to participation in such activities?
- b. Do you wish there were more opportunities for social support between community members? If so, what would you like to see?

### MAGIC WAND

What would a vibrant, healthy, flourishing neighborhood look like? Let's assume that money and resources weren't issues. Where would you start? What is the first thing you would do for your community?



## Appendix F: Telephone Survey Templates

Carson Tahoe Health Carson City Health & Human Services, and other regional agencies are conducting a Quad-County Regional Community Health Needs Assessment to learn more about community health and issues that need more focus and attention. This short survey is designed to learn your thoughts and ideas on these important topics. ***Your comments will be kept confidential.***

### Screening Questions

1. What county do you live in?
  - Carson City
  - Douglas County
  - Lyon County
  - Storey County
  - Washoe County - (TERMINATE)
  - Other - (TERMINATE)
2. Are you 18 years of age or older?
  - Yes
  - No - TERMINATE

### Survey Questions

3. What is your zip code?

**A "healthy" community can include a variety of things such as the availability of healthcare services (including behavioral health), social services, economic and career growth opportunities, environmental factors, lifestyle topics (such as obesity, smoking, substance abuse, and healthy living issues), and others. The next few questions ask you about your opinions on programs and resources in your community.**

4. On a scale of 1 (no more focus needed) to 5 (much more focus needed), which of the following community and health-related issues do you feel need more attention for improvement?

**No more needed (1)   2   Neutral (3)   4   Much more needed (5)   I don't know**

- Transportation services for people needing to go to doctor's appointments or the hospital

## QUAD-COUNTY REGIONAL COMMUNITY HEALTH NEEDS ASSESSMENT

- Accessible sources for affordable, nutritious food
- Affordable quality childcare
- Access to quality education for youth
- General public transportation
- Access to safe, affordable housing
- Supportive housing for individuals in need of wrap-around supportive services
- Programs to support community cohesion and inclusion, including those to combat discrimination and racism
- Access to clean, public places to play and exercise
- Healthcare services for people experiencing homelessness
- Social services (other than healthcare) for people experiencing homelessness
- Primary care services (such as a family doctor or other provider of routine care)
- Emergency care and trauma services
- Long-term care or dementia care for seniors
- Affordable healthcare services for individuals or families with low income
- Affordable prescription drugs
- Counseling services for mental health issues such as depression, anxiety, and others for adults
- Counseling services for mental health issues such as depression, anxiety, and others for adolescents/children
- Support services for children with developmental disabilities
- Drug and other substance abuse education, prevention, and treatment services
- Crisis or emergency care programs for mental health
- Coordination of patient care between the hospital and other clinics, private doctors, or other health service providers
- Programs for diabetes prevention, awareness, and care
- Programs for heart health or cardiovascular health
- Programs for obesity prevention, awareness, and care
- Programs for smoking cessation (including vaping)
- Programs to help steward and protect environmental resources
- Programs and initiatives to mitigate the health impacts of environmental changes
- Healthcare services for seniors
- Women's health services / Prenatal care / Reproductive health services

Quad-County Regional Community Health Needs Assessment partners are interested in understanding social connectedness or the feeling that you belong to a group and generally feel close to other people.

5. Do you belong to any of the following in the community?
- Church, temple, or religious group
  - Social organization (such as Lions Clubs, Masonic organizations, etc.)
  - Neighborhood association or club
  - Volunteer group
  - Recreational or sports club or team
  - School, university, technical training, or adult education
  - Professional or trade organizations
  - Youth-focused organizations or groups (such as Cub Scouts, Girl Scouts, PTA, Gay Straight Alliance etc.)

## QUAD-COUNTY REGIONAL COMMUNITY HEALTH NEEDS ASSESSMENT

Other (Please specify)

6. What are other challenges in the community that you think are important for us to know?

7. If you had a magic wand and could change one thing to make your community a better place, what would it be?

### *Profile Questions*

8. To which gender identity do you most identify?

- Female
- Male
- Transgender Female
- Transgender Male
- Gender Non-Binary
- My gender identify is not listed
- I prefer not to answer

9. Are you of Hispanic, Latino, or other Spanish origin?

- Yes
- No
- I prefer not to answer

10. What is your race? [Check all that apply]

- White or Caucasian
- Black or African American
- Asian
- Native American or Alaska Native
- Native Hawaiian or other Pacific Islander
- Another race
- I prefer not to answer

11. What is your age?

- Less than 18 years old
- 18 – 24
- 25 – 34
- 35 – 44
- 45 – 54
- 55 – 64
- 65 – 74
- More than 75 years old
- I prefer not to answer

## QUAD-COUNTY REGIONAL COMMUNITY HEALTH NEEDS ASSESSMENT

12. Which of the following ranges describes your total annual household income in the past year?

- None
- Under \$15,000
- \$15,000 – \$24,999
- \$25,000 - \$34,999
- \$35,000 – \$44,999
- \$45,000 - \$54,999
- \$55,000 - \$64,999
- \$65,000 - \$74,999
- \$75,000 - \$99,999

## Appendix G: Community Survey Templates

Carson Tahoe Health and other regional agencies are conducting a Quad-County Regional Community Health Needs Assessment for Carson City, Douglas, Lyon, and Storey Counties, with portions of Southern Washoe County.

The Community Health Needs Assessment helps the partners to learn more about community health and issues that need more focus and attention. This short survey is designed to learn your thoughts and ideas on these important topics. ***Your comments will be kept confidential.***

13. What county do you live in?

- Carson City
- Douglas County
- Lyon County
- Storey County
- Washoe County
- Other (please specify)

14. What is your zip code?

### Access to Healthcare

15. Do you have a family doctor or a place where you go for routine care?

- Yes, family doctor, family health center, or clinic
- Yes, emergency room
- Yes, Walk-in urgent care
- No
- Other (please specify)

16. In the past two years, has there been one or more occasions when you needed medical or mental healthcare but chose NOT to get it?

- Yes
- No

17. If yes, what prevented you from accessing healthcare or mental health services when you needed it? (Check all that apply)

- Lack of health insurance
- Lack of money / ability to pay
- Did not feel comfortable with available providers
- Providers did not speak my language

## QUAD-COUNTY REGIONAL COMMUNITY HEALTH NEEDS ASSESSMENT

- Providers are not culturally competent
- Concern about my immigration status
- Providers not knowledgeable about people with my sexual orientation or gender status
- Lack of transportation
- Long wait times to see a provider
- Doctor's office is too far from my house
- COVID-19-related restrictions
- I don't like the providers
- Providers are not culturally competent

### *Community Health Needs*

A "healthy" community can include a variety of things such as the availability of healthcare services (including behavioral health), social services, economic and career growth opportunities, environmental factors, lifestyle topics (such as obesity, smoking, substance abuse, and healthy living issues), and others. The next few questions ask you about your opinions on programs and resources in your community.

18. On a scale of 1 (no more focus needed) to 5 (much more focus needed), which of the following community and health-related issues do you feel need more attention for improvement?

	No more needed (1)	(2)	Neutral (3)	(4)	Much more needed (5)	I don't know
Transportation services for people needing to go to doctor's appointments or the hospital						
Accessible sources for affordable, nutritious food						
Affordable quality childcare						
Access to quality education for youth						
General public transportation						
Access to safe, affordable housing						
Supportive housing for individuals in need of wrap-around supportive services						
Programs to support community cohesion and inclusion, including						

**QUAD-COUNTY REGIONAL COMMUNITY HEALTH NEEDS ASSESSMENT**

	<b>No more needed (1)</b>	<b>(2)</b>	<b>Neutral (3)</b>	<b>(4)</b>	<b>Much more needed (5)</b>	<b>I don't know</b>
those to combat discrimination and racism						
Access to clean, public places to play and exercise						
Healthcare services for people experiencing homelessness						
Social services (other than healthcare) for people experiencing homelessness						
Access to quality education and job training						
Livable wage job opportunities						
Activities for youth (such as a public pool, roller skating rink, bowling alley)						
Primary care services (such as a family doctor or other provider of routine care)						
Emergency care and trauma services						
Long-term care or dementia care for seniors						
Affordable healthcare services for individuals or families with low income						
Affordable prescription drugs						
Services to help people learn about, and enroll in, programs that provide financial support for people needing healthcare						
Counseling services for mental health issues such as depression, anxiety, and others for adults						
Counseling services for mental health issues such as depression, anxiety, and others for adolescents/children						
Support services for children with developmental disabilities						
Support services for adults with developmental disabilities						
Drug and other substance abuse education and prevention						

**QUAD-COUNTY REGIONAL COMMUNITY HEALTH NEEDS ASSESSMENT**

	<b>No more needed (1)</b>	<b>(2)</b>	<b>Neutral (3)</b>	<b>(4)</b>	<b>Much more needed (5)</b>	<b>I don't know</b>
Drug and other substance abuse early intervention services						
Drug and other substance abuse treatment services						
Programs to help drug and other substance use disorder patients in recovery stay healthy						
Crisis or emergency care programs for mental health						
Crisis or emergency care services for medical issues						
Coordination of patient care between the hospital and other clinics, private doctors, or other health service providers						
Special care (for example, caseworkers or "navigators") for people with chronic diseases such as diabetes, cancer, asthma, and others.						
Programs for diabetes prevention, awareness, and care						
Programs for heart health or cardiovascular health						
Programs for obesity prevention, awareness, and care						
Programs for smoking cessation (including vaping)						
Programs to help steward and protect environmental resources						
Programs and initiatives to mitigate the health impacts of environmental changes						
Healthcare services for seniors						
Women's health services / Prenatal care / Reproductive health services						
Services or education to help reduce teen pregnancy						
Parenting classes for new parents						
HIV / AIDS education and screening						



**QUAD-COUNTY REGIONAL COMMUNITY HEALTH NEEDS ASSESSMENT**

	No more needed (1)	(2)	Neutral (3)	(4)	Much more needed (5)	I don't know
HIV / AIDS treatment services						
Opportunities for physical fitness						

19. Thinking about Community Health, please rate each statement below on a scale of 1 (strongly disagree) to 5 (strongly agree).

	Strongly Disagree	Disagree	Neither Agree or Disagree	Agree	Strongly Agree	I don't know
My community can work together to improve its health						
My community has the resources to improve its health						
My community works together to make positive change for health						
I know my neighbors will help me stay healthy						

**Mental Health**

**We are interested in understanding the mental and emotional wellness of individuals and the community as a whole. Reminder: Your answers will be confidential and anonymous.**

20. If you were experiencing a mental health or substance abuse challenge, would you know where to turn for help?

- Yes
- No
- I'm not sure

21. Do you or your family currently have unmet mental health or substance abuse needs?

- Yes, I have an unmet need
- Yes, an adult family member has an unmet need
- Yes, a child family member has an unmet need

**QUAD-COUNTY REGIONAL COMMUNITY HEALTH NEEDS ASSESSMENT**

- No
- I don't know
- I prefer not to answer

22. Over the course of the COVID-19 pandemic, have you or someone you know experienced any of the following mental health challenges? (Please select all that apply)

- Depression or Anxiety
- Loneliness or Isolation
- Grief
- Other (please specify)

**Challenges**

23. The past two years have been a challenge for all of us. Currently, are you having any challenges with the following?

	I struggle with this issue daily	This is a common challenge for me	I frequently struggle with this issue but generally manage fairly well	I occasionally struggle but am generally doing well in this area of my life	I'm doing well in this area of my life
Regular living activities such as getting to school or work on time, grocery shopping, or doing other common tasks					
Performing well at school or work					
Managing major life issues such as relationship challenges, relocating, new job or change of school, loss of a loved one, or major illness					
Enjoying leisure activities					
Getting along well with friends and family members					

**QUAD-COUNTY REGIONAL COMMUNITY HEALTH NEEDS ASSESSMENT**

	<b>I struggle with this issue daily</b>	<b>This is a common challenge for me</b>	<b>I frequently struggle with this issue but generally manage fairly well</b>	<b>I occasionally struggle but am generally doing well in this area of my life</b>	<b>I'm doing well in this area of my life</b>
Getting along with people at work or in the community					
Feeling lonely					
Establishing and maintaining trusted relationships					

24. What are other challenges in the community that you think are important for us to know about?

25. If you had a magic wand and could change one thing to make your community a better place, what would it be?

**Social Connectedness**

Quad-County Regional Community Health Needs Assessment partners are interested in understanding social connectedness or the feeling that you belong to a group and generally feel close to other people.

26. Do you belong to any of the following in the community?

- Church, temple, or religious group
- Social organization (such as Lions Clubs, Masonic organizations, etc.)
- Neighborhood association or club
- Volunteer group
- Recreational or sports club or team
- School, university, technical training, or adult education
- Professional or trade organizations
- Youth-focused organizations or groups (such as Cub Scouts, Girl Scouts, PTA, Gay Straight Alliance, etc.)
- Other (Please specify)

**QUAD-COUNTY REGIONAL COMMUNITY HEALTH NEEDS ASSESSMENT**

27. People sometimes look to others for companionship, assistance, or other types of support. How often is each of the following kinds of support available to you if you need it?

	<b>None of the time</b>	<b>A little of the time</b>	<b>Some of the time</b>	<b>Most of the time</b>	<b>All of the time</b>
Someone you can count on to listen to you when you need to talk					
Someone to give you information to help you understand a situation					
Someone to confide in or talk to about yourself or your problems					
Someone to turn to for suggestions about how to deal with a personal problem					
Someone to help you if you were confined to bed					
Someone to take you to the doctor if you needed it					
Someone to help with daily chores if you were sick					
Someone who hugs you					
Someone to love and make you feel wanted					
Someone to get together with for relaxation					
Someone to do something enjoyable with					

**Women’s Health**

28. Do you identify as a woman or someone with a uterus?

- Yes
- No (skip to Question #22)

29. Do you currently experience pain in your pelvis that has recurred for over six months?

- Yes
- No (skip to Question #20)

30. Do you have access to adequate community resources, medical treatment, and support for your pain?

- Yes
- No

## QUAD-COUNTY REGIONAL COMMUNITY HEALTH NEEDS ASSESSMENT

- I don't know
- Other (please specify)

31. If willing, please provide additional information. Is there an event you associate with the onset of your pain? What do you think is causing your pain? Is your pain associated with intercourse, ovulation (mid-cycle), during your period, urination, or motions such as sitting, lifting, or any other identifiable action or process?

32. Have you ever been pregnant?

- Yes
- Yes, and I'm currently pregnant
- No
- I prefer not to answer

33. In the past two years, have you had any challenges accessing any of the following associated reproductive care in your location?

- Prenatal care with a medical provider
- Postpartum care with a medical provider
- Abortion
- Birth control
- STI testing and/or treatment
- Fertility treatments
- Menopause support and education
- Sexual violence or rape support
- Other (Please specify)

### *Demographic Information: A little bit about you*

34. To which gender identity do you most identify?

- Female
- Male
- Transgender Female
- Transgender Male
- Gender Non-Binary
- My gender identity is not listed
- I prefer not to answer

35. What is your sexual orientation?

- Heterosexual
- Gay/Lesbian
- Bisexual/Pansexual
- My sexual orientation is not listed
- I prefer not to answer

## QUAD-COUNTY REGIONAL COMMUNITY HEALTH NEEDS ASSESSMENT

36. Are you of Hispanic, Latino, or other Spanish origin?

- Yes
- No
- I prefer not to answer

37. What is your race? [Check all that apply]

- White or Caucasian
- Black or African American
- Asian
- Native American or Alaska Native
- Native Hawaiian or other Pacific Islander
- Another race
- I prefer not to answer

22. Which of the following ranges best describes your total annual household income in the past year?

- None
- Under \$15,000
- \$15,000 – \$24,999
- \$25,000 - \$34,999
- \$35,000 – \$44,999
- \$45,000 - \$54,999
- \$55,000 - \$64,999
- \$65,000 - \$74,999
- \$75,000 - \$99,999
- \$100,000 and above
- Unknown
- I prefer not to answer

23. What is your age?

- Less than 18 years old
- 18 – 24
- 25 – 34
- 35 – 44
- 45 – 54
- 55 – 64
- 65 – 74
- More than 75 years old
- I prefer not to answer

## QUAD-COUNTY REGIONAL COMMUNITY HEALTH NEEDS ASSESSMENT

24. Do you have any of the following disability / ability?
- A sensory impairment (vision or hearing)
  - A learning disability (i.e., ADHD, dyslexia)
  - A mobility impairment
  - A mental health disorder
  - A long-term medical illness (i.e., epilepsy, cystic fibrosis)
  - A temporary impairment due to illness or injury (i.e., broken ankle, surgery)
  - A disability or impairment not listed
  - I do not identify with a disability or impairment
  - I prefer not to answer
25. What is the highest degree or level of school you have completed? (If you're currently enrolled in school, please indicate the highest degree you have received.)
- Less than a high school diploma
  - High school degree or equivalent (such as GED/HiSET)
  - Some college, no degree
  - Associate degree
  - Bachelor's degree
  - Master's degree
  - Professional or doctorate degree (such as MD, DDS, DVM, PhD)
  - I prefer not to answer
26. What is your profession?
27. Do you live in a single-parent household?
- Yes
  - No
28. Do you live in a multi-generation household or in a home with three or more generations living together (such as grandparents, kids, and grandkids)?
- Yes
  - No

## Appendix H: Access Audit

Access audits calls are an effective way to evaluate the communities access to healthcare services within Quad-County area – *not to profile any site*. The goal of conducting access audits is to understand practical access to healthcare and other services and barriers experienced by community members seeking care. Results provide insight to access gaps, improvement strategies, and service variations. The service sites were called on the telephone by Crescendo, seeking to schedule an appointment or to learn about other factors that potentially impact community member’s access to services.

Calls were made at different times throughout the day in mid-September 2022. Thirty-six calls were attempted across the service area, of which 24 (66.6%) resulted in the caller being connected to a staff person. Remaining calls were either not answered or sent to voicemail.

**The factors used to identify areas of opportunity during the calls included:**

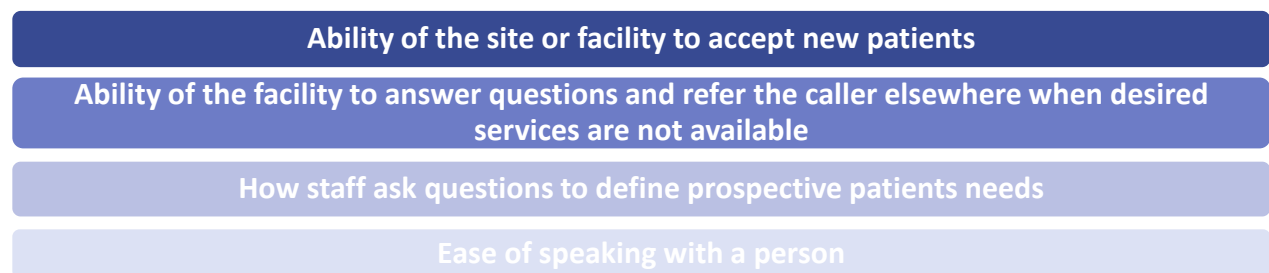

### **Ability of the site or facility to accept new patients**

Of the twenty-four sites, all but one is accepting new patients, although in several instances, not all providers were accepting new patients. Wait times for an appointment ranged depending on the facility type and/or services offered. Urgent care or crisis services, for instance, were available within hours, while primary care appointments were commonly available within one to four months, with availability often varying by provider within a practice or medical group. Staff commonly inquired as to the specific services being sought in order to provide a specific estimate of provider and/or appointment availability.

### **Ability of the facility to answer questions and refer the caller elsewhere when the desired services are unavailable**

The vast majority of sites contacted had staff members who were friendly and informative, often anticipating patient questions and providing specific information without it being explicitly requested by the caller. The staff members asked questions to assess the appropriate



## QUAD-COUNTY REGIONAL COMMUNITY HEALTH NEEDS ASSESSMENT

level of care needed and were willing to explain the process of becoming a new patient to the caller. Staff at several sites told the caller the names of providers and asked the caller if they had a preference for seeing a female or male provider. Staff at one site acknowledged that while they did not have vaccine supply to fulfill a patient request, several specific pharmacy locations in the community could likely meet the caller's needs.

### **How staff asks questions to define prospective patient's needs**

All staff members asked questions to ensure that their facilities' services aligned with the caller's needs. Staff members often proactively asked what type of insurance the caller had to make sure that the site accepts their insurance to help the caller to avoid paying out of pocket for services. Beyond insurance coverage, other probing questions intended to tailor service appropriateness included inquiries about caller (and/or child/relative) age, if the requested information was on behalf of a family member, and location (in order to determine the closest appropriate site).

### **Ease of speaking with a person**

The ease of speaking with a person varied across sites. Most sites had phone trees, and the efficiency of these automated services in connecting the caller to a person ranged from immediate to calls that were dropped or ended at voicemail boxes. Several phone trees required the caller to select an option from a list of two to nine choices without an automatic transfer to a live staff person if no choice was selected. Five of the phone trees were equipped with a choice to hear options in Spanish. The longest wait time to speak to someone was 13 minutes, but many calls were transferred to a live person immediately or within several minutes. There were two instances in which long waits (11 minutes and 22 minutes) culminated in dropped calls, with no voicemail option. All staff members answered the phone with a friendly voice and were eager to help the caller.

## QUAD-COUNTY REGIONAL COMMUNITY HEALTH NEEDS ASSESSMENT

### Healthcare Facilities

Calls were made to 36 healthcare facilities across Quad-County service area. Healthcare facilities included in the access audit calls included the following:

Healthcare Facility	
Carson Medical Group	Carson Tahoe Medical Group, Dayton
Carson Tahoe Medical Group	Rural Nevada Counseling
Sierra Nevada Health Center	Vitality
Community Counseling Center	Carson Medical Group
Carson Tahoe Behavioral Health	Job's Peak Internal Medicine and Family Practice
Carson Tahoe Walmart Clinic	Minden Family Medicine and Complete Care
Carso Tahoe Endocrinology	Carson Tahoe Physician Clinics
Eagle Valley Children's Home Respite	Carson Valley Medical Center (Hospital)
Carson Tahoe Transitional Rehabilitation Center	Mountain View Medical Group
Children's Cabinet	Douglas County Community Clinic
Rural Regional Center	THRIVE, CPLC
Banner Health Center	Sierra Family Health Center
South Lyon Medical Center (Hospital)	Community Chest
South Lyon Medical Center Physicians Clinic	Senior Services, VC & Lockwood
Community Health Nurse - Dayton	Rural Clinics, Dayton
Community Health Nurse - Fernley	Rural Clinics, Gardnerville
Community Health Nurse - Yerington	Rural Clinics, Silver Springs
Renown Medical Group - Fernley	Rural Clinics, Carson

## Appendix I: Additional Community Survey Prioritization Tables

### Prioritized Needs by CTH PSA and County

**Exhibit 220: Which of the following community and health-related issues do you feel need more attention for improvement?**

Rank	Carson City	Douglas County	Lyon County	Storey County	CTH Service Area	Total
1	Access to safe, affordable housing	Counseling services for mental health issues such as depression, anxiety, and others for adults	Access to safe, affordable housing	Access to clean, public places to play and exercise	Counseling services for mental health issues such as depression, anxiety, and others for adolescents/children	Access to safe, affordable housing
2	Counseling services for mental health issues such as depression, anxiety, and others for adults	Counseling services for mental health issues such as depression, anxiety, and others for adolescents/children	Affordable healthcare services for individuals or families with low income	Opportunities for physical fitness	Access to safe, affordable housing	Counseling services for mental health issues such as depression, anxiety, and others for adults
3	Affordable prescription drugs	Access to safe, affordable housing	Supportive housing for individuals in need of wrap-around supportive services	Services or education to help reduce teen pregnancy	Counseling services for mental health issues such as depression, anxiety, and others for adults	Counseling services for mental health issues such as depression, anxiety, and others for adolescents/children

QUAD-COUNTY REGIONAL COMMUNITY HEALTH NEEDS ASSESSMENT

Rank	Carson City	Douglas County	Lyon County	Storey County	CTH Service Area	Total
4	Affordable quality childcare	Livable wage job opportunities	Crisis or emergency care programs for mental health	Programs to help drug and other substance use disorder patients in recovery stay healthy	Affordable quality childcare	Affordable quality childcare
5	Counseling services for mental health issues such as depression, anxiety, and others for adolescents/children	Affordable quality childcare	Counseling services for mental health issues such as depression, anxiety, and others for adolescents/children	Drug and other substance abuse treatment services	Livable wage job opportunities	Affordable prescription drugs
6	Crisis or emergency care programs for mental health	Affordable prescription drugs	Drug and other substance abuse education and prevention	General public transportation	Affordable prescription drugs	Crisis or emergency care programs for mental health
7	Livable wage job opportunities	Supportive housing for individuals in need of wrap-around supportive services	Counseling services for mental health issues such as depression, anxiety, and others for adults	Programs and initiatives to mitigate the health impacts of environmental changes	Crisis or emergency care programs for mental health	Livable wage job opportunities
8	Programs to help drug and other substance use disorder patients in recovery stay healthy	Crisis or emergency care programs for mental health	Affordable quality childcare	Transportation services for people needing to go to doctor's appointments or the hospital	Affordable healthcare services for individuals or families with low income	Affordable healthcare services for individuals or families with low income

QUAD-COUNTY REGIONAL COMMUNITY HEALTH NEEDS ASSESSMENT

Rank	Carson City	Douglas County	Lyon County	Storey County	CTH Service Area	Total
9	Access to quality education for youth	Coordination of patient care between the hospital and other clinics, private doctors, or other health service providers	Affordable prescription drugs	Services to help people learn about, and enroll in, programs that provide financial support for people needing healthcare	Supportive housing for individuals in need of wrap-around supportive services	Programs to help drug and other substance use disorder patients in recovery stay healthy
10	Affordable healthcare services for individuals or families with low income	Affordable healthcare services for individuals or families with low income	Livable wage job opportunities	Activities for youth (such as a public pool, roller skating rink, bowling alley)	Programs to help drug and other substance use disorder patients in recovery stay healthy	Supportive housing for individuals in need of wrap-around supportive services
11	Social services (other than healthcare) for people experiencing homelessness	Healthcare services for seniors	Coordination of patient care between the hospital and other clinics, private doctors, or other health service providers	Affordable prescription drugs	Activities for youth (such as a public pool, roller skating rink, bowling alley)	Special care (for example, caseworkers or "navigators") for people with chronic diseases such as diabetes, cancer, asthma, and others.
12	Support services for adults with developmental disabilities	Primary care services (such as a family doctor or other provider of routine care)	Programs to help drug and other substance use disorder patients in recovery stay healthy	Coordination of patient care between the hospital and other clinics, private doctors, or other health service providers	Drug and other substance abuse treatment services	Access to quality education for youth

QUAD-COUNTY REGIONAL COMMUNITY HEALTH NEEDS ASSESSMENT

Rank	Carson City	Douglas County	Lyon County	Storey County	CTH Service Area	Total
13	Drug and other substance abuse early intervention services	Programs to help drug and other substance use disorder patients in recovery stay healthy	Drug and other substance abuse early intervention services	Counseling services for mental health issues such as depression, anxiety, and others for adolescents/children	Coordination of patient care between the hospital and other clinics, private doctors, or other health service providers	Drug and other substance abuse treatment services
14	Special care (for example, caseworkers or "navigators") for people with chronic diseases such as diabetes, cancer, asthma, and others.	Activities for youth (such as a public pool, roller skating rink, bowling alley)	General public transportation	Programs to support community cohesion and inclusion, including those to combat discrimination and racism	Drug and other substance abuse early intervention services	Coordination of patient care between the hospital and other clinics, private doctors, or other health service providers
15	Support services for children with developmental disabilities	Special care (for example, caseworkers or "navigators") for people with chronic diseases such as diabetes, cancer, asthma, and others.	Special care (for example, caseworkers or "navigators") for people with chronic diseases such as diabetes, cancer, asthma, and others.	Access to safe, affordable housing	Support services for children with developmental disabilities	Drug and other substance abuse early intervention services
16	Drug and other substance abuse treatment services	Support services for adults with developmental disabilities	Opportunities for physical fitness	Affordable quality childcare	Access to quality education for youth	Social services (other than healthcare) for people experiencing homelessness

QUAD-COUNTY REGIONAL COMMUNITY HEALTH NEEDS ASSESSMENT

Rank	Carson City	Douglas County	Lyon County	Storey County	CTH Service Area	Total
17	Access to quality education and job training	Drug and other substance abuse education and prevention	Drug and other substance abuse treatment services	Healthcare services for seniors	Support services for adults with developmental disabilities	Healthcare services for seniors
18	Healthcare services for seniors	Transportation services for people needing to go to doctor's appointments or the hospital	Primary care services (such as a family doctor or other provider of routine care)	Livable wage job opportunities	Drug and other substance abuse education and prevention	Activities for youth (such as a public pool, roller skating rink, bowling alley)
19	Long-term care or dementia care for seniors	Long-term care or dementia care for seniors	Social services (other than healthcare) for people experiencing homelessness	Accessible sources for affordable, nutritious food	Special care (for example, caseworkers or "navigators") for people with chronic diseases such as diabetes, cancer, asthma, and others.	Support services for adults with developmental disabilities
20	Supportive housing for individuals in need of wrap-around supportive services	Drug and other substance abuse treatment services	Access to quality education for youth	HIV / AIDS education and screening	Healthcare services for seniors	Support services for children with developmental disabilities
21	Accessible sources for affordable, nutritious food	Women's health services / Prenatal care / Reproductive health services	Transportation services for people needing to go to doctor's appointments or the hospital	Programs for obesity prevention, awareness, and care	Social services (other than healthcare) for people experiencing homelessness	Drug and other substance abuse education and prevention

QUAD-COUNTY REGIONAL COMMUNITY HEALTH NEEDS ASSESSMENT

Rank	Carson City	Douglas County	Lyon County	Storey County	CTH Service Area	Total
22	Activities for youth (such as a public pool, roller skating rink, bowling alley)	Parenting classes for new parents	Services or education to help reduce teen pregnancy	Access to quality education for youth	Accessible sources for affordable, nutritious food	Primary care services (such as a family doctor or other provider of routine care)
23	Coordination of patient care between the hospital and other clinics, private doctors, or other health service providers	Services or education to help reduce teen pregnancy	Services to help people learn about, and enroll in, programs that provide financial support for people needing healthcare	Social services (other than healthcare) for people experiencing homelessness	Transportation services for people needing to go to doctor's appointments or the hospital	Long-term care or dementia care for seniors
24	Health care services for people experiencing homelessness	Programs to help steward and protect environmental resources	Access to clean, public places to play and exercise	Crisis or emergency care services for medical issues	Services to help people learn about, and enroll in, programs that provide financial support for people needing healthcare	Access to quality education and job training
25	Primary care services (such as a family doctor or other provider of routine care)	Support services for children with developmental disabilities	Activities for youth (such as a public pool, roller skating rink, bowling alley)	Emergency care and trauma services	Healthcare services for people experiencing homelessness	Accessible sources for affordable, nutritious food
26	Drug and other substance abuse education and prevention	Drug and other substance abuse early intervention services	Women's health services / Prenatal care / Reproductive health services	Programs for diabetes prevention, awareness, and care	Crisis or emergency care services for medical issues	Transportation services for people needing to go to doctor's appointments or the hospital



QUAD-COUNTY REGIONAL COMMUNITY HEALTH NEEDS ASSESSMENT

Rank	Carson City	Douglas County	Lyon County	Storey County	CTH Service Area	Total
27	Services to help people learn about, and enroll in, programs that provide financial support for people needing healthcare	General public transportation	Accessible sources for affordable, nutritious food	Crisis or emergency care programs for mental health	General public transportation	Services or education to help reduce teen pregnancy
28	Crisis or emergency care services for medical issues	Crisis or emergency care services for medical issues	Access to quality education and job training	Access to quality education and job training	Primary care services (such as a family doctor or other provider of routine care)	Opportunities for physical fitness
29	Programs and initiatives to mitigate the health impacts of environmental changes	Programs for diabetes prevention, awareness, and care	Support services for children with developmental disabilities	Support services for children with developmental disabilities	Access to quality education and job training	Services to help people learn about, and enroll in, programs that provide financial support for people needing healthcare
30	Transportation services for people needing to go to doctor's appointments or the hospital	Access to quality education for youth	Crisis or emergency care services for medical issues	Counseling services for mental health issues such as depression, anxiety, and others for adults	Programs to help steward and protect environmental resources	Crisis or emergency care services for medical issues
31	Opportunities for physical fitness	Accessible sources for affordable, nutritious food	Long-term care or dementia care for seniors	Programs for smoking cessation (including vaping)	Programs for obesity prevention, awareness, and care	General public transportation

QUAD-COUNTY REGIONAL COMMUNITY HEALTH NEEDS ASSESSMENT

Rank	Carson City	Douglas County	Lyon County	Storey County	CTH Service Area	Total
32	Services or education to help reduce teen pregnancy	Healthcare services for people experiencing homelessness	Programs and initiatives to mitigate the health impacts of environmental changes	Drug and other substance abuse education and prevention	Long-term care or dementia care for seniors	Programs and initiatives to mitigate the health impacts of environmental changes
33	Programs for obesity prevention, awareness, and care	Access to quality education and job training	Emergency care and trauma services	Support services for adults with developmental disabilities	Access to clean, public places to play and exercise	Healthcare services for people experiencing homelessness
34	Programs to help steward and protect environmental resources	Services to help people learn about, and enroll in, programs that provide financial support for people needing healthcare	Healthcare services for seniors	Special care (for example, caseworkers or "navigators") for people with chronic diseases such as diabetes, cancer, asthma, and others.	Opportunities for physical fitness	Programs to help steward and protect environmental resources
35	Parenting classes for new parents	Social services (other than healthcare) for people experiencing homelessness	Programs to help steward and protect environmental resources	Primary care services (such as a family doctor or other provider of routine care)	Women's health services / Prenatal care / Reproductive health services	Women's health services / Prenatal care / Reproductive health services
36	Programs for diabetes prevention, awareness, and care	Programs to support community cohesion and inclusion, including those to combat discrimination and racism	Programs to support community cohesion and inclusion, including those to combat discrimination and racism	Affordable healthcare services for individuals or families with low income	Parenting classes for new parents	Access to clean, public places to play and exercise

QUAD-COUNTY REGIONAL COMMUNITY HEALTH NEEDS ASSESSMENT

Rank	Carson City	Douglas County	Lyon County	Storey County	CTH Service Area	Total
37	General public transportation	Opportunities for physical fitness	Programs for obesity prevention, awareness, and care	Programs to help steward and protect environmental resources	Services or education to help reduce teen pregnancy	Programs for obesity prevention, awareness, and care
38	Programs to support community cohesion and inclusion, including those to combat discrimination and racism	Programs and initiatives to mitigate the health impacts of environmental changes	Healthcare services for people experiencing homelessness	HIV / AIDS treatment services	Programs and initiatives to mitigate the health impacts of environmental changes	Programs to support community cohesion and inclusion, including those to combat discrimination and racism
39	Women's health services / Prenatal care / Reproductive health services	Access to clean, public places to play and exercise	Support services for adults with developmental disabilities	Women's health services / Prenatal care / Reproductive health services	Programs to support community cohesion and inclusion, including those to combat discrimination and racism	Parenting classes for new parents
40	Access to clean, public places to play and exercise	Programs for heart health or cardiovascular health	HIV / AIDS treatment services	Drug and other substance abuse early intervention services	Programs for diabetes prevention, awareness, and care	Programs for diabetes prevention, awareness, and care
41	HIV / AIDS treatment services	Programs for obesity prevention, awareness, and care	Parenting classes for new parents	Programs for heart health or cardiovascular health	Programs for heart health or cardiovascular health	Programs for heart health or cardiovascular health

QUAD-COUNTY REGIONAL COMMUNITY HEALTH NEEDS ASSESSMENT

Rank	Carson City	Douglas County	Lyon County	Storey County	CTH Service Area	Total
42	Programs for smoking cessation (including vaping)	Programs for smoking cessation (including vaping)	Programs for heart health or cardiovascular health	Supportive housing for individuals in need of wrap-around supportive services	Programs for smoking cessation (including vaping)	Programs for smoking cessation (including vaping)
43	Programs for heart health or cardiovascular health	HIV / AIDS education and screening	Programs for diabetes prevention, awareness, and care	Parenting classes for new parents	HIV / AIDS treatment services	Emergency care and trauma services
44	Emergency care and trauma services	Emergency care and trauma services	HIV / AIDS education and screening	Long-term care or dementia care for seniors	Emergency care and trauma services	HIV / AIDS treatment services
45	HIV / AIDS education and screening	HIV / AIDS treatment services	Programs for smoking cessation (including vaping)	Healthcare services for people experiencing homelessness	HIV / AIDS education and screening	HIV / AIDS education and screening

## Prioritized Needs by Age

Exhibit 221: Prioritized Community Needs by Age Group

Rank	Younger than 35	35 to 54	55 and older	TOTAL
1	Affordable prescription drugs	Access to safe, affordable housing	Counseling services for mental health issues such as depression, anxiety, and others for adolescents/children	Access to safe, affordable housing
2	Affordable quality childcare	Affordable quality childcare	Access to safe, affordable housing	Counseling services for mental health issues such as depression, anxiety, and others for adults
3	Counseling services for mental health issues such as depression, anxiety, and others for adults	Counseling services for mental health issues such as depression, anxiety, and others for adults	Counseling services for mental health issues such as depression, anxiety, and others for adults	Counseling services for mental health issues such as depression, anxiety, and others for adolescents/children
4	Drug and other substance abuse education and prevention	Counseling services for mental health issues such as depression, anxiety, and others for adolescents/children	Affordable prescription drugs	Affordable quality childcare
5	Access to safe, affordable housing	Crisis or emergency care programs for mental health	Crisis or emergency care programs for mental health	Affordable prescription drugs
6	Programs to help drug and other substance use disorder patients in recovery stay healthy	Livable wage job opportunities	Affordable quality childcare	Livable wage job opportunities
7	Livable wage job opportunities	Affordable healthcare services for individuals or families with low income	Supportive housing for individuals in need of wrap-around supportive services	Crisis or emergency care programs for mental health
8	Affordable healthcare services for individuals or families with low income	Access to quality education for youth	Healthcare services for seniors	Affordable healthcare services for individuals or families with low income

## QUAD-COUNTY REGIONAL COMMUNITY HEALTH NEEDS ASSESSMENT

Rank	Younger than 35	35 to 54	55 and older	TOTAL
9	Accessible sources for affordable, nutritious food	Programs to help drug and other substance use disorder patients in recovery stay healthy	Coordination of patient care between the hospital and other clinics, private doctors, or other health service providers	Supportive housing for individuals in need of wrap-around supportive services
10	Supportive housing for individuals in need of wrap-around supportive services	Special care (for example, caseworkers or "navigators") for people with chronic diseases such as diabetes, cancer, asthma, and others.	Livable wage job opportunities	Programs to help drug and other substance use disorder patients in recovery stay healthy
11	Counseling services for mental health issues such as depression, anxiety, and others for adolescents/children	Affordable prescription drugs	Affordable healthcare services for individuals or families with low income	Access to quality education for youth
12	Access to quality education for youth	Activities for youth (such as a public pool, roller skating rink, bowling alley)	Primary care services (such as a family doctor or other provider of routine care)	Social services (other than healthcare) for people experiencing homelessness
13	Transportation services for people needing to go to doctor's appointments or the hospital	Supportive housing for individuals in need of wrap-around supportive services	Social services (other than healthcare) for people experiencing homelessness	Special care (for example, caseworkers or "navigators") for people with chronic diseases such as diabetes, cancer, asthma, and others.
14	Social services (other than healthcare) for people experiencing homelessness	Coordination of patient care between the hospital and other clinics, private doctors, or other health service providers	Long-term care or dementia care for seniors	Drug and other substance abuse treatment services
15	Drug and other substance abuse early intervention services	Drug and other substance abuse early intervention services	Drug and other substance abuse treatment services	Drug and other substance abuse early intervention services

## QUAD-COUNTY REGIONAL COMMUNITY HEALTH NEEDS ASSESSMENT

Rank	Younger than 35	35 to 54	55 and older	TOTAL
16	Crisis or emergency care programs for mental health	Accessible sources for affordable, nutritious food	Programs to help drug and other substance use disorder patients in recovery stay healthy	Coordination of patient care between the hospital and other clinics, private doctors, or other health service providers
17	Support services for adults with developmental disabilities	Drug and other substance abuse treatment services	Healthcare services for people experiencing homelessness	Healthcare services for seniors
18	Activities for youth (such as a public pool, roller skating rink, bowling alley)	Services to help people learn about, and enroll in, programs that provide financial support for people needing healthcare	Special care (for example, caseworkers or "navigators") for people with chronic diseases such as diabetes, cancer, asthma, and others.	Accessible sources for affordable, nutritious food
19	Drug and other substance abuse treatment services	Access to quality education and job training	Drug and other substance abuse early intervention services	Drug and other substance abuse education and prevention
20	HIV / AIDS treatment services	Opportunities for physical fitness	Support services for children with developmental disabilities	Long-term care or dementia care for seniors
21	Opportunities for physical fitness	Services or education to help reduce teen pregnancy	Support services for adults with developmental disabilities	Activities for youth (such as a public pool, roller skating rink, bowling alley)
22	Support services for children with developmental disabilities	Social services (other than healthcare) for people experiencing homelessness	General public transportation	Support services for adults with developmental disabilities
23	Access to quality education and job training	Long-term care or dementia care for seniors	Access to quality education for youth	Primary care services (such as a family doctor or other provider of routine care)

## QUAD-COUNTY REGIONAL COMMUNITY HEALTH NEEDS ASSESSMENT

Rank	Younger than 35	35 to 54	55 and older	TOTAL
24	Programs and initiatives to mitigate the health impacts of environmental changes	Support services for adults with developmental disabilities	Drug and other substance abuse education and prevention	Access to quality education and job training
25	Services or education to help reduce teen pregnancy	Support services for children with developmental disabilities	Transportation services for people needing to go to doctor's appointments or the hospital	Support services for children with developmental disabilities
26	Special care (for example, caseworkers or "navigators") for people with chronic diseases such as diabetes, cancer, asthma, and others.	Healthcare services for seniors	Services or education to help reduce teen pregnancy	Services or education to help reduce teen pregnancy
27	Access to clean, public places to play and exercise	Drug and other substance abuse education and prevention	Services to help people learn about, and enroll in, programs that provide financial support for people needing healthcare	Transportation services for people needing to go to doctor's appointments or the hospital
28	Women's health services / Prenatal care / Reproductive health services	Crisis or emergency care services for medical issues	Access to quality education and job training	Opportunities for physical fitness
29	Parenting classes for new parents	Programs and initiatives to mitigate the health impacts of environmental changes	Crisis or emergency care services for medical issues	Services to help people learn about, and enroll in, programs that provide financial support for people needing healthcare
30	Crisis or emergency care services for medical issues	Women's health services / Prenatal care / Reproductive health services	Programs to help steward and protect environmental resources	Crisis or emergency care services for medical issues



## QUAD-COUNTY REGIONAL COMMUNITY HEALTH NEEDS ASSESSMENT

Rank	Younger than 35	35 to 54	55 and older	TOTAL
31	Primary care services (such as a family doctor or other provider of routine care)	Programs to help steward and protect environmental resources	Programs and initiatives to mitigate the health impacts of environmental changes	Programs and initiatives to mitigate the health impacts of environmental changes
32	Healthcare services for seniors	Transportation services for people needing to go to doctor's appointments or the hospital	Accessible sources for affordable, nutritious food	Healthcare services for people experiencing homelessness
33	Programs for diabetes prevention, awareness, and care	Access to clean, public places to play and exercise	Activities for youth (such as a public pool, roller skating rink, bowling alley)	General public transportation
34	Long-term care or dementia care for seniors	Primary care services (such as a family doctor or other provider of routine care)	Programs for obesity prevention, awareness, and care	Programs to help steward and protect environmental resources
35	General public transportation	General public transportation	Programs to support community cohesion and inclusion, including those to combat discrimination and racism	Women's health services / Prenatal care / Reproductive health services
36	Healthcare services for people experiencing homelessness	Programs for obesity prevention, awareness, and care	Women's health services / Prenatal care / Reproductive health services	Access to clean, public places to play and exercise
37	Emergency care and trauma services	Programs for diabetes prevention, awareness, and care	Parenting classes for new parents	Programs for obesity prevention, awareness, and care
38	Programs to help steward and protect environmental resources	Programs to support community cohesion and inclusion, including those to combat discrimination and racism	Opportunities for physical fitness	Parenting classes for new parents
39	HIV / AIDS education and screening	Healthcare services for people experiencing homelessness	Access to clean, public places to play and exercise	Programs for diabetes prevention, awareness, and care

**QUAD-COUNTY REGIONAL COMMUNITY HEALTH NEEDS ASSESSMENT**

<b>Rank</b>	<b>Younger than 35</b>	<b>35 to 54</b>	<b>55 and older</b>	<b>TOTAL</b>
<b>40</b>	Programs for obesity prevention, awareness, and care	Parenting classes for new parents	Programs for diabetes prevention, awareness, and care	Programs to support community cohesion and inclusion, including those to combat discrimination and racism
<b>41</b>	Services to help people learn about, and enroll in, programs that provide financial support for people needing healthcare	Programs for smoking cessation (including vaping)	Programs for smoking cessation (including vaping)	Programs for smoking cessation (including vaping)
<b>42</b>	Programs to support community cohesion and inclusion, including those to combat discrimination and racism	Programs for heart health or cardiovascular health	Emergency care and trauma services	Programs for heart health or cardiovascular health
<b>43</b>	Coordination of patient care between the hospital and other clinics, private doctors, or other health service providers	HIV / AIDS education and screening	Programs for heart health or cardiovascular health	Emergency care and trauma services
<b>44</b>	Programs for heart health or cardiovascular health	HIV / AIDS treatment services	HIV / AIDS treatment services	HIV / AIDS treatment services
<b>45</b>	Programs for smoking cessation (including vaping)	Emergency care and trauma services	HIV / AIDS education and screening	HIV / AIDS education and screening

### Prioritized Needs – Less than \$55,000 vs. \$55,000 or more

Respondents with household income less than \$55,000 put a slightly higher priority on issues involving affordability, such as housing, prescription drugs, quality childcare, and healthcare, than those with household income of \$55,000 or more.

**Exhibit 222: Which of the following community and health-related issues do you feel need more attention for improvement?**

Rank	Less than \$55,000	\$55,000 or more	Total
1	Access to safe, affordable housing	Counseling services for mental health issues such as depression, anxiety, and others for adolescents/children	Access to safe, affordable housing
2	Affordable prescription drugs	Counseling services for mental health issues such as depression, anxiety, and others for adults	Counseling services for mental health issues such as depression, anxiety, and others for adults
3	Affordable quality childcare	Access to safe, affordable housing	Counseling services for mental health issues such as depression, anxiety, and others for adolescents/children
4	Counseling services for mental health issues such as depression, anxiety, and others for adults	Affordable quality childcare	Affordable quality childcare
5	Affordable healthcare services for individuals or families with low income	Crisis or emergency care programs for mental health	Affordable prescription drugs
6	Livable wage job opportunities	Supportive housing for individuals in need of wrap	Crisis or emergency care programs for mental health
7	Programs to help drug and other substance use disorder patients in recovery stay healthy	Affordable prescription drugs	Livable wage job opportunities
8	Access to quality education for youth	Livable wage job opportunities	Affordable healthcare services for individuals or families with low income

## QUAD-COUNTY REGIONAL COMMUNITY HEALTH NEEDS ASSESSMENT

Rank	Less than \$55,000	\$55,000 or more	Total
9	Transportation services for people needing to go to doctor's appointments or the hospital	Affordable healthcare services for individuals or families with low income	Programs to help drug and other substance use disorder patients in recovery stay healthy
10	Services or education to help reduce teen pregnancy	Programs to help drug and other substance use disorder patients in recovery stay healthy	Supportive housing for individuals in need of wrap-around supportive services
11	Access to quality education and job training	Drug and other substance abuse treatment services	Special care (for example, caseworkers or "navigators") for people with chronic diseases such as diabetes, cancer, asthma, and others.
12	Opportunities for physical fitness	Social services (other than healthcare) for people experiencing homelessness	Access to quality education for youth
13	Accessible sources for affordable, nutritious food	Drug and other substance abuse early intervention services	Drug and other substance abuse treatment services
14	Social services (other than healthcare) for people experiencing homelessness	Drug and other substance abuse education and prevention	Coordination of patient care between the hospital and other clinics, private doctors, or other health service providers
15	Supportive housing for individuals in need of wrap	Coordination of patient care between the hospital and other clinics, private doctors, or other health service providers	Drug and other substance abuse early intervention services
16	Support services for adults with developmental disabilities	Special care (for example, caseworkers or "navigators") for people with chronic diseases such as diabetes, cancer, asthma, and others.	Social services (other than healthcare) for people experiencing homelessness
17	Programs and initiatives to mitigate the health impacts of environmental changes	Support services for children with developmental disabilities	Healthcare services for seniors
18	Activities for youth (such as a public pool, roller skating rink, bowling alley)	Activities for youth (such as a public pool, roller skating rink, bowling alley)	Activities for youth (such as a public pool, roller skating rink, bowling alley)

## QUAD-COUNTY REGIONAL COMMUNITY HEALTH NEEDS ASSESSMENT

Rank	Less than \$55,000	\$55,000 or more	Total
19	Drug and other substance abuse early intervention services	Accessible sources for affordable, nutritious food	Support services for adults with developmental disabilities
20	Long-term care or dementia care for seniors	Healthcare services for seniors	Support services for children with developmental disabilities
21	Special care (for example, caseworkers or "navigators") for people with chronic diseases such as diabetes, cancer, asthma, and others.	Access to quality education for youth	Drug and other substance abuse education and prevention
22	Counseling services for mental health issues such as depression, anxiety, and others for adolescents/children	Long-term care or dementia care for seniors	Primary care services (such as a family doctor or other provider of routine care)
23	Primary care services (such as a family doctor or other provider of routine care)	Services to help people learn about, and enroll in, programs that provide financial support for people needing healthcare	Long-term care or dementia care for seniors
24	Women's health services / Prenatal care / Reproductive health services	Support services for adults with developmental disabilities	Access to quality education and job training
25	Programs to help steward and protect environmental resources	Primary care services (such as a family doctor or other provider of routine care)	Accessible sources for affordable, nutritious food
26	Crisis or emergency care programs for mental health	Crisis or emergency care services for medical issues	Transportation services for people needing to go to doctor's appointments or the hospital
27	Healthcare services for seniors	Access to clean, public places to play and exercise	Services or education to help reduce teen pregnancy
28	Drug and other substance abuse education and prevention	Healthcare services for people experiencing homelessness	Opportunities for physical fitness
29	Drug and other substance abuse treatment services	General public transportation	Services to help people learn about, and enroll in, programs that provide financial support for people needing healthcare

## QUAD-COUNTY REGIONAL COMMUNITY HEALTH NEEDS ASSESSMENT

Rank	Less than \$55,000	\$55,000 or more	Total
30	Programs for obesity prevention, awareness, and care	Access to quality education and job training	Crisis or emergency care services for medical issues
31	Programs for diabetes prevention, awareness, and care	Services or education to help reduce teen pregnancy	General public transportation
32	Coordination of patient care between the hospital and other clinics, private doctors, or other health service providers	Parenting classes for new parents	Programs and initiatives to mitigate the health impacts of environmental changes
33	General public transportation	Programs and initiatives to mitigate the health impacts of environmental changes	Healthcare services for people experiencing homelessness
34	Crisis or emergency care services for medical issues	Transportation services for people needing to go to doctor's appointments or the hospital	Programs to help steward and protect environmental resources
35	Support services for children with developmental disabilities	Opportunities for physical fitness	Women's health services / Prenatal care / Reproductive health services
36	Programs to support community cohesion and inclusion, including those to combat discrimination and racism	Programs to help steward and protect environmental resources	Access to clean, public places to play and exercise
37	Healthcare services for people experiencing homelessness	Women's health services / Prenatal care / Reproductive health services	Programs for obesity prevention, awareness, and care
38	HIV / AIDS education and screening	Programs for obesity prevention, awareness, and care	Programs to support community cohesion and inclusion, including those to combat discrimination and racism
39	Services to help people learn about, and enroll in, programs that provide financial support for people needing healthcare	Programs to support community cohesion and inclusion, including those to combat discrimination and racism	Parenting classes for new parents

**QUAD-COUNTY REGIONAL COMMUNITY HEALTH NEEDS ASSESSMENT**

<b>Rank</b>	<b>Less than \$55,000</b>	<b>\$55,000 or more</b>	<b>Total</b>
<b>40</b>	Access to clean, public places to play and exercise	Emergency care and trauma services	Programs for diabetes prevention, awareness, and care
<b>41</b>	Parenting classes for new parents	Programs for diabetes prevention, awareness, and care	Programs for heart health or cardiovascular health
<b>42</b>	Programs for smoking cessation (including vaping)	HIV / AIDS treatment services	Programs for smoking cessation (including vaping)
<b>43</b>	Programs for heart health or cardiovascular health	Programs for smoking cessation (including vaping)	Emergency care and trauma services
<b>44</b>	HIV / AIDS treatment services	Programs for heart health or cardiovascular health	HIV / AIDS treatment services
<b>45</b>	Emergency care and trauma services	HIV / AIDS education and screening	HIV / AIDS education and screening

## Appendix J: Additional Needs Prioritization Process and Results

The Needs Prioritization Process brought together the summary of results from secondary research data, qualitative research themes, and the community and telephone survey. The summary and the process were described for the participants in an advance e-mail as follows:

**Primary and secondary research.** The needs included in the Prioritization Process were derived from the extensive secondary and primary research described below.

- **Secondary research:** Secondary research includes extensive amounts of data from the US Census Bureau; sites providing information on poverty and other social determinants of health measures; University of Nevada Reno School of Medicine’s Office of Statewide Initiatives’ Nevada Instant Atlas; and many other validated data sources.
- **Primary research:** This includes a *community and telephone survey* with approximately 1,900 responses total, results from *qualitative research* (i.e., 46 in-depth stakeholder interviews and results from 15 focus groups).

**Direct linkages between the needs and the research data.** A detailed list of 43 needs were identified for the Quad-County Region. Each of the needs in the prioritization process directly links to data observations and/or qualitative feedback. The resulting list of needs represents the items participants were asked to evaluate in the Prioritization Process.

### Exhibit 223: Community Needs Identified from the Primary and Secondary Research

Need
Increase access to affordable prescription drugs
Increase number of mental health providers for children
Increase long-term care or dementia care for seniors
Increase drug and other substance abuse treatment services
Improve transportation services for people needing to go to doctor’s appointments or the hospital, especially in rural areas
Increase the number of Spanish-speaking healthcare providers at the hospital and in the community
Increase access to specialty healthcare providers in the community (i.e., neurologists, endocrinologists)



## QUAD-COUNTY REGIONAL COMMUNITY HEALTH NEEDS ASSESSMENT

Need
Improve care coordination between the hospital and other clinics, private doctors, or other health service providers
Develop supportive/transitional housing for individuals in need of wraparound supportive services
Increase the number of primary care services (such as a family doctor or other provider of routine care)
Improve access to internet and broadband
Increase access to affordable quality childcare
Increase the number of programs to help drug and other substance use disorder patients in recovery stay healthy
Increase case management services for people with complex chronic health conditions
Increase access to affordable rental housing
Increase number of prescribing mental health providers (i.e., psychiatrists)
Improve drug and other substance abuse early intervention and prevention services
Increase number of mental health providers for adults
Increase access to developmental pediatricians or other providers who diagnose behavioral or developmental issues in children
Increase support services for children with developmental disabilities
Increase providers that understand the unique needs of the LGBTQ+ community
Develop affordable healthcare services for individuals or families with low income
Increase awareness of services or programs to help people learn about, and enroll in, programs that provide financial support for people needing healthcare
Develop crisis or emergency care programs for mental health
Develop programs to reduce social isolation, especially in seniors
Increase access to affordable housing for homeownership
Develop community programs to increase social connectivity
Improve access to healthcare services for people experiencing homelessness
Improve access to quality education for youth

## QUAD-COUNTY REGIONAL COMMUNITY HEALTH NEEDS ASSESSMENT

Need
Increase or promote opportunities for physical fitness
Increase livable wage job opportunities
Increase healthcare services for seniors
Improve crisis or emergency care services for medical issues
Improve general public transportation
Become a trauma center (Carson Tahoe Health)
Invest in activities for youth (such as a public pool, roller skating rink, bowling alley)
Increase the number of accessible sources for affordable, nutritious food
Increase programs to support community cohesion and inclusion, including those to combat discrimination and racism
Increase access to women's health services/prenatal care/reproductive health services
Develop and improve programs to help steward and protect environmental resources
Develop or increase homeless prevention programs
Provide cultural competency training to all healthcare providers and staff
Improve access to quality education and job training

As described in the Introduction, the Leadership Group utilized a modified Delphi Method to prioritize the list of needs for the region. The following table shows the rank order of needs by the Leadership Group after the first two rounds of the prioritization survey.

### Exhibit 224: Top Community Needs After Round 1 and 2 Surveys

1	Increase number of mental health providers for children
2	Increase number of mental health providers for adults
3	Increase access to affordable rental housing
4	Improve care coordination between the hospital and other clinics, private doctors, or other health service providers
5	Increase long-term care or dementia care for seniors
6	Improve drug and other substance abuse early intervention and prevention services
7	Develop crisis or emergency care programs for mental health

## QUAD-COUNTY REGIONAL COMMUNITY HEALTH NEEDS ASSESSMENT

8	Increase drug and other substance abuse treatment services
9	Improve transportation services for people needing to go to doctor's appointments or the hospital, especially in rural areas
10	Increase access to specialty healthcare providers in the community (i.e., neurologists, endocrinologists)
11	Increase number of prescribing mental health providers (i.e., psychiatrists)
12	Increase access to affordable quality childcare
13	Increase access to affordable prescription drugs
14	Increase case management services for people with complex chronic health conditions
	Increase the number of programs to help drug and other substance use disorder patients in recovery stay healthy
16	Develop supportive/transitional housing for individuals in need of wrap-around supportive services
17	Increase the number of primary care services (such as a family doctor or other provider of routine care)
18	Increase access to affordable housing for homeownership
19	Improve access to internet and broadband
20	Develop community programs to increase social connectivity
21	Increase access to developmental pediatricians or other providers who diagnose behavioral or development issues in children
22	Improve general public transportation
23	Increase the number of Spanish-speaking healthcare providers at the hospital and in the community
24	Increase programs to support community cohesion and inclusion, including those to combat discrimination and racism
	Increase healthcare services for seniors
26	Increase support services for children with developmental disabilities
27	Develop affordable healthcare services for individuals or families with low income
28	Improve access to healthcare services for people experiencing homelessness
29	Develop or increase homeless prevention programs
30	Increase providers that understand the unique needs of the LGBTQ+ community
31	Increase livable wage job opportunities
32	Develop programs to reduce social isolation, especially in seniors

## QUAD-COUNTY REGIONAL COMMUNITY HEALTH NEEDS ASSESSMENT

33	Increase access to women's health services / Prenatal care / Reproductive health services
34	Increase awareness of services or programs to help people learn about, and enroll in, programs that provide financial support for people needing healthcare
35	Invest in activities for youth (such as a public pool, roller skating rink, bowling alley)
36	Improve access to quality education and job training
37	Increase the number of accessible sources for affordable, nutritious food
38	Increase or promote opportunities for physical fitness
39	Improve access to quality education for youth
40	Provide cultural competency training to all healthcare providers and staff
41	Improve crisis or emergency care services for medical issues
42	Develop and improve programs to help steward and protect environmental resources
43	Become a trauma center (Carson Tahoe Health)

As outlined in the Introduction, the Leadership Group utilized a scoring metric that measured community partnership and feasibility, resources and capacity, and timeline. This analysis yielded the following top 20 needs.

### Exhibit 225: Top 20 Prioritized Needs after Scoring for Community Partnership & Feasibility, Resources & Capacity, and Timeline for Meaningful Progress

Top 20 Prioritized Needs
Improve drug and other substance abuse early intervention and prevention services
Improve care coordination between the hospital and other clinics, private doctors, or other health service providers
Increase access to specialty healthcare providers in the community (i.e., neurologists, endocrinologists)
Invest in activities for youth (such as a public pool, roller skating rink, bowling alley)
Increase providers that understand the unique needs of the LGBTQ+ community
Increase number of mental health providers for adults
Increase drug and other substance abuse treatment services
Increase the number of Spanish-speaking healthcare providers at the hospital and in the community

## QUAD-COUNTY REGIONAL COMMUNITY HEALTH NEEDS ASSESSMENT

Improve transportation services for people needing to go to doctor's appointments or the hospital, especially in rural areas
Increase the number of primary care services (such as a family doctor or other provider of routine care)
Increase programs to support community cohesion and inclusion, including those to combat discrimination and racism
Increase number of mental health providers for children
Increase access to affordable rental housing
Develop crisis or emergency care programs for mental health
Increase number of prescribing mental health providers (i.e., psychiatrists)
Increase case management services for people with complex chronic health conditions
Develop community programs to increase social connectivity
Develop or increase homeless prevention programs
Develop programs to reduce social isolation, especially in seniors
Increase long-term care or dementia care for seniors
Increase access to affordable quality childcare

The Leadership Group compared and discussed the rankings of each need in the community survey relative to the prioritization survey and discussed disparities across each of the counties and the CTH Primary Service Area. The individual measures were organized into broad, high-level domains of need. The resulting data was analyzed from a variety of perspectives, with each of the metrics (i.e. feasibility, resources, community perspective from survey, variance between counties, etc.) prioritized in turn to understand where there was commonality across modes of analysis.

## Appendix K: Community Resource Guide

Category	Community Resource
Access to Healthcare Services	<a href="#">A+ Hospice Care</a>
	<a href="#">Adult Day Club Respite Program</a>
	<a href="#">Advanced Healthcare of Reno</a>
	<a href="#">Advanced Home Health and Hospice</a>
	<a href="#">Alta Skilled Nursing and Rehab</a>
	<a href="#">Amy's Eden Senior Care</a>
	<a href="#">Barton Hospice</a>
	<a href="#">Care Chest of Sierra Nevada</a>
	<a href="#">Carson City Community Counseling Center</a>
	<a href="#">Carson City Health and Human Services</a>
	<a href="#">Carson City Mobile Outreach Safety Team (MOST)</a>
	<a href="#">Carson City Rural Clinics</a>
	<a href="#">Carson City School Based Health Center</a>
	<a href="#">Carson Medical Group</a>
	<a href="#">Carson Nursing and Rehab</a>
	<a href="#">Carson Tahoe Behavioral Health Services</a>
	<a href="#">Carson Tahoe Cancer Resource Services</a>
	<a href="#">Carson Tahoe Emergency Services</a>
	<a href="#">Carson Tahoe Emergent Care</a>
	<a href="#">Carson Tahoe Long Term Acute Care</a>
	<a href="#">Carson Tahoe Medical Group</a>
	<a href="#">Carson Tahoe MOM's Clinic</a>
	<a href="#">Carson Tahoe Regional Medical Center</a>
	<a href="#">Carson Tahoe Urgent Cares</a>
	<a href="#">Carson Tahoe Wal-Mart Clinics</a>
	<a href="#">Carson Valley Medical Center</a>
	<a href="#">Carson Valley Senior Living</a>
	<a href="#">Circle of Life Hospice</a>
	<a href="#">Clinical Program for Assertive Community Treatment (PACT)</a>
	<a href="#">Community Chest</a>
	<a href="#">Community Health Alliance</a>
	<a href="#">Community Health Nurses</a>
	<a href="#">Compassion Care Hospice</a>
	<a href="#">DaVita Dialysis</a>
<a href="#">Douglas County Health and Human Services</a>	
<a href="#">Dayton Rural Clinics</a>	
<a href="#">Dialysis Clinic Inc.</a>	

QUAD-COUNTY REGIONAL COMMUNITY HEALTH NEEDS ASSESSMENT

Category	Community Resource
	<a href="#">Douglas County Mobile Outreach Safety Team (MOST)</a>
	<a href="#">Douglas County Rural Clinics</a>
	<a href="#">Eden Hospice</a>
	<a href="#">Exquisite</a>
	<a href="#">Fernley Estates Assisted Living</a>
	<a href="#">FISH (Friends in Helping Service)</a>
	<a href="#">Gardnerville Health and Rehab Center</a>
	<a href="#">Green Acres Assistance Care</a>
	<a href="#">Home Health of Carson City</a>
	<a href="#">Hospice of the Valley</a>
	<a href="#">Kindred Hospice</a>
	<a href="#">Lakeside Health and Wellness</a>
	<a href="#">Liberty Dialysis</a>
	<a href="#">Life Care Center of Reno</a>
	<a href="#">Lyon County Health and Human Services</a>
	<a href="#">Lyon County Mobile Outreach Safety Team (MOST)</a>
	<a href="#">Mallory Behavioral Health Crisis Center</a>
	<a href="#">Mason Valley Residence</a>
	<a href="#">Mountain View Health and Rehab</a>
	<a href="#">Neurorestorative</a>
	<a href="#">Nevada Urban Indians</a>
	<a href="#">Northern Nevada Hopes Clinic</a>
	<a href="#">Oasis Hospice</a>
	<a href="#">Ormsby Heights Residential Care</a>
	<a href="#">Ormsby Post-Acute Rehab</a>
	<a href="#">Renown Hospice Care</a>
	<a href="#">Renown Medical Group</a>
	<a href="#">Renown Urgent Care</a>
	<a href="#">Ron Wood Family Resource Center</a>
	<a href="#">Rosewood Rehab Center</a>
	<a href="#">Rural Nevada Counseling</a>
	<a href="#">Salvation Army Clinic</a>
	<a href="#">Sierra Family Health Center</a>
	<a href="#">Sierra Nevada Health Center</a>
	<a href="#">Sierra Ridge Health and Wellness</a>
	<a href="#">Silver Springs Rural Clinics</a>
	<a href="#">Skyline Estates</a>
	<a href="#">St. Mary's Hospice</a>
	<a href="#">Storey County Health and Human Services</a>

QUAD-COUNTY REGIONAL COMMUNITY HEALTH NEEDS ASSESSMENT

Category	Community Resource
	<a href="#">Summit View Hospice</a>
	<a href="#">Tahoe Forest Hospice</a>
	<a href="#">The Chateau at Gardnerville</a>
	<a href="#">The Life Change Center of Carson City</a>
	<a href="#">The Lodge Assisted Living and Memory Care</a>
	<a href="#">THRIVE</a>
	<a href="#">United Way of Northern Nevada</a>
	<a href="#">University of Nevada, Reno Outreach Clinic</a>
	<a href="#">Virginia City Community Health Center</a>
	<a href="#">Vitality</a>
	<a href="#">Whispering Heights Guest Home</a>
	<a href="#">Wingfield Hills Health and Wellness</a>
	<a href="#">Yerington Rural Clinics</a>
	<b>Arthritis, Osteoporosis &amp; Chronic Back Conditions</b>
	<a href="#">Carson Tahoe Regional Medical Center</a>
	<a href="#">Carson Tahoe Outpatient</a>
	<a href="#">Carson Tahoe Pain Institute</a>
	<a href="#">Carson Valley Medical Center</a>
	<a href="#">Reno Orthopedic Center (ROC)</a>
	<a href="#">Tahoe Fracture and Orthopedic Medical Clinic</a>
	<b>Cancer</b>
	<a href="#">Carson Tahoe Cancer Center</a>
	<a href="#">Carson Tahoe Health Breast Center</a>
	<a href="#">Carson Tahoe Health Cancer Center Support Groups</a>
	<a href="#">Carson Tahoe Medical Group</a>
	<a href="#">Carson Tahoe Regional Medical Center</a>
	<a href="#">Carson Valley Medical Center</a>
	<a href="#">Huntsman Cancer Institute</a>
	<a href="#">Merriner Cottages, a service provided by Carson Tahoe Health</a>
	<a href="#">Renown Medical Group</a>
	<a href="#">St. Mary's Medical Group</a>
<b>Dementias Including Alzheimer's Disease</b>	<a href="#">Alzheimer Support Group</a>
	<a href="#">Carson City Senior Center</a>
	<a href="#">Carson Medical Group</a>
	<a href="#">Carson Tahoe Behavioral Health</a>
	<a href="#">Carson Tahoe Health</a>
	<a href="#">Carson Tahoe Long Term Acute Care</a>
	<a href="#">Carson Tahoe Memory Care Center</a>
	<a href="#">Carson Tahoe Medical Group</a>



QUAD-COUNTY REGIONAL COMMUNITY HEALTH NEEDS ASSESSMENT

Category	Community Resource
	<a href="#"><u>Carson Valley Medical Center</u></a>
	<a href="#"><u>Douglas County Senior Centers</u></a>
	<a href="#"><u>Lyon County Senior Centers</u></a>
	<a href="#"><u>Mallory Behavioral Health Crisis Center</u></a>
	<a href="#"><u>Nevada Department of Health and Human Services</u></a>
	<a href="#"><u>Nevada Rural Counties Retired and Senior Volunteer Program</u></a>
	<a href="#"><u>Northern Nevada Alzheimer’s Association</u></a>
	<a href="#"><u>Sanford Center for Aging</u></a>
	<a href="#"><u>Skyline Estates</u></a>
	<a href="#"><u>Storey County Senior Center</u></a>
	<a href="#"><u>The Lodge Assisted Living and Memory Care</u></a>
	<a href="#"><u>Visiting Angels</u></a>
<b>Diabetes</b>	<a href="#"><u>Care Chest of Sierra Nevada</u></a>
	<a href="#"><u>Carson City Rural Clinics</u></a>
	<a href="#"><u>Carson Medical Group</u></a>
	<a href="#"><u>Carson Tahoe Emergency Services</u></a>
	<a href="#"><u>Carson Tahoe Health Diabetes Education</u></a>
	<a href="#"><u>Carson Tahoe Health Diabetes Support Group</u></a>
	<a href="#"><u>Carson Tahoe Health Nutrition Services</u></a>
	<a href="#"><u>Carson Tahoe Health Wound Care</u></a>
	<a href="#"><u>Carson Tahoe Medical Group</u></a>
	<a href="#"><u>Carson Tahoe Regional Medical Center</u></a>
	<a href="#"><u>Carson Valley Medical Center</u></a>
	<a href="#"><u>Douglas County Rural Clinics</u></a>
	<a href="#"><u>FISH (Friends in Helping Service)</u></a>
	<a href="#"><u>Lyon County Rural Clinics</u></a>
	<a href="#"><u>Nevada Diabetes Association</u></a>
	<a href="#"><u>Renown Medical Group</u></a>
	<a href="#"><u>Storey County Rural Clinics</u></a>
	<a href="#"><u>THRIVE</u></a>
	<a href="#"><u>University of Nevada, Reno Outreach Clinic</u></a>
<b>Family Planning</b>	<a href="#"><u>Carson City Health and Human Services</u></a>
	<a href="#"><u>Carson City Rural Clinics</u></a>
	<a href="#"><u>Carson Midwifery and APRN Clinic</u></a>
	<a href="#"><u>Carson Tahoe Health Women's Health</u></a>
	<a href="#"><u>Carson Tahoe Medical Group</u></a>
	<a href="#"><u>Carson Valley Medical Center</u></a>
	<a href="#"><u>Community Health Alliance</u></a>
	<a href="#"><u>Community Health Nurses</u></a>

QUAD-COUNTY REGIONAL COMMUNITY HEALTH NEEDS ASSESSMENT

Category	Community Resource
	<a href="#"><u>Douglas County Community Health</u></a>
	<a href="#"><u>Douglas County Rural Clinics</u></a>
	<a href="#"><u>FISH (Friends in Helping Service)</u></a>
	<a href="#"><u>Life Choices Community Pregnancy Clinic</u></a>
	<a href="#"><u>Lyon County Health and Human Services</u></a>
	<a href="#"><u>Lyon County Rural Clinics</u></a>
	<a href="#"><u>Northern Nevada Hopes Clinic</u></a>
	<a href="#"><u>Planned Parenthood</u></a>
	<a href="#"><u>Ron Wood Family Resource Center</u></a>
	<a href="#"><u>Storey County Rural Clinics</u></a>
<b>Heart Disease and Stroke</b>	<a href="#"><u>Carson City Rural Clinics</u></a>
	<a href="#"><u>Carson City Senior Center</u></a>
	<a href="#"><u>Carson Medical Group</u></a>
	<a href="#"><u>Carson Tahoe Emergency Services</u></a>
	<a href="#"><u>Carson Tahoe Health Cardiology Rehab Program</u></a>
	<a href="#"><u>Carson Tahoe Health Chronic Obstructive Pulmonary Disease Clinic</u></a>
	<a href="#"><u>Carson Tahoe Health Congestive Heart Failure Clinic</u></a>
	<a href="#"><u>Carson Tahoe Health Smoking Cessation Classes</u></a>
	<a href="#"><u>Carson Tahoe Medical Group</u></a>
	<a href="#"><u>Carson Tahoe Regional Medical Center</u></a>
	<a href="#"><u>Carson Valley Medical Center</u></a>
	<a href="#"><u>Douglas County Rural Clinics</u></a>
	<a href="#"><u>Douglas County Senior Centers</u></a>
	<a href="#"><u>Heart Smart Screenings - A service of Carson Tahoe Health And Wellness</u></a>
	<a href="#"><u>Lyon County Rural Clinics</u></a>
	<a href="#"><u>Lyon County Senior Centers</u></a>
	<a href="#"><u>Renown Health Institute for Heart and Vascular Health</u></a>
	<a href="#"><u>Storey County Rural Clinics</u></a>
	<a href="#"><u>Storey County Senior Center</u></a>
<b>Immunizations and Infectious Diseases</b>	<a href="#"><u>Carson City Health and Human Services</u></a>
	<a href="#"><u>Carson City Rural Clinics</u></a>
	<a href="#"><u>Carson Medical Group</u></a>
	<a href="#"><u>Carson Tahoe Center for Health Promotion</u></a>
	<a href="#"><u>Carson Tahoe Health Wound Care</u></a>
	<a href="#"><u>Carson Tahoe Medical Group</u></a>
	<a href="#"><u>Carson Tahoe Regional Medical Center</u></a>
	<a href="#"><u>Carson Valley Medical Center</u></a>
	<a href="#"><u>Douglas County Health and Human Services</u></a>

QUAD-COUNTY REGIONAL COMMUNITY HEALTH NEEDS ASSESSMENT

Category	Community Resource
	<a href="#"><u>Douglas County Rural Clinics</u></a>
	<a href="#"><u>FISH (Friends in Helping Service)</u></a>
	<a href="#"><u>Immunize Nevada</u></a>
	<a href="#"><u>Lyon County Health and Human Services</u></a>
	<a href="#"><u>Lyon County Rural Clinics</u></a>
	<a href="#"><u>Renown Medical Group</u></a>
	<a href="#"><u>Storey County Health and Human Services</u></a>
	<a href="#"><u>Storey County Rural Clinics</u></a>
<b>Infant and Child Health</b>	<a href="#"><u>Carson City School Based Health Center</u></a>
	<a href="#"><u>Carson City School District</u></a>
	<a href="#"><u>Carson Medical Group</u></a>
	<a href="#"><u>Carson Tahoe Breastfeeding Support Group</u></a>
	<a href="#"><u>Carson Tahoe Childbirth Support Classes</u></a>
	<a href="#"><u>Carson Tahoe Medical Group</u></a>
	<a href="#"><u>Carson Tahoe MOM's Clinic</u></a>
	<a href="#"><u>Carson Tahoe Women's Health</u></a>
	<a href="#"><u>Carson Valley Medical Center</u></a>
	<a href="#"><u>Children's Cabinet</u></a>
	<a href="#"><u>Community Chest</u></a>
	<a href="#"><u>Community Food Closet</u></a>
	<a href="#"><u>Community Health Alliance</u></a>
	<a href="#"><u>Douglas County School Districts</u></a>
	<a href="#"><u>FISH (Friends in Helping Service)</u></a>
	<a href="#"><u>Life Choices Community Pregnancy Clinic</u></a>
	<a href="#"><u>Lyon County School Districts</u></a>
	<a href="#"><u>Nevada Department of Health and Human Services</u></a>
	<a href="#"><u>Northern Nevada Hopes Clinic</u></a>
	<a href="#"><u>Planned Parenthood</u></a>
	<a href="#"><u>Ron Wood Family Resource Center</u></a>
	<a href="#"><u>Storey County School Districts</u></a>
<b>Injury and Violence</b>	<a href="#"><u>Adult Protective Services</u></a>
	<a href="#"><u>Advocates to End Domestic Violence</u></a>
	<a href="#"><u>Carson City Mobile Outreach Safety Team (MOST)</u></a>
	<a href="#"><u>Carson City Sheriff's Department</u></a>
	<a href="#"><u>Carson Tahoe Emergency Services</u></a>
	<a href="#"><u>Classy Seconds</u></a>
	<a href="#"><u>Domestic Violence Resource Center</u></a>
	<a href="#"><u>Douglas County Mobile Outreach Safety Team (MOST)</u></a>
	<a href="#"><u>Douglas County Sheriff's Department</u></a>

QUAD-COUNTY REGIONAL COMMUNITY HEALTH NEEDS ASSESSMENT

Category	Community Resource
	<a href="#"><u>Exquisite</u></a>
	<a href="#"><u>Lyon County Mobile Outreach Safety Team (MOST)</u></a>
	<a href="#"><u>Lyon County Sheriff's Department</u></a>
	<a href="#"><u>Mallory Behavioral Health Crisis Center</u></a>
	<a href="#"><u>Nevada Child Protective Services</u></a>
	<a href="#"><u>Storey County Sheriff's Department</u></a>
<b>Kidney Disease</b>	<a href="#"><u>Carson Tahoe Emergency Services</u></a>
	<a href="#"><u>Carson Tahoe Medical Group</u></a>
	<a href="#"><u>Carson Tahoe Regional Medical Center</u></a>
	<a href="#"><u>Carson Valley Medical Center</u></a>
	<a href="#"><u>DaVita Dialysis</u></a>
	<a href="#"><u>Dialysis Clinic Inc.</u></a>
	<a href="#"><u>Liberty Dialysis</u></a>
<b>Mental Health</b>	<a href="#"><u>988</u></a>
	<a href="#"><u>Alcoholics Anonymous Meetings</u></a>
	<a href="#"><u>Carson City Community Counseling Center</u></a>
	<a href="#"><u>Carson City Health and Human Services</u></a>
	<a href="#"><u>Carson City Mobile Outreach Safety Team (MOST)</u></a>
	<a href="#"><u>Carson City Rural Clinics</u></a>
	<a href="#"><u>Carson City School Based Health Center</u></a>
	<a href="#"><u>Carson City School District</u></a>
	<a href="#"><u>Carson City Sheriff's Department</u></a>
	<a href="#"><u>Carson Tahoe Assertive Community Treatment Team</u></a>
	<a href="#"><u>Carson Tahoe Behavioral Health Services</u></a>
	<a href="#"><u>Carson Tahoe Detox and Rehab Program</u></a>
	<a href="#"><u>Carson Tahoe Emergency Services</u></a>
	<a href="#"><u>Carson Tahoe First Episode Psychosis Team</u></a>
	<a href="#"><u>Carson Tahoe Inpatient Services</u></a>
	<a href="#"><u>Children's Cabinet</u></a>
	<a href="#"><u>Community Chest</u></a>
	<a href="#"><u>Community Counseling Center of Carson City</u></a>
	<a href="#"><u>Community Health Alliance</u></a>
	<a href="#"><u>Douglas Health and Human Services</u></a>
	<a href="#"><u>Dayton Rural Clinics</u></a>
	<a href="#"><u>Dini-Townsend Psychiatric Hospital</u></a>
	<a href="#"><u>Douglas County Mobile Outreach Safety Team (MOST)</u></a>
	<a href="#"><u>Douglas County School Districts</u></a>
	<a href="#"><u>Douglas County Sheriff's Department</u></a>
	<a href="#"><u>Douglas County Rural Clinics</u></a>

QUAD-COUNTY REGIONAL COMMUNITY HEALTH NEEDS ASSESSMENT

Category	Community Resource
	<a href="#"><u>Eagle Valley Children's Home</u></a>
	<a href="#"><u>Fernley Rural Clinics</u></a>
	<a href="#"><u>FISH (Friends in Helping Service)</u></a>
	<a href="#"><u>Lyon County Health and Human Services</u></a>
	<a href="#"><u>Lyon County Mobile Outreach Safety Team (MOST)</u></a>
	<a href="#"><u>Lyon County School Districts</u></a>
	<a href="#"><u>Lyon County Sheriff's Department</u></a>
	<a href="#"><u>Mallory Behavioral Health Crisis Center</u></a>
	<a href="#"><u>Mallory Behavioral Health Crisis Center Warmline</u></a>
	<a href="#"><u>Narcotics Anonymous Meetings</u></a>
	<a href="#"><u>National Association for Mental Illness (NAMI)</u></a>
	<a href="#"><u>National Association for Mental Illness (NAMI) Warmline</u></a>
	<a href="#"><u>New Dawn Treatment Center</u></a>
	<a href="#"><u>New Frontier</u></a>
	<a href="#"><u>Northern Nevada Adult Mental Health Services Psychosocial Rehabilitation Program</u></a>
	<a href="#"><u>Northern Nevada Hopes Clinic</u></a>
	<a href="#"><u>Northern Nevada Mental Health Court</u></a>
	<a href="#"><u>Northern Nevada Adult Mental Health Services (NNAMHS)</u></a>
	<a href="#"><u>PFLAG Carson City Region</u></a>
	<a href="#"><u>Program of Assertive Community Treatment (PACT)</u></a>
	<a href="#"><u>Ron Wood Family Resource Center</u></a>
	<a href="#"><u>Rural Nevada Counseling</u></a>
	<a href="#"><u>Silver Springs Rural Clinics</u></a>
	<a href="#"><u>Storey County School Districts</u></a>
	<a href="#"><u>Storey County Sheriff's Department</u></a>
	<a href="#"><u>Storey County Health and Human Services</u></a>
	<a href="#"><u>Suicide Prevention Networks</u></a>
	<a href="#"><u>The Life Change Center of Carson City</u></a>
	<a href="#"><u>THRIVE</u></a>
	<a href="#"><u>Veterans Administration</u></a>
	<a href="#"><u>Vitality</u></a>
	<a href="#"><u>Yerington Rural Clinics</u></a>
<b>Nutrition, Physical Activity and Weight</b>	<a href="#"><u>Carson City Aquatic Center</u></a>
	<a href="#"><u>Carson City Community Center</u></a>
	<a href="#"><u>Carson City Health and Human Services</u></a>
	<a href="#"><u>Carson City Parks and Recreation</u></a>
	<a href="#"><u>Carson City Rural Clinics</u></a>
	<a href="#"><u>Carson City School District</u></a>

QUAD-COUNTY REGIONAL COMMUNITY HEALTH NEEDS ASSESSMENT

Category	Community Resource
	<a href="#"><u>Carson City Senior Center</u></a>
	<a href="#"><u>Carson Medical Group</u></a>
	<a href="#"><u>Carson Tahoe Center for Health Promotion</u></a>
	<a href="#"><u>Carson Tahoe Health Cardiology Rehab Program</u></a>
	<a href="#"><u>Carson Tahoe Health Diabetes Education</u></a>
	<a href="#"><u>Carson Tahoe Medical Group</u></a>
	<a href="#"><u>Carson Tahoe Regional Medical Center</u></a>
	<a href="#"><u>Carson Valley Community Food Closet</u></a>
	<a href="#"><u>Community Chest</u></a>
	<a href="#"><u>Community Health Alliance</u></a>
	<a href="#"><u>Douglas Health and Human Services</u></a>
	<a href="#"><u>Dayton Rural Clinics</u></a>
	<a href="#"><u>Douglas County Community Centers</u></a>
	<a href="#"><u>Douglas County Parks and Recreation</u></a>
	<a href="#"><u>Douglas County School Districts</u></a>
	<a href="#"><u>Douglas County Senior Centers</u></a>
	<a href="#"><u>Douglas County Rural Clinics</u></a>
	<a href="#"><u>Fernley Rural Clinics</u></a>
	<a href="#"><u>FISH (Friends in Helping Service)</u></a>
	<a href="#"><u>Food for Thought</u></a>
	<a href="#"><u>Healthy Communities Coalition</u></a>
	<a href="#"><u>Lyon County Community Centers</u></a>
	<a href="#"><u>Lyon County Health and Human Services</u></a>
	<a href="#"><u>Lyon County Parks and Recreation</u></a>
	<a href="#"><u>Lyon County School Districts</u></a>
	<a href="#"><u>Lyon County Senior Centers</u></a>
	<a href="#"><u>Meals on Wheels</u></a>
	<a href="#"><u>Northern Nevada Dream Center</u></a>
	<a href="#"><u>Produce on Wheels</u></a>
	<a href="#"><u>Ron Wood Family Resource Center</u></a>
	<a href="#"><u>Salvation Army of Carson City</u></a>
	<a href="#"><u>Silver Springs Rural Clinics</u></a>
	<a href="#"><u>Storey County Community Center</u></a>
	<a href="#"><u>Storey County Parks and Recreation</u></a>
	<a href="#"><u>Storey County School Districts</u></a>
	<a href="#"><u>Storey County Senior Center</u></a>
	<a href="#"><u>Storey County Health and Human Services</u></a>
	<a href="#"><u>THRIVE</u></a>
	<a href="#"><u>Yerington Rural Clinics</u></a>

QUAD-COUNTY REGIONAL COMMUNITY HEALTH NEEDS ASSESSMENT

Category	Community Resource
<b>Oral Health</b>	<a href="#"><u>Absolute Dental</u></a>
	<a href="#"><u>Community Health Nurses</u></a>
	<a href="#"><u>FISH (Friends in Helping Service)</u></a>
	<a href="#"><u>Northern Nevada Dental Program</u></a>
	<a href="#"><u>University of Nevada, Reno Outreach Clinic</u></a>
<b>Respiratory Disease</b>	<a href="#"><u>American Cancer Association</u></a>
	<a href="#"><u>American Lung Association</u></a>
	<a href="#"><u>Carson City Health and Human Services</u></a>
	<a href="#"><u>Carson Medical Group</u></a>
	<a href="#"><u>Carson Tahoe Emergency Services</u></a>
	<a href="#"><u>Carson Tahoe Health Cancer Center</u></a>
	<a href="#"><u>Carson Tahoe Health Chronic Obstructive Pulmonary Disease Clinic</u></a>
	<a href="#"><u>Carson Tahoe Medical Group</u></a>
	<a href="#"><u>Carson Tahoe Regional Medical Center</u></a>
	<a href="#"><u>Carson Valley Medical Center</u></a>
	<a href="#"><u>Douglas Health and Human Services</u></a>
	<a href="#"><u>Lyon County Health and Human Services</u></a>
	<a href="#"><u>Storey County Health and Human Services</u></a>
	<b>Sexually Transmitted Disease</b>
<a href="#"><u>Carson City School Based Health Center</u></a>	
<a href="#"><u>Carson City School District</u></a>	
<a href="#"><u>Carson Medical Group</u></a>	
<a href="#"><u>Carson Tahoe Emergency Services</u></a>	
<a href="#"><u>Carson Tahoe Medical Group</u></a>	
<a href="#"><u>Carson Tahoe Regional Medical Center</u></a>	
<a href="#"><u>Carson Valley Medical Center</u></a>	
<a href="#"><u>Community Chest</u></a>	
<a href="#"><u>Community Health Alliance</u></a>	
<a href="#"><u>Douglas Health and Human Services</u></a>	
<a href="#"><u>Douglas County School Districts</u></a>	
<a href="#"><u>FISH (Friends in Helping Service)</u></a>	
<a href="#"><u>Life Choices Community Pregnancy Clinic</u></a>	
<a href="#"><u>Lyon County Health and Human Services</u></a>	
<a href="#"><u>Lyon County School Districts</u></a>	
<a href="#"><u>Northern Nevada Hopes Clinic</u></a>	
<a href="#"><u>Planned Parenthood</u></a>	
<a href="#"><u>Ron Wood Family Resource Center</u></a>	
<a href="#"><u>Storey County School Districts</u></a>	
<a href="#"><u>Storey County Health and Human Services</u></a>	

QUAD-COUNTY REGIONAL COMMUNITY HEALTH NEEDS ASSESSMENT

Category	Community Resource
<b>Substance Abuse</b>	<a href="#"><u>Alcoholics Anonymous Meetings</u></a>
	<a href="#"><u>Carson City Circles</u></a>
	<a href="#"><u>Carson City Community Counseling Center</u></a>
	<a href="#"><u>Carson City Health and Human Services</u></a>
	<a href="#"><u>Carson City Mobile Outreach Safety Team (MOST)</u></a>
	<a href="#"><u>Carson City Rural Clinics</u></a>
	<a href="#"><u>Carson City School Based Health Center</u></a>
	<a href="#"><u>Carson City School District</u></a>
	<a href="#"><u>Carson City Sheriff's Department</u></a>
	<a href="#"><u>Carson Tahoe Behavioral Health Services</u></a>
	<a href="#"><u>Carson Tahoe Detox and Rehab Program</u></a>
	<a href="#"><u>Carson Tahoe Emergency Services</u></a>
	<a href="#"><u>Carson Tahoe Inpatient Services</u></a>
	<a href="#"><u>Carson Tahoe Medical Group</u></a>
	<a href="#"><u>Community Chest</u></a>
	<a href="#"><u>Community Counseling Center of Carson City</u></a>
	<a href="#"><u>Community Health Alliance</u></a>
	<a href="#"><u>Douglas Health and Human Services</u></a>
	<a href="#"><u>Dayton Rural Clinics</u></a>
	<a href="#"><u>Dini-Townsend Psychiatric Hospital</u></a>
	<a href="#"><u>Douglas County Mobile Outreach Safety Team (MOST)</u></a>
	<a href="#"><u>Douglas County School Districts</u></a>
	<a href="#"><u>Douglas County Sheriff's Department</u></a>
	<a href="#"><u>Douglas County Rural Clinics</u></a>
	<a href="#"><u>Fernley Rural Clinics</u></a>
	<a href="#"><u>FISH (Friends in Helping Service)</u></a>
	<a href="#"><u>JOIN Nevada</u></a>
	<a href="#"><u>Lyon County Health and Human Services</u></a>
	<a href="#"><u>Lyon County Mobile Outreach Safety Team (MOST)</u></a>
	<a href="#"><u>Lyon County School Districts</u></a>
	<a href="#"><u>Lyon County Sheriff's Department</u></a>
	<a href="#"><u>Mallory Behavioral Health Crisis Center</u></a>
<a href="#"><u>Mallory Behavioral Health Crisis Center Warmline</u></a>	
<a href="#"><u>Narcotics Anonymous Meetings</u></a>	
<a href="#"><u>National Association for Mental Illness (NAMI)</u></a>	
<a href="#"><u>National Association for Mental Illness (NAMI) Warmline</u></a>	
<a href="#"><u>New Dawn Treatment Center</u></a>	
<a href="#"><u>New Frontier</u></a>	



QUAD-COUNTY REGIONAL COMMUNITY HEALTH NEEDS ASSESSMENT

Category	Community Resource
	<a href="#"><u>Northern Nevada Hopes Clinic</u></a>
	<a href="#"><u>Northern Nevada Adult Mental Health Services (NNAMHS)</u></a>
	<a href="#"><u>Partnership Carson City</u></a>
	<a href="#"><u>Partnership Douglas County</u></a>
	<a href="#"><u>Ron Wood Family Resource Center</u></a>
	<a href="#"><u>Rural Nevada Counseling</u></a>
	<a href="#"><u>Silver Springs Rural Clinics</u></a>
	<a href="#"><u>Storey County School Districts</u></a>
	<a href="#"><u>Storey County Sheriff's Department</u></a>
	<a href="#"><u>Storey County Health and Human Services</u></a>
	<a href="#"><u>Suicide Prevention Networks</u></a>
	<a href="#"><u>The Life Change Center of Carson City</u></a>
	<a href="#"><u>THRIVE</u></a>
	<a href="#"><u>Veterans Administration</u></a>
	<a href="#"><u>Vitality</u></a>
<b>Tobacco Use</b>	<a href="#"><u>American Heart Association</u></a>
	<a href="#"><u>Carson City Community Counseling Center</u></a>
	<a href="#"><u>Carson City Health and Human Services</u></a>
	<a href="#"><u>Carson City Rural Clinics</u></a>
	<a href="#"><u>Carson Medical Group</u></a>
	<a href="#"><u>Carson Tahoe Center for Health Promotion</u></a>
	<a href="#"><u>Carson Tahoe Health Smoking Cessation Classes</u></a>
	<a href="#"><u>Carson Valley Medical Center</u></a>
	<a href="#"><u>Douglas Health and Human Services</u></a>
	<a href="#"><u>Dayton Rural Clinics</u></a>
	<a href="#"><u>Douglas County Rural Clinics</u></a>
	<a href="#"><u>Fernley Rural Clinics</u></a>
	<a href="#"><u>Lyon County Health and Human Services</u></a>
	<a href="#"><u>Quitline</u></a>
	<a href="#"><u>Silver Springs Rural Clinics</u></a>
<a href="#"><u>Storey County Health and Human Services</u></a>	
<a href="#"><u>Yerington Rural Clinics</u></a>	
<b>Vision and Hearing</b>	<a href="#"><u>Carson City Health and Human Services</u></a>
	<a href="#"><u>Costco Hearing Aid Center</u></a>
	<a href="#"><u>Douglas County Health and Human Services</u></a>
	<a href="#"><u>Douglas County School Districts</u></a>
	<a href="#"><u>Lions Club</u></a>

QUAD-COUNTY REGIONAL COMMUNITY HEALTH NEEDS ASSESSMENT

Category	Community Resource
	<a href="#">Lyon County Health and Human Services</a>
	<a href="#">Lyon County School Districts</a>
	<a href="#">Sanford Center for Aging</a>
	<a href="#">Storey County School Districts</a>
	<a href="#">Storey County Health and Human Services</a>